

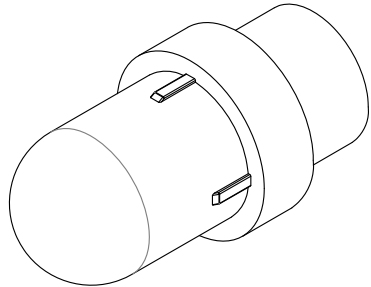

Part No.	X = Body Length
PLP1-100-S	0.100 (2.5mm)
PLP1-125-S	0.125 (3.2mm)
PLP1-2.5MM-S	2.5mm (0.100")
PLP1-3MM-S	3mm (0.118")

REV.	DESCRIPTION	DATE	APPROVED
A	Engineering Release	07/15/15	J. C.

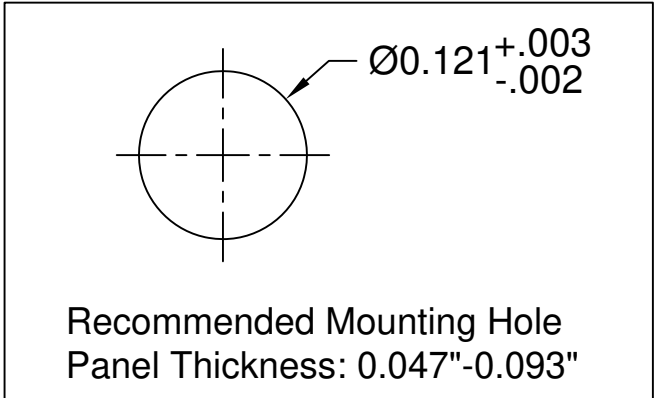
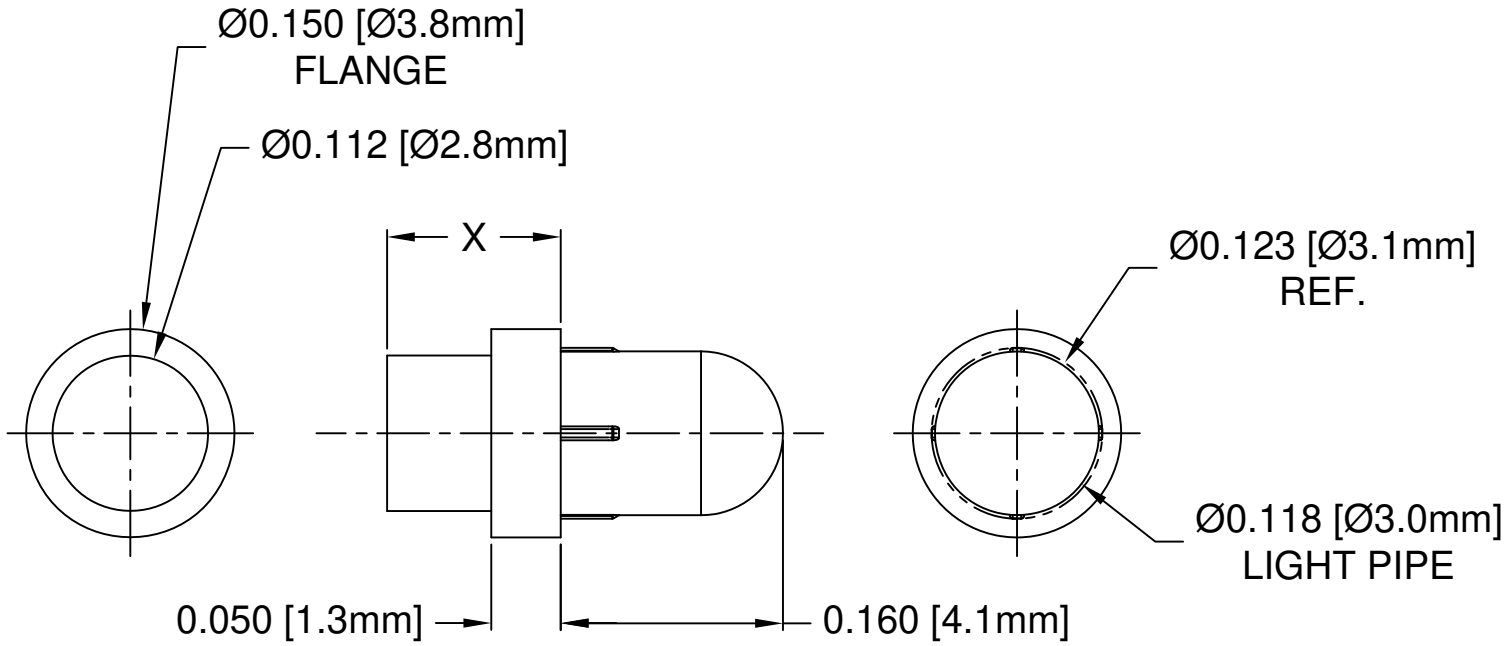

- 2. MATERIAL: POLYCARBONATE, 94V-0, BLACK DIFFUSED.
- 1. GENERAL SPECIFICATIONS: BIVAR MOLDED COMPONENT SPECIFICATION BV00-E101 and BSMC-1001.

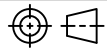
STANDARD TOLERANCE (UNLESS OTHERWISE SPECIFIED)		 4 THOMAS, IRVINE, CA. 92618 TEL: (949) 951-8808 FAX: (949) 951-3974	
DECIMALS	ANGULAR		
.X ± .1	X° ± 1°		TITLE: PRESS-FIT, PANEL MOUNT, LIGHT PIPE, ROUND TOP, SMOKED PART NO: PLP1-XXX-S REVISION: A
.XX ± .01			
.XXX ± .005			
DESIGNED: Brian Oliver	DATE: 04/02/15	DESIGNED: Brian Oliver	DATE: 04/02/15
CHECKED: A. Wright	DATE: 04/02/15	CAGE CODE : 32559	SHEET # 1 OF 1
CAD GENERATED DOCUMENT. DO NOT MEASURE DRAWING.			