

SN55HVD233-SP 3.3-V Radiation Hardened CAN Transceiver

1 Features

- QMLV (QML Class V) Radiation Hardness Assured (RHA) MIL-PRF 38535 Qualified, SMD 5962L1420901VXC
 - Single Event Latch-up (SEL) Immune to 86 MeV-cm²/mg at 125°C
 - Total Ionizing Dose (TID) immune up to 50 kRad (Si) at Low Dose Rate
 - Qualified over the Military Temperature Range (–55°C to 125°C)
 - High-Performance 8-Pin Ceramic Flat Pack (HKX)
- Compatible With ISO 11898-2
- Bus Pins Fault Protection Exceeds ±16 V
- Bus Pins ESD Protection Exceeds ±16 kV HBM
- Data Rates up to 1 Mbps
- Extended –7-V to 12-V Common Mode Range
- High Input Impedance Allows for 120 Nodes
- LVTTTL I/Os are 5-V Tolerant
- Adjustable Driver Transition Times for Improved Signal Quality
- Unpowered Node Does Not Disturb the Bus
- Low Current Standby Mode, 200-μA Typical
- Loopback for Diagnostic Functions
- Thermal Shutdown Protection
- Power Up and Power Down With Glitch-Free Bus Inputs and Outputs
 - High Input Impedance With Low V_{CC}
 - Monolithic Output During Power Cycling

2 Applications

- Spacecraft Backplane Data Bus Communication and Control
- CAN Bus Standards Such As CANopen, DeviceNet, CAN Kingdom, ISO 11783, NMEA 2000, SAE J1939

3 Description

The SN55HVD233-SP is used in spacecraft applications employing the controller area network (CAN) serial communication physical layer in accordance with the ISO 11898 standard. As a CAN transceiver, the device provides transmit and receive capability between the differential CAN bus and a CAN controller, with signaling rates up to 1 Mbps.

Designed for operation in especially harsh radiation environments, the SN55HVD233-SP features cross-wire, overvoltage, and loss of ground protection to ±16 V, overtemperature (thermal shutdown) protection. This device operates over a wide –7-V to 12-V common mode range. This transceiver is the interface between the host CAN controller on the microprocessor, FPGA, or ASIC, and the differential CAN bus used in satellite applications.

Device Information⁽¹⁾

PART NUMBER	GRADE	PACKAGE
5962L1420901VXC	QMLV RHA [50 kRad]	8-lead CFP [HKX] 6.48 mm × 6.48 mm
HVD233HKX/EM ⁽²⁾	Engineering Samples	8-lead CFP [HKX] 6.48 mm × 6.48 mm
SN55HVD233EVM-CVAL	Ceramic Evaluation Board	

(1) For all available packages, see the orderable addendum at the end of the data sheet.

(2) These units are intended for engineering evaluation only. They are processed to a noncompliant flow. These units are not suitable for qualification, production, radiation testing or flight use. Parts are not warranted for performance over the full MIL specified temperature range of –55°C to 125°C or operating life.

Simplified Schematic

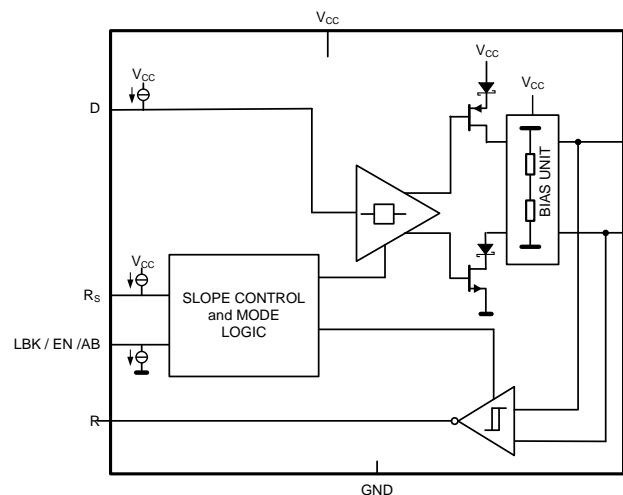

Copyright © 2017, Texas Instruments Incorporated



Table of Contents

1 Features	1	9.1 Overview	15
2 Applications	1	9.2 Functional Block Diagram	15
3 Description	1	9.3 Feature Description	15
4 Revision History	2	9.4 Device Functional Modes	19
5 Description (continued)	3	10 Application and Implementation	20
6 Pin Configuration and Functions	3	10.1 Application Information	20
7 Specifications	4	10.2 Typical Application	22
7.1 Absolute Maximum Ratings	4	11 Power Supply Recommendations	24
7.2 ESD Ratings	4	12 Layout	24
7.3 Recommended Operating Conditions	4	12.1 Layout Guidelines	24
7.4 Thermal Information	5	12.2 Layout Example	26
7.5 Driver Electrical Characteristics	6	13 Device and Documentation Support	27
7.6 Receiver Electrical Characteristics	6	13.1 Receiving Notification of Documentation Updates	27
7.7 Driver Switching Characteristics	7	13.2 Community Resources	27
7.8 Receiver Switching Characteristics	8	13.3 Trademarks	27
7.9 Device Switching Characteristics	8	13.4 Electrostatic Discharge Caution	27
7.10 Typical Characteristics	9	13.5 Glossary	27
8 Parameter Measurement Information	11	14 Mechanical, Packaging, and Orderable Information	27
9 Detailed Description	15		

4 Revision History

Changes from Original (September 2017) to Revision A	Page
• Changed the device status from <i>Advance Information</i> to <i>Production Data</i>	1

5 Description (continued)

Modes: The R_S , pin 8 of the SN55HVD233-SP, provides for three modes of operation: high-speed, slope control, or low-power standby mode. The user selects the high-speed mode of operation by connecting pin 8 directly to ground, allowing the driver output transistors to switch on and off as fast as possible with no limitation on the rise and fall slope. The user can adjust the rise and fall slope by connecting a resistor to ground at pin 8, because the slope is proportional to the pin's output current. Slope control is implemented with a resistor values of $0\ \Omega$ to achieve a single ended slew rate of approximately $38\ \text{V}/\mu\text{s}$ up to a value of $50\ \text{k}\Omega$ to achieve approximately $4\ \text{V}/\mu\text{s}$ slew rate. For more information about slope control, refer to the [Application and Implementation](#) section.

The SN55HVD233-SP enters a low-current standby (listen-only) mode during which the driver is switched off and the receiver remains active if a high logic level is applied to pin 8. The local protocol controller reverses this low-current standby mode when it needs to transmit to the bus. For more information on the loopback mode, refer to the [Application Information](#) section.

Loopback: A logic high on the loopback LBK pin 5 of the SN55HVD233-SP places the bus output and bus input in a high-impedance state. The remaining circuit remains active and available for driver-to-receiver loopback, self-diagnostic node functions without disturbing the bus.

CAN bus states: The CAN bus has two states during powered operation of the device: dominant and recessive. A dominant bus state is when the bus is driven differentially, corresponding to a logic low on the D and R pin. A recessive bus state is when the bus is biased to $V_{CC} / 2$ through the high-resistance internal input resistors R_{IN} of the receiver, corresponding to a logic high on the D and R pins (see [Bus States \(Physical Bit Representation\)](#) and [Simplified Recessive Common Mode Bias and Receiver](#)).

6 Pin Configuration and Functions

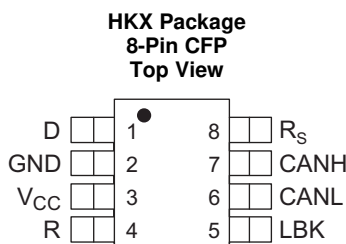

Pin Functions

PIN		TYPE	DESCRIPTION
NAME	NO.		
D	1	I	CAN transmit data input (LOW for dominant and HIGH for recessive bus states), also called TXD, driver input.
GND	2	GND	Ground connection.
V_{CC}	3	Supply	Transceiver 3.3-V supply voltage.
R	4	O	CAN receive data output (LOW for dominant and HIGH for recessive bus states), also called RXD, receiver output.
LBK	5	I	Loopback mode input pin.
CANL	6	I/O	Low-level CAN bus line.
CANH	7	I/O	High-level CAN bus line.
RS	8	I	Mode select pin: Tie to GND = high-speed mode, Strong pullup to V_{CC} = low power mode, $0\text{-}\Omega$ to $50\text{-k}\Omega$ pulldown to GND = slope control mode.

7 Specifications

7.1 Absolute Maximum Ratings

over operating junction temperature unless otherwise noted⁽¹⁾⁽²⁾

		MIN	MAX	UNIT
V _{CC}	Supply voltage	-0.3	7	V
	Voltage at any bus pin (CANH or CANL)	-16	16	V
	Voltage input, transient pulse, CANH and CANL, through 100 Ω (see Figure 18)	-100	100	V
V _I	Input voltage, (D, RS, LBK)	-0.5	7	V
V _O	Output voltage, (R)	-0.5	7	V
I _O	Receiver output current	-10	10	mA
T _J	Operating junction temperature		150	°C
T _{stg}	Storage temperature	-65	150	°C

- (1) Stresses beyond those listed under *Absolute Maximum Ratings* may cause permanent damage to the device. These are stress ratings only, and functional operation of the device at these or any other conditions beyond those indicated under *Recommended Operating Conditions* is not implied. Exposure to absolute-maximum-rated conditions for extended periods may affect device reliability.
- (2) All voltage values, except differential I/O bus voltages, are with respect to network ground pin.

7.2 ESD Ratings

			VALUE	UNIT	
V _(ESD)	Electrostatic discharge	Human-body model (HBM), per ANSI/ESDA/JEDEC JS-001 ⁽¹⁾	CANH, CANL, and GND	±14000	V
			Other pins	±4000	
		Charged-device model (CDM), per JEDEC specification JESD22-C101, all pins ⁽²⁾		±500	

- (1) JEDEC document JEP155 states that 500-V HBM allows safe manufacturing with a standard ESD control process.
- (2) JEDEC document JEP157 states that 250-V CDM allows safe manufacturing with a standard ESD control process.

7.3 Recommended Operating Conditions

			MIN	NOM	MAX	UNIT
V _{CC}	Supply voltage		3		3.6	V
	Voltage at any bus pin (separately or common mode)		-7		12	V
V _{IH}	High-level input voltage	D, LBK	2		5.5	V
V _{IL}	Low-level input voltage	D, LBK	0		0.8	V
V _{ID}	Differential input voltage		-6		6	V
	Resistance from RS to ground for slope control		0		50	kΩ
V _{I(RS)}	Input voltage at RS for standby		0.75 V _{CC}		5.5	V
I _{OH}	High-level output current	Driver	-50			mA
		Receiver	-10			
I _{OL}	Low-level output current	Driver			50	mA
		Receiver			10	
T _J	Operating junction temperature ⁽¹⁾		-55		125	°C

- (1) Maximum junction temperature operation is allowed as long as the device maximum junction temperature is not exceeded.

7.4 Thermal Information

THERMAL METRIC ⁽¹⁾⁽²⁾		SN55HVD233-SP	
		HKX (CFP)	
		8 PINS	
			UNIT
$R_{\theta JA}$	Junction-to-ambient thermal resistance	97.1	°C/W
$R_{\theta JC(top)}$	Junction-to-case (top) thermal resistance	21.5	°C/W
$R_{\theta JB}$	Junction-to-board thermal resistance	79.1	°C/W
Ψ_{JT}	Junction-to-top characterization parameter	13.7	°C/W
Ψ_{JB}	Junction-to-board characterization parameter	73.6	°C/W
$R_{\theta JC(bot)}$	Junction-to-case (bottom) thermal resistance	7.0	°C/W

- (1) All values except $R_{\theta JC}$ were taken on a JEDEC-51 standard High-K PCB using a nominal lead form. Differences in lead form, component density, or PCB design can affect these values.
- (2) For more information about traditional and new thermal metrics, see the *Semiconductor and IC Package Thermal Metrics* application report, [SPRA953](#).

7.5 Driver Electrical Characteristics

The specifications shown below are valid across temperature range of -55°C to 125°C pre-radiation and 25°C post-radiation. When different, the post-radiation values are shown in a separate row specified by the corresponding RHA level (L = 50 krad).

PARAMETER		TEST CONDITIONS		SUBGROUP ⁽¹⁾	MIN	TYP ⁽²⁾	MAX	UNIT	
$V_{O(D)}$	Bus output voltage (dominant)	CANH	$V_{(D)} = 0\text{ V}$, $V_{(RS)} = 0\text{ V}$, see Figure 12 and Figure 13	[1, 2, 3]	2.4		V_{CC}	V	
		CANL		[1, 2, 3]	0.5	1.25			
V_O	Bus output voltage (recessive)	CANH	$V_{(D)} = 3\text{ V}$, $V_{(RS)} = 0\text{ V}$, see Figure 12 and Figure 13			2.3		V	
		CANL				2.3			
$V_{OD(D)}$	Differential output voltage (dominant)		$V_{(D)} = 0\text{ V}$, $V_{(RS)} = 0\text{ V}$, see Figure 12 and Figure 13	L	[1, 2, 3]	1.5	2	3	V
					[1, 2, 3]	1.4			
V_{OD}	Differential output voltage (recessive)		$V_{(D)} = 0\text{ V}$, $V_{(RS)} = 0\text{ V}$, see Figure 13 and Figure 14	[1, 2, 3]	1.2	2	3	V	
				[1, 2, 3]					
V_{OD}	Differential output voltage (recessive)		$V_{(D)} = 3\text{ V}$, $V_{(RS)} = 0\text{ V}$, see Figure 12 and Figure 13	[1, 2, 3]	-120		12	mV	
				[1, 2, 3]	-0.5	0.05	V		
$V_{OC(pp)}$	Peak-to-peak common-mode output voltage		See Figure 20			1		V	
I_{IH}	High-level input current	D, LBK	$V_{(D)} = 2\text{ V}$	[1, 2, 3]	-30		30	μA	
I_{IL}	Low-level input current	D, LBK	$V_{(D)} = 0.8\text{ V}$	[1, 2, 3]	-30		30	μA	
I_{OS}	Short-circuit output current		$V_{(CANH)} = -7\text{ V}$, CANL open, see Figure 23	[1, 2, 3]	-250			mA	
			$V_{(CANH)} = 12\text{ V}$, CANL open, see Figure 23	[1, 2, 3]			1		
			$V_{(CANL)} = -7\text{ V}$, CANH open, see Figure 23	[1, 2, 3]	-1				
			$V_{(CANL)} = 12\text{ V}$, CANH open, see Figure 23	[1, 2, 3]			250		
C_O	Output capacitance		See receiver input capacitance						
$I_{IRS(s)}$	RS input current for standby		$V_{(RS)} = 0.75 V_{CC}$	[1, 2, 3]	-10			μA	
I_{CC}	Supply current	Standby	$V_{(RS)} = V_{CC}$, $V_{(D)} = V_{CC}$, $V_{(LBK)} = 0\text{ V}$	[1, 2, 3]		200	600	μA	
		Dominant	$V_{(D)} = 0\text{ V}$, no load, $V_{(LBK)} = 0\text{ V}$, $V_{(RS)} = 0\text{ V}$	[1, 2, 3]			6	mA	
		Recessive	$V_{(D)} = V_{CC}$, no load, $V_{(LBK)} = 0\text{ V}$, $V_{(RS)} = 0\text{ V}$	[1, 2, 3]			6		

(1) For subgroup definitions, please see [Table 1](#).

(2) All typical values are at 25°C and with a 3.3-V supply.

7.6 Receiver Electrical Characteristics

The specifications shown below are valid across temperature range of -55°C to 125°C pre-radiation and 25°C post-radiation. When different, the post-radiation values are shown in a separate row specified by the corresponding RHA level (L = 50 krad).

PARAMETER		TEST CONDITIONS		SUBGROUP ⁽¹⁾	MIN	TYP ⁽²⁾	MAX	UNIT
V_{IT+}	Positive-going input threshold voltage		$V_{(LBK)} = 0\text{ V}$, see Table 2	[1, 2, 3]		750	900	mV
V_{IT-}	Negative-going input threshold voltage			[1, 2, 3]	500	650		mV
V_{hys}	Hysteresis voltage ($V_{IT+} - V_{IT-}$)					100		mV
V_{OH}	High-level output voltage		$I_O = -4\text{ mA}$, see Figure 17	[1, 2, 3]	2.4			V
V_{OL}	Low-level output voltage		$I_O = 4\text{ mA}$, see Figure 17	[1, 2, 3]			0.4	V

(1) For subgroup definitions, please see [Table 1](#).

(2) All typical values are at 25°C and with a 3.3-V supply.

Receiver Electrical Characteristics (continued)

The specifications shown below are valid across temperature range of -55°C to 125°C pre-radiation and 25°C post-radiation. When different, the post-radiation values are shown in a separate row specified by the corresponding RHA level (L = 50 krad).

PARAMETER		TEST CONDITIONS	SUBGROUP ⁽¹⁾	MIN	TYP ⁽²⁾	MAX	UNIT
I_I	Bus input current	$V_{(\text{CANH})}$ or $V_{(\text{CANL})} = 12\text{ V}$	[1, 2, 3]	150		500	μA
		$V_{(\text{CANH})}$ or $V_{(\text{CANL})} = 12\text{ V}$, $V_{\text{CC}} = 0\text{ V}$	Other bus pin = 0 V, $V_{(\text{D})} = 3\text{ V}$, $V_{(\text{LBK})} = 0\text{ V}$, $V_{(\text{RS})} = 0\text{ V}$	[1, 2, 3]	150	600	
		CANH or CANL = -7 V		[1, 2, 3]	-610	-100	
		CANH or CANL = -7 V , $V_{\text{CC}} = 0\text{ V}$		[1, 2, 3]	-450	-100	
C_I	Input capacitance (CANH or CANL)	Pin-to-ground, $V_I = 0.4 \sin(4E6\pi t) + 0.5\text{ V}$, $V_{(\text{D})} = 3\text{ V}$, $V_{(\text{LBK})} = 0\text{ V}$			40	pF	
C_{ID}	Differential input capacitance	Pin-to-pin, $V_I = 0.4 \sin(4E6\pi t) + 0.5\text{ V}$, $V_{(\text{D})} = 3\text{ V}$, $V_{(\text{LBK})} = 0\text{ V}$			20	pF	
R_{ID}	Differential input resistance		[4, 5, 6]	40		105	$\text{k}\Omega$
R_{IN}	Input resistance (CANH or CANL)	$V_{(\text{D})} = 3\text{ V}$, $V_{(\text{LBK})} = 0\text{ V}$	[4, 5, 6]	20		55	$\text{k}\Omega$
I_{CC}	Supply current	Standby	$V_{(\text{RS})} = V_{\text{CC}}$, $V_{(\text{D})} = V_{\text{CC}}$, $V_{(\text{LBK})} = 0\text{ V}$	[1, 2, 3]	200	600	μA
		Dominant	$V_{(\text{D})} = 0\text{ V}$, no load, $V_{(\text{RS})} = 0\text{ V}$, $V_{(\text{LBK})} = 0\text{ V}$	[1, 2, 3]		6	mA
		Recessive	$V_{(\text{D})} = V_{\text{CC}}$, no load, $V_{(\text{RS})} = 0\text{ V}$, $V_{(\text{LBK})} = 0\text{ V}$	[1, 2, 3]		6	mA

7.7 Driver Switching Characteristics

The specifications shown below are valid across temperature range of -55°C to 125°C pre-radiation and 25°C post-radiation. When different, the post-radiation values are shown in a separate row specified by the corresponding RHA level (L = 50 krad).

PARAMETER		TEST CONDITIONS	SUBGROUP ⁽¹⁾	MIN	TYP ⁽²⁾	MAX	UNIT
t_{PLH}	Propagation delay time, low-to-high-level output	$V_{(\text{RS})} = 0\text{ V}$, see Figure 15	[9, 10, 11]		35	85	ns
		RS with 10 $\text{k}\Omega$ to ground, see Figure 15	[9, 10, 11]		70	125	
		RS with 50 $\text{k}\Omega$ to ground, see Figure 15	[9, 10, 11]		500	870	
t_{PHL}	Propagation delay time, high-to-low-level output	$V_{(\text{RS})} = 0\text{ V}$, see Figure 15	[9, 10, 11]		70	120	ns
		RS with 10 $\text{k}\Omega$ to ground, see Figure 15	[9, 10, 11]		130	180	
		RS with 50 $\text{k}\Omega$ to ground, see Figure 15	[9, 10, 11]		870	1200	
$t_{\text{sk(p)}}$	Pulse skew ($ t_{\text{PHL}} - t_{\text{PLH}} $)	$V_{(\text{RS})} = 0\text{ V}$, see Figure 15			35		ns
		RS with 10 $\text{k}\Omega$ to ground, see Figure 15			60		
		RS with 50 $\text{k}\Omega$ to ground, see Figure 15			370		
t_r	Differential output signal rise time	$V_{(\text{RS})} = 0\text{ V}$, see Figure 15	[9, 10, 11]	20		70	ns
t_f	Differential output signal fall time		[9, 10, 11]	20		70	ns
t_r	Differential output signal rise time	RS with 10 $\text{k}\Omega$ to ground, see Figure 15	[9, 10, 11]	30		135	ns
t_f	Differential output signal fall time		[9, 10, 11]	30		135	ns
t_r	Differential output signal rise time	RS with 50 $\text{k}\Omega$ to ground, see Figure 15	[9, 10, 11]	350		1400	ns
t_f	Differential output signal fall time		[9, 10, 11]	350		1400	ns
$t_{\text{en(s)}}$	Enable time from standby to dominant	See Figure 19	[9, 10, 11]		0.6	1.5	μs

(1) For subgroup definitions, please see [Table 1](#).

(2) All typical values are at 25°C and with a 3.3-V supply.

7.8 Receiver Switching Characteristics

The specifications shown below are valid across temperature range of –55°C to 125°C pre-radiation and 25°C post-radiation. When different, the post-radiation values are shown in a separate row specified by the corresponding RHA level (L = 50 krad).

PARAMETER		TEST CONDITIONS	SUBGROUP ⁽¹⁾	MIN	TYP ⁽²⁾	MAX	UNIT
t_{PLH}	Propagation delay time, low-to-high-level output	See Figure 17	[9, 10, 11]	35	105		ns
t_{PHL}	Propagation delay time, high-to-low-level output		[9, 10, 11]	35	105		ns
$t_{sk(p)}$	Pulse skew ($t_{PHL} - t_{PLH}$)				7		ns
t_r	Output signal rise time				2		ns
t_f	Output signal fall time				2		ns

(1) For subgroup definitions, please see Table 1.

(2) All typical values are at 25°C and with a 3.3-V supply.

7.9 Device Switching Characteristics

The specifications shown below are valid across temperature range of –55°C to 125°C pre-radiation and 25°C post-radiation. When different, the post-radiation values are shown in a separate row specified by the corresponding RHA level (L = 50 krad).

PARAMETER		TEST CONDITIONS	SUBGROUP ⁽¹⁾	MIN	TYP ⁽²⁾	MAX	UNIT
$t_{(LBK)}$	Loopback delay, driver input to receiver output	See Figure 22			7.5		ns
$t_{(loop1)}$	Total loop delay, driver input to receiver output, recessive to dominant	$V_{(RS)}$ at 0 V, see Figure 21	[9, 10, 11]		70	150	ns
		$V_{(RS)}$ with 10 kΩ to ground, see Figure 21	[9, 10, 11]		105	225	
		$V_{(RS)}$ with 50 kΩ to ground, see Figure 21	[9, 10, 11]		500	600	
$t_{(loop2)}$	Total loop delay, driver input to receiver output, dominant to recessive	$V_{(RS)}$ at 0 V, See Figure 21	[9, 10, 11]		70	150	ns
		$V_{(RS)}$ with 10 kΩ to ground, see Figure 21	[9, 10, 11]		105	225	
		$V_{(RS)}$ with 50 kΩ to ground, see Figure 21	[9, 10, 11]		500	600	

(1) For subgroup definitions, please see Table 1.

(2) All typical values are at 25°C and with a 3.3-V supply.

Table 1. Quality Conformance Inspection⁽¹⁾

SUBGROUP	DESCRIPTION	TEMPERATURE (°C)
1	Static tests at	25
2	Static tests at	125
3	Static tests at	–55
4	Dynamic tests at	25
5	Dynamic tests at	125
6	Dynamic tests at	–55
7	Functional tests at	25
8A	Functional tests at	125
8B	Functional tests at	–55
9	Switching tests at	25
10	Switching tests at	125
11	Switching tests at	–55

(1) MIL-STD-883, Method 5005 - Group A

7.10 Typical Characteristics

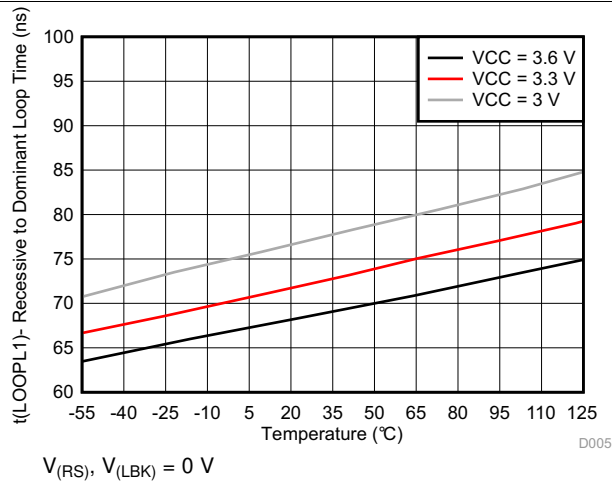

Figure 1. Recessive-To-Dominant Loop Time vs Temperature

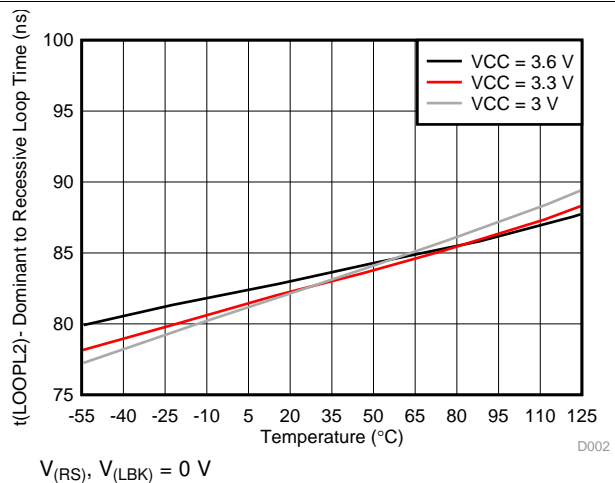

Figure 2. Dominant-To-Recessive Loop Time vs Temperature

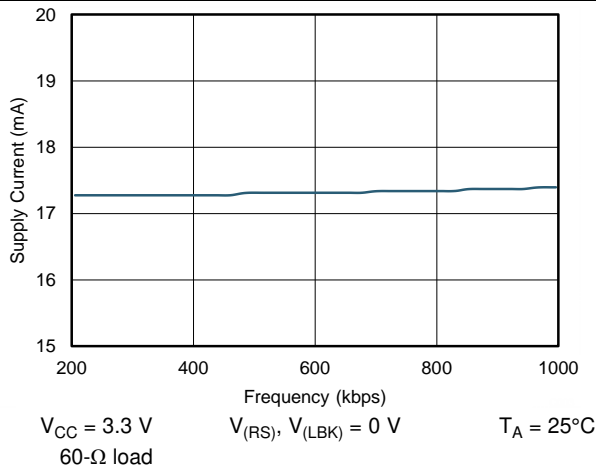

Figure 3. Supply Current vs Frequency

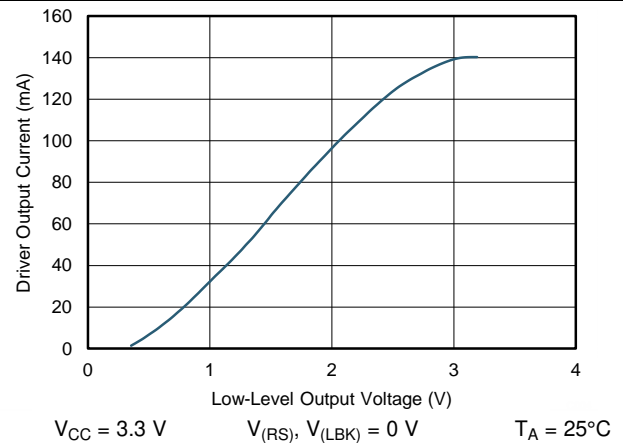

Figure 4. Driver Low-Level Output Current vs Low-Level Output Voltage

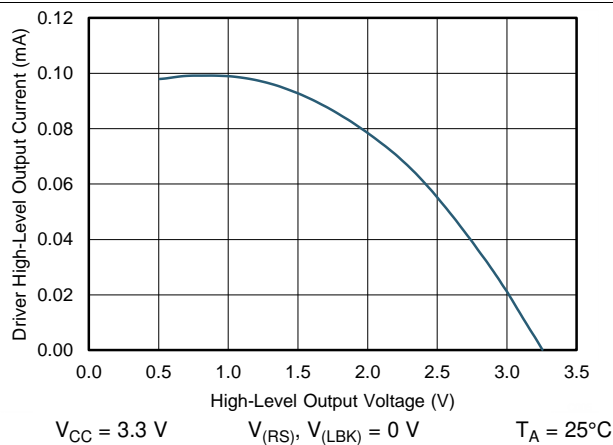

Figure 5. Driver High-Level Output Current vs High-Level Output Voltage

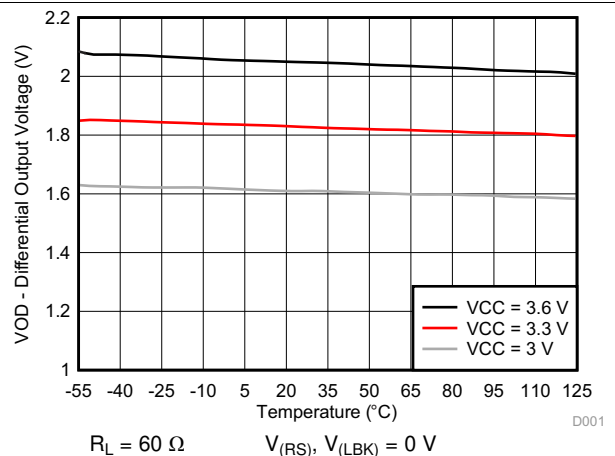

Figure 6. Differential Output Voltage vs Temperature

Typical Characteristics (continued)

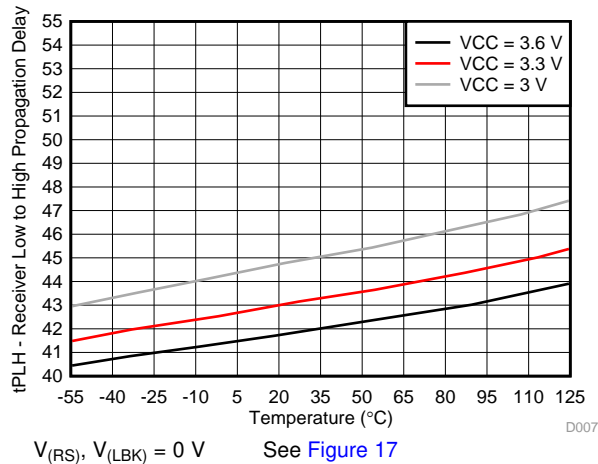

Figure 7. Receiver Low-To-High Propagation Delay vs Temperature

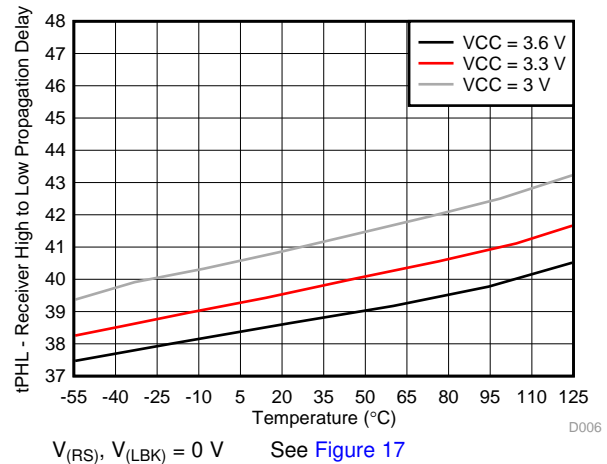

Figure 8. Receiver High-To-Low Propagation Delay vs Temperature

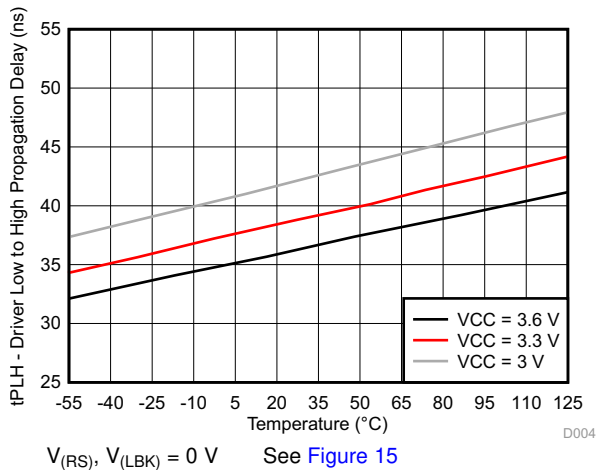

Figure 9. Driver Low-To-High Propagation Delay vs Temperature

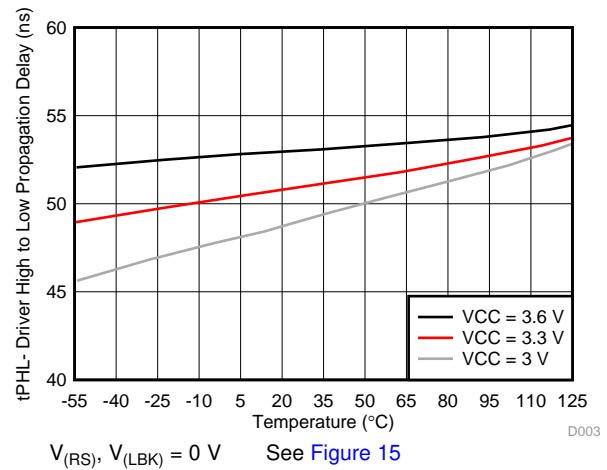

Figure 10. Driver High-To-Low Propagation Delay vs Temperature

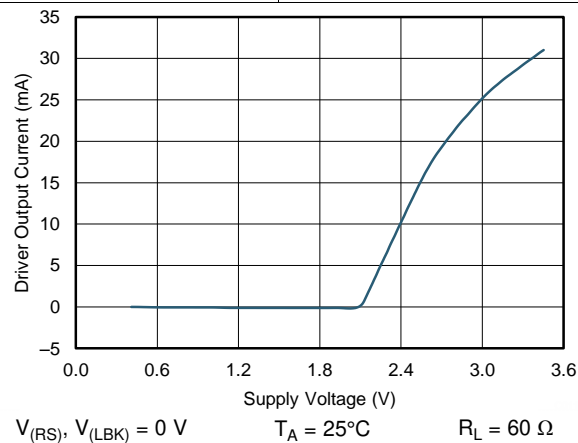

Figure 11. Driver Output Current vs Supply Voltage

8 Parameter Measurement Information

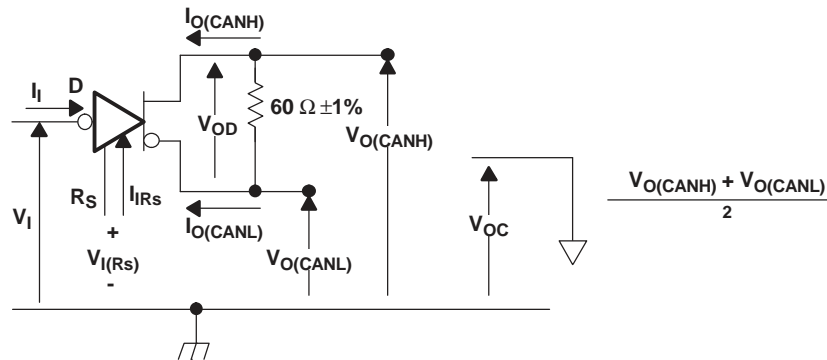

Figure 12. Driver Voltage, Current, and Test Definition

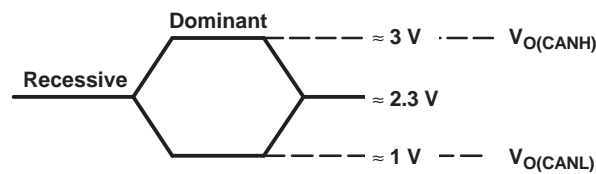

Figure 13. Bus Logic State Voltage Definitions

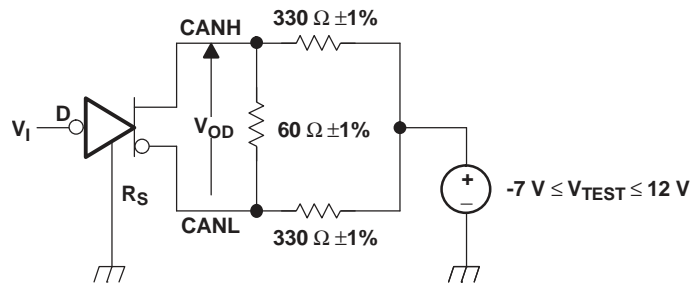
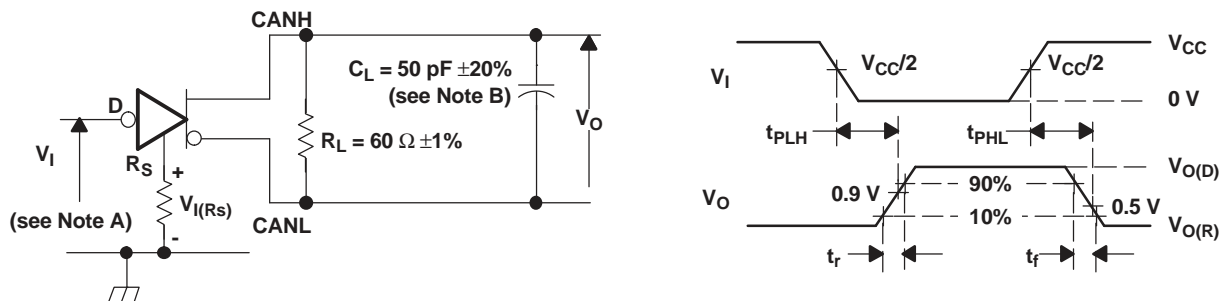

Figure 14. Driver V_{OD}



- A. The input pulse is supplied by a generator having the following characteristics:
- Pulse repetition rate (PRR) ≤ 125 kHz, 50% duty cycle
 - $t_r \leq 6$ ns
 - $t_f \leq 6$ ns
 - $Z_0 = 50 \Omega$
- B. C_L includes fixture and instrumentation capacitance.

Figure 15. Driver Test Circuit and Voltage Waveforms

Parameter Measurement Information (continued)

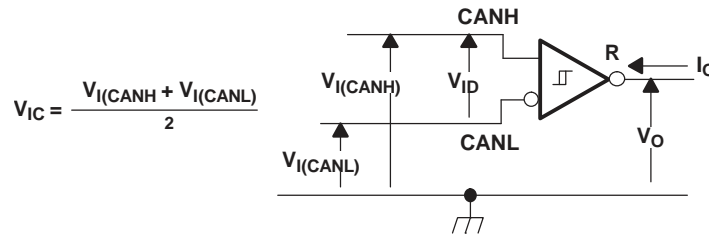
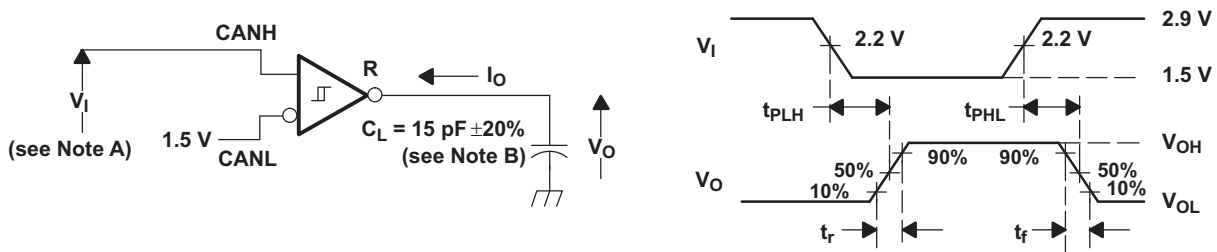

Figure 16. Receiver Voltage and Current Definitions



- A. The input pulse is supplied by a generator having the following characteristics:
- PRR ≤ 125 kHz, 50% duty cycle
 - $t_r \leq 6$ ns
 - $t_f \leq 6$ ns
 - $Z_O = 50 \Omega$
- B. C_L includes fixture and instrumentation capacitance.

Figure 17. Receiver Test Circuit and Voltage Waveforms

Table 2. Differential Input Voltage Threshold Test

INPUT		OUTPUT		MEASURED
V_{CANH}	V_{CANL}	R		$ V_{ID} $
-6.1 V	-7 V	L	V_{OL}	900 mV
12 V	11.1 V	L		900 mV
-1 V	-7 V	L		6 V
12 V	6 V	L		6 V
-6.5 V	-7 V	H	V_{OH}	500 mV
12 V	11.5 V	H		500 mV
-7 V	-1 V	H		6 V
6 V	12 V	H		6 V
Open	Open	H		X

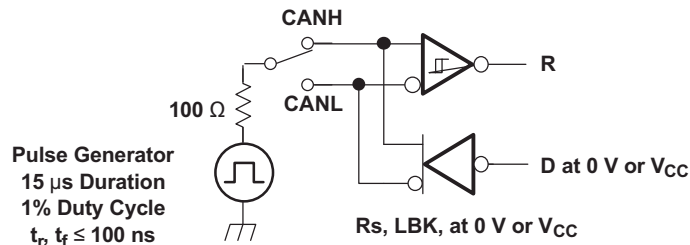

NOTE: This test is conducted to test survivability only. Data stability at the R output is not specified.

Figure 18. Test Circuit, Transient Overvoltage Test

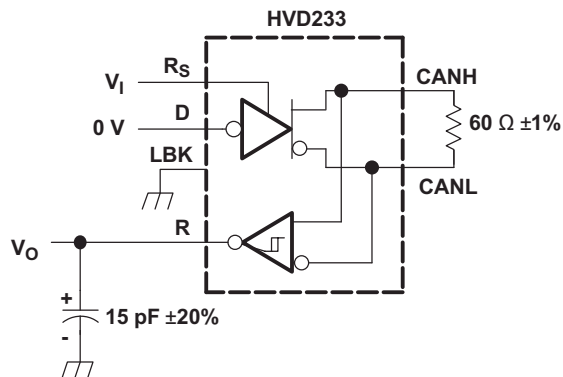

Copyright © 2017, Texas Instruments Incorporated

NOTE: All V_I input pulses are supplied by a generator having the following characteristics:

- t_r or $t_f \leq 6$ ns
- PRR = 125 kHz, 50% duty cycle

Figure 19. $T_{en(s)}$ Test Circuit and Voltage Waveforms

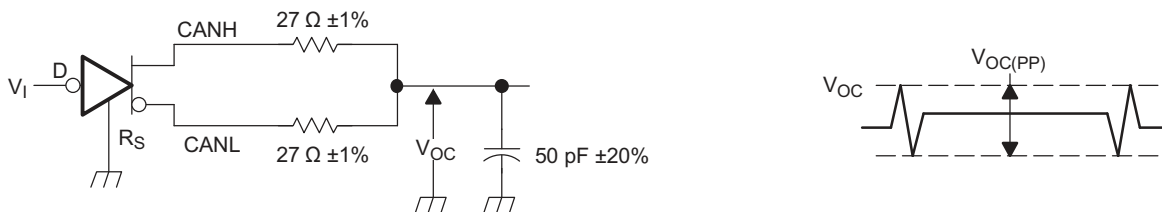

NOTE: All V_I input pulses are supplied by a generator having the following characteristics:

- t_r or $t_f \leq 6$ ns
- PRR = 125 kHz, 50% duty cycle

Figure 20. $V_{OC(pp)}$ Test Circuit and Voltage Waveforms

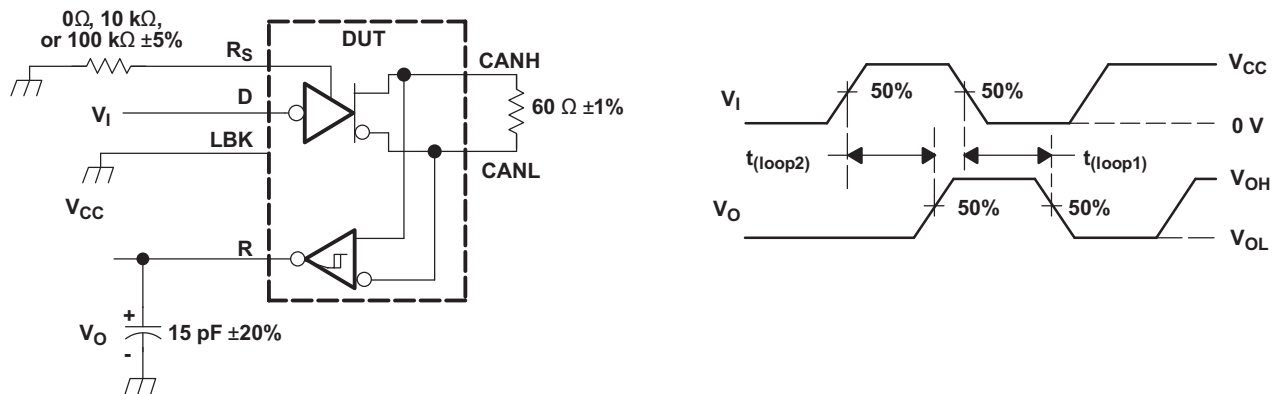
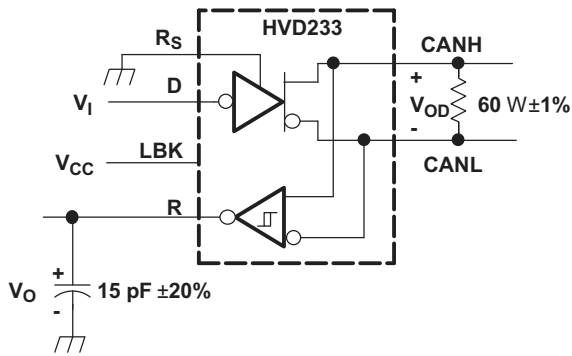

Figure 21. $T_{(loop)}$ Test Circuit and Voltage Waveforms



Copyright © 2017, Texas Instruments Incorporated

Figure 22. $T_{(LBK)}$ Test Circuit and Voltage Waveforms

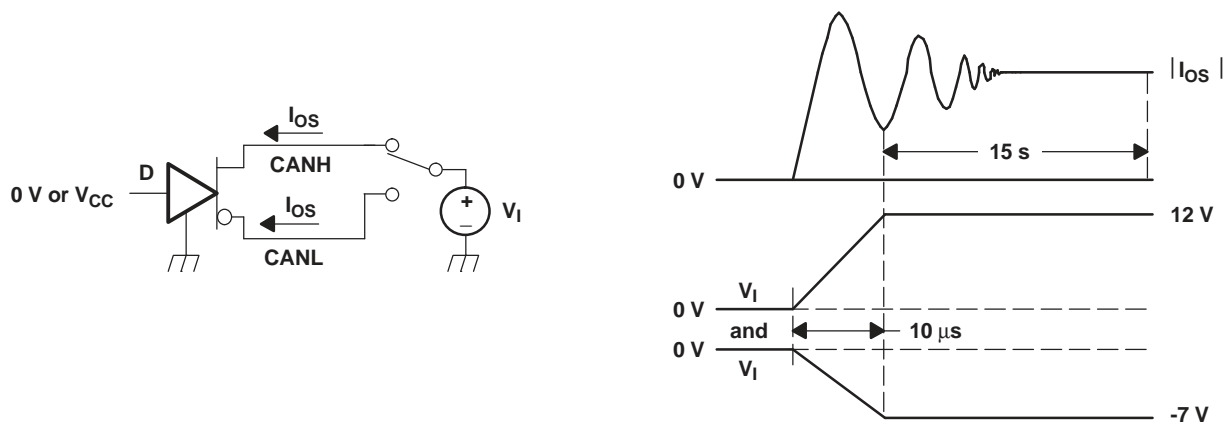
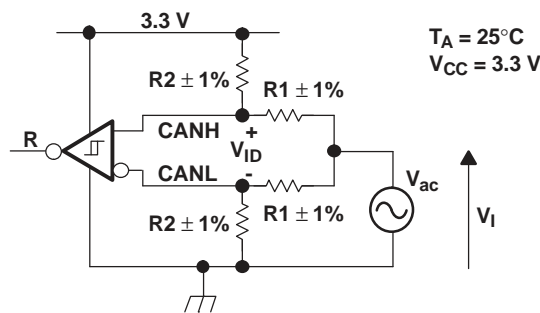

Figure 23. I_{0S} Test Circuit and Waveforms



The R Output State Does Not Change During Application of the Input Waveform.

V_{ID}	R1	R2
500 mV	50 Ω	280 Ω
900 mV	50 Ω	130 Ω



NOTE: All input pulses are supplied by a generator with $f \leq 1.5$ MHz.

Figure 24. Common-Mode Voltage Rejection

9 Detailed Description

9.1 Overview

The SN55HVD233-SP is used in applications employing the CAN serial communication physical layer in accordance with the ISO 11898 standard. As a CAN transceiver, the device provides transmit and receive capability between the differential CAN bus and a CAN controller, with signaling rates up to 1 Mbps.

Designed for operation in especially harsh environments, the SN55HVD233-SP features cross-wire, overvoltage, and loss of ground protection to ± 16 V, overtemperature (thermal shutdown) protection, and common-mode transient protection of ± 100 V. This device operates over a wide -7 -V to 12-V common mode range. This transceiver is the interface between the host CAN controller on the microprocessor, FPGA, or ASIC, and the differential CAN bus used in satellite applications.

9.2 Functional Block Diagram

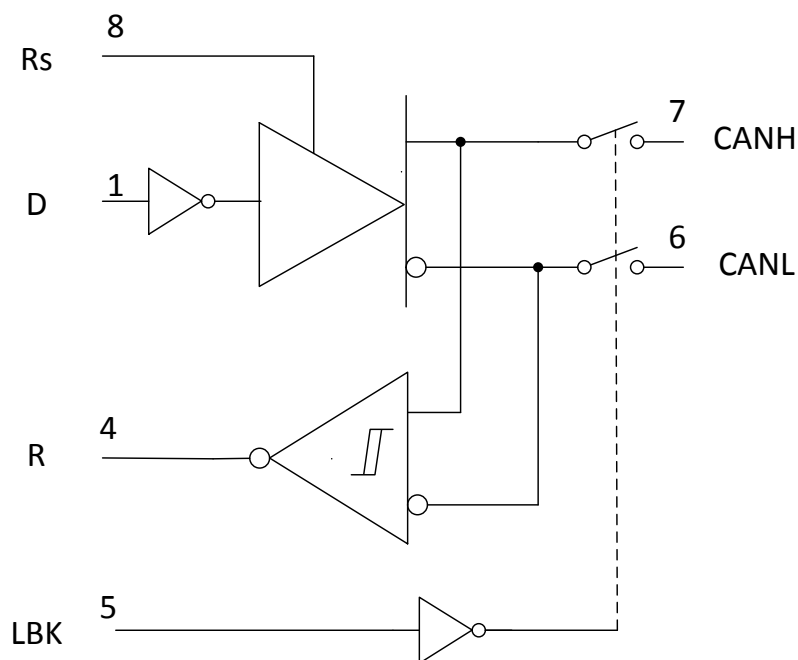

Copyright © 2017, Texas Instruments Incorporated

9.3 Feature Description

9.3.1 Modes

The R_S , pin 8 of the SN55HVD233-SP, provides for three modes of operation: high-speed, slope control, or low-power standby mode. The user selects the high-speed mode of operation by connecting pin 8 directly to ground, allowing the driver output transistors to switch on and off as fast as possible with no limitation on the rise and fall slope. The user can adjust the rise and fall slope by connecting a resistor to ground at pin 8, because the slope is proportional to the pin's output current. Slope control is implemented with a resistor values of 0Ω to achieve a single ended slew rate of approximately $38 \text{ V}/\mu\text{s}$ up to a value of $50 \text{ k}\Omega$ to achieve approximately $4 \text{ V}/\mu\text{s}$ slew rate. For more information about slope control, refer to [Application and Implementation](#).

The SN55HVD233-SP enters a low-current standby (listen-only) mode during which the driver is switched off and the receiver remains active if a high logic level is applied to pin 8. The local protocol controller reverses this low-current standby mode when it needs to transmit to the bus.

Feature Description (continued)

9.3.2 Loopback

A logic high on the loopback LBK pin 5 of the SN55HVD233-SP places the bus output and bus input in a high-impedance state. The remaining circuit remains active and available for driver-to-receiver loopback, self-diagnostic node functions without disturbing the bus. For more information on the loopback mode, refer to the [Application Information](#).

Feature Description (continued)

9.3.3 CAN Bus States

The CAN bus has two states during powered operation of the device: dominant and recessive. A dominant bus state is when the bus is driven differentially, corresponding to a logic low on the D and R pin. A recessive bus state is when the bus is biased to $V_{CC} / 2$ through the high-resistance internal input resistors R_{IN} of the receiver, corresponding to a logic high on the D and R pins (see Figure 25 and Figure 26).

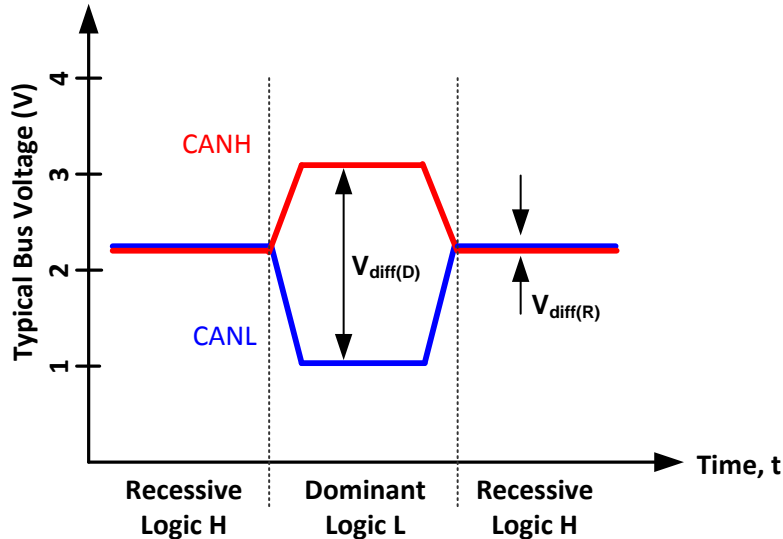

Figure 25. Bus States (Physical Bit Representation)

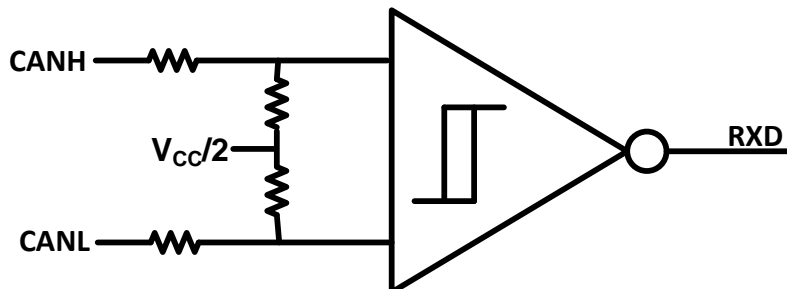

Figure 26. Simplified Recessive Common Mode Bias and Receiver

9.3.4 ISO 11898 Compliance of SN55HVD233-SP

9.3.4.1 Introduction

Many users value the low-power consumption of operating their CAN transceivers from a 3.3-V supply. However, some users are concerned about the interoperability with 5-V supplied transceivers on the same bus. This report analyzes this situation to address those concerns.

9.3.4.2 Differential Signal

CAN is a differential bus where complementary signals are sent over two wires and the voltage difference between the two wires defines the logical state of the bus. The differential CAN receiver monitors this voltage difference and outputs the bus state with a single-ended output signal.

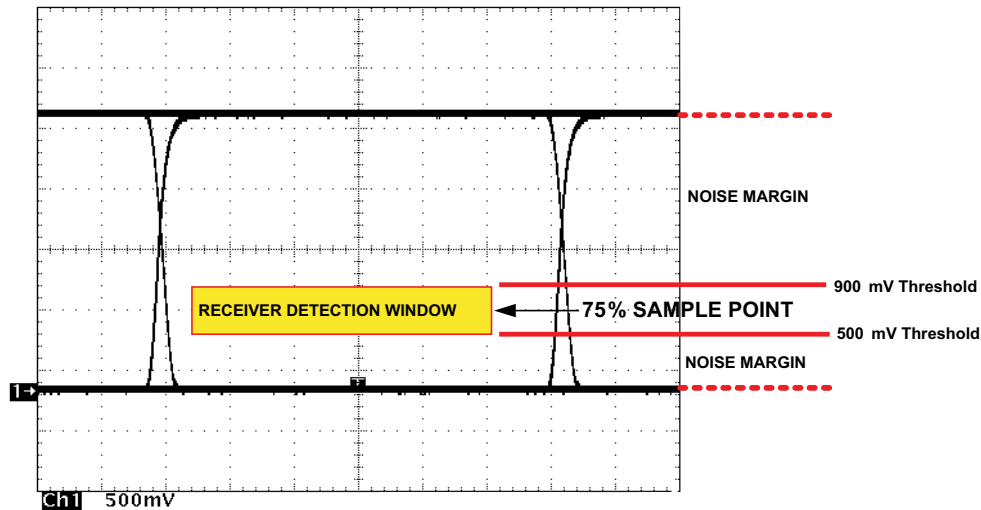
Feature Description (continued)

Figure 27. Typical SN55HVD233-SP Differential Output Voltage Waveform

The CAN driver creates the difference in voltage between CANH and CANL in the dominant state. The dominant differential output of the SN55HVD233-SP is greater than 1.5 V and less than 3 V across a 60-Ω load. The minimum required by ISO 11898 is 1.5 V and maximum is 3 V. These are the same limiting values for 5-V supplied CAN transceivers. The bus termination resistors drive the recessive bus state and not the CAN driver.

A CAN receiver is required to output a recessive state with less than 500 mV and a dominant state with more than 900 mV difference voltage on its bus inputs. The CAN receiver must do this with common-mode input voltages from –2 V to 7 V. The SN55HVD233-SP receiver meets these same input specifications as 5-V supplied receivers.

9.3.4.2.1 Common-Mode Signal

A common-mode signal is an average voltage of the two signal wires that the differential receiver rejects. The common-mode signal comes from the CAN driver, ground noise, and coupled bus noise. The supply voltage of the CAN transceiver has nothing to do with noise. The SN55HVD233-SP driver lowers the common-mode output in a dominant bit by a couple hundred millivolts from that of most 5-V drivers. While this does not fully comply with ISO 11898, this small variation in the driver common-mode output is rejected by differential receivers and does not effect data, signal noise margins, or error rates.

9.3.4.3 Interoperability of 3.3-V CAN in 5-V CAN Systems

The 3.3-V supplied CAN transceivers are electrically interchangeable with 5-V CAN transceivers. The differential output is the same. The recessive common mode output is the same. The dominant common mode output voltage is a couple hundred millivolts lower than 5 V supplied drivers, while the receivers exhibit identical specifications as 5-V devices.

To help ensure the widest interoperability possible, the SN55HVD233-SP successfully passed the internationally recognized GIFT ICT conformance and interoperability testing for CAN transceivers. Electrical interoperability does not always assure interchangeability, however. Most implementers of CAN buses recognize that ISO 11898 does not sufficiently specify the electrical layer and that strict standard compliance alone does not ensure full interchangeability. Interchangeability is ensured with thorough equipment testing.

Feature Description (continued)

9.3.5 Thermal Shutdown

If the junction temperature of the device exceeds the thermal shutdown threshold, the device turns off the CAN driver circuits thus blocking the D pin to bus transmission path. The shutdown condition is cleared when the junction temperature drops below the thermal shutdown temperature of the device. The CAN bus pins are high-impedance biased to recessive level during a thermal shutdown, and the receiver-to-R pin path remains operational.

9.4 Device Functional Modes

Table 3. Driver I/O

DRIVER ⁽¹⁾					
INPUTS			OUTPUTS		
D	LBK	RS	CANH	CANL	BUS STATE
X	X	$> 0.75 V_{CC}$	Z	Z	Recessive
L	L or open	$\leq 0.33 V_{CC}$	H	L	Dominant
H or open	X		Z	Z	Recessive
X	H	$\leq 0.33 V_{CC}$	Z	Z	Recessive

(1) H = High level; L = Low level; Z = High impedance; X = Irrelevant

Table 4. Receiver I/O

RECEIVER ⁽¹⁾			
INPUTS		OUTPUT	
BUS STATE	$V_{ID} = V_{(CANH)} - V_{(CANL)}$	D	R
Dominant	$V_{ID} \geq 0.9 V$	X	L
Recessive	$V_{ID} \leq 0.5 V$ or open	H or open	H
?	$0.5 V < V_{ID} < 0.9 V$	H or open	?
Dominant	$V_{ID} \geq 0.9 V$	X	L
Recessive	$V_{ID} \leq 0.5 V$ or open	H	H
Recessive	$V_{ID} \leq 0.5 V$ or open	L	L
?	$0.5 V < V_{ID} < 0.9 V$	L	L

(1) H = High level; L = Low level; Z = High impedance; X = Irrelevant; ? = Indeterminate

10 Application and Implementation

NOTE

Information in the following applications sections is not part of the TI component specification, and TI does not warrant its accuracy or completeness. TI's customers are responsible for determining suitability of components for their purposes. Customers should validate and test their design implementation to confirm system functionality.

10.1 Application Information

10.1.1 Diagnostic Loopback

The diagnostic loopback or internal loopback function of the SN55HVD233-SP is enabled with a high-level input on pin 7, LBK. This mode disables the driver output while keeping the bus pins biased to the recessive state. This mode also redirects the D data input (transmit data) through logic to the received data output (R), thus creating an internal loopback of the transmit-to-receive data path. This mimics the loopback that occurs normally with a CAN transceiver because the receiver loops back the driven output to the R (receive data) pin. This mode allows the host microprocessor to input and read back a bit sequence or CAN messages to perform diagnostic routines without disturbing the CAN bus. [Figure 33](#) shows a typical CAN bus application.

If the LBK pin is not used, it may be tied to ground (GND). However, it is pulled low internally (defaults to a low-level input) and may be left open if not in use.

Application Information (continued)

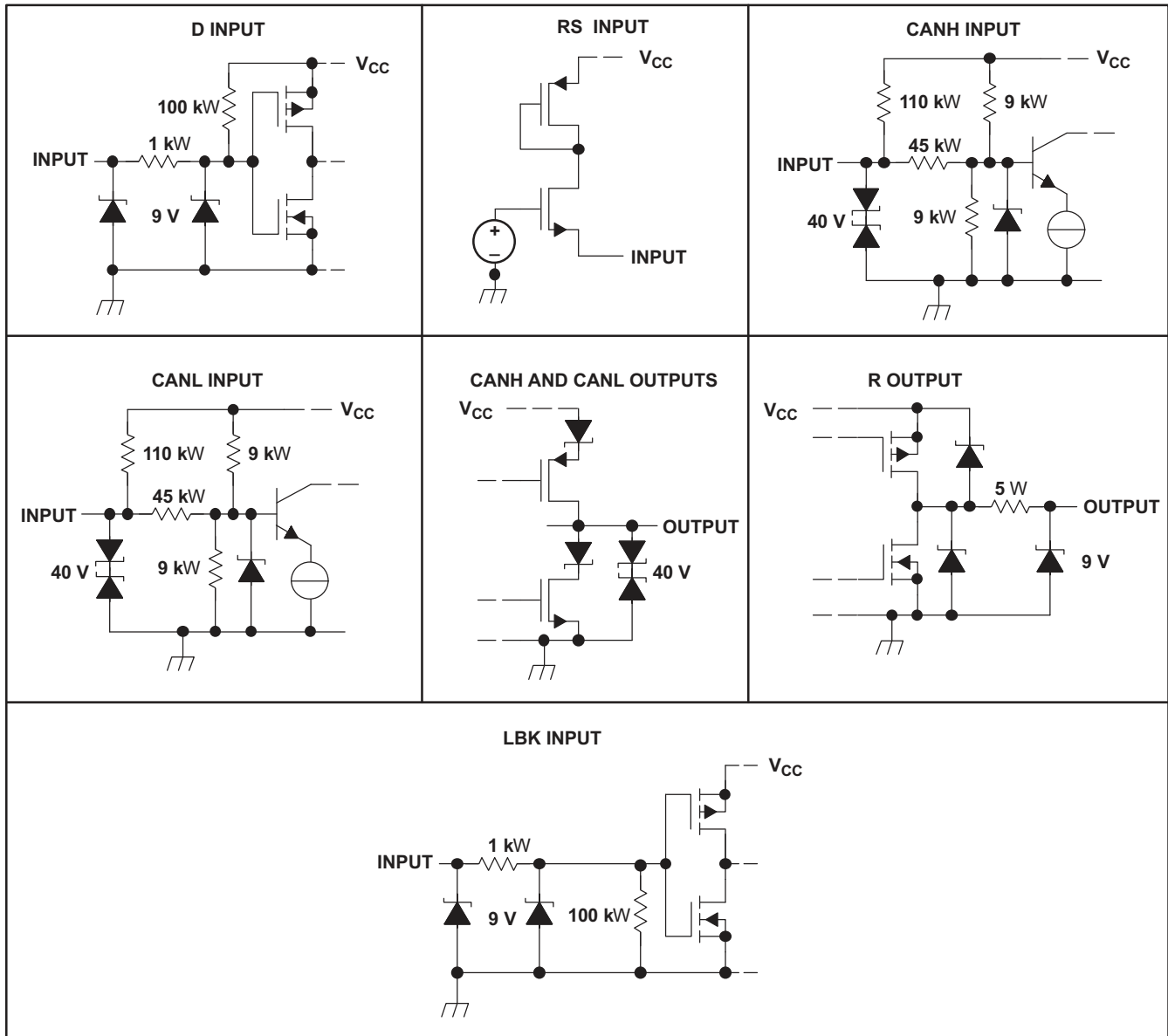

Copyright © 2017, Texas Instruments Incorporated

Figure 28. Equivalent Input and Output Schematic Diagrams

10.2 Typical Application

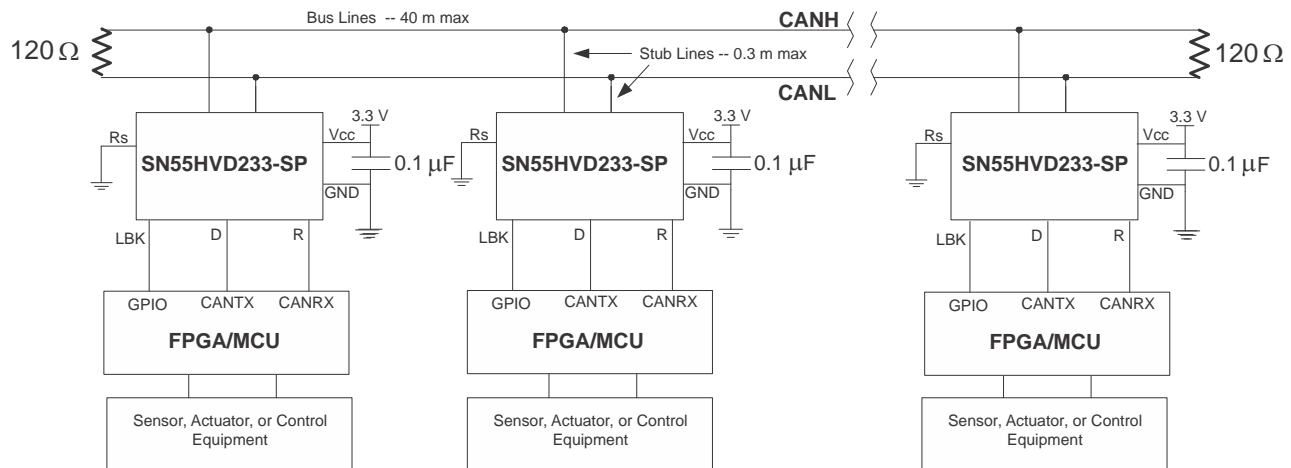

Copyright © 2017, Texas Instruments Incorporated

Figure 29. Typical Application Schematic

10.2.1 Design Requirements

The High-Speed ISO 11898 Standard specifications are given for a maximum signaling rate of 1 Mbps with a bus length of 40 m and a maximum of 30 nodes. It also recommends a maximum unterminated stub length of 0.3 m. The cable is specified to be a shielded or unshielded twisted-pair with a 120-Ω characteristic impedance (ZO). The standard defines a single line of twisted-pair cable with the network topology as shown in Figure 29. It is terminated at both ends with 120-Ω resistors, which match the characteristic impedance of the line to prevent signal reflections. According to ISO 11898, placing RL on a node should be avoided because the bus lines lose termination if the node is disconnected from the bus.

10.2.2 Detailed Design Procedure

Table 5. Suggested Cable Length vs Signaling Rate

BUS LENGTH (m)	SIGNALING RATE (Mbps)
40	1
100	0.5
200	0.25
500	0.1
1000	0.05

Basically, the maximum bus length is determined by, or rather is a trade-off with the selected signaling rate as listed in Table 5.

A signaling rate decreases as transmission distance increases. While steady-state losses may become a factor at the longest transmission distances, the major factors limiting signaling rate as distance is increased are time varying. Cable bandwidth limitations, which degrade the signal transition time and introduce inter-symbol interference (ISI), are primary factors reducing the achievable signaling rate when transmission distance is increased.

For a CAN bus, the signaling rate is also determined from the total system delay – down and back between the two most distant nodes of a system and the sum of the delays into and out of the nodes on a bus with the typical 5 ns/m prop delay of a twisted-pair cable. Also, consideration must be given the signal amplitude loss due to resistance of the cable and the input resistance of the transceivers. Under strict analysis, skin effects, proximity to other circuitry, dielectric loss, and radiation loss effects all act to influence the primary line parameters and degrade the signal.

A conservative rule of thumb for bus lengths over 100 m is derived from the product of the signaling rate in Mbps and the bus length in meters, which should be less than or equal to 50.

Signaling Rate (Mbps) × Bus Length (m) ≤ 50. Operation at extreme temperatures should employ additional conservatism.

10.2.2.1 Slope Control

Adjust the rise and fall slope of the SN55HVD233-SP driver output by connecting a resistor from the RS (pin 8) to ground (GND), or to a low-level input voltage as shown in Figure 30.

The slope of the driver output signal is proportional to the pin's output current. This slope control is implemented with an external resistor value ranging from 0 Ω to achieve a ≈38 V/μs single ended slew rate, and up to 50 kΩ to achieve a ≈4 V/μs slew rate as displayed in Figure 31. Figure 32 shows typical driver output waveforms with slope control.

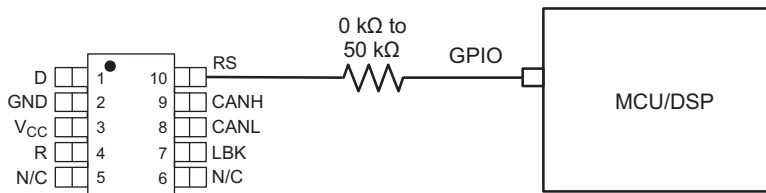
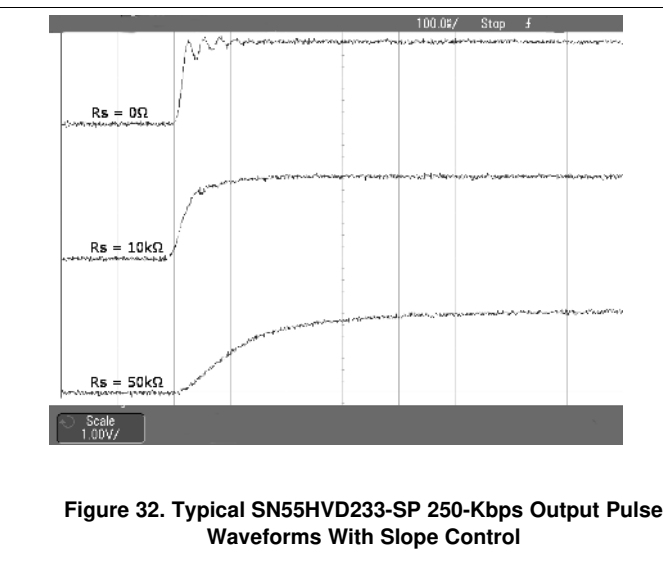
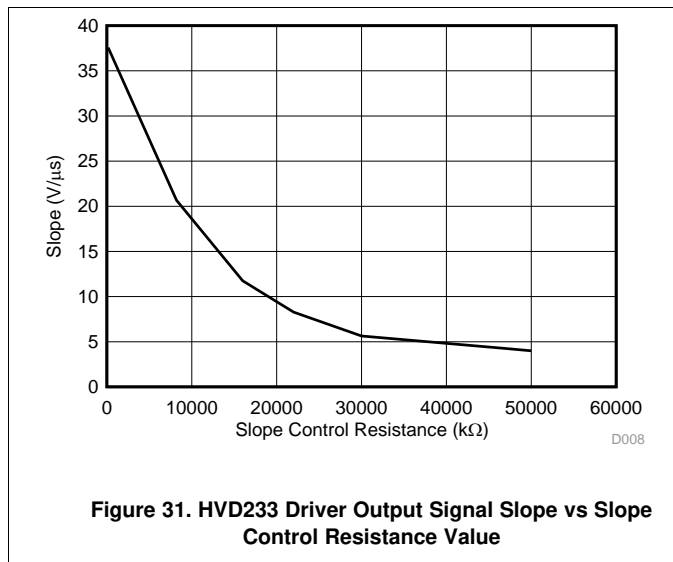

Figure 30. Slope Control/Standby Connection to a DSP

10.2.2.2 Standby

If a high-level input (> 0.75 V_{CC}) is applied to RS (pin 8), the circuit enters a low-current, listen-only standby mode during which the driver is switched off and the receiver remains active. The local controller can reverse this low-power standby mode when the rising edge of a dominant state (bus differential voltage > 900-mV typical) occurs on the bus.

10.2.3 Application Curves



11 Power Supply Recommendations

TI recommends to have localized capacitive decoupling near device VCC pin to GND. Values of 4.7 μF at VCC pin and 10 μF , 1 μF , and 0.1 μF at supply have tested well on evaluation modules.

12 Layout

12.1 Layout Guidelines

Minimize stub length from node insertion to bus.

12.1.1 Bus Loading, Length, and Number of Nodes

The ISO11898 standard specifies up to 1-Mbps data rate, maximum bus length of 40 m, maximum drop line (stub) length of 0.3 m, and a maximum of 30 nodes. However, with careful network design, the system may have longer cables, longer stub lengths, and many more nodes to a bus. Many CAN organizations and standards have scaled the use of CAN for applications outside the original ISO11898 standard. They made system level trade-offs for data rate, cable length, and parasitic loading of the bus. Examples of some of these specifications are ARINC825, CANopen, CAN Kingdom, DeviceNet, and NMEA200.

A high number of nodes requires a transceiver with high input impedance and wide common mode range such as the SN55HVD233-SP CAN. ISO11898-2 specifies the driver differential output with a 60- Ω load (two 120- Ω termination resistors in parallel), and the differential output must be greater than 1.5 V. The SN55HVD233-SP is specified to meet the 1.5-V requirement with a 60- Ω load, and additionally specified with a differential output voltage minimum of 1.2 V across a common mode range of -2 to 7 V through a 330- Ω coupling network. This network represents the bus loading of 120 SN55HVD233-SP transceivers based on their minimum differential input resistance of 40 k Ω . Therefore, the SN55HVD233-SP supports up to 120 transceivers on a single bus segment with margin to the 1.2-V minimum differential input voltage requirement at each node. For CAN network design, margin must be given for signal loss across the system and cabling, parasitic loadings, network imbalances, ground offsets, and signal integrity; thus, a practical maximum number of nodes may be lower. Bus length may also be extended beyond the original ISO11898 standard of 40 m by careful system design and data rate tradeoffs. For example, CANopen network design guidelines allow the network to be up to 1 km with changes in the termination resistance, cabling, less than 64 nodes, and significantly lowered data rate.

This flexibility in CAN network design is one of the key strengths of the various extensions and additional standards that have been built on the original ISO11898 CAN standard. Using this flexibility requires good network design.

12.1.2 CAN Termination

The ISO11898 standard specifies the interconnect to be a twisted pair cable (shielded or unshielded) with 120- Ω characteristic impedance (Z_0). Use resistors equal to the characteristic impedance of the line to terminate both ends of the cable to prevent signal reflections. Keep unterminated drop lines (stubs) connecting nodes to the bus as short as possible to minimize signal reflections. The termination may be on the cable or in a node, but if nodes may be removed from the bus, the termination must be carefully placed so that it is not removed from the bus.

Layout Guidelines (continued)

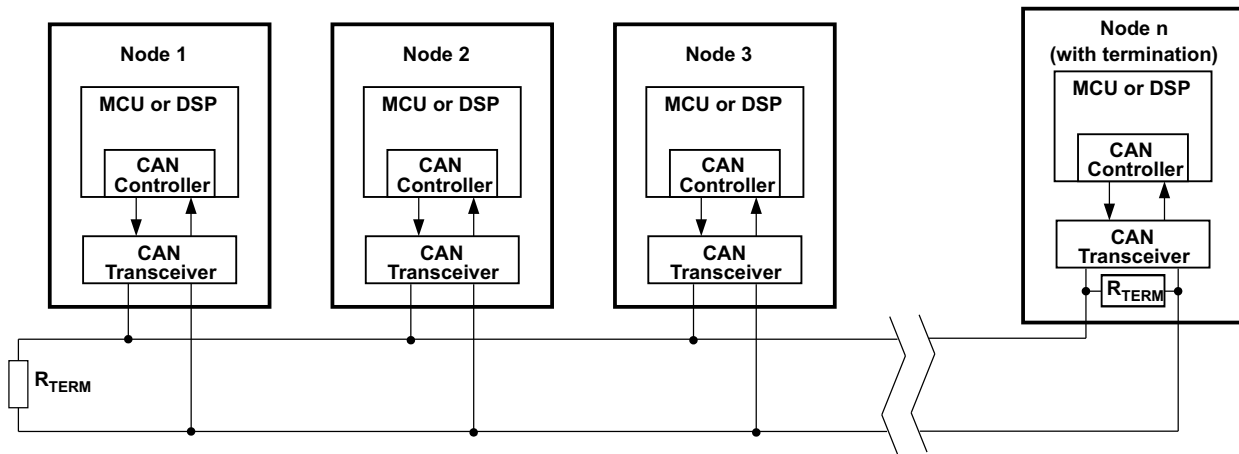

Figure 33. Typical CAN Bus

Termination is typically a 120-Ω resistor at each end of the bus. If filtering and stabilization of the common mode voltage of the bus is desired, then the user may use split termination (see Figure 34). Split termination uses two 60-Ω resistors with a capacitor in the middle of these resistors to ground. Split termination improves the electromagnetic emissions behavior of the network by eliminating fluctuations in the bus common mode voltages at the start and end of message transmissions.

Take care with the power ratings of the termination resistors used, especially for the worst-case condition (if a system power supply is shorted across the termination resistance to ground). In most cases, under the worst-case condition, much higher current passes through the termination resistance than the CAN transceiver's current limit.

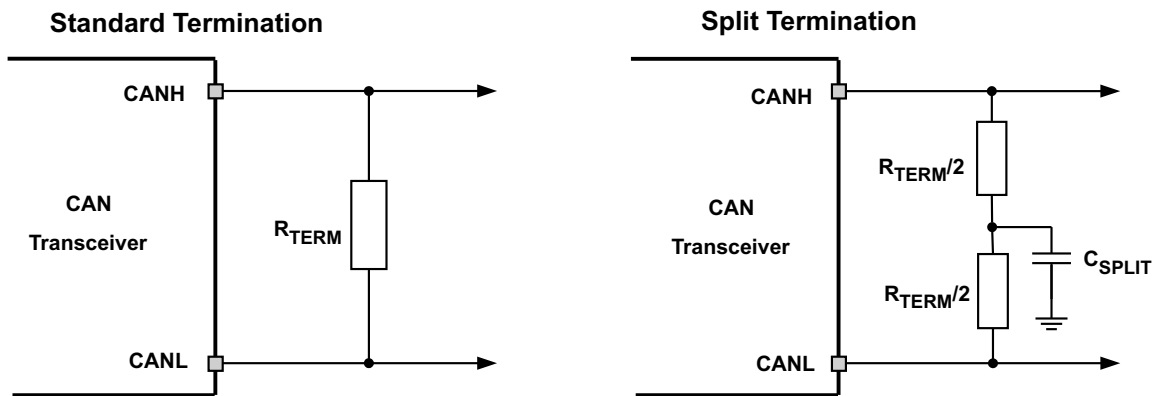

Figure 34. CAN Bus Termination Concepts

12.2 Layout Example

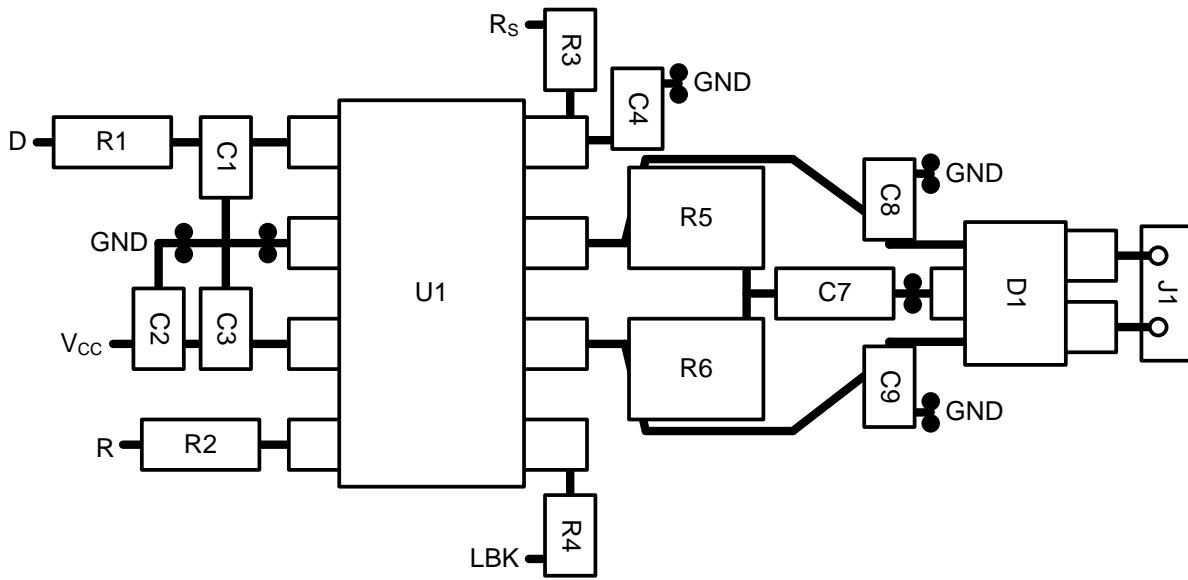

Figure 35. Board Layout Example

13 Device and Documentation Support

13.1 Receiving Notification of Documentation Updates

To receive notification of documentation updates, navigate to the device product folder on ti.com. In the upper right corner, click on *Alert me* to register and receive a weekly digest of any product information that has changed. For change details, review the revision history included in any revised document.

13.2 Community Resources

The following links connect to TI community resources. Linked contents are provided "AS IS" by the respective contributors. They do not constitute TI specifications and do not necessarily reflect TI's views; see TI's [Terms of Use](#).

TI E2E™ Online Community *TI's Engineer-to-Engineer (E2E) Community*. Created to foster collaboration among engineers. At e2e.ti.com, you can ask questions, share knowledge, explore ideas and help solve problems with fellow engineers.

Design Support *TI's Design Support* Quickly find helpful E2E forums along with design support tools and contact information for technical support.

13.3 Trademarks

E2E is a trademark of Texas Instruments.
All other trademarks are the property of their respective owners.

13.4 Electrostatic Discharge Caution



These devices have limited built-in ESD protection. The leads should be shorted together or the device placed in conductive foam during storage or handling to prevent electrostatic damage to the MOS gates.

13.5 Glossary



[SLYZ022](#) — *TI Glossary*.

This glossary lists and explains terms, acronyms, and definitions.

14 Mechanical, Packaging, and Orderable Information

The following pages include mechanical, packaging, and orderable information. This information is the most current data available for the designated devices. This data is subject to change without notice and revision of this document. For browser-based versions of this data sheet, refer to the left-hand navigation.

PACKAGING INFORMATION

Orderable Device	Status (1)	Package Type	Package Drawing	Pins	Package Qty	Eco Plan (2)	Lead finish/ Ball material (6)	MSL Peak Temp (3)	Op Temp (°C)	Device Marking (4/5)	Samples
5962L1420901VXC	ACTIVE	CFP	HKX	8	1	RoHS & Green	NIAU	N / A for Pkg Type	-55 to 125	L1420901VXC HVD233-SP	
HVD233HKX/EM	ACTIVE	CFP	HKX	8	1	RoHS & Green	NIAU	N / A for Pkg Type	25 to 25	HVD233HKX/EM EVAL ONLY	

(1) The marketing status values are defined as follows:

ACTIVE: Product device recommended for new designs.

LIFEBUY: TI has announced that the device will be discontinued, and a lifetime-buy period is in effect.

NRND: Not recommended for new designs. Device is in production to support existing customers, but TI does not recommend using this part in a new design.

PREVIEW: Device has been announced but is not in production. Samples may or may not be available.

OBsolete: TI has discontinued the production of the device.

(2) **RoHS:** TI defines "RoHS" to mean semiconductor products that are compliant with the current EU RoHS requirements for all 10 RoHS substances, including the requirement that RoHS substance do not exceed 0.1% by weight in homogeneous materials. Where designed to be soldered at high temperatures, "RoHS" products are suitable for use in specified lead-free processes. TI may reference these types of products as "Pb-Free".

RoHS Exempt: TI defines "RoHS Exempt" to mean products that contain lead but are compliant with EU RoHS pursuant to a specific EU RoHS exemption.

Green: TI defines "Green" to mean the content of Chlorine (Cl) and Bromine (Br) based flame retardants meet JS709B low halogen requirements of <=1000ppm threshold. Antimony trioxide based flame retardants must also meet the <=1000ppm threshold requirement.

(3) MSL, Peak Temp. - The Moisture Sensitivity Level rating according to the JEDEC industry standard classifications, and peak solder temperature.

(4) There may be additional marking, which relates to the logo, the lot trace code information, or the environmental category on the device.

(5) Multiple Device Markings will be inside parentheses. Only one Device Marking contained in parentheses and separated by a "~" will appear on a device. If a line is indented then it is a continuation of the previous line and the two combined represent the entire Device Marking for that device.

(6) Lead finish/Ball material - Orderable Devices may have multiple material finish options. Finish options are separated by a vertical ruled line. Lead finish/Ball material values may wrap to two lines if the finish value exceeds the maximum column width.

Important Information and Disclaimer:The information provided on this page represents TI's knowledge and belief as of the date that it is provided. TI bases its knowledge and belief on information provided by third parties, and makes no representation or warranty as to the accuracy of such information. Efforts are underway to better integrate information from third parties. TI has taken and continues to take reasonable steps to provide representative and accurate information but may not have conducted destructive testing or chemical analysis on incoming materials and chemicals. TI and TI suppliers consider certain information to be proprietary, and thus CAS numbers and other limited information may not be available for release.

In no event shall TI's liability arising out of such information exceed the total purchase price of the TI part(s) at issue in this document sold by TI to Customer on an annual basis.

OTHER QUALIFIED VERSIONS OF SN55HVD233-SP :

- Catalog : [SN55HVD233-SEP](#)

NOTE: Qualified Version Definitions:

- Catalog - TI's standard catalog product

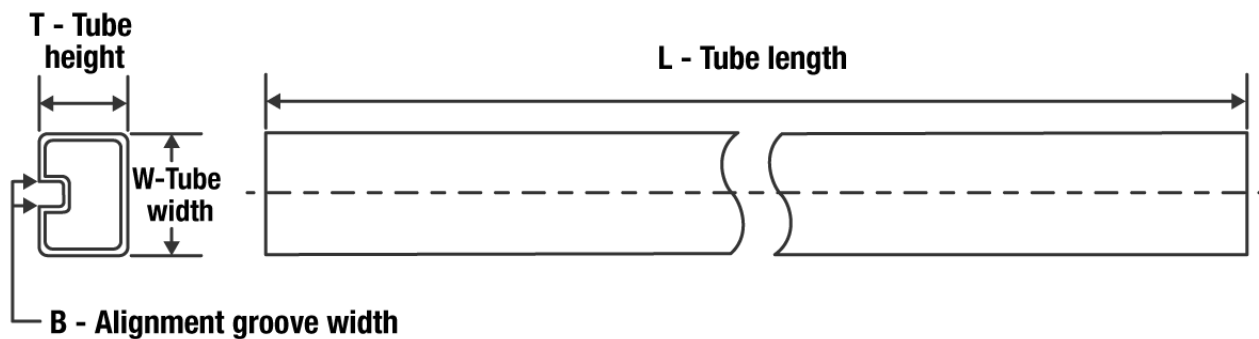
TUBE

*All dimensions are nominal

Device	Package Name	Package Type	Pins	SPQ	L (mm)	W (mm)	T (μm)	B (mm)
5962L1420901VXC	HKX	CFP (HSL)	8	1	506.98	26.16	6220	NA
HVD233HKX/EM	HKX	CFP (HSL)	8	1	506.98	26.16	6220	NA

HKX0008A



PACKAGE OUTLINE
CFP - 2.785 mm max height

CERAMIC FLATPACK

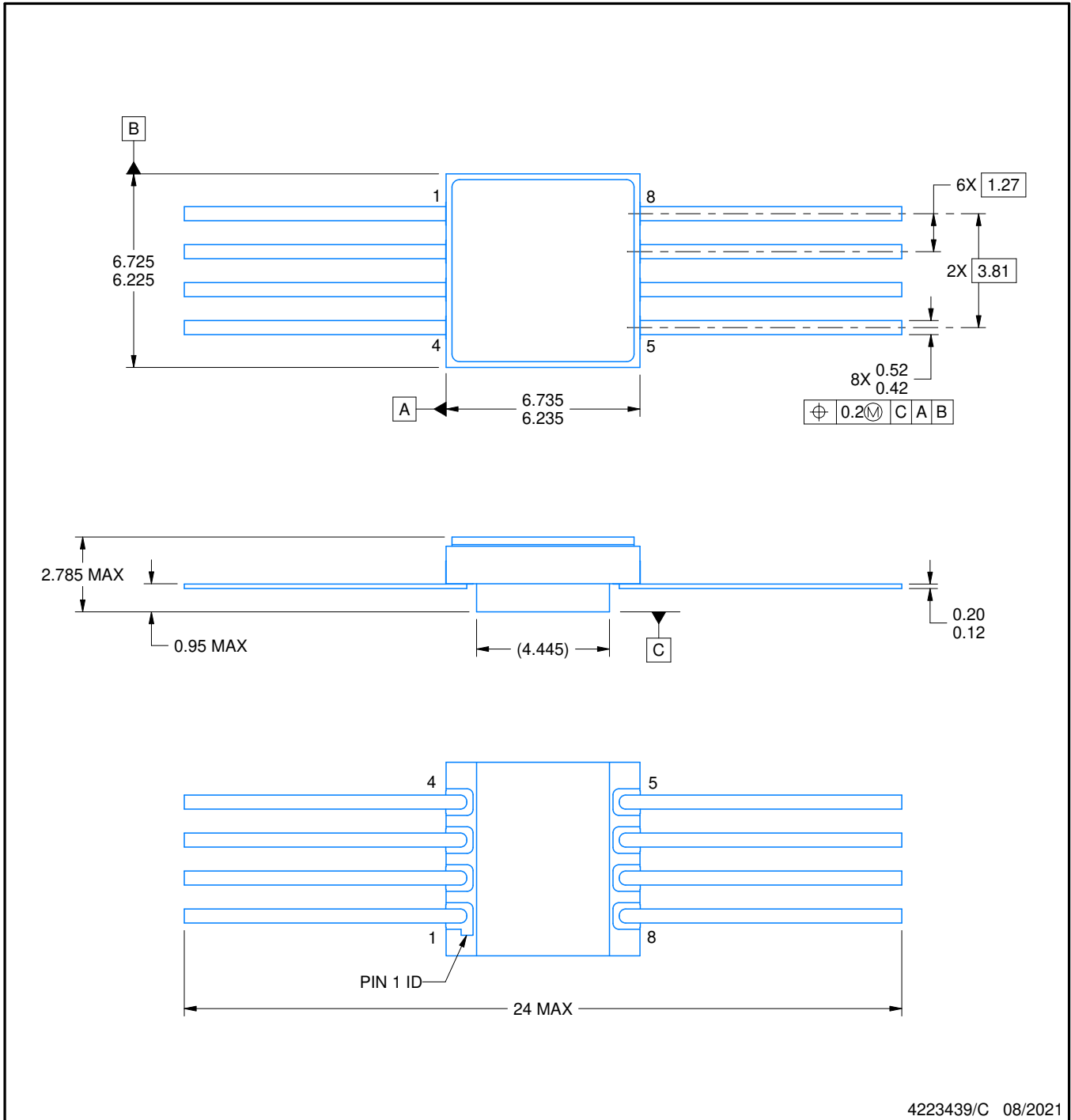

4223439/C 08/2021

NOTES:

1. All linear dimensions are in millimeters. Any dimensions in parenthesis are for reference only. Dimensioning and tolerancing per ASME Y14.5M.
2. This drawing is subject to change without notice.
3. This package is hermetically sealed with a metal lid.
4. The leads are gold plated.



PACKAGE OUTLINE

HKU0010A

CFP - 2.63mm max height

CERAMIC DUAL FLATPACK

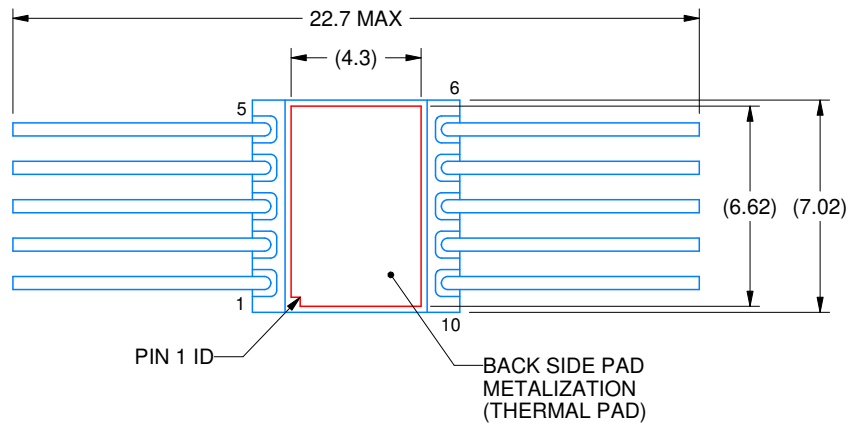
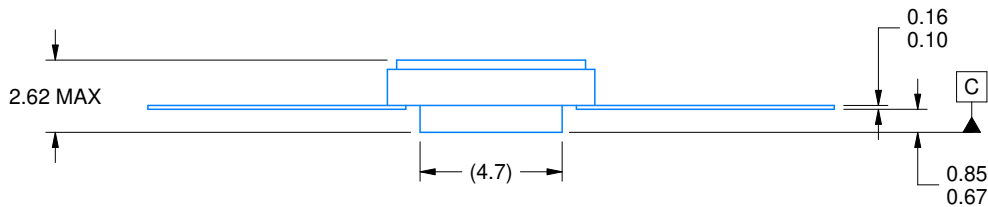
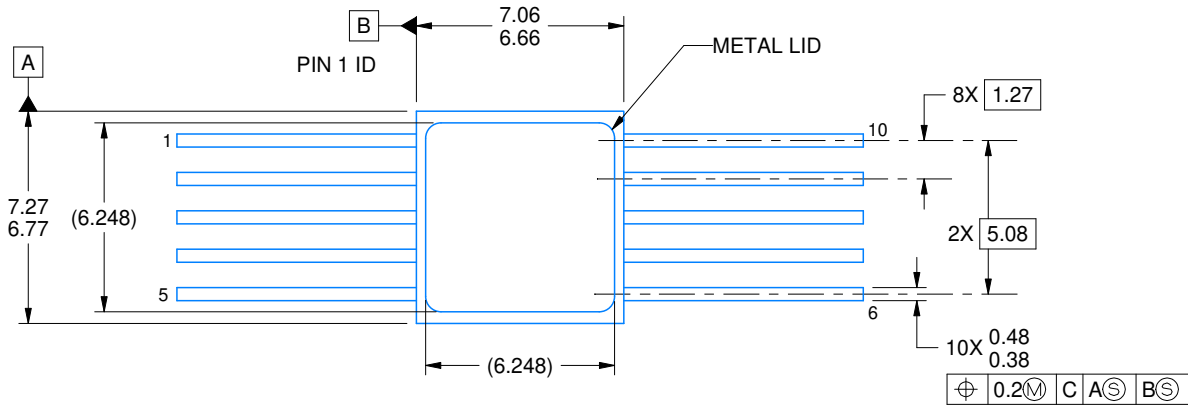

4226200/A 09/2020

NOTES:

1. All linear dimensions are in millimeters. Any dimensions in parenthesis are for reference only. Dimensioning and tolerancing per ASME Y14.5M.
2. This drawing is subject to change without notice.
3. This package is hermetically sealed with a metal lid.
4. The terminals are gold plated.
5. This drawing does not comply with MIL STD 1835. Do not use this package for compliant product.
6. Metal lid is connected to back side pad metalization.

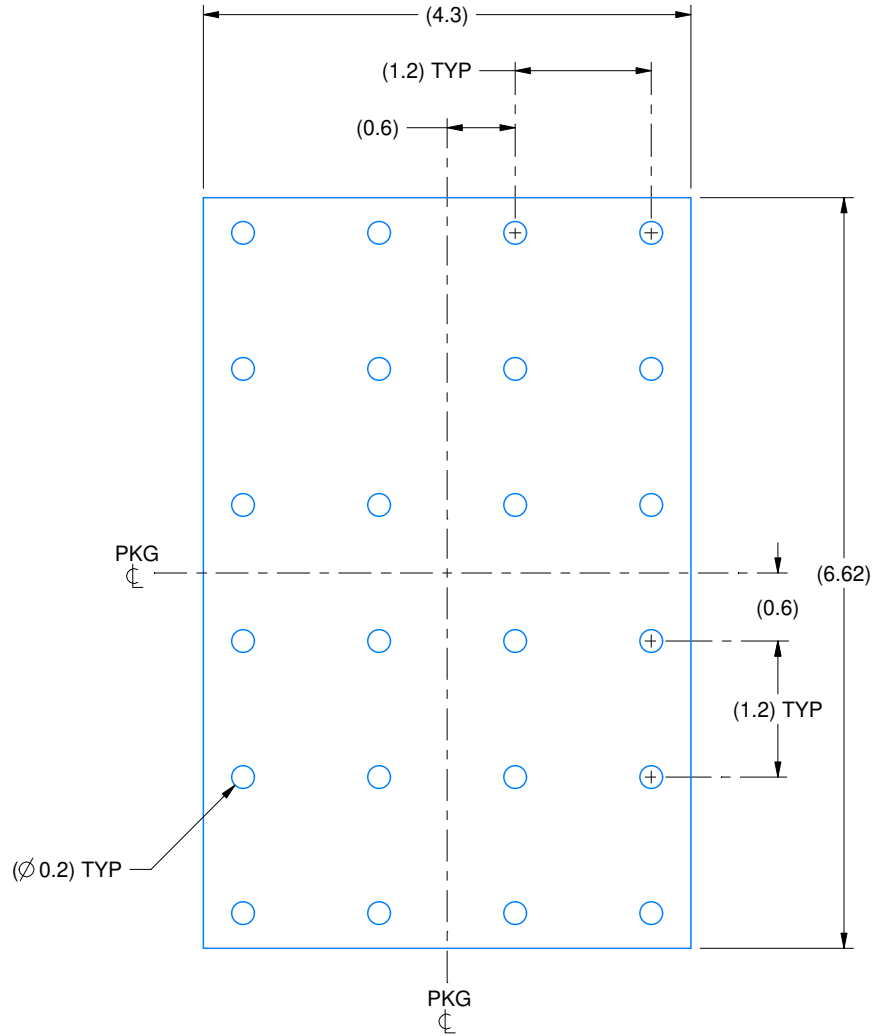

HEATSINK LAND PATTERN EXAMPLE
EXPOSED METAL SHOWN
SCALE:15X

IMPORTANT NOTICE AND DISCLAIMER

TI PROVIDES TECHNICAL AND RELIABILITY DATA (INCLUDING DATA SHEETS), DESIGN RESOURCES (INCLUDING REFERENCE DESIGNS), APPLICATION OR OTHER DESIGN ADVICE, WEB TOOLS, SAFETY INFORMATION, AND OTHER RESOURCES "AS IS" AND WITH ALL FAULTS, AND DISCLAIMS ALL WARRANTIES, EXPRESS AND IMPLIED, INCLUDING WITHOUT LIMITATION ANY IMPLIED WARRANTIES OF MERCHANTABILITY, FITNESS FOR A PARTICULAR PURPOSE OR NON-INFRINGEMENT OF THIRD PARTY INTELLECTUAL PROPERTY RIGHTS.

These resources are intended for skilled developers designing with TI products. You are solely responsible for (1) selecting the appropriate TI products for your application, (2) designing, validating and testing your application, and (3) ensuring your application meets applicable standards, and any other safety, security, regulatory or other requirements.

These resources are subject to change without notice. TI grants you permission to use these resources only for development of an application that uses the TI products described in the resource. Other reproduction and display of these resources is prohibited. No license is granted to any other TI intellectual property right or to any third party intellectual property right. TI disclaims responsibility for, and you will fully indemnify TI and its representatives against, any claims, damages, costs, losses, and liabilities arising out of your use of these resources.

TI's products are provided subject to [TI's Terms of Sale](#) or other applicable terms available either on ti.com or provided in conjunction with such TI products. TI's provision of these resources does not expand or otherwise alter TI's applicable warranties or warranty disclaimers for TI products.

TI objects to and rejects any additional or different terms you may have proposed.

Mailing Address: Texas Instruments, Post Office Box 655303, Dallas, Texas 75265
Copyright © 2022, Texas Instruments Incorporated