

REVISIONS					
P	LTR	DESCRIPTION	DATE	DWN	APVD
	A1	REVISED PER ECO-20-005258	15APR2020	SR	JB

SPECIFICATIONS

MECHANICAL LIFE: 30,000 MAKE-AND-BREAK CYCLES.

CONTACT RESISTANCE: 20 mΩ MAX. INITIAL @ 2-4VDC
100mA FOR BOTH SILVER AND GOLD
PLATED CONTACTS.

CONTACT RATING: GOLD-0.4 VA MAX @ 20 V MAX (AC OR DC)
SILVER-3 A @ 120 VAC OR 28 VDC
1 A @ 250 VAC

INSULATION RESISTANCE: 1,000 MΩ MIN.

DIELECTRIC STRENGTH: 1,000 Vrms @SEA LEVEL.

OPERATING TEMPERATURE: -30°C TO 85°C.

SEALED PER: IP67

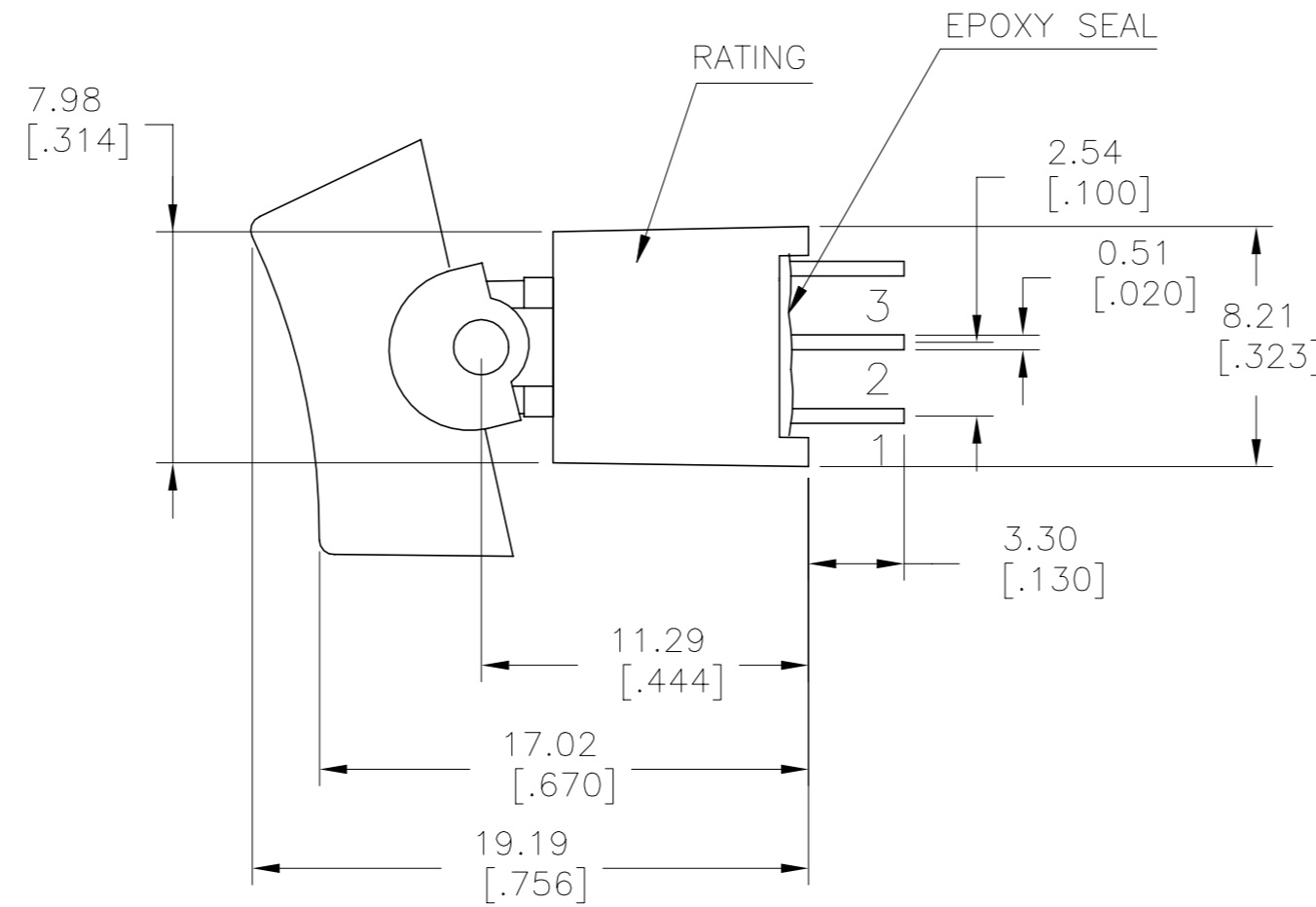
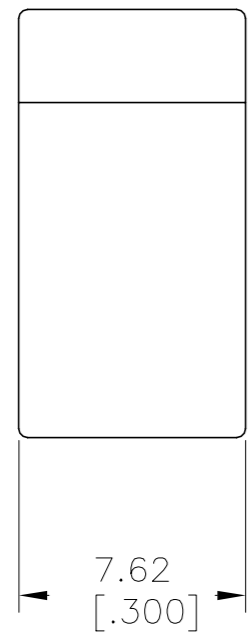

SILVER	2-1,5-4	2-3,5-6	ON-ON	V-BRACKET	VERTICAL	2	2	RAD1R102VS2QES	2267088-8
GOLD	2-1	2-3	ON-ON	V-BRACKET	VERTICAL	1	2	RAS1R102VS2RES	2267088-7
GOLD	2-1,5-4	2-3,5-6	ON-ON	PC THROUGH HOLE	VERTICAL RIGHT ANGLE	2	2	RAD1R102M7RES	2267088-6
GOLD	2-1	2-3	ON-ON	PC THROUGH HOLE	VERTICAL RIGHT ANGLE	1	2	RAS1R102M7RES	2267088-5
SILVER	2-1,5-4	2-3,5-6	ON-ON	PC THROUGH HOLE	RIGHT ANGLE	2	2	RAD1R102M6QES	2267088-4
SILVER	2-1	2-3	ON-ON	PC THROUGH HOLE	RIGHT ANGLE	1	2	RAS1R202M6QES	2267088-3
SILVER	2-1,5-4	2-3,5-6	ON-ON	PC THROUGH HOLE	VERTICAL	2	2	RAD1R102M2QES	2267088-2
GOLD	2-1	2-3	ON-ON	PC THROUGH HOLE	VERTICAL	1	2	RAS1R102M2RES	2267088-1
CONTACT MATERIAL	POS 2	POS 1	FUNCTION	TERMINATION	MOUNT ANGLE	POLES	THROWS	DESCRIPTIVE PN	TE PN

THIS DRAWING IS A CONTROLLED DOCUMENT.

DIMENSIONS: mm [INCHES]

TOLERANCES UNLESS OTHERWISE SPECIFIED:

0 PLC	± -
1 PLC	± 0.38[.015]
2 PLC	± 0.25[.010]
3 PLC	± -
4 PLC	± -
ANGLES	± 5°

MATERIAL: - FINISH: -

APPROVALS:

DWN	10JUL2014	NAGALAKSHMI K
CHK	10JUL2014	HILL, RYAN
APVD	10JUL2014	HILL, RYAN

PRODUCT SPEC: - APPLICATION SPEC: -

WEIGHT: -

CUSTOMER DRAWING

TE Connectivity Ltd. SUBMINIATURE ROCKER SWITCHES

SIZE: A2 CAGE CODE: 00779 DRAWING NO: C=2267088 RESTRICTED TO: -

SCALE: 3:1 SHEET: 1 of 5 REV: A1

REVISIONS					
P	LTR	DESCRIPTION	DATE	DWN	APVD
-	-	SEE SHEET 1	-	-	-

ACTUATOR OPTIONS

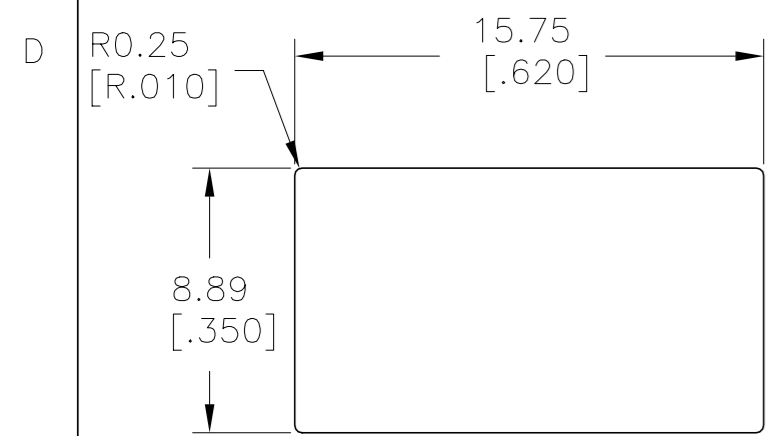

PANEL MOUNTING

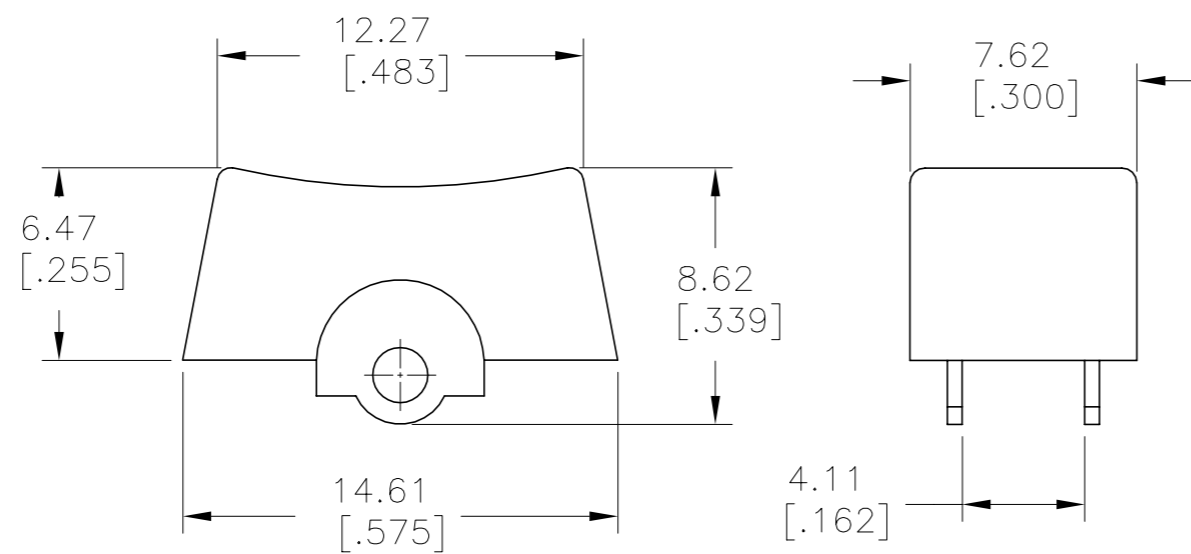

R1

WIDE ACTUATOR

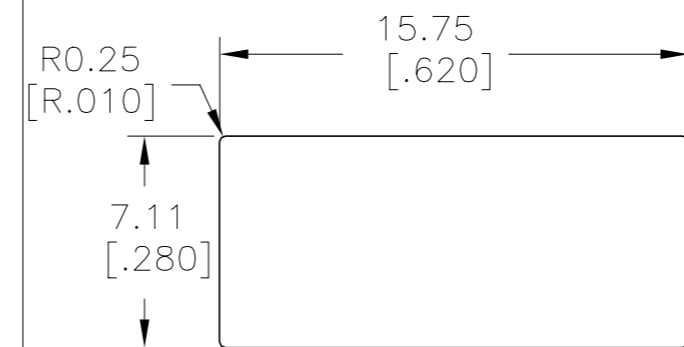

PANEL MOUNTING

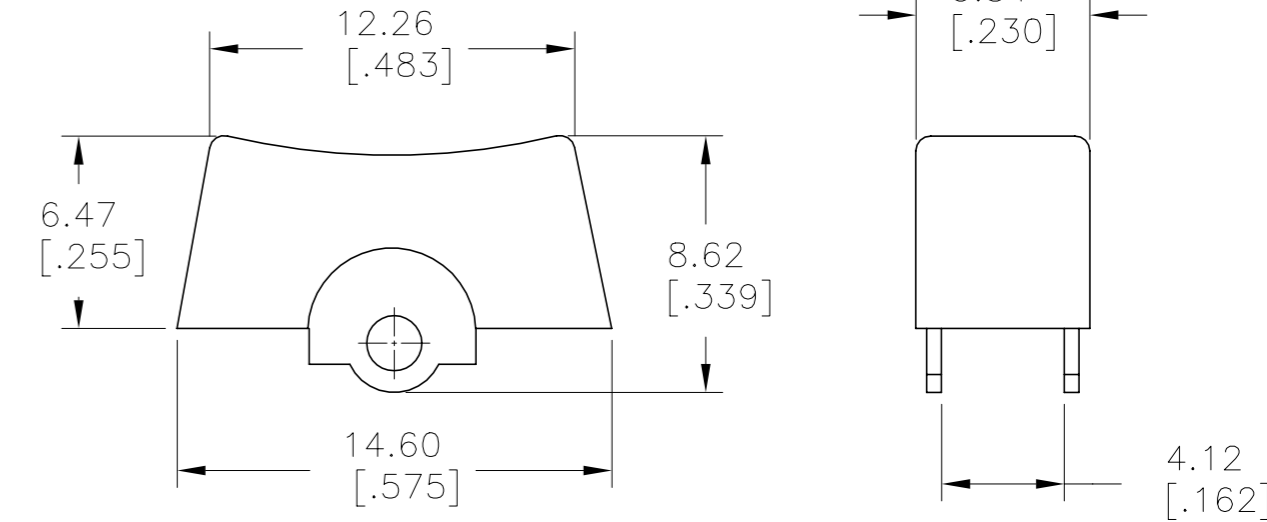

R2

NARROW ACTUATOR

TERMINATION OPTIONS

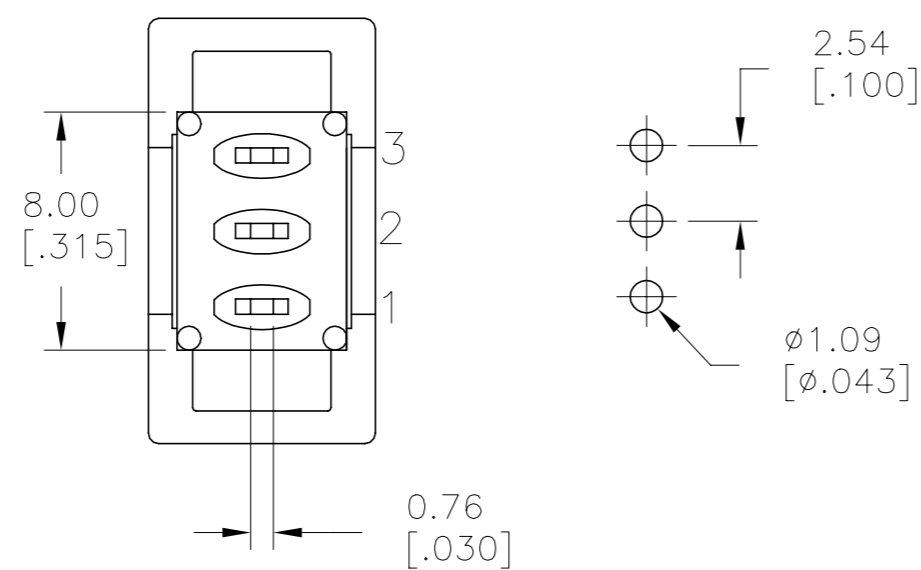
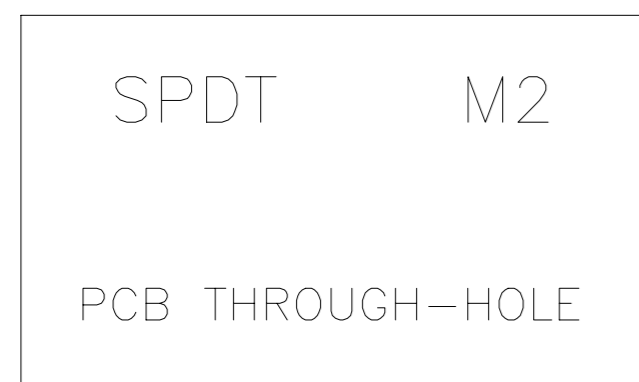

P.C. MOUNTING

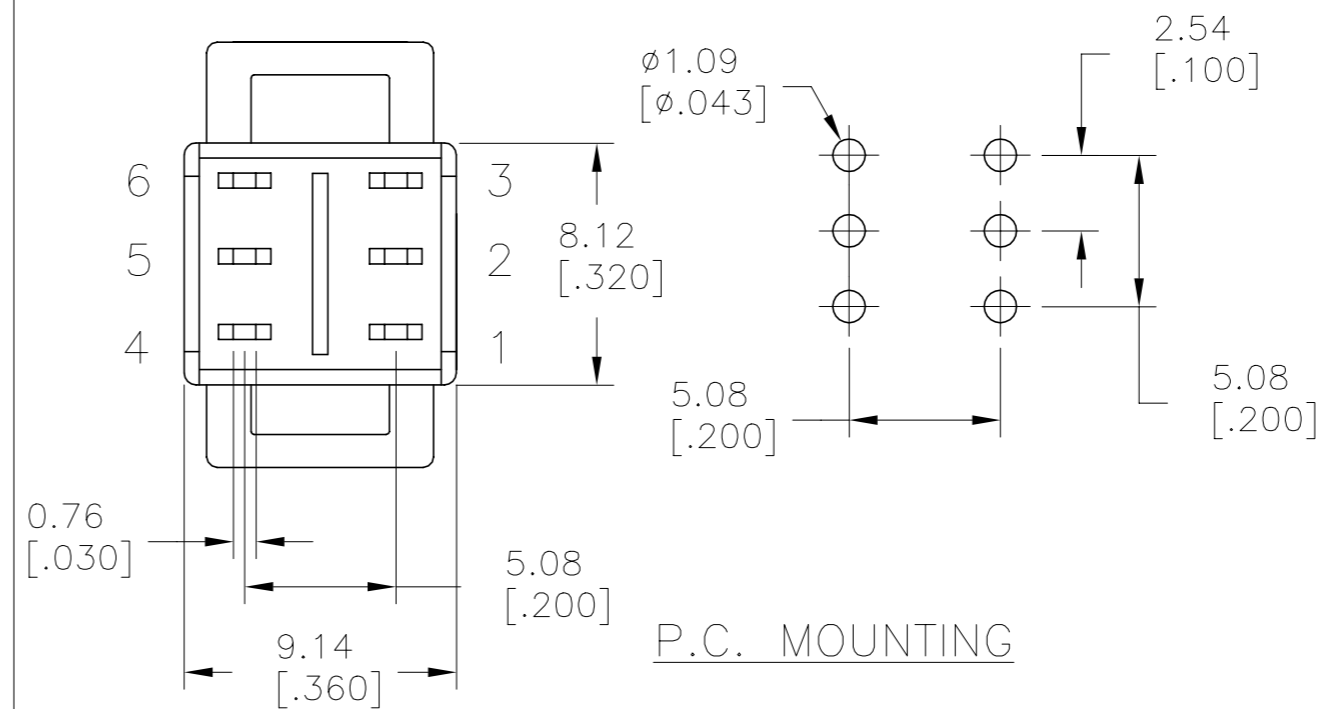

P.C. MOUNTING

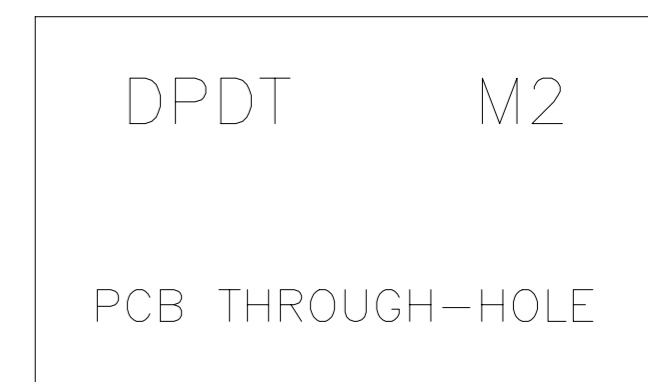

LAYOUT FOR PN 2267088-1 & 2

THIS DRAWING IS A CONTROLLED DOCUMENT.		DWN NAGALAKSHMI K 10JUL2014	TE Connectivity Ltd.	
DIMENSIONS: mm [INCHES]		CHK HILL, RYAN 10JUL2014		
TOLERANCES UNLESS OTHERWISE SPECIFIED:		APVD HILL, RYAN 10JUL2014		RESTRICTED TO
0 PLC ± - 1 PLC ± 0.38[.015] 2 PLC ± 0.25[.010] 3 PLC ± - 4 PLC ± - ANGLES ± 5°		PRODUCT SPEC		SIZE A2
MATERIAL		APPLICATION SPEC		CAGE CODE 00779
		WEIGHT		DRAWING NO C=2267088
		CUSTOMER DRAWING		SCALE 3:1
				SHEET 2 of 5
				REV A1

REVISIONS					
P	LTR	DESCRIPTION	DATE	DWN	APVD
-	-	SEE SHEET 1	-	-	-

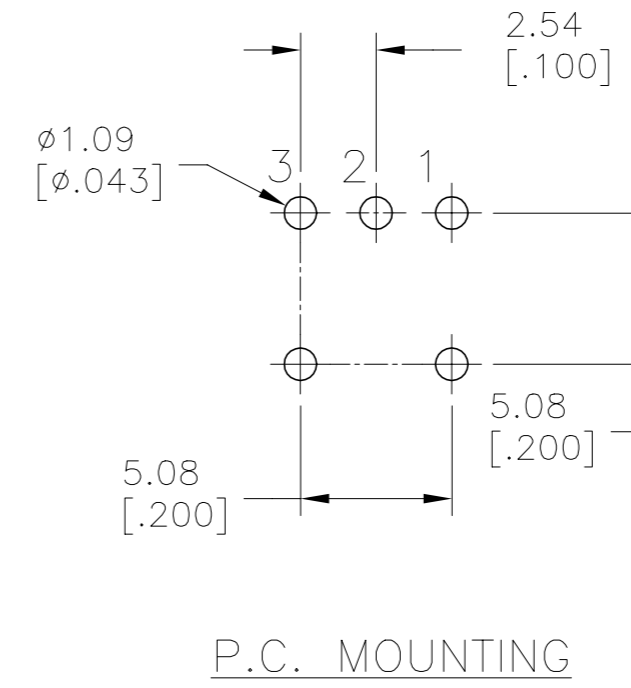
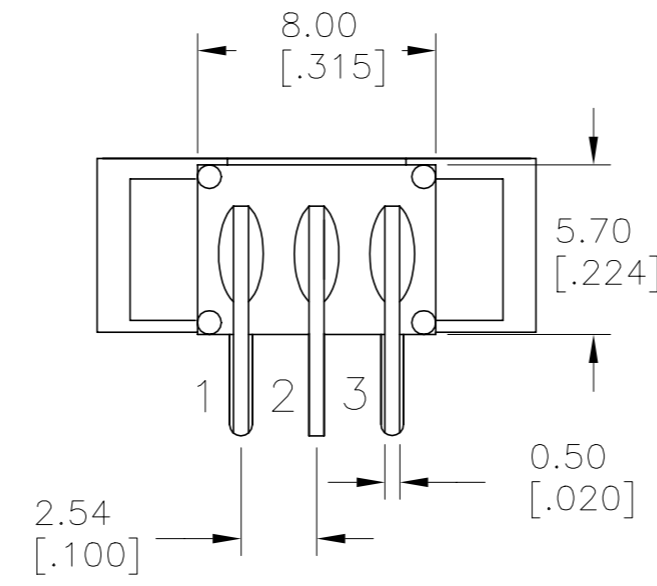
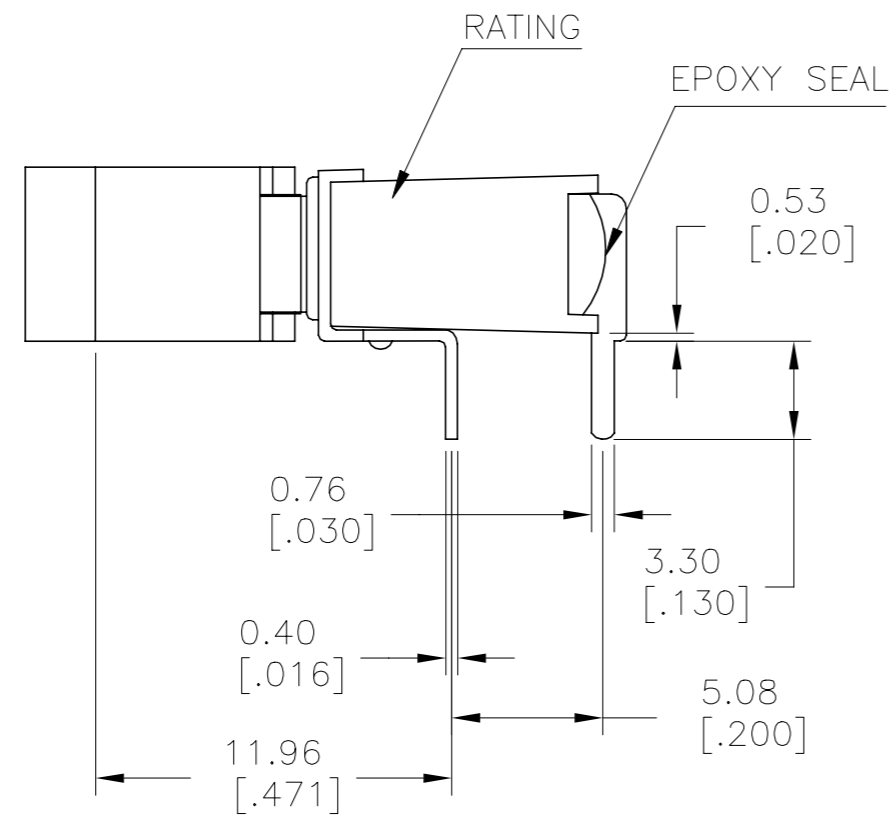
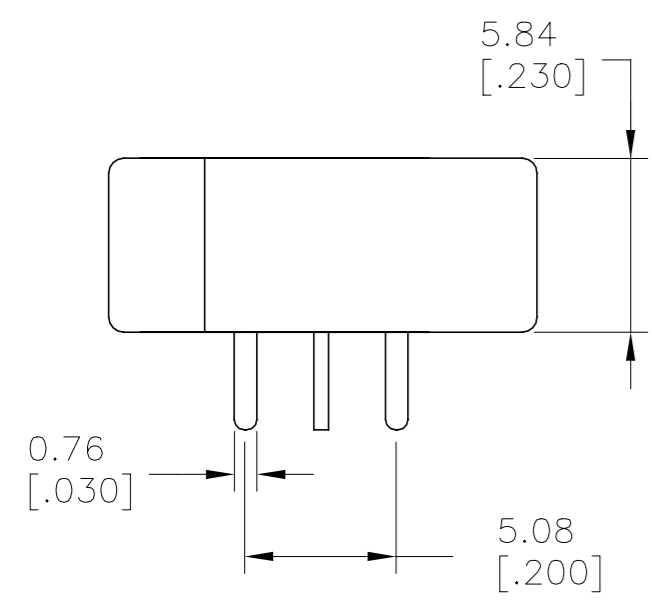

SPDT M6
RIGHT ANGLE

P.C. MOUNTING

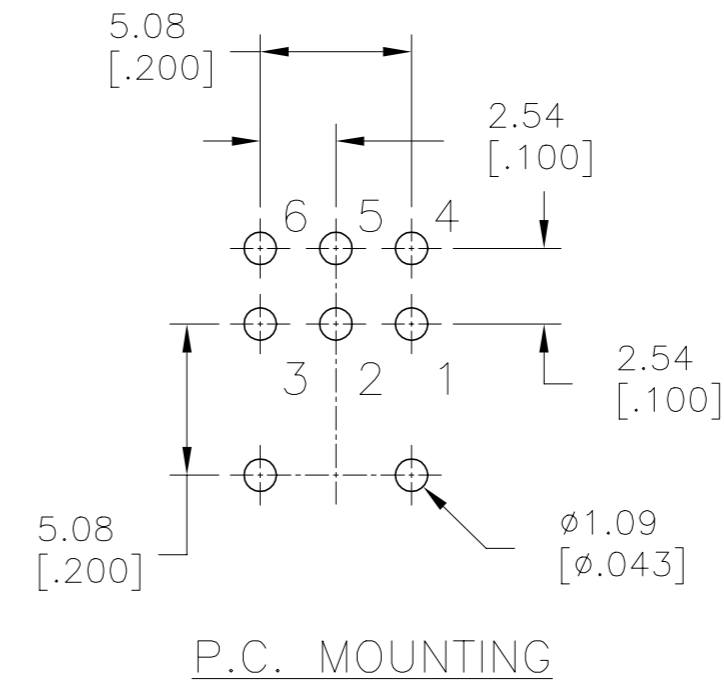
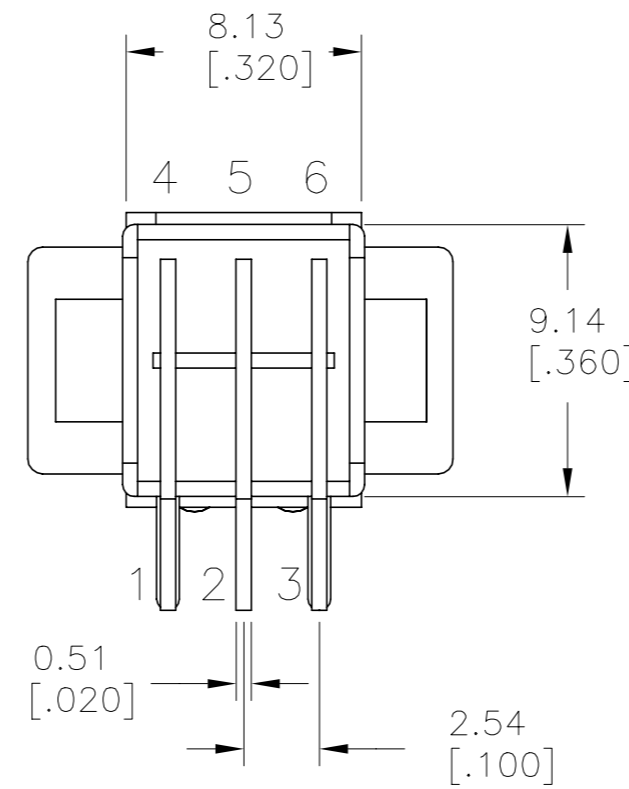
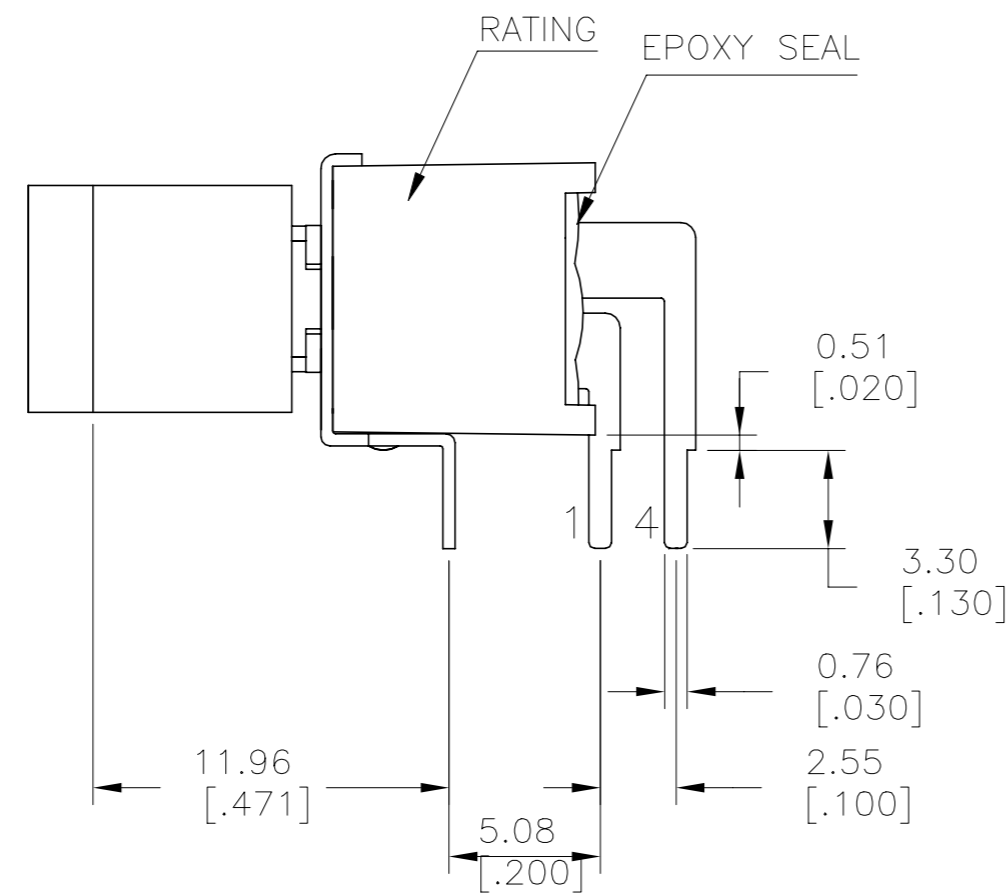
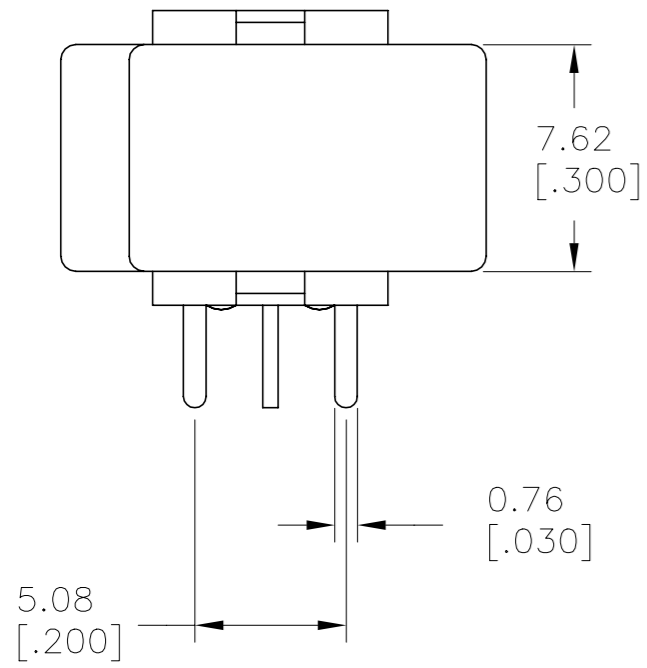

DPDT M6
RIGHT ANGLE

P.C. MOUNTING

LAYOUT FOR PN 2267088-3 & 4

THIS DRAWING IS A CONTROLLED DOCUMENT.		DWN NAGALAKSHMI K 10JUL2014	TE Connectivity Ltd.	
DIMENSIONS: mm [INCHES]		CHK HILL, RYAN 10JUL2014		
TOLERANCES UNLESS OTHERWISE SPECIFIED:		APVD HILL, RYAN 10JUL2014	NAME SUBMINIATURE ROCKER SWITCHES	
0 PLC ± -		PRODUCT SPEC	SIZE A2	
1 PLC ± 0.38[015]		APPLICATION SPEC	CAGE CODE 00779	DRAWING NO C=2267088
2 PLC ± 0.25[010]		WEIGHT	RESTRICTED TO	
3 PLC ± -			SCALE 3:1	SHEET 3 of 5
4 PLC ± -			REV A1	
ANGLES ± 5°				
MATERIAL			CUSTOMER DRAWING	
FINISH				

REVISIONS					
P	LTR	DESCRIPTION	DATE	DWN	APVD
-	-	SEE SHEET 1	-	-	-

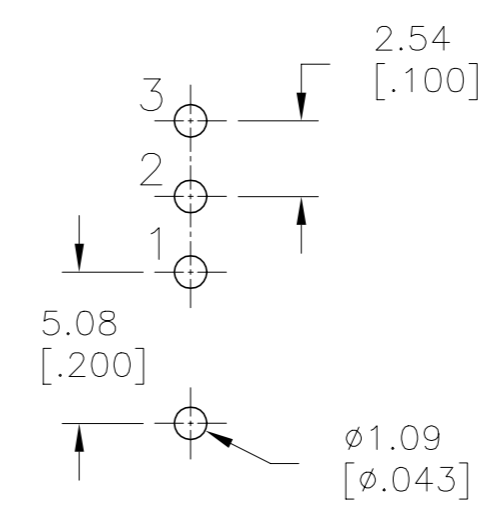
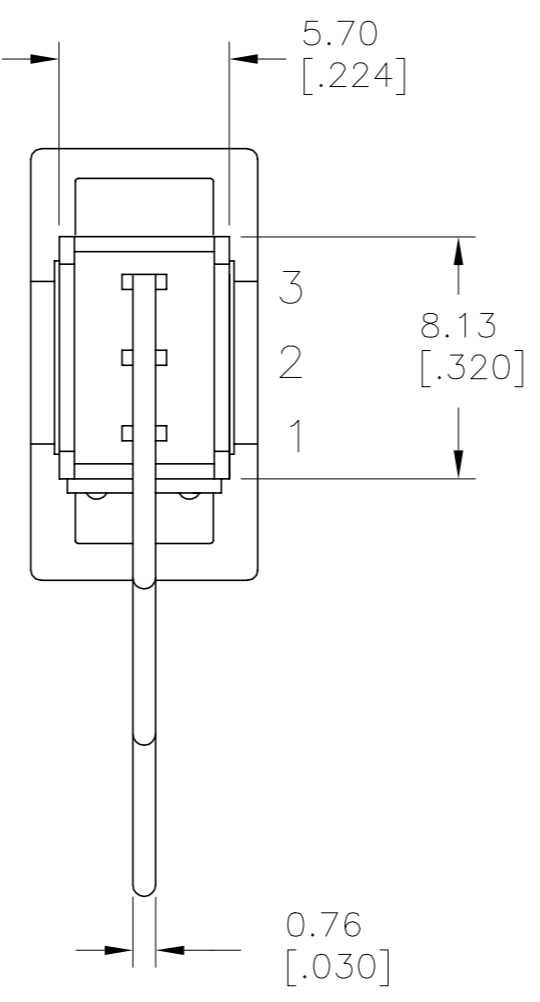
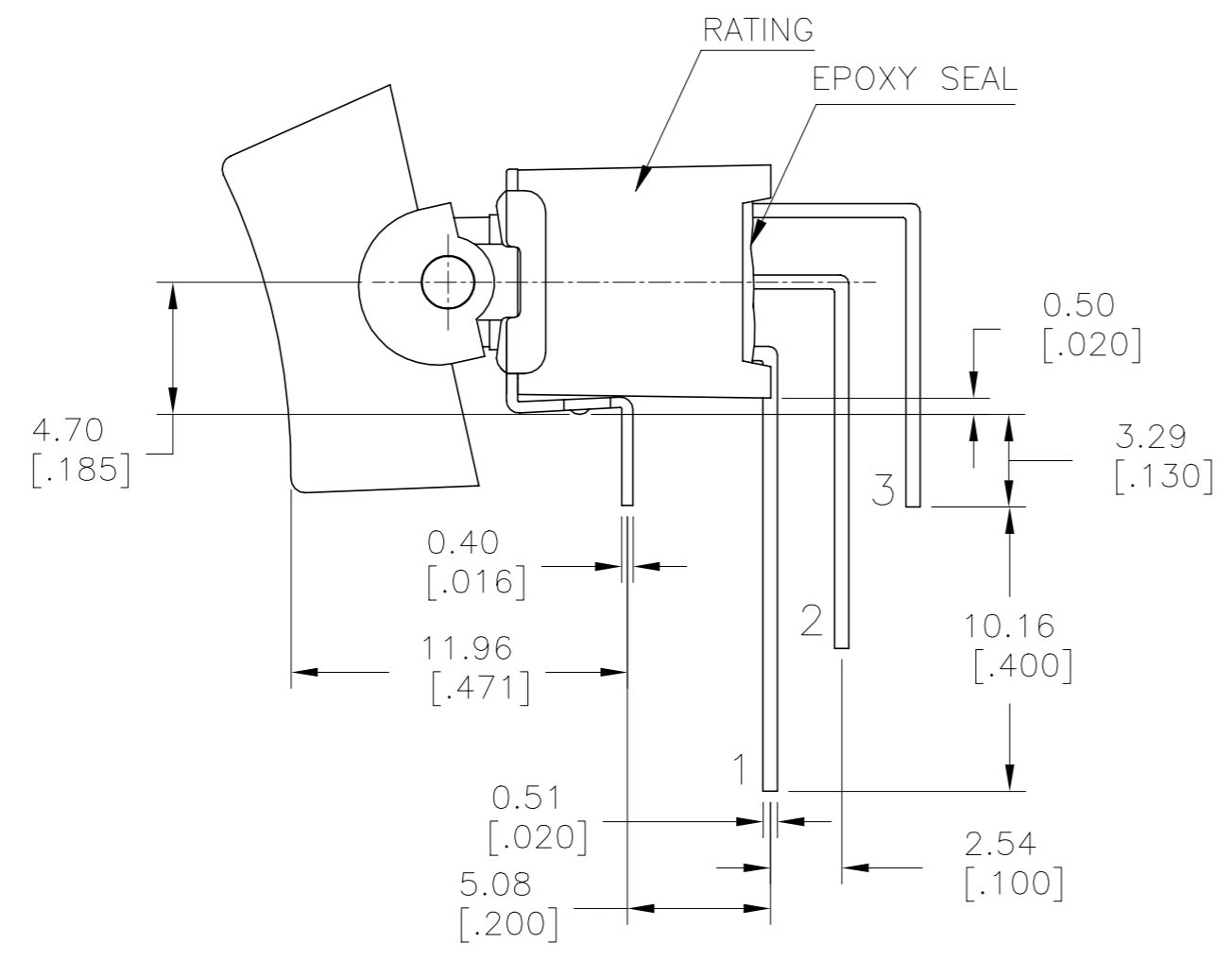
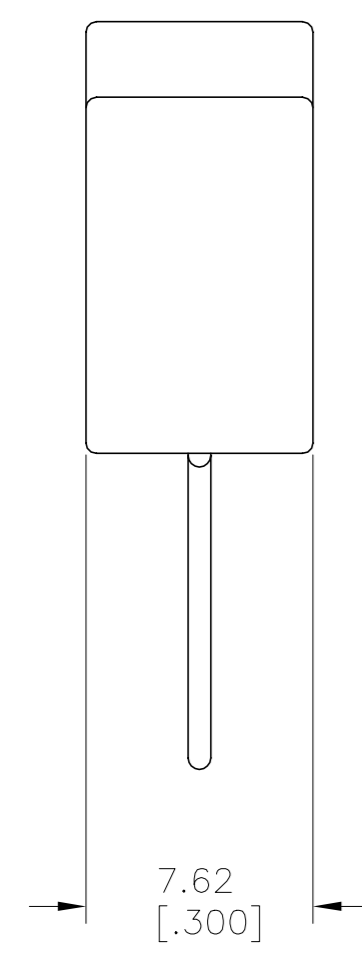

SPDT M7
VERTICAL
RIGHT ANGLE

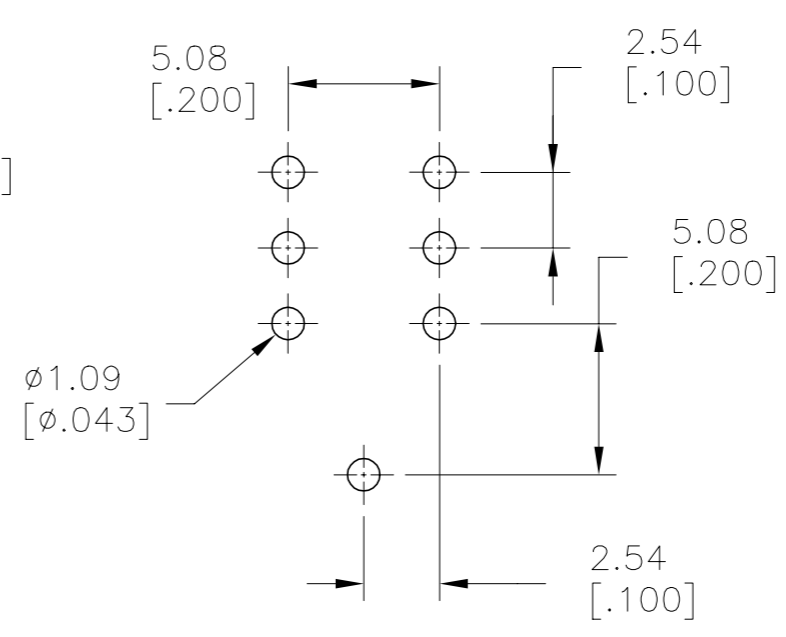
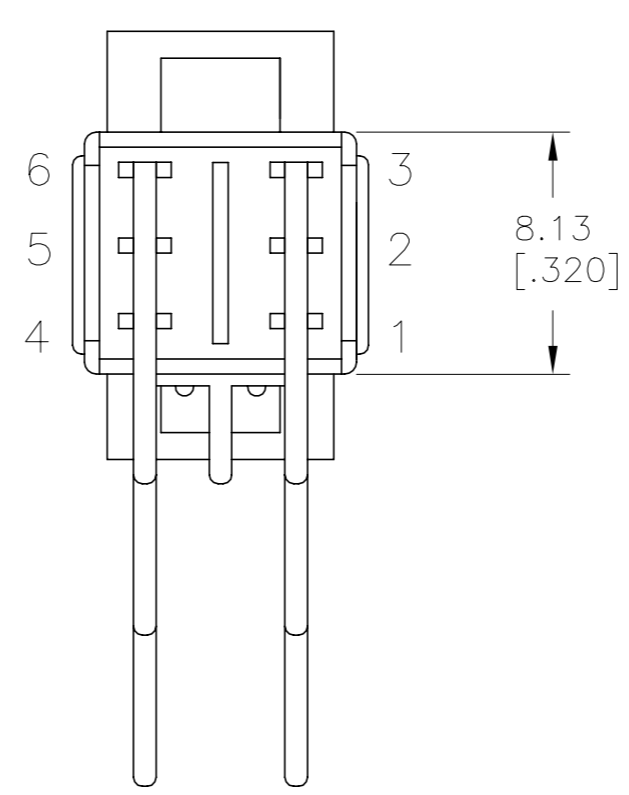
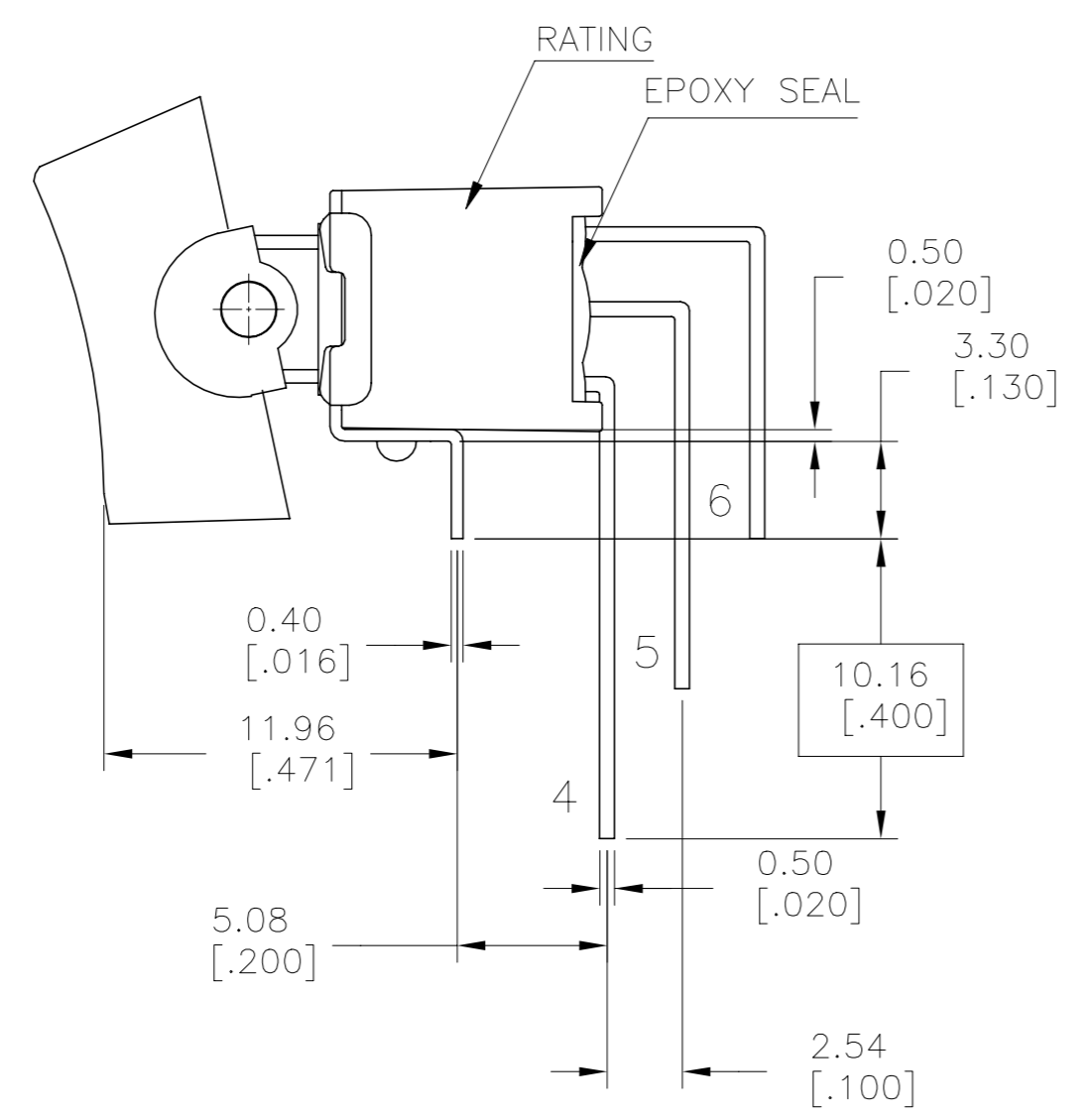
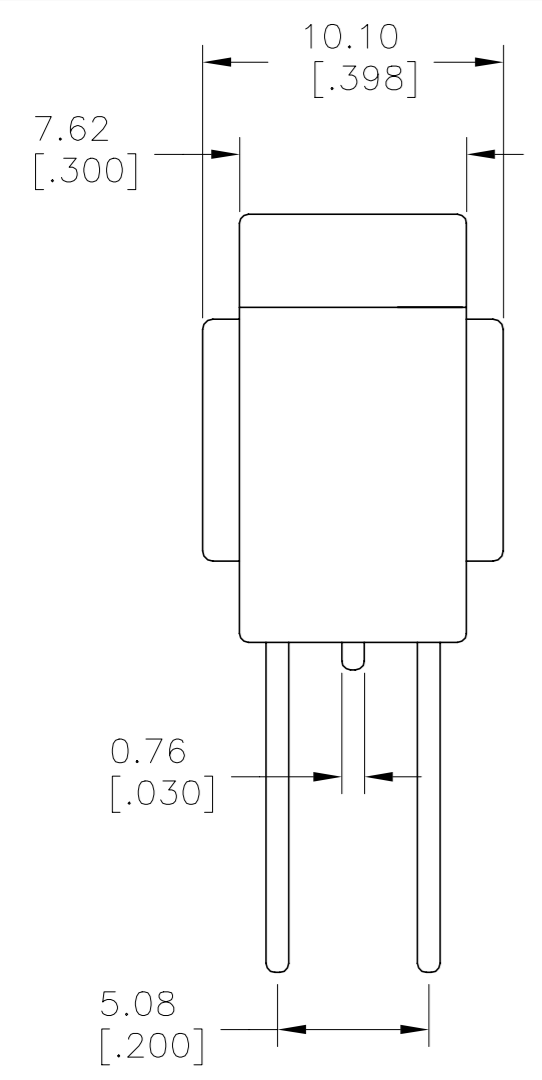

DPDT M7
VERTICAL
RIGHT ANGLE

LAYOUT FOR PN 2267088-5 & 6

THIS DRAWING IS A CONTROLLED DOCUMENT.		DWN NAGALAKSHMI K	10JUL2014	TE Connectivity Ltd.	
DIMENSIONS: mm [INCHES]		CHK HILL, RYAN	10JUL2014		
TOLERANCES UNLESS OTHERWISE SPECIFIED:		APVD HILL, RYAN	10JUL2014	NAME SUBMINIATURE ROCKER SWITCHES	
0 PLC ± -		PRODUCT SPEC		SIZE A2	
1 PLC ± 0.38[.015]		APPLICATION SPEC		CAGE CODE 00779	
2 PLC ± 0.25[.010]		WEIGHT		DRAWING NO C=2267088	
3 PLC ± -		CUSTOMER DRAWING		RESTRICTED TO	
4 PLC ± -		SCALE 3:1		SHEET 4 of 5	
ANGLES ± 5°		REV A1			
MATERIAL					
FINISH					

REVISIONS					
P	LTR	DESCRIPTION	DATE	DWN	APVD
-	-	SEE SHEET 1	-	-	-

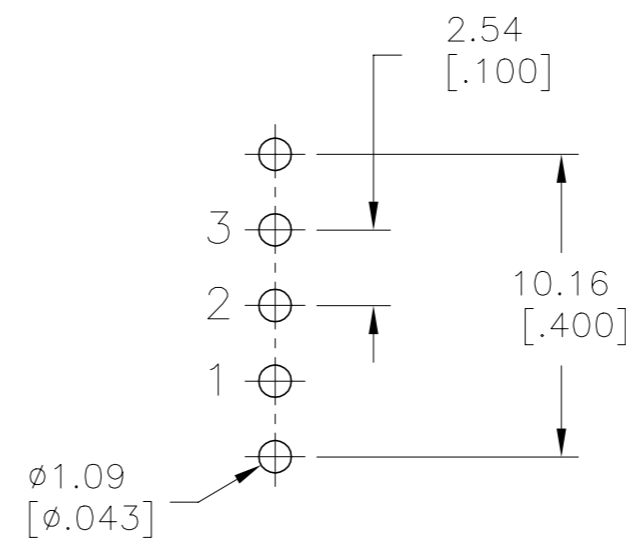
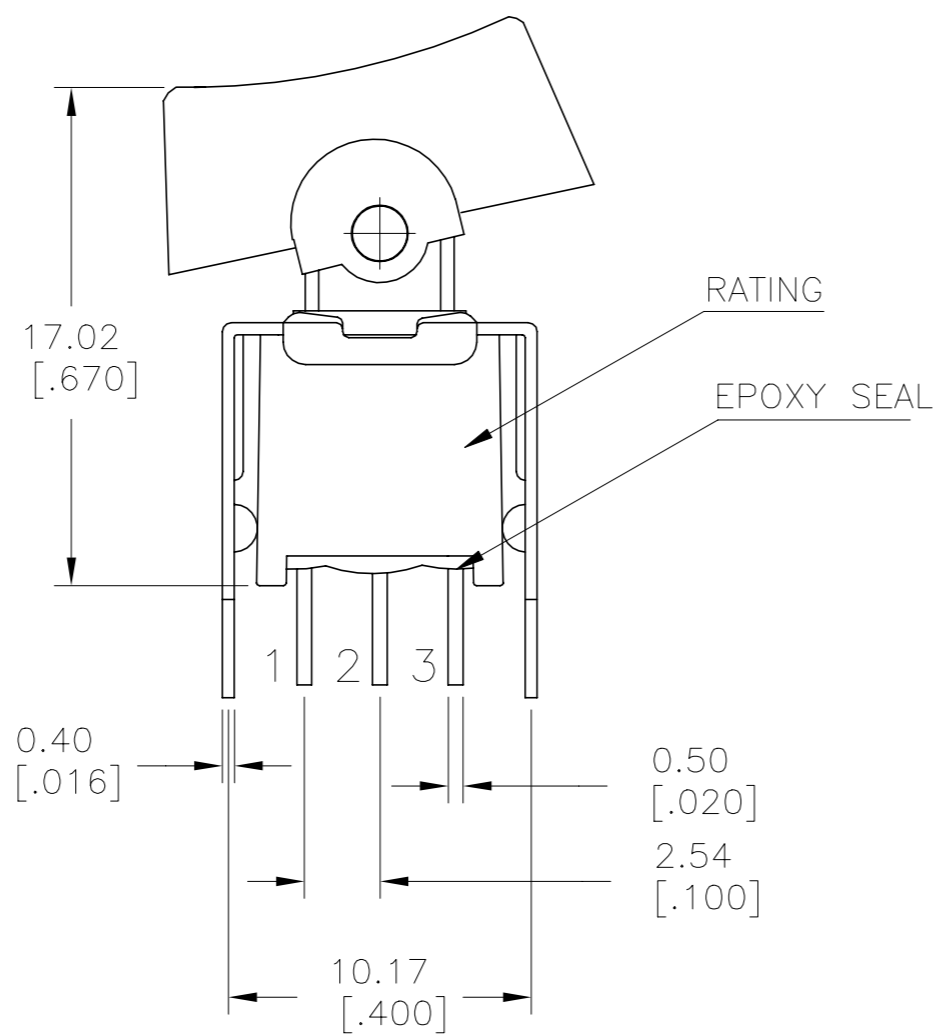
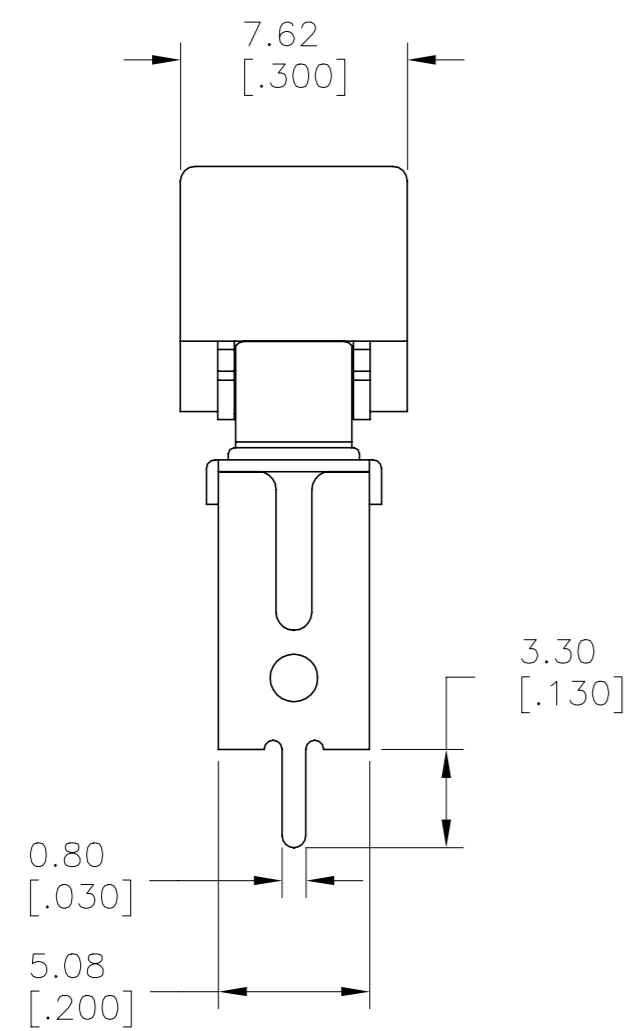

SPDT VS2
VERTICAL V-BRACKET

P.C. MOUNTING

D

D

C

C

B

B

2267088

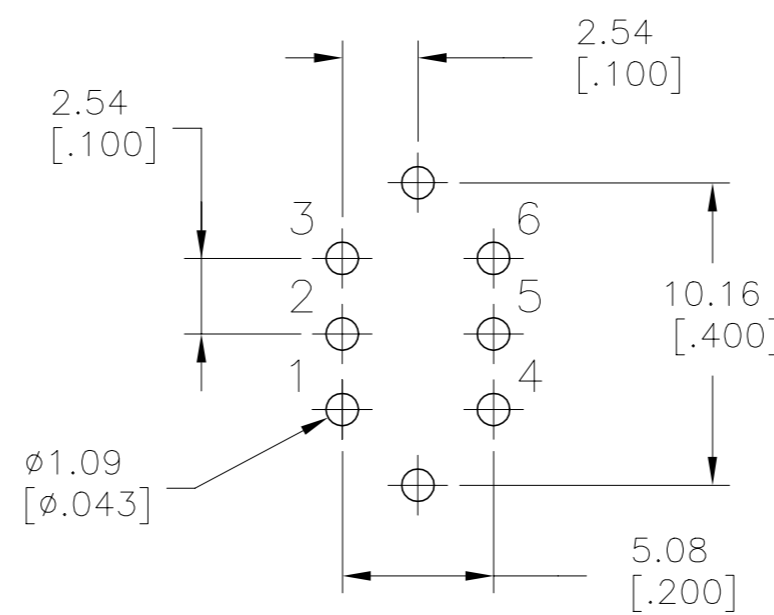
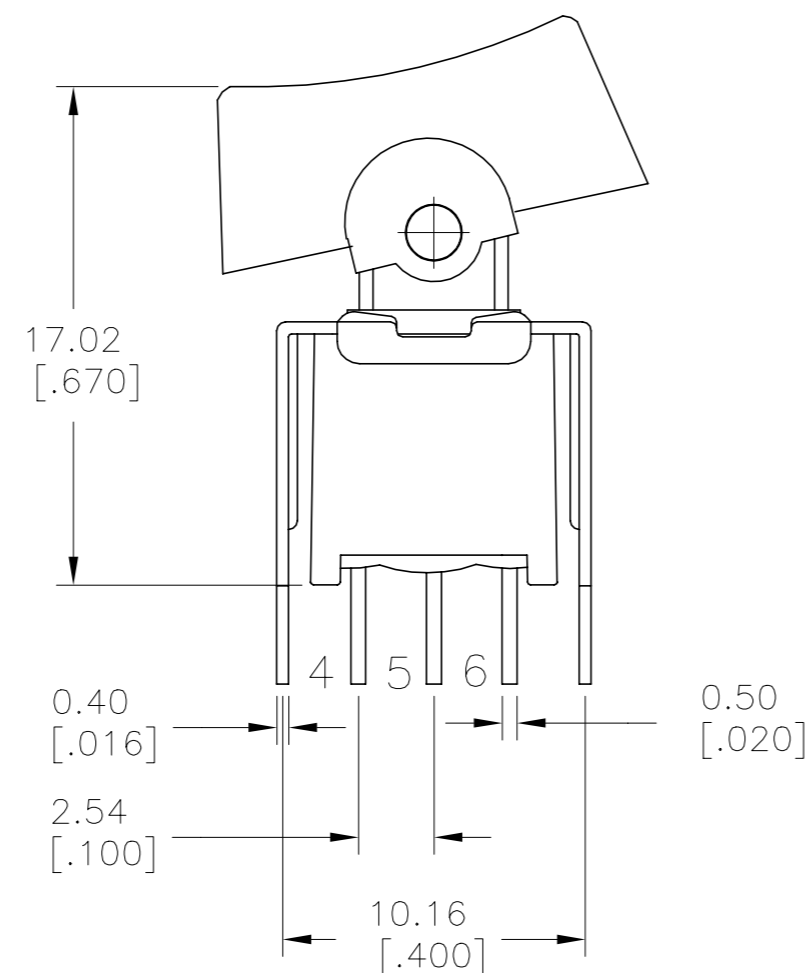
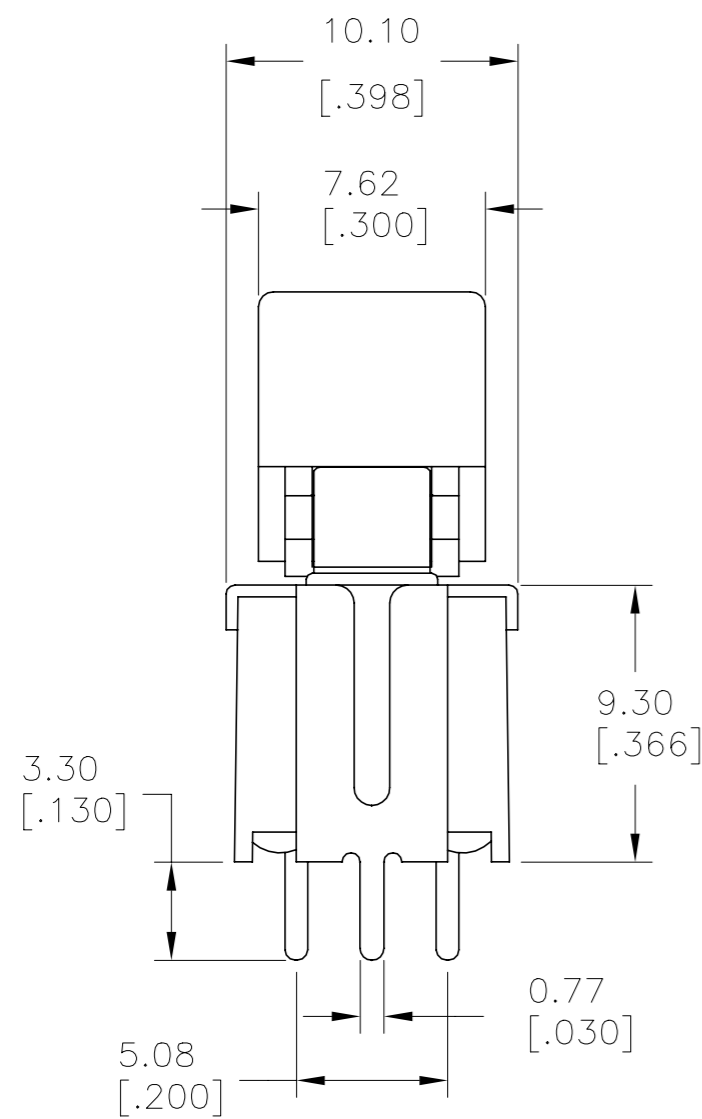

DPDT VS2
VERTICAL V-BRACKET

P.C. MOUNTING

LAYOUT FOR PN 2267088-7 & 8

A

A

THIS DRAWING IS A CONTROLLED DOCUMENT.		DWN NAGALAKSHMI K 10JUL2014	TE Connectivity Ltd.	
DIMENSIONS: mm [INCHES]		CHK HILL, RYAN 10JUL2014		
TOLERANCES UNLESS OTHERWISE SPECIFIED:		APVD HILL, RYAN 10JUL2014		RESTRICTED TO
0 PLC ± - 1 PLC ± 0.38[.015] 2 PLC ± 0.25[.010] 3 PLC ± - 4 PLC ± - ANGLES ± 5°		PRODUCT SPEC		SIZE A2
MATERIAL		APPLICATION SPEC		CAGE CODE 00779
FINISH		WEIGHT		DRAWING NO C=2267088
		CUSTOMER DRAWING		SCALE 3:1
				SHEET 5 of 5
				REV A1