

SF2037C

76.500 MHz
SAW Filter

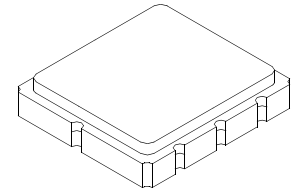

SM5050-8

- *Designed for SDARS IF Receiver*
- *5.0 X 5.0 mm Surface-mount Case*
- *Differential or Single-ended Input and Output*
- *Complies with Directive 2002/95/EC (RoHS)*
- *Moisture Sensitivity Level: 1*
- *AEC-Q200 Qualified*

Absolute Maximum Ratings

Rating	Value	Units
Maximum Incident Power in Passband	+10	dBm
Maximum DC Voltage on any Non-ground Terminal	30	VDC
Storage Temperature Range in Tape and Reel	-40 to +85	°C
Maximum Soldering Profile	265 °C for 10 s	

Electrical Characteristics

Characteristic	Sym	Notes	Min	Typ	Max	Units
Center Frequency	f_C			76.500		MHz
Insertion Loss	IL			10.0	12.0	dB
1 dB Bandwidth	BW_1		3.8	4.4		MHz
15 dB Bandwidth	BW_{15}			7.1	7.4	MHz
30 dB Bandwidth	BW_{30}			8.2	8.5	MHz
Amplitude Ripple, $f_C \pm 1.9$ MHz				0.7	1.10	dB _{P-P}
Group Delay Ripple, $f_C \pm 1.9$ MHz	GDV			55	150	ns _{P-P}
Rejection:						dB
50 to 70.44 MHz			34	41		
70.44 to 72.04 MHz			31	37		
81.26 to 82.56 MHz			36	42		
82.56 to 86.50 MHz			36	43		
86.5 to 91.50 MHz			40	46		
91.50 to 100.00 MHz			42	51		
Operating Temperature Range	T_A		-40		+85	°C
Frequency Temperature Coefficient	FTC			-18		ppm/°C
Differential Input				175 ohms		
Differential Output				1000 ohms		
Case Style				SM5050-8 5 x 5 mm Nominal Footprint		
Lid Symbolization (Y=year, WW=week, S=shift)				912, <u>YWWS</u>		

 **CAUTION: Electrostatic Sensitive Device. Observe precautions for handling.**

NOTES:

1. The design, manufacturing process, and specifications of this device are subject to change.
2. US or International patents may apply.
3. RoHS compliant from the first date of manufacture.

Filter Amplitude Response Plot, 56.5 to 96.5 MHz

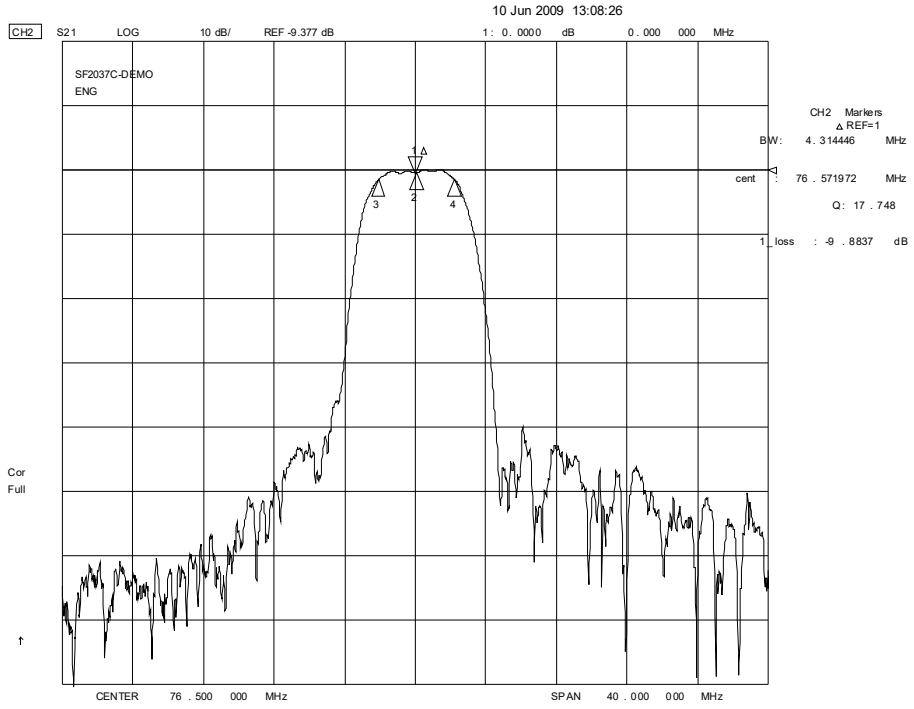

Filter Passband Amplitude Plot

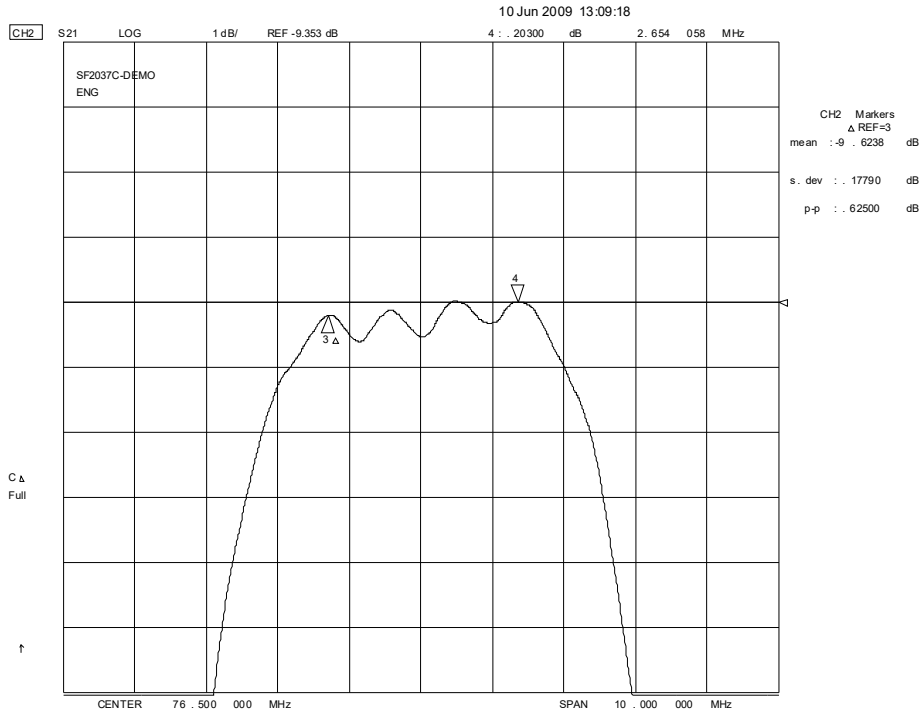

Filter Passband Group Delay Plot

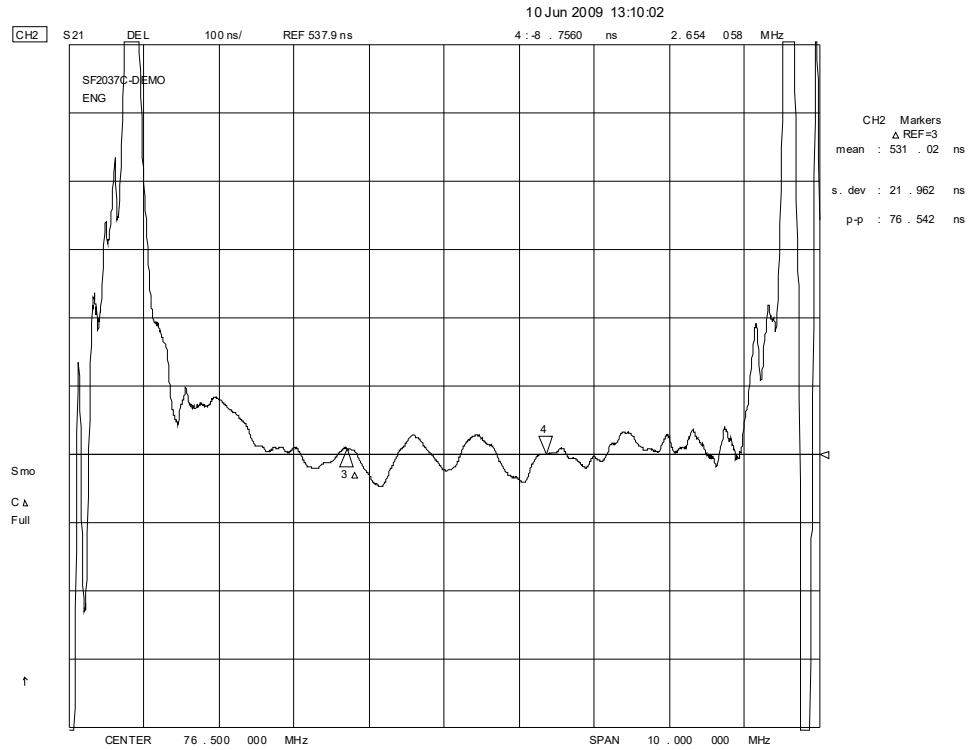

Filter Input and Output Impedance Plots

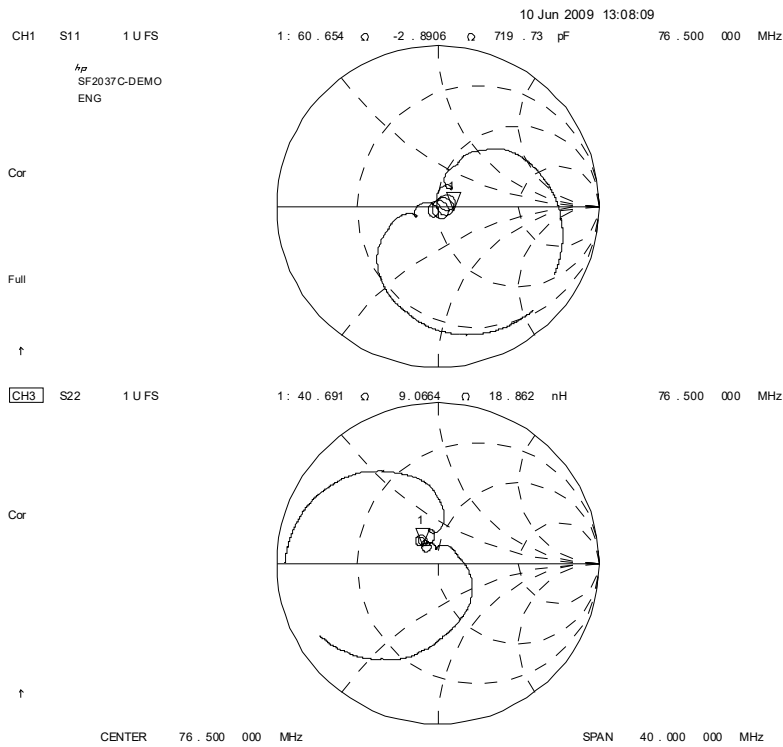

SM5050-8 Surface-Mount 8-Terminal Ceramic Case

5.0 X 5.0 mm Nominal Footprint

Case Dimensions

Dimension	mm			Inches		
	Min	Nom	Max	Min	Nom	Max
A	4.80	5.00	5.20	0.189	0.197	0.205
B	4.80	5.00	5.20	0.189	0.197	0.205
C	1.30	1.50	1.70	0.050	0.060	0.067
D	1.98	2.08	2.18	0.078	0.082	0.086
E	1.07	1.17	1.27	0.042	0.046	0.050
F	0.50	0.64	0.70	0.020	0.025	0.028
G	2.39	2.54	2.69	0.094	0.100	0.106
H		1.27			0.050	
I		0.76			0.030	
J		1.55			0.061	
K		2.79			0.110	
L		0.76			0.030	
M		2.36			0.093	
N		1.55			0.061	
O		2.79			0.110	
P		2.79			0.110	
Q		2.79			0.110	

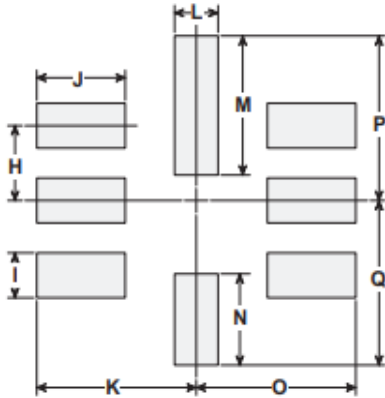
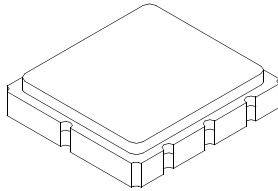

PCB Footprint

SF2037C Demo Board

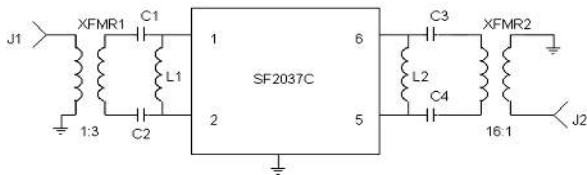

- C1,C2 501-0621-090 90pF 0603
- C3,C4 501-0621-180 180pF 0603
- L1,L2 501-1068-331 330nH 0603CS
- XFMR1 501-0912-003 3:1 Transformer
- XFMR2 501-0912-004 16:1 Transformer
- PCB 401-1706-001 5x5 PCB pins 1, 2 & 5, 6
- J1, J2 500-1241-001 SMA e-snap fem gold conn.

Case Materials

Materials	
Solder Pad Plating	0.3 to 1.0 μ m Gold over 1.27 to 8.89 μ m Nickel
Lid Plating	2.0 to 3.0 μ m Nickel
Body	Al ₂ O ₃ Ceramic

Electrical Connections

Connection		Terminals
Port 1	Differential Input	1, 2
Port 2	Differential Output	5, 6
	Ground	All others
Single-ended Operation		Return is ground
Differential Operation		Return is hot
Dot indicates Pin 1		

TOP VIEW

BOTTOM VIEW

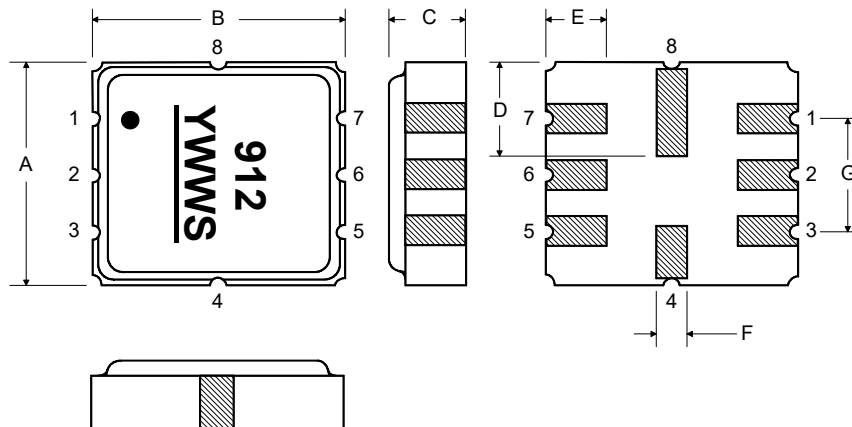

Tape and Reel Specifications

Tape and Reel Standard per ANSI/EIA-481

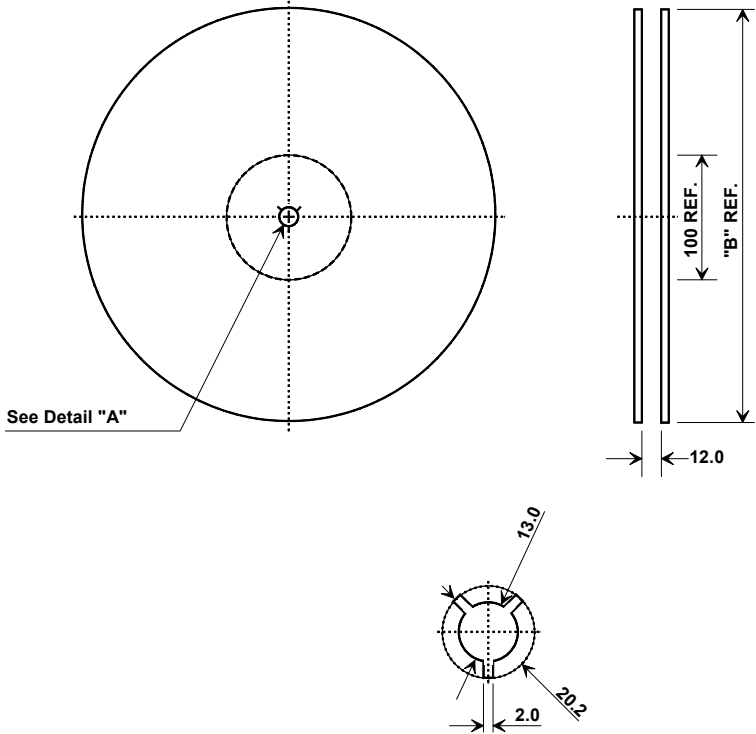

"B"		Quantity Per Reel
Nominal Size		
Inches	millimeters	
7	178	500
13	330	3000

COMPONENT ORIENTATION and DIMENSIONS

Carrier Tape Dimensions	
Ao	5.3 mm
Bo	5.3 mm
Ko	2.0 mm
Pitch	8.0 mm
W	12.0 mm

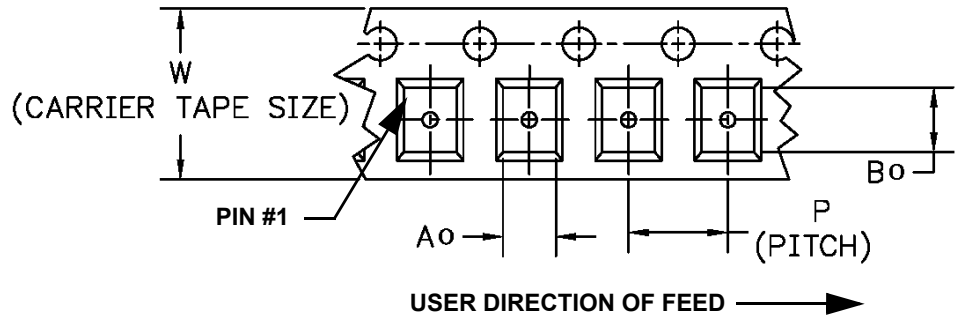
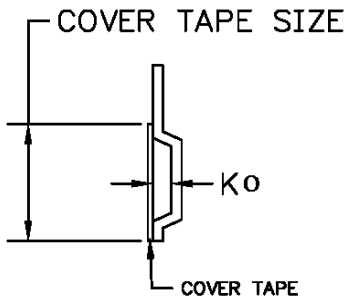

Recommended Reflow Profile

1. Preheating shall be fixed at 150~180°C for 60~90 seconds.
2. Ascending time to preheating temperature 150°C shall be 30 seconds min.
3. Heating shall be fixed at 220°C for 50~80 seconds and at 260°C+0/-5°C peak (10 seconds).
4. Time: 5 times maximum.

