

AirborneM2M™ Dual Band (2.4 GHz, 5 GHz) Wi-Fi Industrial Ethernet Access Point – Embedded OEM & Carrier Board Model BB-APXN-DP553

ADVANTECH

www.advantech.com



PRODUCT FEATURES

- 802.11a/b/g/n, dual band (2.4, 5 GHz) Wi-Fi Ethernet access point
- Up to 65 Mbps (band dependent)
- Wide operating temperature: -20 to +85 °C
- Supports up to 9 Wi-Fi clients
- OEM open board, industrial design
- Advanced Enterprise class wireless security
- Antenna and power supply required (not included, sold separately)

Model BB-APXN-DP553, AirborneM2M industrial wireless access point, is built for networking equipment in an array of machine-to-machine (M2M) applications. It features industrial-strength packaging and supports a wide operating temperature (-20 to +85°C) to withstand challenging M2M environments.

Access Point - This AirborneM2M access point enables M2M equipment to create a self sufficient Wi-Fi network and provides easy access to equipment data or resources from Wi-Fi enabled devices. It includes a DHCP server. Up to 9 clients can be supported on the local Wi-Fi network.

Dual-Band Wi-Fi - Model BB-APXN-DP553 establishes wireless connections over both 2.4 GHz and 5 GHz bands. Whenever the 2.4 GHz airspace is overcrowded with competing wireless transmission, the access point can be switched over to 5 GHz band to keep data flowing.

Enterprise Class Security - Security protocols are important to mission critical wireless M2M applications. AirborneM2M access point's multi-layer security meets the requirements of Enterprise-class networks and corporate IT departments. These advanced security features include wireless security (802.11i/WAP2 enterprise), authentication security using WPA2 (AES-CCMP) and device security (multi-layered encryption).

Powering - external 5-36 VDC power source required. (USA power cord included, other cords sold separately.)

ORDERING INFORMATION

MODEL NUMBER	DESCRIPTION
BB-APXN-DP553	Industrial Access Point Embedded OEM board 802.11a/b/g/n Dual band (2.4 GHz, 5 GHz)

ACCESSORIES – sold separately

BB-PS-WDS – 120-240VAC, 50/60Hz, 5VDC, 2A, barrel connector power supply
(Note: includes USA cord; other cords sold separately.)

BB-ACH2-DBAT-DP003 – 3.8/5.5 dBi, 2.4/5GHz antenna, rubber duck, RP-SMA antenna

BB-ACH0-CA-DP003-G – Airborne Ethernet cable, RJ-45 to Hirose 7-position connector

All product specifications are subject to change without notice.
BB-APXN-DP553_AccessPoint_2320ds

ADVANTECH

Advantech B+B SmartWorx, 707 Dayton Road, PO Box 1040 Ottawa, IL 61350 USA 1 (800)346-3119/Toll Free | orders@advantech-bb.com | support@advantech-bb.com

AirborneM2M™ Dual Band (2.4 GHz, 5 GHz) Wi-Fi Industrial Ethernet Access Point – Embedded OEM & Carrier Board Model BB-APXN-DP553



ETHERNET PORT

J8 - Hirose# DF13-7P-1.25V(50)
Mating Connector - Hirose# DF13-7S-1.25C

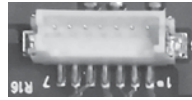

Seven Pins
7 6 5 4 3 2 1

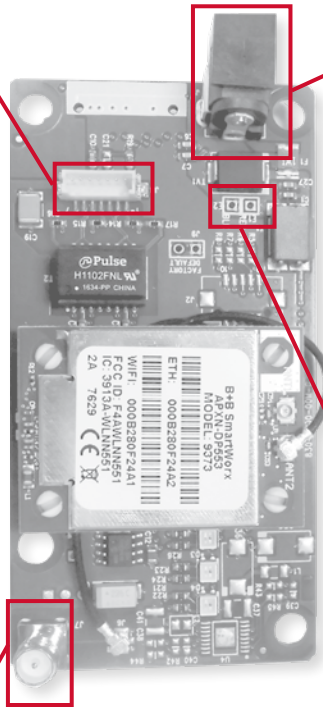
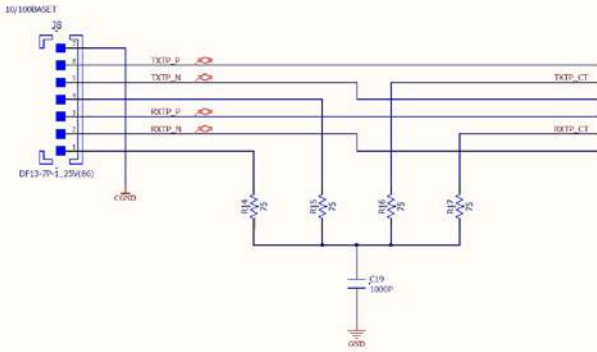

POWER

J1 - Switchcraft RAPC722X
Mating Connector - Switchcraft S760

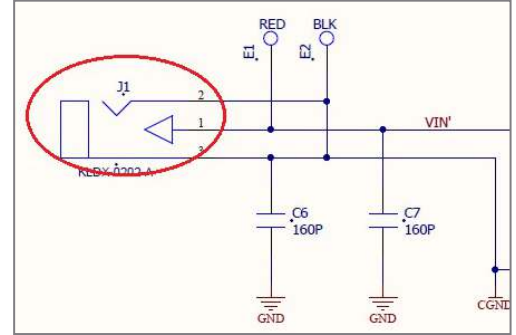

PADS

Pads can be used to connect power instead of barrel jack.

On the board:

- E2 is on the Left.
- E1 is on the Right.

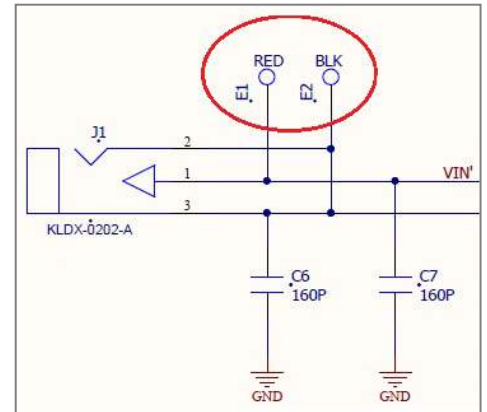
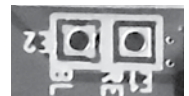

ANTENNA

NOTE: ANT 2 on the WiFi module is connected to J6 on the mother board using the included cable assembly. ANT 2 and J2 connectors are limited-use U.FL connectors.



If you desire to move these connections, use caution as damage may occur. J2, the main antenna connection, is an RP-SMA. The WiFi module is certified for use with the antenna listed in the accessory section.

AirborneM2M™ Dual Band (2.4 GHz, 5 GHz) Wi-Fi Industrial Ethernet Access Point – Embedded OEM & Carrier Board Model BB-APXN-DP553



SPECIFICATIONS

TECHNOLOGY	
Wireless Technology	IEEE 802.11 a/b/g/n, Wi-Fi compatible
Frequency	2.4~2.4835 GHz (US/Canada/Europe) 2.4~2.497 GHz (Japan) 5.150 ~ 5.350 GHz 5.725 ~ 5.825 GHz
Modulation Technology	DSSS, CCK, OFDM
Modulation Type	DBPSK, DQPSK, CCK, BPSK, QPSK, 16QAM, 64QAM
Network Access Modes	Access Point Infrastructure (Client), Ad Hoc
Wireless Data Rates	802.11a/g = 54, 48, 36, 24, 18, 12, 9, 6 Mbps 802.11b = 11, 5.5, 2, 1 Mbps 802.11n = 65, 58.5, 42, 39, 26, 19.5, 13, 6.5 Mbps
Network Protocols	TCP/IP, ARP, ICMP, DHCP, DNS, UDAP, TFTP, UDP, PING, HTTP, FTP
Receive Sensitivity - 802.11 b/g	54Mb/s = -72 dBm 36Mb/s = -78 dBm 18Mb/s = -84 dBm 6Mb/s = -89 dBm 11Mb/s = -86 dBm 1Mb/s = -92 dBm
Receive Sensitivity - 802.11 a	54Mb/s = -74 dBm 36Mb/s = -80 dBm 36Mb/s = -80 dBm 6Mb/s = -90 dBm
Wireless Security	Open, WEP 64 & 128 bit, WPA-PSK (TKIP), WPA2-PSK (AES), 802.1x (EAP), WPA-Enterprise, WPA2-Enterprise, EAP-TLS/MSCHAPv2, EAP-TTLS/MSCHAPv2, EAP-TTLS (MD5), EAP-PEAPv0/MSCHAPv2, LEAP Zero host security footprint. Advanced certificate storage and management.
Secure Network Communications	SSH and SSL tunneling. Encrypted configuration.
Transmit Power	802.11b = 15 dBm (31.6 mW) 802.11g = 12.6dBm (18.12 mW) 802.11a = 17 dBm (50.1 mW)
POWER	
Input Voltage	5 VDC
Power Connection	2.1 mm barrel jack
ENVIRONMENTAL	
Operating Temperature	-20 to +85 °C
Storage Temperature	-40 to +85 °C
Operating Humidity	5 to 95% (non-condensing)
MECHANICAL	
Open Board Design	Dimensions: 120.14 x 120.12 x 29.21 mm (4.89 x 4.73 x 1.15 in)
MEANTIME BETWEEN FAILURE (MTBF)	
MTBF	450186 hours
MTBF Calc. Method	MIL 217F Parts Count Reliability Prediction

SPECIFICATIONS – continued

APPROVALS, DIRECTIVES, STANDARDS	
ECCN Code	5A992 ext. a
Commodity Code	8517620050
North America	FCC Part 15.247, Class B Sub C Modular Approval
Canada	Industry Canada RSS-210
CE - Directives (Europe)	2014/35/EU - Low Voltage Directive 2014/53/EU - Radio Equipment Directive (RED) Hereby, Advantech B+B SmartWorx declares that the radio equipment type 802.11a/b/g/n access point is in compliance with Directive 2014/53/EU. The full text of the EU declaration of conformity is available at the following internet address: www.advantech-bb.com 2011/65/EU amended by (EU) 2015/863 Reduction of Hazardous Substances Directive (RoHS) 2012/19/EU - Waste Electrical & Electronic Equipment Directive (WEEE)
CE - Standards (Europe)	EMC: ETSI EN 300 328 v2.1.1 - EMC & Radio Spectrum Matters (ERM) Wideband Transmission Systems - 2.4 GHz ISM Band ETSI EN 301 893 v2.1.1 - EMC & Radio Spectrum Matters (ERM) Wideband Transmission Systems - 5 GHz ISM Band ETSI EN 301 489-1 v2.1.1 - Applied in accordance with the specific requirements of: ETSI EN 301 489-17 v3.1.1 - EMC & Radio Spectrum Matters (ERM) Broadband Data Systems EN 55032+AC, Class A - Information technology equipment – RF Emissions EN 55024 - Information Technology Equipment (ITE) - Immunity Characteristics - Limits and Methods of Measurement Safety: EN 60950-1 + A1 + A11 + A12 + A2 - Information Technology Equipment (ITE) - Safety - Part 1: General Requirements RF Exposure: EN 62311 - Assessment of electronic and electrical equipment related to human exposure restrictions for EM fields (0 Hz to 300 GHz)

MECHANICAL DIAGRAM

Units = mm [in]

