



**MICROCHIP**

---

**MCP73830L 2x2 TDFN  
Li-Ion Battery Charger  
Evaluation Board  
User's Guide**

---

**Note the following details of the code protection feature on Microchip devices:**

- Microchip products meet the specification contained in their particular Microchip Data Sheet.
- Microchip believes that its family of products is one of the most secure families of its kind on the market today, when used in the intended manner and under normal conditions.
- There are dishonest and possibly illegal methods used to breach the code protection feature. All of these methods, to our knowledge, require using the Microchip products in a manner outside the operating specifications contained in Microchip's Data Sheets. Most likely, the person doing so is engaged in theft of intellectual property.
- Microchip is willing to work with the customer who is concerned about the integrity of their code.
- Neither Microchip nor any other semiconductor manufacturer can guarantee the security of their code. Code protection does not mean that we are guaranteeing the product as "unbreakable."

Code protection is constantly evolving. We at Microchip are committed to continuously improving the code protection features of our products. Attempts to break Microchip's code protection feature may be a violation of the Digital Millennium Copyright Act. If such acts allow unauthorized access to your software or other copyrighted work, you may have a right to sue for relief under that Act.

---

Information contained in this publication regarding device applications and the like is provided only for your convenience and may be superseded by updates. It is your responsibility to ensure that your application meets with your specifications. MICROCHIP MAKES NO REPRESENTATIONS OR WARRANTIES OF ANY KIND WHETHER EXPRESS OR IMPLIED, WRITTEN OR ORAL, STATUTORY OR OTHERWISE, RELATED TO THE INFORMATION, INCLUDING BUT NOT LIMITED TO ITS CONDITION, QUALITY, PERFORMANCE, MERCHANTABILITY OR FITNESS FOR PURPOSE. Microchip disclaims all liability arising from this information and its use. Use of Microchip devices in life support and/or safety applications is entirely at the buyer's risk, and the buyer agrees to defend, indemnify and hold harmless Microchip from any and all damages, claims, suits, or expenses resulting from such use. No licenses are conveyed, implicitly or otherwise, under any Microchip intellectual property rights.

**Trademarks**

The Microchip name and logo, the Microchip logo, dsPIC, KEELOQ, KEELOQ logo, MPLAB, PIC, PICmicro, PICSTART, PIC<sup>32</sup> logo, rfPIC and UNI/O are registered trademarks of Microchip Technology Incorporated in the U.S.A. and other countries.

FilterLab, Hampshire, HI-TECH C, Linear Active Thermistor, MXDEV, MXLAB, SEEVAL and The Embedded Control Solutions Company are registered trademarks of Microchip Technology Incorporated in the U.S.A.

Analog-for-the-Digital Age, Application Maestro, chipKIT, chipKIT logo, CodeGuard, dsPICDEM, dsPICDEM.net, dsPICworks, dsSPEAK, ECAN, ECONOMONITOR, FanSense, HI-TIDE, In-Circuit Serial Programming, ICSP, Mindi, MiWi, MPASM, MPLAB Certified logo, MPLIB, MPLINK, mTouch, Omniscient Code Generation, PICC, PICC-18, PICDEM, PICDEM.net, PICkit, PICtail, REAL ICE, rfLAB, Select Mode, Total Endurance, TSHARC, UniWinDriver, WiperLock and ZENA are trademarks of Microchip Technology Incorporated in the U.S.A. and other countries.

SQTP is a service mark of Microchip Technology Incorporated in the U.S.A.

All other trademarks mentioned herein are property of their respective companies.

© 2011, Microchip Technology Incorporated, Printed in the U.S.A., All Rights Reserved.

 Printed on recycled paper.

ISBN: 978-1-61341-454-5

**QUALITY MANAGEMENT SYSTEM**  
**CERTIFIED BY DNV**  
**== ISO/TS 16949:2009 ==**

*Microchip received ISO/TS-16949:2009 certification for its worldwide headquarters, design and wafer fabrication facilities in Chandler and Tempe, Arizona; Gresham, Oregon and design centers in California and India. The Company's quality system processes and procedures are for its PIC<sup>®</sup> MCUs and dsPIC<sup>®</sup> DSCs, KEELOQ<sup>®</sup> code hopping devices, Serial EEPROMs, microperipherals, nonvolatile memory and analog products. In addition, Microchip's quality system for the design and manufacture of development systems is ISO 9001:2000 certified.*



# MCP73830L 2X2 TDFN LI-ION BATTERY CHARGER EVALUATION BOARD USER'S GUIDE

---

---

## Table of Contents

---

---

<b>Preface</b> .....	<b>5</b>
Introduction.....	5
Document Layout .....	5
Conventions Used in this Guide .....	6
Recommended Reading.....	7
The Microchip Web Site .....	7
Customer Support .....	7
Document Revision History .....	7
<b>Chapter 1. Product Overview</b>	
1.1 Introduction .....	9
1.2 What is the MCP73830L 2x2 TDFN Li-Ion Battery Charger Evaluation Board? .....	10
1.3 What the MCP73830L 2x2 TDFN Li-Ion Battery Charger Evaluation Board Kit Includes .....	10
<b>Chapter 1. Installation and Operation</b>	
1.1 Introduction .....	11
1.2 Features .....	11
1.3 Getting Started .....	12
<b>Appendix A. Schematic and Layouts</b>	
A.1 Introduction .....	13
A.2 Board – Schematic .....	14
A.3 Board – Top Layer .....	15
A.4 Board – Top Copper .....	15
A.5 Board – Bottom Copper .....	16
<b>Appendix B. Bill of Materials</b>	
<b>Worldwide Sales and Service</b> .....	<b>18</b>





# MCP73830L 2X2 TDFN LI-ION BATTERY CHARGER EVALUATION BOARD USER'S GUIDE

---

---

## Preface

---

---

### NOTICE TO CUSTOMERS

All documentation becomes dated, and this manual is no exception. Microchip tools and documentation are constantly evolving to meet customer needs, so some actual dialogs and/or tool descriptions may differ from those in this document. Please refer to our web site ([www.microchip.com](http://www.microchip.com)) to obtain the latest documentation available.

Documents are identified with a “DS” number. This number is located on the bottom of each page, in front of the page number. The numbering convention for the DS number is “DSXXXXA”, where “XXXX” is the document number and “A” is the revision level of the document.

For the most up-to-date information on development tools, see the MPLAB® IDE on-line help. Select the Help menu, and then Topics to open a list of available on line help files.

## INTRODUCTION

This chapter contains general information that will be useful to know before using the MCP73830L 2x2 TDFN Li-Ion Battery Charger Evaluation Board. Items discussed in this chapter include:

- Document Layout
- Conventions Used in this Guide
- Recommended Reading
- The Microchip Web Site
- Customer Support
- Document Revision History

## DOCUMENT LAYOUT

This document describes how to use the MCP73830L 2x2 TDFN Li-Ion Battery Charger Evaluation Board. The manual layout is as follows:

- **Chapter 1. “Product Overview”** – Important information about the MCP73830L 2x2 TDFN Li-Ion Battery Charger Evaluation Board.
- **Chapter 1. “Installation and Operation”** – Includes instructions on how to get started with MCP73830L 2x2 TDFN Li-Ion Battery Charger Evaluation Board and a description of the user's guide.
- **Appendix A. “Schematic and Layouts”** – Shows the schematic and layout diagrams for the MCP73830L 2x2 TDFN Li-Ion Battery Charger Evaluation Board.
- **Appendix B. “Bill of Materials”** – Lists the parts used to build the MCP73830L 2x2 TDFN Li-Ion Battery Charger Evaluation Board.

## CONVENTIONS USED IN THIS GUIDE

This manual uses the following documentation conventions:

### DOCUMENTATION CONVENTIONS

Description	Represents	Examples
<b>Arial font:</b>		
Italic characters	Referenced books	<i>MPLAB<sup>®</sup> IDE User's Guide</i>
	Emphasized text	...is the <i>only</i> compiler...
Initial caps	A window	the Output window
	A dialog	the Settings dialog
	A menu selection	select Enable Programmer
Quotes	A field name in a window or dialog	"Save project before build"
Underlined, italic text with right angle bracket	A menu path	<u><i>File&gt;Save</i></u>
Bold characters	A dialog button	Click <b>OK</b>
	A tab	Click the <b>Power</b> tab
N'Rnnnn	A number in verilog format, where N is the total number of digits, R is the radix and n is a digit.	4'b0010, 2'hF1
Text in angle brackets < >	A key on the keyboard	Press <Enter>, <F1>
<b>Courier New font:</b>		
Plain Courier New	Sample source code	#define START
	Filenames	autoexec.bat
	File paths	c:\mcc18\h
	Keywords	_asm, _endasm, static
	Command-line options	-Opa+, -Opa-
	Bit values	0, 1
	Constants	0xFF, 'A'
Italic Courier New	A variable argument	<i>file.o</i> , where <i>file</i> can be any valid filename
Square brackets [ ]	Optional arguments	mcc18 [options] <i>file</i> [options]
Curly brackets and pipe character: {   }	Choice of mutually exclusive arguments; an OR selection	errorlevel {0 1}
Ellipses...	Replaces repeated text	var_name [, var_name...]
	Represents code supplied by user	void main (void) { ... }

## RECOMMENDED READING

This user's guide describes how to use MCP73830L 2x2 TDFN Li-Ion Battery Charger Evaluation Board. Other useful documents are listed below. The following Microchip documents are available and recommended as supplemental reference resources.

- **MCP73830L Data Sheet - “Single-Cell Li-Ion/Li-Polymer Battery Charge Management Controllers in 2x2 TDFN” (DS25049)**

## THE MICROCHIP WEB SITE

Microchip provides online support via our web site at [www.microchip.com](http://www.microchip.com). This web site is used as a means to make files and information easily available to customers. Accessible by using your favorite Internet browser, the web site contains the following information:

- **Product Support** – Data sheets and errata, application notes and sample programs, design resources, user's guides and hardware support documents, latest software releases and archived software
- **General Technical Support** – Frequently Asked Questions (FAQs), technical support requests, online discussion groups, Microchip consultant program member listing
- **Business of Microchip** – Product selector and ordering guides, latest Microchip press releases, listing of seminars and events, listings of Microchip sales offices, distributors and factory representatives

## CUSTOMER SUPPORT

Users of Microchip products can receive assistance through several channels:

- Distributor or Representative
- Local Sales Office
- Field Application Engineer (FAE)
- Technical Support

Customers should contact their distributor, representative or field application engineer (FAE) for support. Local sales offices are also available to help customers. A listing of sales offices and locations is included in the back of this document.

Technical support is available through the web site at: <http://support.microchip.com>.

## DOCUMENT REVISION HISTORY

### Revision A (August 2011)

- Initial Release of this Document.

NOTES:



**Chapter 1. Product Overview**

**1.1 INTRODUCTION**

The MCP73830L 2x2 TDFN Li-Ion Battery Charger Evaluation Board demonstrates the features and abilities of Microchip's MCP73830L Single-Chip Linear Li-Ion Battery Charger. The MCP73830L is a stand-alone, highly integrated linear battery charge management controller that employs a constant current / constant voltage (CCCV) charge algorithm with selectable preconditioning and charge termination. The charge algorithm is provided for Li-Ion / Li-Polymer battery packs to achieve optimal capacity in the shortest charging time possible.

The MCP73830L uses an external resistor ( $R_{PROG}$ ) to set the magnitude of the charge current up to a maximum of 200 mA.

This chapter covers the following topics:

- "What is the MCP73830L 2x2 TDFN Li-Ion Battery Charger Evaluation Board?"
- "What the MCP73830L 2x2 TDFN Li-Ion Battery Charger Evaluation Board Kit Includes."

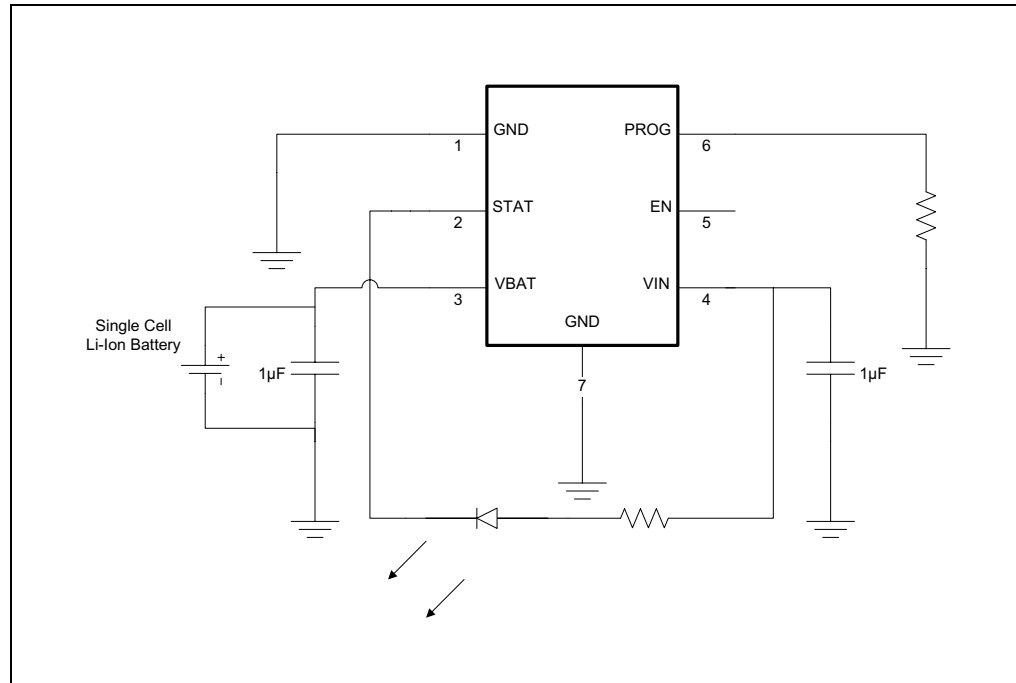

**FIGURE 1-1:** MCP73830L Typical Application Circuit.

## 1.2 WHAT IS THE MCP73830L 2X2 TDFN LI-ION BATTERY CHARGER EVALUATION BOARD?

The MCP73830L 2x2 TDFN Li-Ion Battery Charger Evaluation Board demonstrates the use of Single-Chip Linear Li-Ion Battery Charger with programmable charge current.

The MCP73830L 2x2 TDFN Li-Ion Battery Charger Evaluation Board is set up to evaluate single-cell Li-Ion battery charge management. This board utilizes Microchip's MCP73830L that effectively charges Li-Ion batteries with high-accuracy, preset-voltage regulation. The MCP73830L 2x2 TDFN Li-Ion Battery Charger Evaluation Board comes with a pre-installed 2 mm x 2 mm TDFN-6 MCP73830L. This circuit is ready to charge Li-Ion batteries at a maximum charge current rate up to 200 mA.

A built-in LED is used to display the charge status (STAT).

The MCP73830L has an internal safety timer and will terminate the charge cycle when the timer has expired.

The MCP73830L 2x2 TDFN Li-Ion Battery Charger Evaluation Board is designed to observe the performance and features on the circuits via multiple test points. Users can also discover the compact size of the layout in addition to the device itself. The circuit can also be implemented into suitable applications without additional work.

## 1.3 WHAT THE MCP73830L 2X2 TDFN LI-ION BATTERY CHARGER EVALUATION BOARD KIT INCLUDES

This MCP73830L 2x2 TDFN Li-Ion Battery Charger Evaluation Board kit includes:

- MCP73830L 2x2 TDFN Li-Ion Battery Charger Evaluation Board, 102-00313-R1
- Important Information Sheet



# MCP73830L 2X2 TDFN LI-ION BATTERY CHARGER EVALUATION BOARD USER'S GUIDE

---

---

## Chapter 1. Installation and Operation

---

---

### 1.1 INTRODUCTION

The MCP73830L 2x2 TDFN Li-Ion Battery Charger Evaluation Board demonstrates Microchip's stand-alone Linear Li-Ion Battery Charger in a simple and compact design.

The MCP73830L requires only a minimum number of components to implement a complete battery charge management circuit.

The MCP73830L 2x2 TDFN Li-Ion Battery Charger Evaluation Board comes with a 6-pin TDFN MCP73830L pre-installed.

Typical applications for MCP73830L are MP3 players, USB-powered systems, handheld medical instruments, Bluetooth headsets and portable devices.

### 1.2 FEATURES

The MCP73830L 2x2 TDFN Li-Ion Battery Charger Evaluation Board has the following features:

- 2x2 TDFN-6 Package Size
- Programmable charge current between 20 mA to 200 mA
- A status LED to indicate charge status
- EN pin to enable/disable charger
- A preset internal safety timer
- Built-in Under Voltage Current Limit Control

## 1.3 GETTING STARTED

The MCP73830L 2x2 TDFN Li-Ion Battery Charger Evaluation Board is fully assembled and tested for charging a single-cell Li-Ion or Li-Polymer battery with an input supply of 3.75V to 6V.

### 1.3.1 Power Input and Output Connection

#### 1.3.1.1 POWERING THE MCP73830L 2X2 TDFN LI-ION BATTERY CHARGER EVALUATION BOARD

1. Connect the positive battery terminal to  $V_{BAT}$  and negative battery terminal to GND.
2. Connect the DC power supply Negative terminal to GND.
3. Connect the 5V DC power supply Positive terminal to  $V_{IN}$ .
4. It should initiate the battery charging cycle when the power source is present.

**Note:** The battery voltage needs to be below 4.05V (typical) in order to initiate a new charging cycle.

5. Charging current should be able to read off the multi-meter that is in series with battery.

**Note:** The battery can be replaced with test circuit or electronic load that can sync current with the DC power supply.

6. Pulling EN pin high disables charging activities.
7. Fast Charge Current can be programmed with various resistors that are based on Figure 1-1.

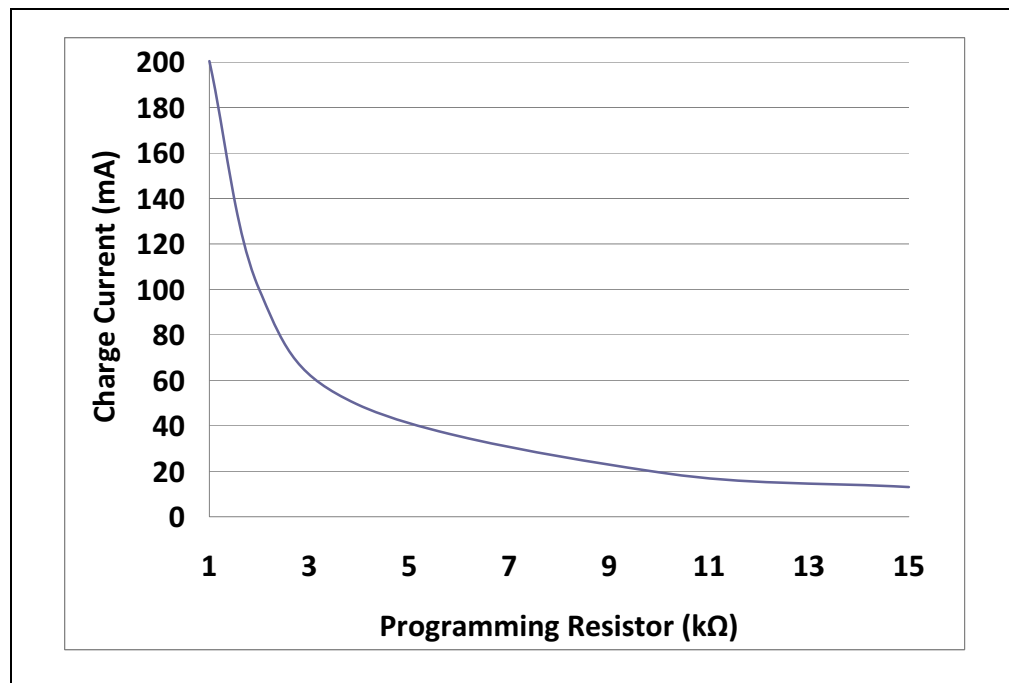

**FIGURE 1-1:** Resistor vs. Charge Current.



# MCP73830L 2X2 TDFN LI-ION BATTERY CHARGER EVALUATION BOARD USER'S GUIDE

---

---

## Appendix A. Schematic and Layouts

---

---

### A.1 INTRODUCTION

This appendix contains the following schematics and layouts for the MCP73830L 2x2 TDFN Li-Ion Battery Charger Evaluation Board:

- Board – Schematic
- Board – Top Layer
- Board – Top Copper Layer
- Board – Bottom Copper Layer

A.2 BOARD – SCHEMATIC

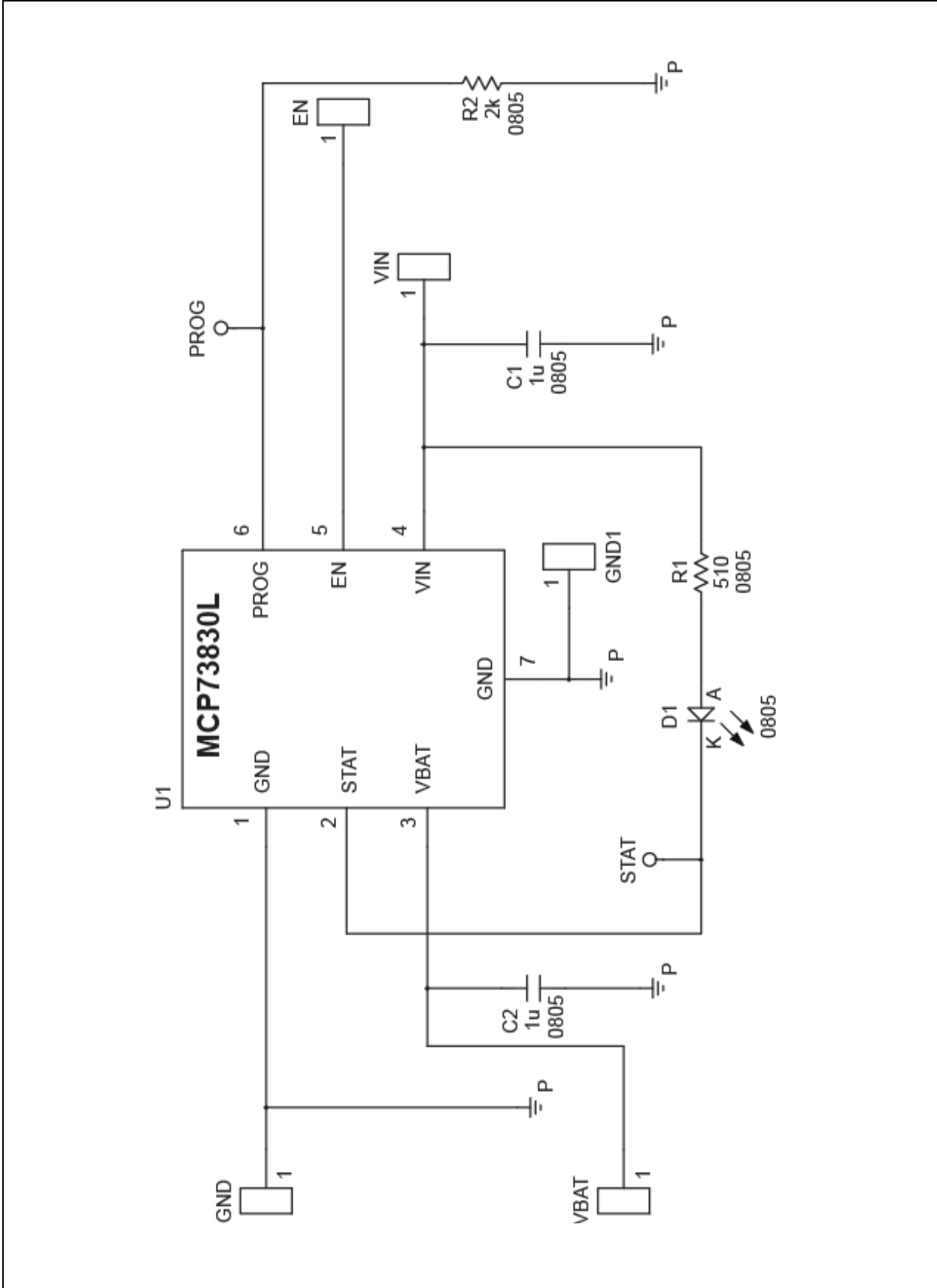

## A.3 BOARD – TOP LAYER

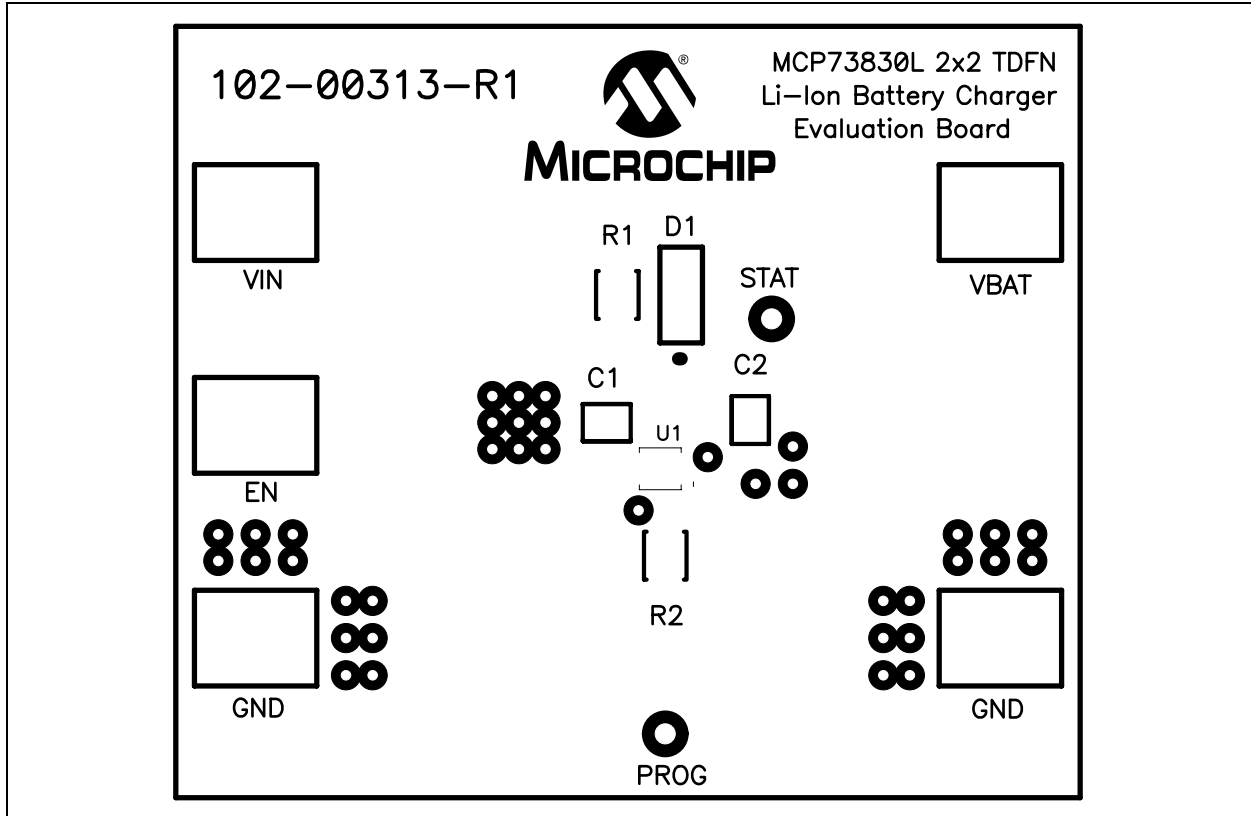

## A.4 BOARD – TOP COPPER

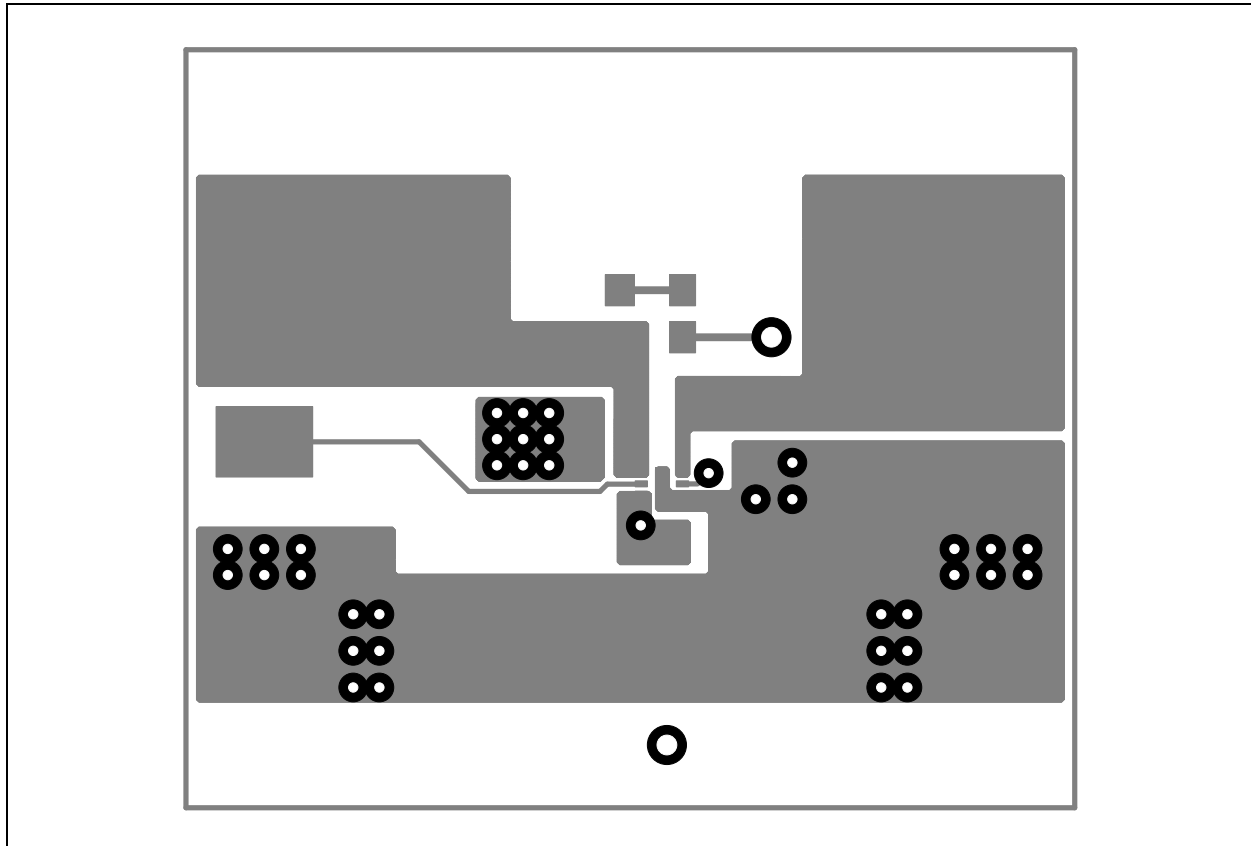

A.5 BOARD – BOTTOM COPPER

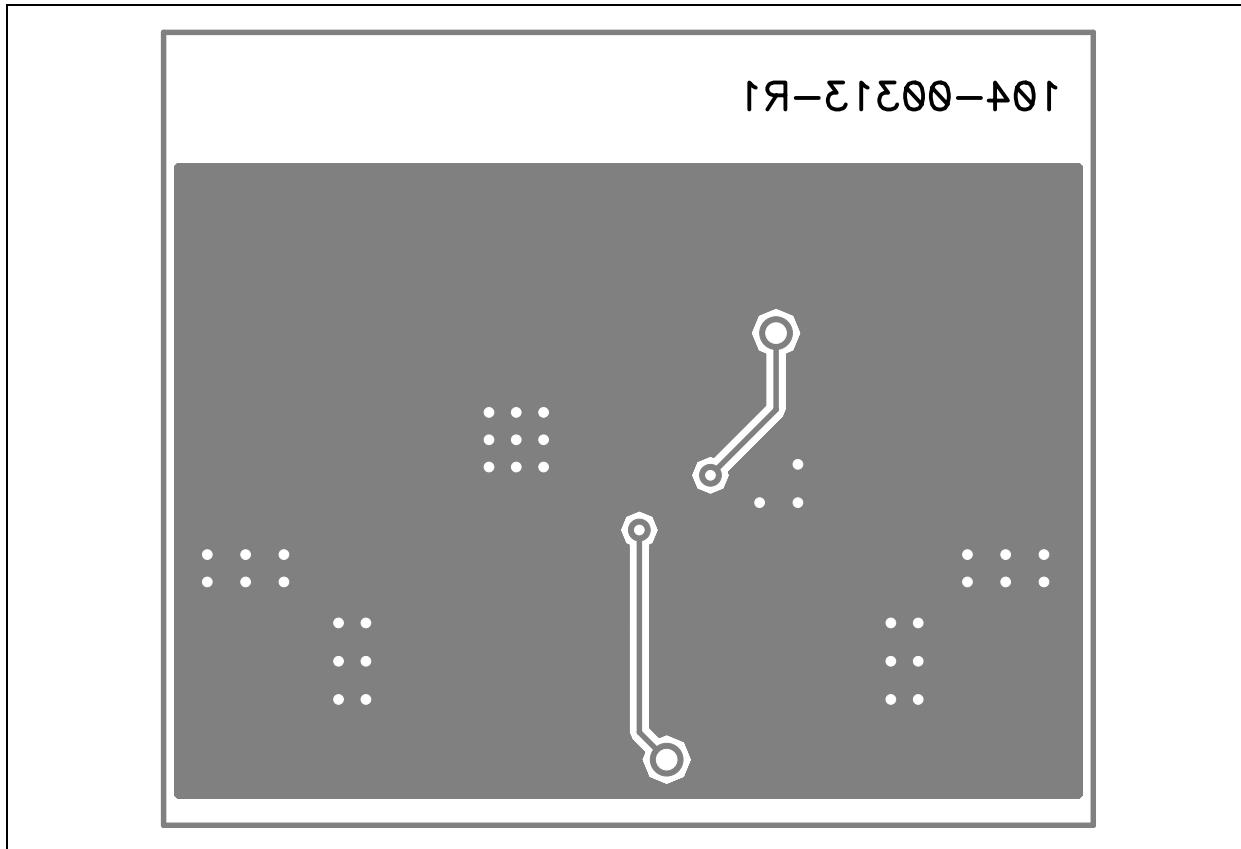





# MCP73830L 2X2 TDFN LI-ION BATTERY CHARGER EVALUATION BOARD USER'S GUIDE

## Appendix B. Bill of Materials

**TABLE B-1: BILL OF MATERIALS (BOM)**

Qty	Reference	Description	Manufacturer	Part Number
1	–	Printed circuit board	Microchip Technology Inc.	102-00313
2	C1,C2	CAP CER 1.0uF 10V 10% X5R 0805	Panasonic® - ECG	GRM219R61A105KC01D
1	D1	LED ALINGAP RED CLEAR 0805 SMD	Panasonic - ECG	598-8110-107F
1	R1	RES 510 OHM 1/8W 1% 0805 SMD	Panasonic - ECG	ERJ-6ENF5100V
1	R2	RES 2.00K OHM 1/8W 1% 0805 SMD	Panasonic - ECG	ERJ-6ENF2001V
1	U1	Single-Chip Linear Li-Ion Battery Charger	Microchip Technology Inc.	MCP73830L

**Note 1:** The components listed in this Bill of Materials are representative of the PCB assembly. The released BOM used in manufacturing uses all RoHS-compliant components.



# MICROCHIP

## Worldwide Sales and Service

### AMERICAS

**Corporate Office**  
2355 West Chandler Blvd.  
Chandler, AZ 85224-6199  
Tel: 480-792-7200  
Fax: 480-792-7277  
Technical Support:  
<http://www.microchip.com/support>  
Web Address:  
[www.microchip.com](http://www.microchip.com)

**Atlanta**  
Duluth, GA  
Tel: 678-957-9614  
Fax: 678-957-1455

**Boston**  
Westborough, MA  
Tel: 774-760-0087  
Fax: 774-760-0088

**Chicago**  
Itasca, IL  
Tel: 630-285-0071  
Fax: 630-285-0075

**Cleveland**  
Independence, OH  
Tel: 216-447-0464  
Fax: 216-447-0643

**Dallas**  
Addison, TX  
Tel: 972-818-7423  
Fax: 972-818-2924

**Detroit**  
Farmington Hills, MI  
Tel: 248-538-2250  
Fax: 248-538-2260

**Indianapolis**  
Noblesville, IN  
Tel: 317-773-8323  
Fax: 317-773-5453

**Los Angeles**  
Mission Viejo, CA  
Tel: 949-462-9523  
Fax: 949-462-9608

**Santa Clara**  
Santa Clara, CA  
Tel: 408-961-6444  
Fax: 408-961-6445

**Toronto**  
Mississauga, Ontario,  
Canada  
Tel: 905-673-0699  
Fax: 905-673-6509

### ASIA/PACIFIC

**Asia Pacific Office**  
Suites 3707-14, 37th Floor  
Tower 6, The Gateway  
Harbour City, Kowloon  
Hong Kong  
Tel: 852-2401-1200  
Fax: 852-2401-3431

**Australia - Sydney**  
Tel: 61-2-9868-6733  
Fax: 61-2-9868-6755

**China - Beijing**  
Tel: 86-10-8569-7000  
Fax: 86-10-8528-2104

**China - Chengdu**  
Tel: 86-28-8665-5511  
Fax: 86-28-8665-7889

**China - Chongqing**  
Tel: 86-23-8980-9588  
Fax: 86-23-8980-9500

**China - Hangzhou**  
Tel: 86-571-2819-3187  
Fax: 86-571-2819-3189

**China - Hong Kong SAR**  
Tel: 852-2401-1200  
Fax: 852-2401-3431

**China - Nanjing**  
Tel: 86-25-8473-2460  
Fax: 86-25-8473-2470

**China - Qingdao**  
Tel: 86-532-8502-7355  
Fax: 86-532-8502-7205

**China - Shanghai**  
Tel: 86-21-5407-5533  
Fax: 86-21-5407-5066

**China - Shenyang**  
Tel: 86-24-2334-2829  
Fax: 86-24-2334-2393

**China - Shenzhen**  
Tel: 86-755-8203-2660  
Fax: 86-755-8203-1760

**China - Wuhan**  
Tel: 86-27-5980-5300  
Fax: 86-27-5980-5118

**China - Xian**  
Tel: 86-29-8833-7252  
Fax: 86-29-8833-7256

**China - Xiamen**  
Tel: 86-592-2388138  
Fax: 86-592-2388130

**China - Zhuhai**  
Tel: 86-756-3210040  
Fax: 86-756-3210049

### ASIA/PACIFIC

**India - Bangalore**  
Tel: 91-80-3090-4444  
Fax: 91-80-3090-4123

**India - New Delhi**  
Tel: 91-11-4160-8631  
Fax: 91-11-4160-8632

**India - Pune**  
Tel: 91-20-2566-1512  
Fax: 91-20-2566-1513

**Japan - Yokohama**  
Tel: 81-45-471- 6166  
Fax: 81-45-471-6122

**Korea - Daegu**  
Tel: 82-53-744-4301  
Fax: 82-53-744-4302

**Korea - Seoul**  
Tel: 82-2-554-7200  
Fax: 82-2-558-5932 or  
82-2-558-5934

**Malaysia - Kuala Lumpur**  
Tel: 60-3-6201-9857  
Fax: 60-3-6201-9859

**Malaysia - Penang**  
Tel: 60-4-227-8870  
Fax: 60-4-227-4068

**Philippines - Manila**  
Tel: 63-2-634-9065  
Fax: 63-2-634-9069

**Singapore**  
Tel: 65-6334-8870  
Fax: 65-6334-8850

**Taiwan - Hsin Chu**  
Tel: 886-3-5778-366  
Fax: 886-3-5770-955

**Taiwan - Kaohsiung**  
Tel: 886-7-536-4818  
Fax: 886-7-330-9305

**Taiwan - Taipei**  
Tel: 886-2-2500-6610  
Fax: 886-2-2508-0102

**Thailand - Bangkok**  
Tel: 66-2-694-1351  
Fax: 66-2-694-1350

### EUROPE

**Austria - Wels**  
Tel: 43-7242-2244-39  
Fax: 43-7242-2244-393

**Denmark - Copenhagen**  
Tel: 45-4450-2828  
Fax: 45-4485-2829

**France - Paris**  
Tel: 33-1-69-53-63-20  
Fax: 33-1-69-30-90-79

**Germany - Munich**  
Tel: 49-89-627-144-0  
Fax: 49-89-627-144-44

**Italy - Milan**  
Tel: 39-0331-742611  
Fax: 39-0331-466781

**Netherlands - Drunen**  
Tel: 31-416-690399  
Fax: 31-416-690340

**Spain - Madrid**  
Tel: 34-91-708-08-90  
Fax: 34-91-708-08-91

**UK - Wokingham**  
Tel: 44-118-921-5869  
Fax: 44-118-921-5820

08/02/11