

REV.	DESCRIPTION	DATE	APPROVED
B	Engineering Release	07/15/15	J. C.
C	Added Color Options, Sheet #2	01/25/16	J. C.
D	Revised Color Table, Sheet #2	07/02/18	G. O.

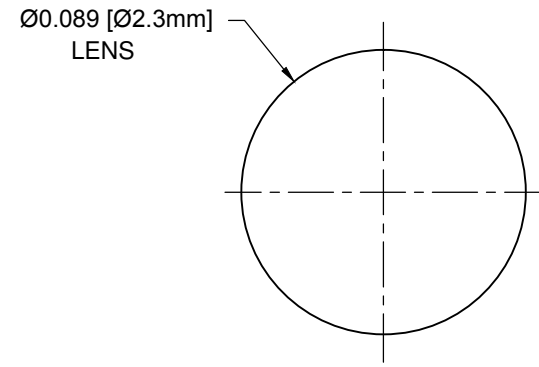

BODY LENGTHS FOR CLEAR LIGHT PIPES.

Part No.	X = Body Length
PLPC2-100	0.100 (2.5mm)
PLPC2-125	0.125 (3.2mm)
PLPC2-188	0.188 (4.8mm)
PLPC2-250	0.250 (6.4mm)
PLPC2-313	0.313 (7.9mm)
PLPC2-375	0.375 (9.5mm)
PLPC2-500	0.500 (12.7mm)
PLPC2-3MM	3mm (0.118")
PLPC2-4MM	4mm (0.157")
PLPC2-5MM	5mm (0.197")
PLPC2-6MM	6mm (0.236")
PLPC2-7MM	7mm (0.276")
PLPC2-8MM	8mm (0.315")
PLPC2-9MM	9mm (0.354")
PLPC2-10MM	10mm (0.394")

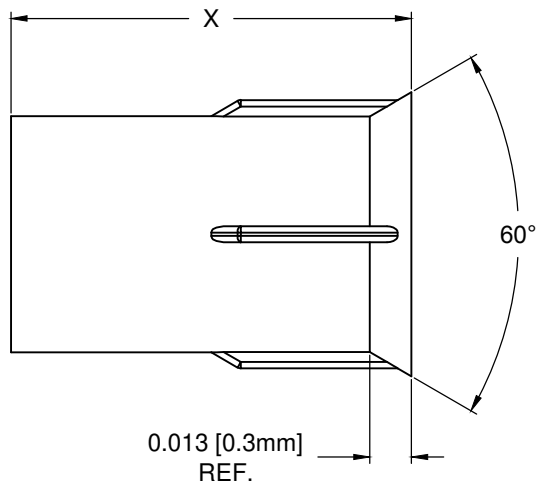
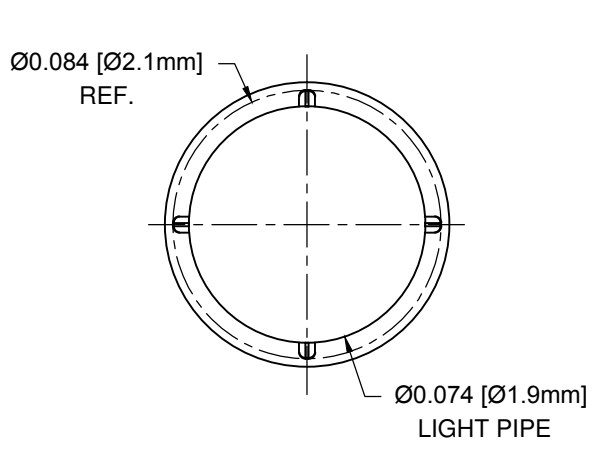
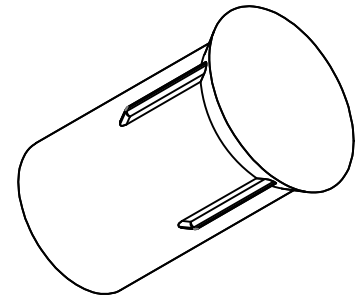
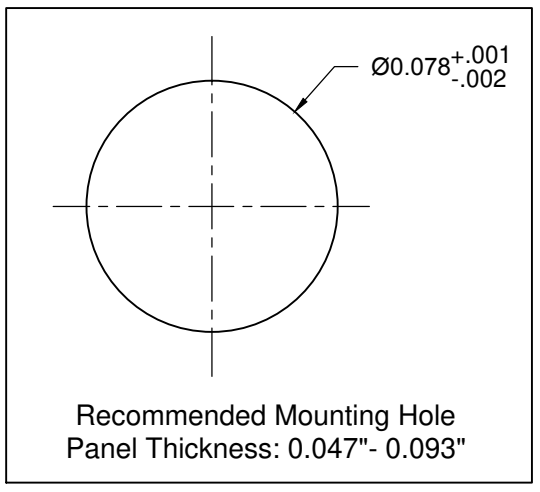

- 2. MATERIAL: POLYCARBONATE, 94V-0, CLEAR.
- 1. GENERAL SPECIFICATIONS: BIVAR MOLDED COMPONENT SPECIFICATION BV00-E101 and BSMC-1001.

STANDARD TOLERANCE (UNLESS OTHERWISE SPECIFIED)		 BIVAR [®] 4 THOMAS, IRVINE, CA. 92618 TEL: (949) 951-8808 FAX: (949) 951-3974			
DECIMALS	ANGULAR				
.X ± .1	X° ± 1°	TITLE: PRESS FIT, PANEL MOUNT LIGHT PIPE, FLUSH, 2mm REVISION: D			
.XX ± .01					
.XXX ± .005		DESIGNED: A. WRIGHT	DATE: 4/24/15	PART NO: PLPC2-XXX	REVISION: D
		REVISOR: TD. NGUYEN	DATE: 7/2/18	CAGE CODE: 32559	
		CHECKED: K. BARON	DATE: 7/2/18	SCALE: NONE	SHEET # 1 OF 2
CAD GENERATED DOCUMENT, DO NOT MEASURE DRAWING					

OTHER AVAILABLE COLORS
 * SEE TABLE FOR ORDERING INFORMATION

REV.	DESCRIPTION	DATE	APPROVED
	SEE SHEET #1		

AVAILABLE COLOR OPTIONS

PLPC2 - -

RIGID LIGHT PIPE
SERIES

LENGTH

PART NUMBER	BODY LENGTH
PLPC2-100	0.100" (2.5mm)
PLPC2-125	0.125" (3.2mm)
PLPC2-2.5mm	2.5mm (0.100")
PLPC2-3mm	3mm (0.118")

COLOR	Order Code
TINTED BLUE	BE
TINTED GREEN	GN
TINTED RED	RD
TINTED YELLOW	YW

PLPC2 - -

RIGID LIGHT PIPE
SERIES

LENGTH

PART NUMBER	BODY LENGTH
PLPC2-100	0.100" (2.5mm)
PLPC2-125	0.125" (3.2mm)
PLPC2-2.5mm	2.5mm (0.100")
PLPC2-3mm	3mm (0.118")

COLOR	Order Code
DIFFUSED	D
SMOKED	S