

PART NUMBER	REVISION	DESCRIPTION	FEED TYPE
2151501-2	K	FINE CRIMP HEIGHT ADJUST	PNEUMATIC
7-2151501-2	K	PNEUMATIC AND CRIMP TOOLING KIT	PNEUMATIC
7-2151501-7	G	CRIMP TOOLING KIT	-

ATLANTIC VERSION TERMINATOR INTERFACE ADAPTER

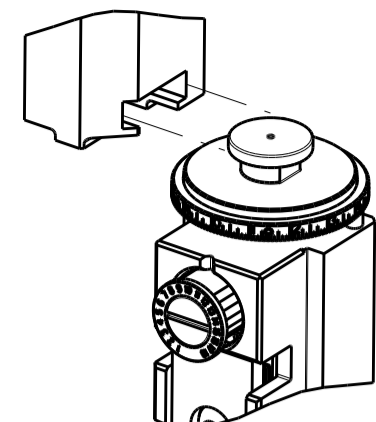

APPLICATOR DATA		
CRIMP	SIZE	TYPE
WIRE	3.30 mm [.130]	F
INSUL	6.60 mm [.260]	O

APPLICATOR INSTRUCTIONS 408-35042

TERMINAL DATA: TE TERMINAL		TE CRIMP SPECIFICATION	
TERMINAL NAME: TAB 5.8 X 0.8 ASSEMBLY			
WIRE STRIP LENGTH	5.05-6.05 mm [.199-.238 IN]	TERMINAL INSULATION DIAMETER RANGE	∅
TERMINAL APPLICATION SPECIFICATION	114-18052		

TERMINALS APPLIED				SEAL INSULATION DIAMETER RANGE
TE TERMINAL	TE TERMINAL	TE SEAL	TE SEAL	
964314-1	2-964314-2		963245-1	∅ 3.40-3.70mm

WIRE SIZE	CRIMP HEIGHT mm [INCH]	CRIMP HEIGHT REFERENCE SETTING
4.00mm2	2.34+/-0.05 [.092+/- .002]	8.2

- 1 RECOMMENDED SPARE PARTS
- 2 REFER TO SUPPLIED INSTRUCTION SHEET FOR CLEANING, LUBRICATION AND STORAGE OF APPLICATOR.
- 3 APPLY PART NUMBER 2-23419-6 LOCTITE TO THREADS OF ITEM 242.
- 4 CRIMP HEIGHT REFERENCE SETTING WAS THE SETTING USED WHEN THE APPLICATOR WAS QUALIFIED AT THE FACTORY. ADJUSTMENT MAY BE NECESSARY WHEN RUNNING APPLICATOR IN THE FIELD.
- 5. UNLESS SPECIFIED OTHERWISE TORQUE VALUES SHALL BE USED PER DOCUMENT, 101-35000.
- 6 TERMINAL PITCH NOT COMPATIBLE WITH MECHANICAL FEED.
- 7 APPLY TORO-SEAL IN ALLEN SOCKET TO FILL HOLE AFTER FLAT HD HAS BEEN ADJUSTED TO CORRECT HEIGHT AT QUALIFICATION. APPLY #1-23419-5 LOC-TITE TO THREADS.

**\*WARNING**  
ON INSTALLATION, SET WIRE DISC TO CRIMP HEIGHT REFERENCE SETTING FOR LARGEST WIRE SIZE. CRIMP HEIGHT REFERENCE SETTINGS GREATER THAN THE VALUE SHOWN MAY CAUSE DAMAGE TO THE CRIMP TOOLING, REFER TO THE INSTRUCTION SHEET FOR PROPER SETUP AND ADJUSTMENTS.

LOC	DIST	REVISIONS			
A	66	REV	DATE	BY	APPV
		H	15AUG2016	MR	GB
		H1	27JUL2018	FL	CT
		J	29OCT2018	FL	TE
		K	12JUN2019	FJ	TE

-	1	1	2119641-1	FEED CAM, AIR FEED	248	
-	1	1	2119082-6	CAM, SNAIL, INSULATION ADJUSTMENT	244	
-	1	1	2079764-1	WASHER, WAVE SPRING, CREST-TO-CREST	243	
-	1	1	2119083-1	RETAINER, INSULATION DIAL	242	
-	1	1	7-18023-7	SCR, SKT HD CAP M3 X 4.0	241	
-	1	1	2844940-2	AIR FEED MODULE	238	
-	REF	REF	994970-2	COUNTER, MAGNETIC	164	
-	1	1	2844908-1	SCREW, LOCKING	99	
-	1	1	2844907-1	POST, LOCKING	98	
-	1	1	1-690438-0	FRONT STRIP GUIDE	96	
-	1	1	455888-8	SPACER, CRIMPER	82	
-	1	1	1803607-3	DOCUMENTATION PACKAGE	71	
-	1	1	2119791-5	DEPRESSOR, WIRE	70	
-	1	1	2119943-1	WASHER, SPACER	69	
-	1	1	2119740-1	TAG IDENTIFICATION	67	
-	2	2	2168078-1	SCREW, DRIVE, RH, RoHS, 2 x .188	66	
-	1	1	2168083-2	SCR, SKT HD CAP, RoHS, M4 X 8.0	60	
-	1	1	5-18022-5	SCR, HEX HD CAP, M4 X 6.0	59	
-	1	1	985575-5	SCR, FLT SKT HD CAP M3 X 16.0	57	
-	1	1	1338683-8	FEED PAWL	56	
-	4	4	2168083-3	SCR, SKT HD CAP, RoHS, M4 X 12.0	54	
-	2	2	1-2168083-0	SCR, SKT HD CAP, RoHS, M4 X 10	53	
-	1	1	1803382-2	HOLD DOWN, SPRING LOADED	50	
-	1	1	18023-9	SCR, SKT HD CAP M4 X 6.0	49	
-	1	1	1803583-3	APPLICATOR BASIC ASSEMBLY, SF	46	
-	1	1	1803515-1	RAM ASSEMBLY, SF ATLANTIC	44	
-	1	1	1803602-1	SCR, BHSC, RoHS (M8 X 25)	41	
-	1	1	1-1752356-1	SUPPORT, TERMINAL	34	
-	2	2	2079383-5	SCR, BHSC, RoHS (M4 X 20)	33	
-	2	2	3-2844962-5	SPACER, CYLINDRICAL, STRIP GUIDE	30	
-	1	1	2844992-6	ASSEMBLY, STRIP GUIDE	29	
-	1	1	455888-4	SPACER, CRIMPER	28	
-	2	2	22283-1	SPRING, COMPRESSION	27	
-	1	1	240792-1	DRAG, TERMINAL	25	
-	1	1	1320928-6	STRIP GUIDE	24	
-	1	1	2168083-2	SCR, SKT HD CAP, RoHS, M4 X 8.0	21	
-	2	2	1-18028-2	WASHER, FLAT, REG M4	20	
-	1	1	2119533-1	STRIPPER, SIDE FEED	19	
-	1	1	2119806-1	INSERT, SHEAR	13	
-	1	1	3-22280-3	SPRING, COMPRESSION	12	
-	1	1	1-356885-3	STOP, SHEAR	11	
-	1	1	2119805-2	SHEAR HOLDER, FRONT	10	
-	1	1	318059-4	FLOATING SHEAR, FRONT	9	
-	1	2	1	2-1333229-7	ANVIL, COMBINATION	8
-	-	-	-	-	7	
-	-	-	-	-	6	
-	1	1	2-2119781-6	DEPRESSOR, SHEAR	5	
-	1	1	238011-2	BLOCK, CRIMPER SPACER	4	
-	1	2	1	5-1803018-6	CRIMPER, INSULATION O	3
-	-	-	-	-	2	
-	1	2	1	1-456410-7	CRIMPER, WIRE PREMIUM	1

ATLANTIC VERSION  
Shown on sheets 1 of 4 & 2 of 4  
(Pacific version shown on sheets 3 of 4 & 4 of 4)

DIMENSIONS:		TOLERANCES UNLESS OTHERWISE SPECIFIED:		MATERIAL:		FINISH:	
mm	0 PLC ±	1 PLC ±	2 PLC ±	3 PLC ±	4 PLC ±	ANGLES ±	

OWN	C. CHEN	29AUG2012	TE Connectivity
CHK	S. XI	29AUG2012	Harrisburg, PA 17105-3608
APPV	J. CRUZ	29AUG2012	
PRODUCT SPEC	Ocean Side Feed Applicator		
APPLICATION SPEC			
SIZE	CAGE CODE	DRAWING NO	RESTRICTED TO
A1	00779	2151501	
CUSTOMER DRAWING			SCALE 1:2 SHEET 1 OF 4 REV K

LOC	DIST	REVISIONS					
A	66	P	LTN	DESCRIPTION	DATE	DMN	APVD
		-		SEE SHEET 1	-	-	-

# FEED TYPE

## PNEUMATIC

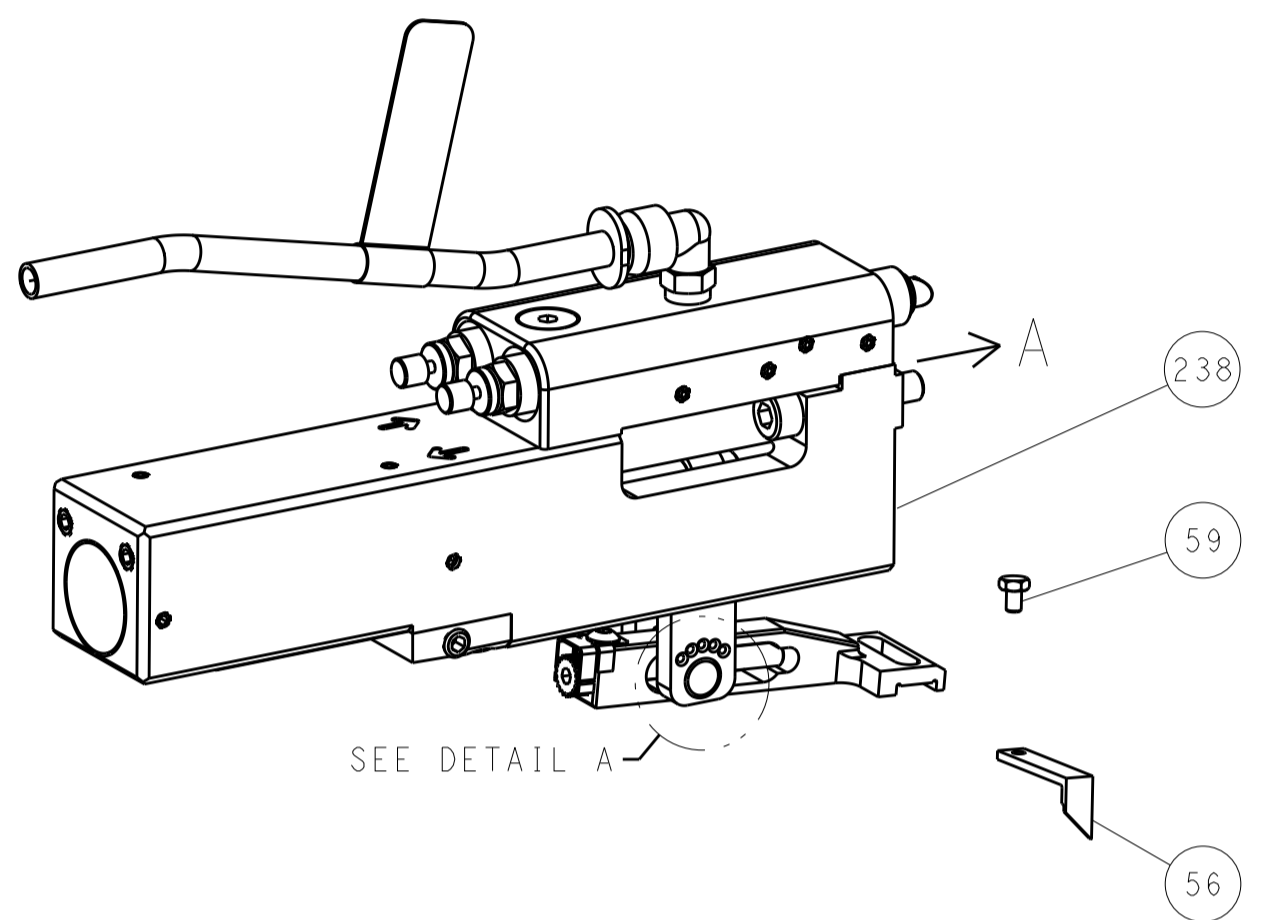

## FEED SPRING SETTING POSITION (SHOWN FROM REAR SIDE)

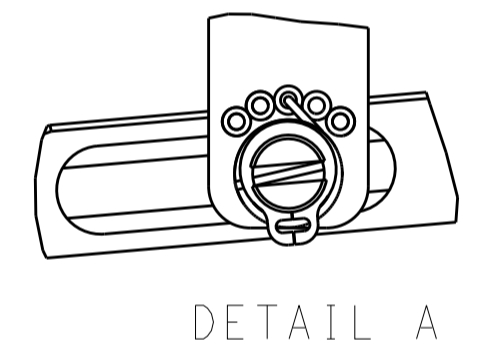

DETAIL A

## CAM POSITION

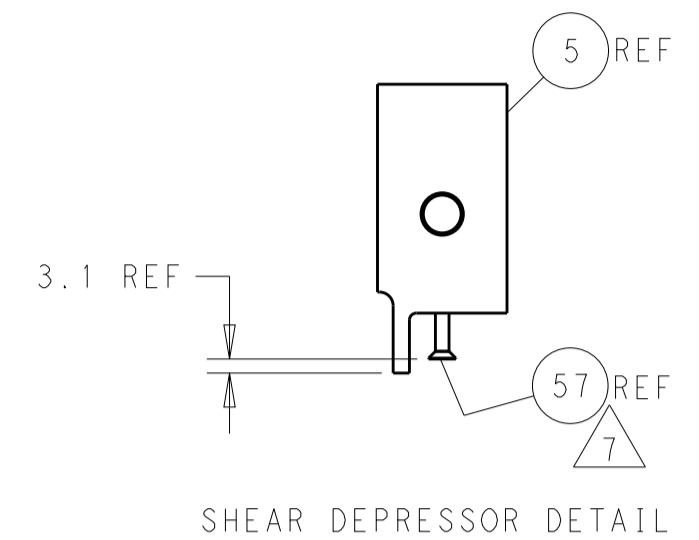
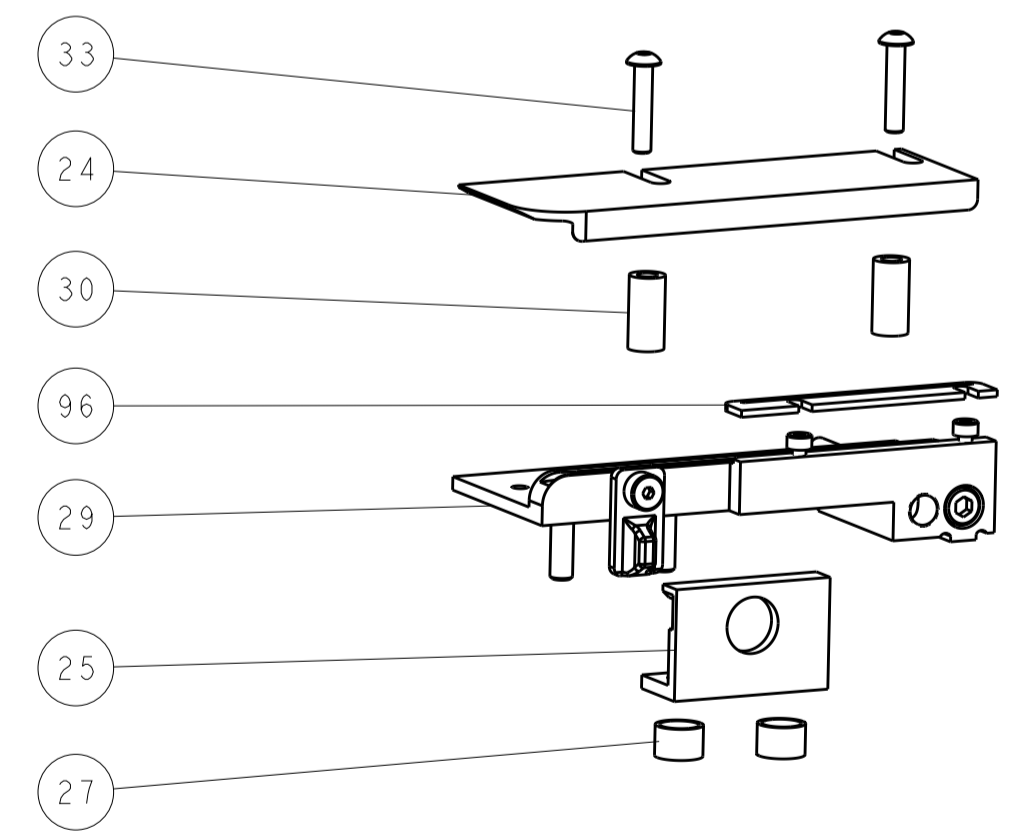
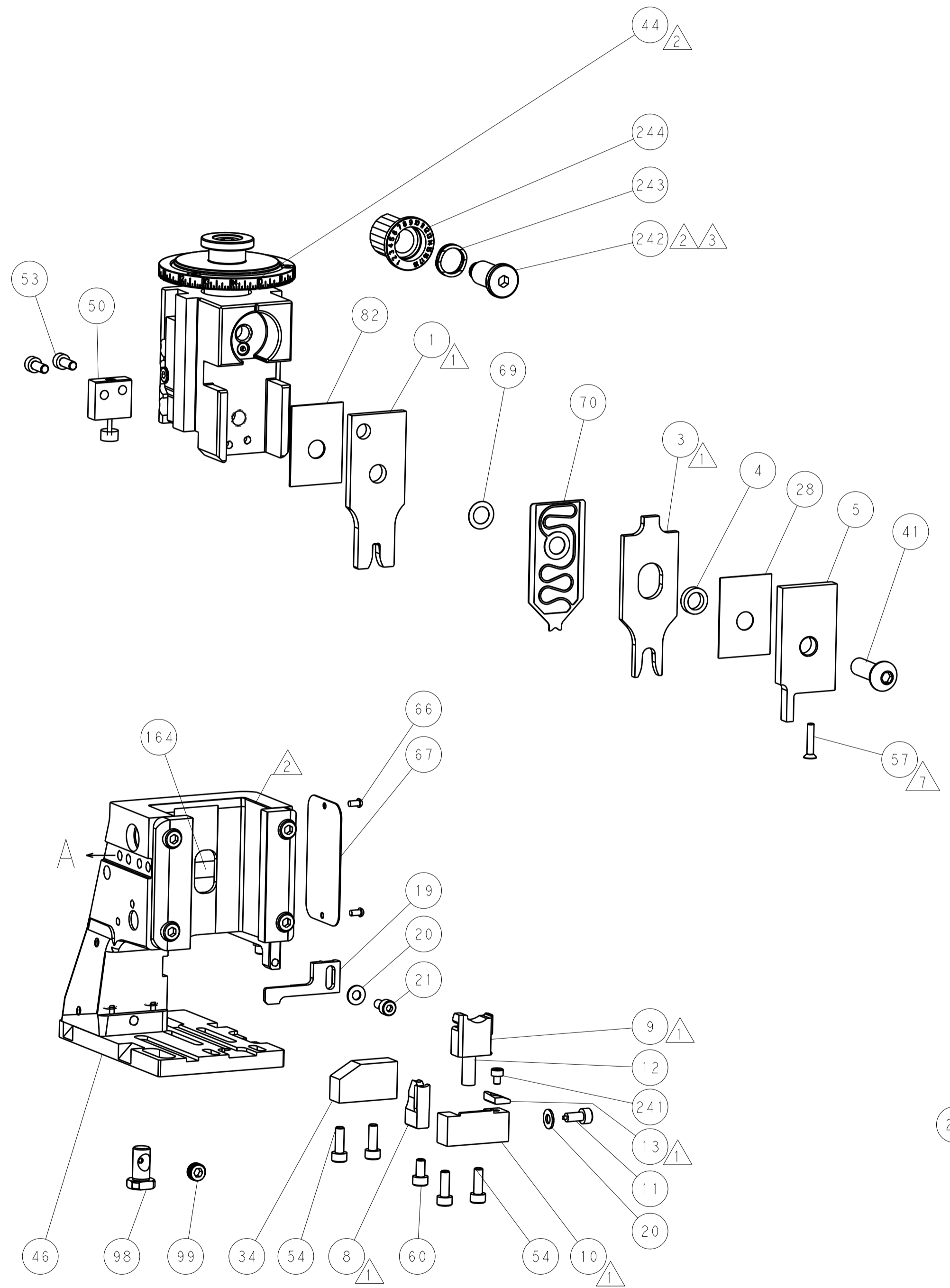
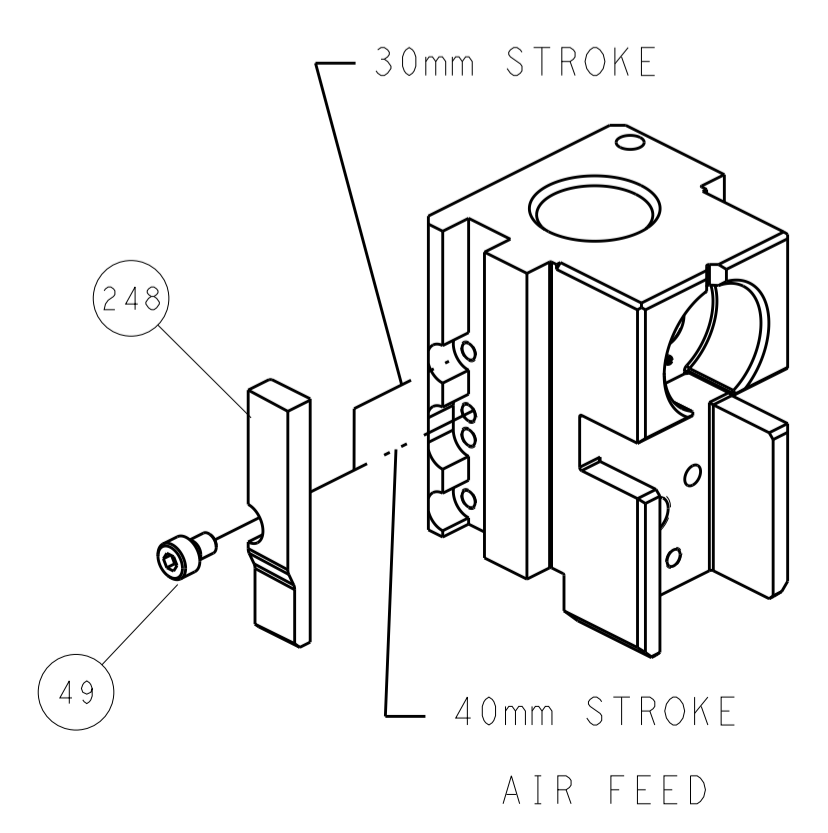

SHEAR DEPRESSOR DETAIL

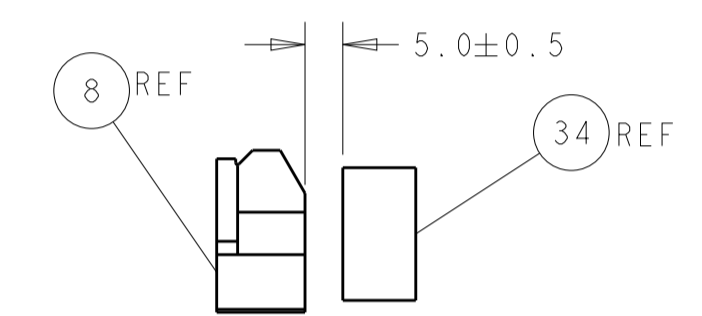

TERMINAL SUPPORT LOCATION

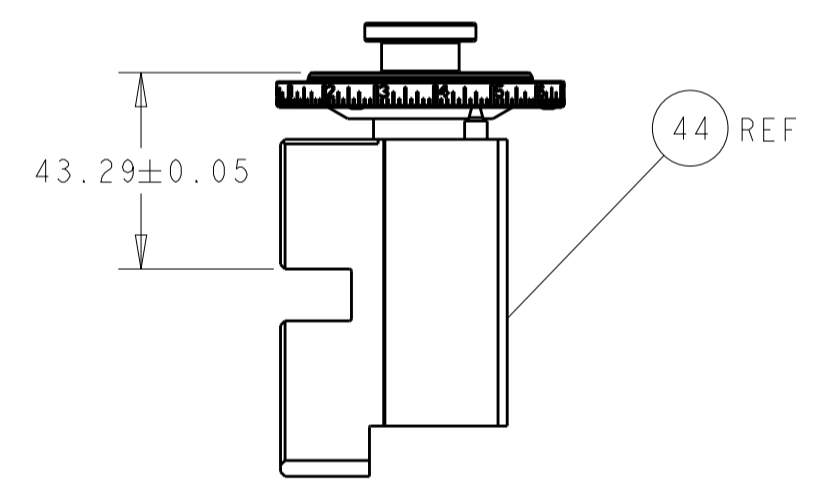

RAM SET-UP

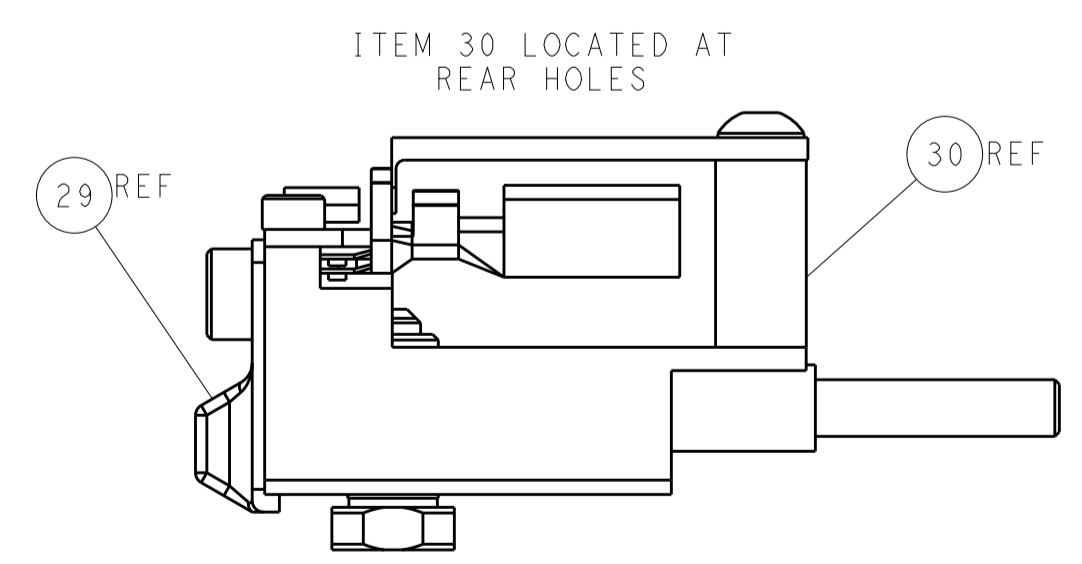

FEED TRACK POSITION GUIDE BY INSULATION BARREL

**ATLANTIC VERSION**  
 Shown on sheets 1 of 4 & 2 of 4  
 (Pacific version shown on sheets 3 of 4 & 4 of 4)

DIMENSIONS:		TOLERANCES UNLESS OTHERWISE SPECIFIED:		DMN	29AUG2012	TE Connectivity Harrisburg, PA 17105-3608
mm	0 PLC ±	1 PLC ±	2 PLC ±	CHK	29AUG2012	
	3 PLC ±	4 PLC ±	5 PLC ±	APVD	29AUG2012	NAME
	6 PLC ±	7 PLC ±	8 PLC ±			Ocean Side Feed
	9 PLC ±	10 PLC ±	11 PLC ±			Applicator
	12 PLC ±	13 PLC ±	14 PLC ±			
	15 PLC ±	16 PLC ±	17 PLC ±			
	18 PLC ±	19 PLC ±	20 PLC ±			
MATERIAL	FINISH	WEIGHT	SCALE	SIZE	CAGE CODE	DRAWING NO.
			1:2	A1	00779	2151501
CUSTOMER DRAWING		SCALE		SHEET		REV
		1:2		2 of 4		K



LOC	DIST	REV	DATE	BY	APP'D
A	66				

# FEED TYPE

## PNEUMATIC

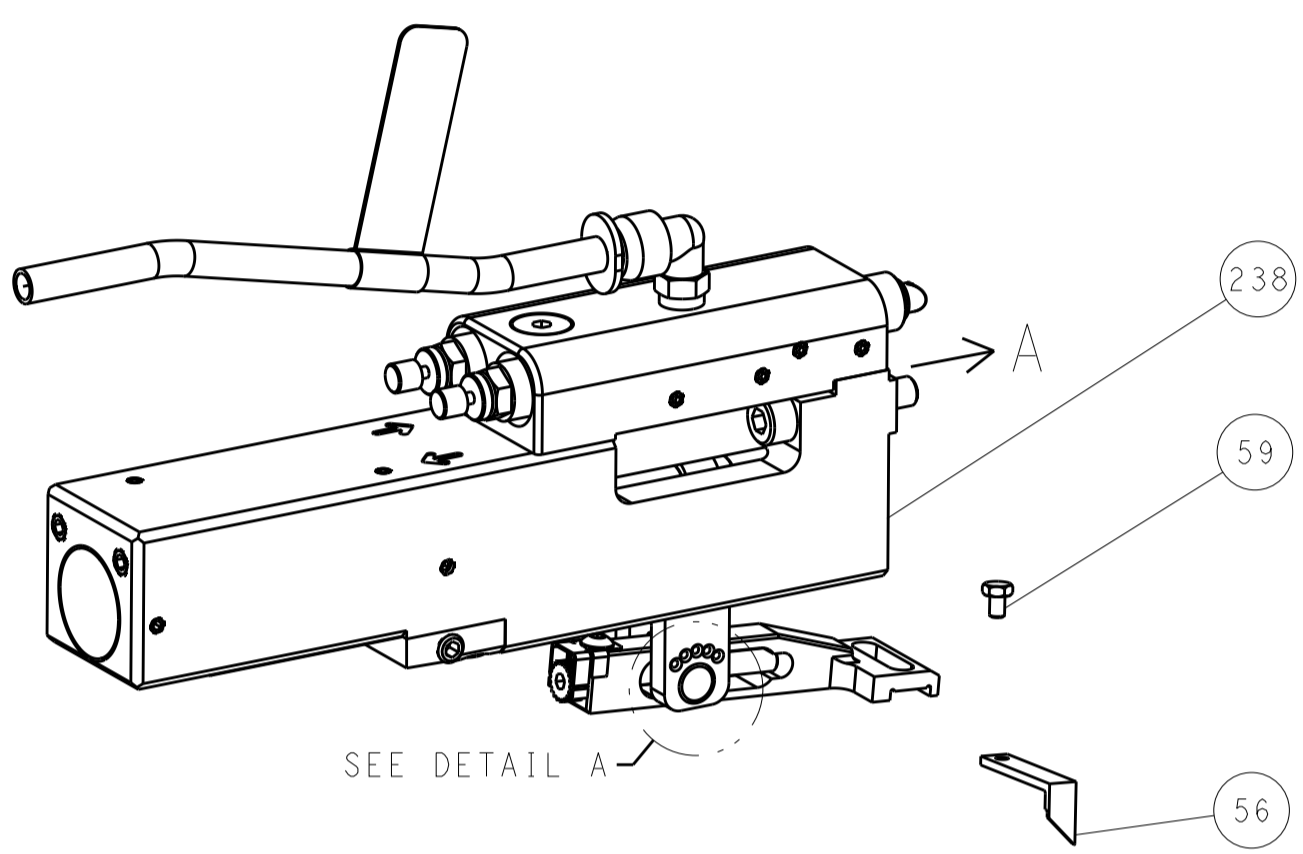

## FEED SPRING SETTING POSITION (SHOWN FROM REAR SIDE)

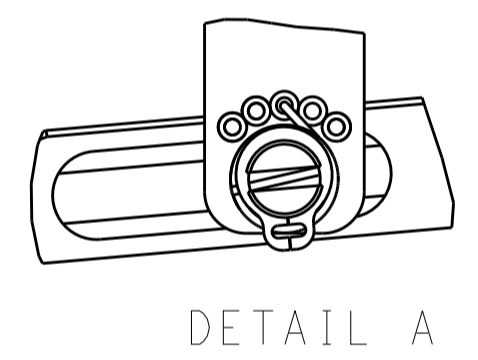

DETAIL A

## CAM POSITION

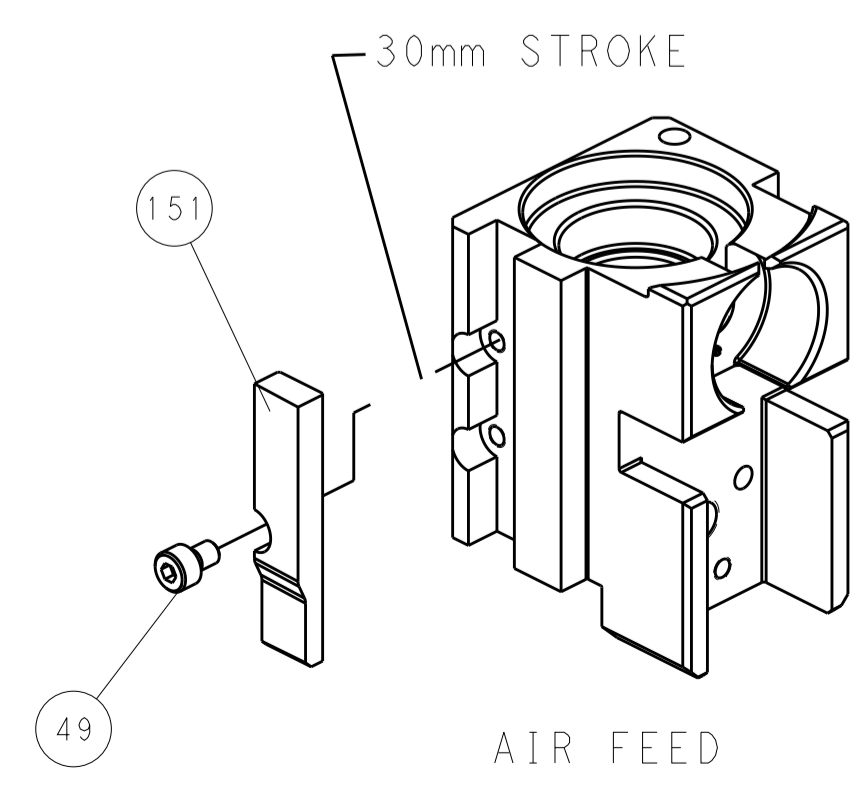

AIR FEED

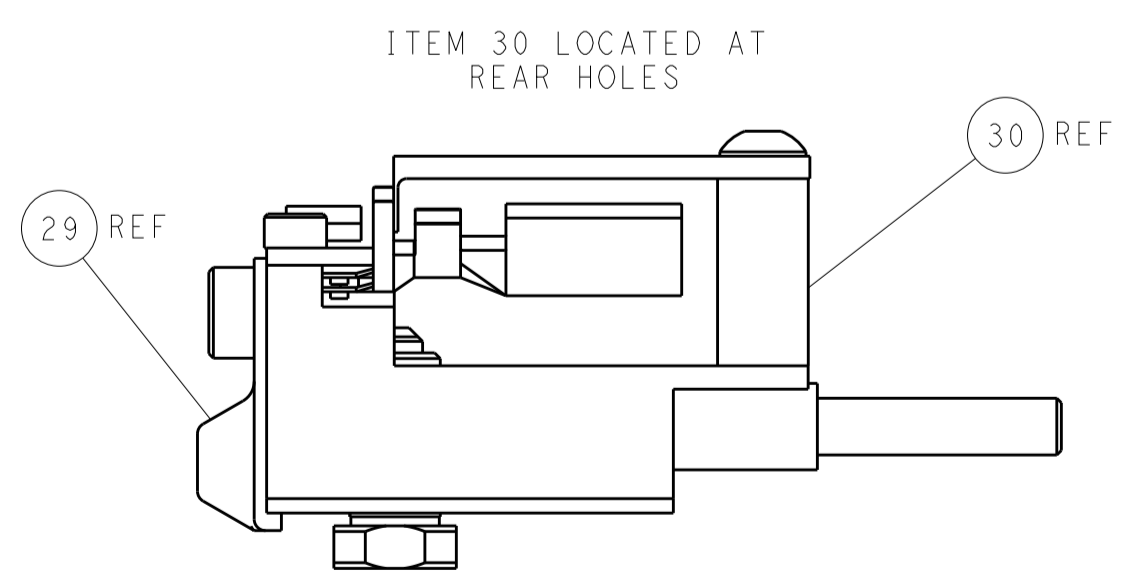
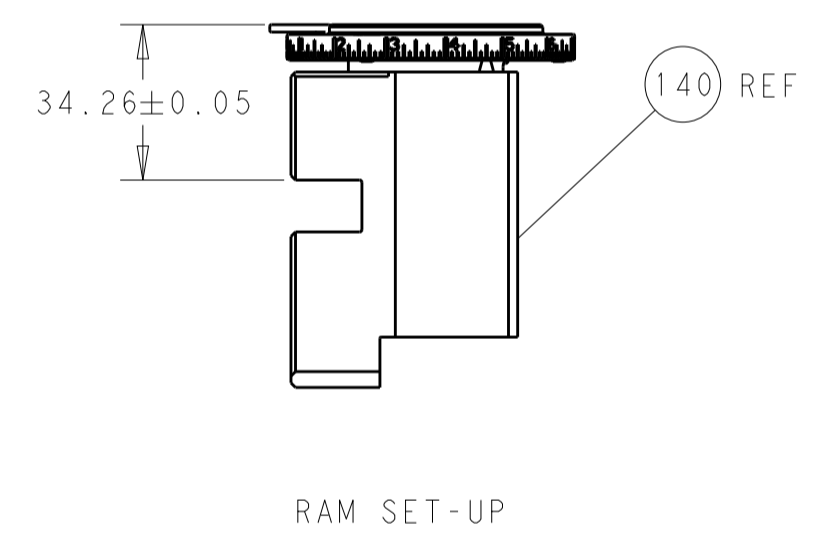
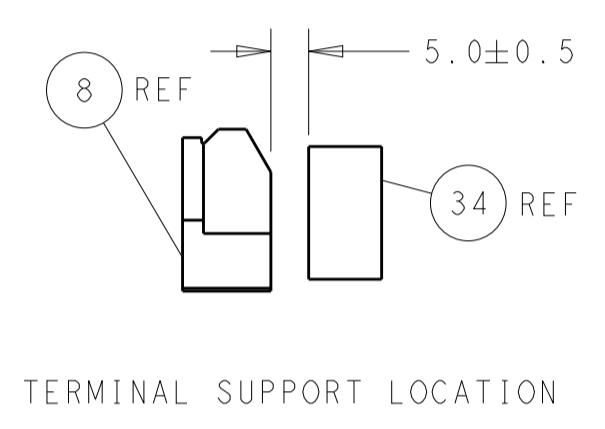
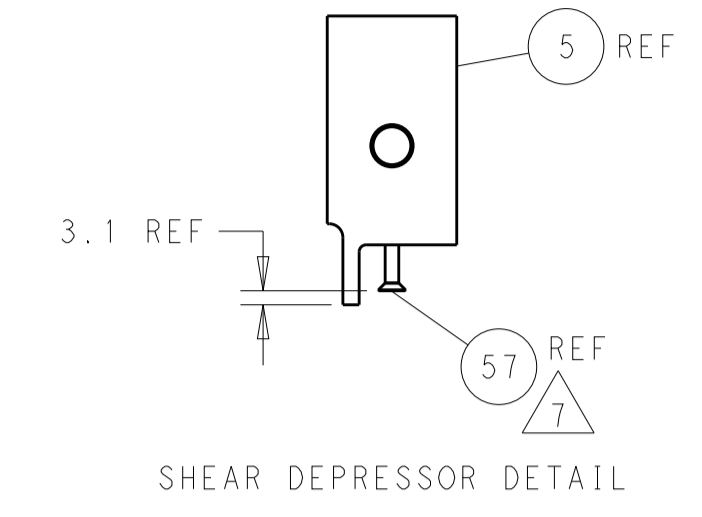
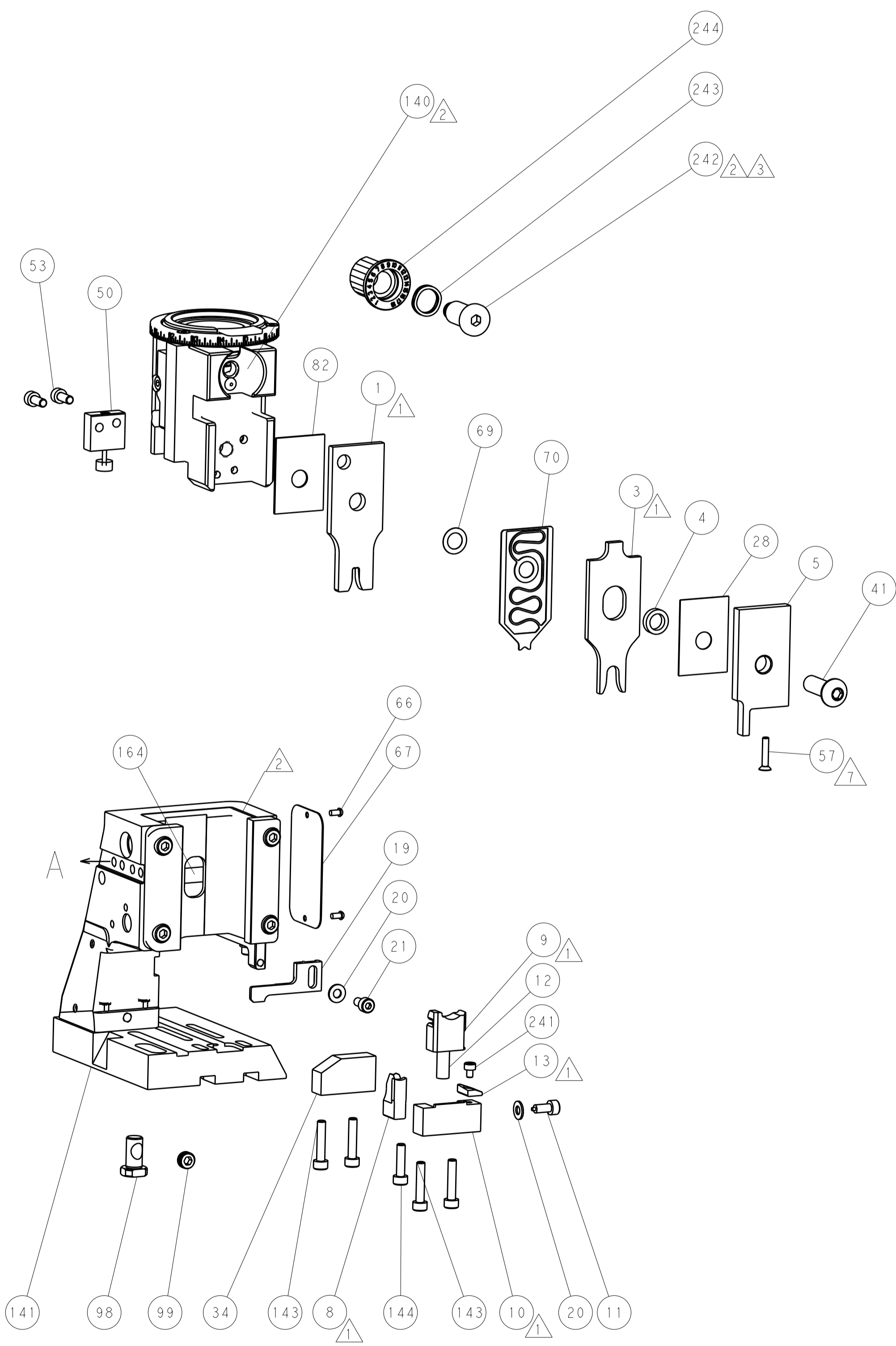
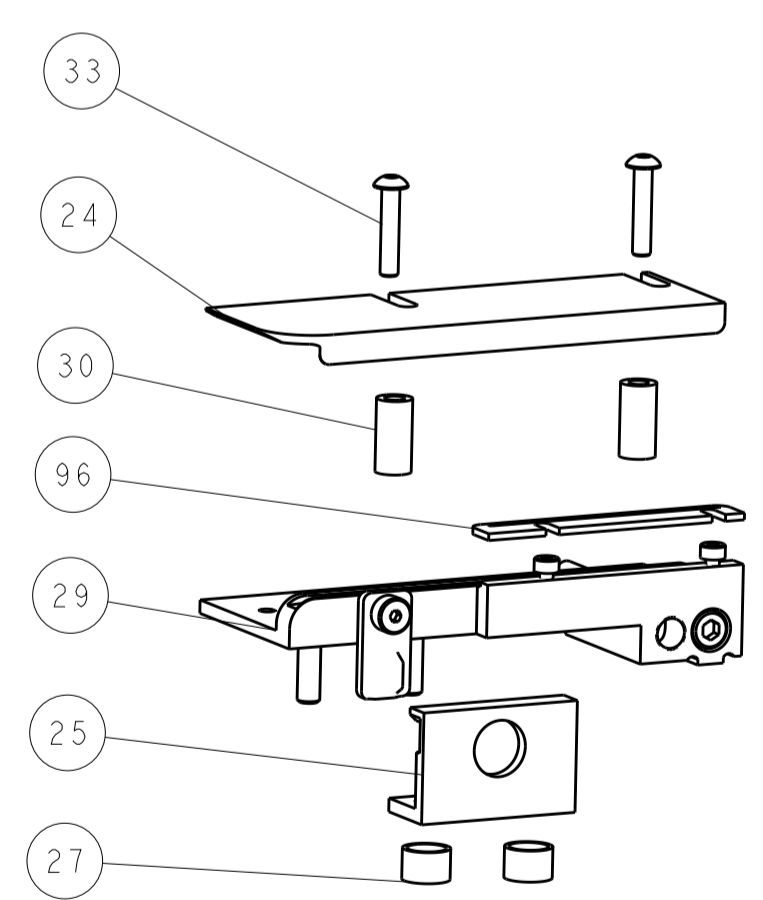

**PACIFIC VERSION**  
 Shown on sheets 3 of 4 & 4 of 4  
 (Atlantic version shown on sheets 1 of 4 & 2 of 4)

DIMENSIONS: mm 		TOLERANCES UNLESS OTHERWISE SPECIFIED: 0 PLC ± 1 PLC ± 2 PLC ± 3 PLC ± 4 PLC ± ANGLES ±		DWN: C. CHEN 29AUG2012 CHK: S. XI 29AUG2012 APVD: J. CRUZ 29AUG2012		NAME: Ocean Side Feed Applicator SIZE: A1 CAGE CODE: 00779 DRAWING NO: 2151501		RESTRICTED TO: K	
MATERIAL: -		FINISH: -		WEIGHT: -		SCALE: 1:2		SHEET 4 OF 4	
CUSTOMER DRAWING									