

LOC	DIST	REV	DATE	BY	CHK	APPV
GE	00	E1	26APR2011	RK	HMR	

REVISIONS

△ MATERIAL: 0.30 THICK COPPER ALLOY, PREPLATED WITH 0.0008 MINIMUM THICK REFLOW TIN OR BRIGHT TIN (ELV COMPLIANT).
 ALTERNATE MATERIAL: 0.30 THICK COPPER ALLOY, PREPLATED WITH 0.0008 MINIMUM THICK BRIGHT TIN (ELV COMPLIANT).

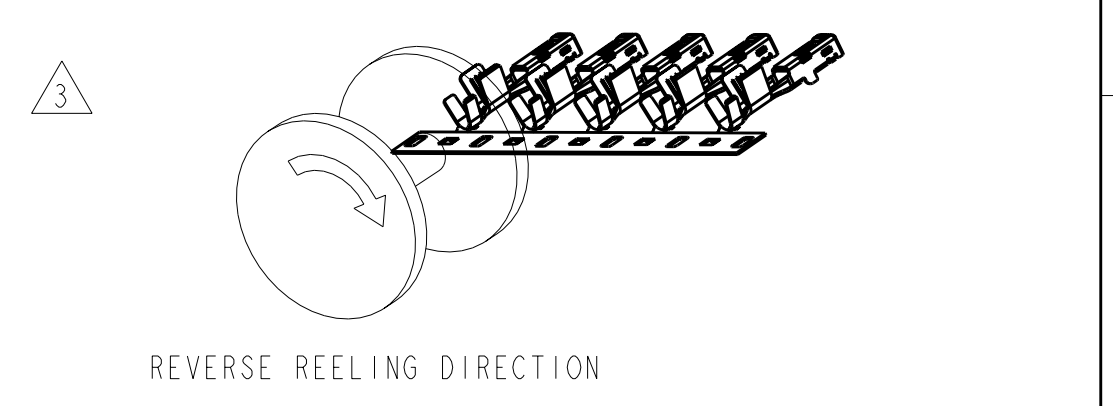
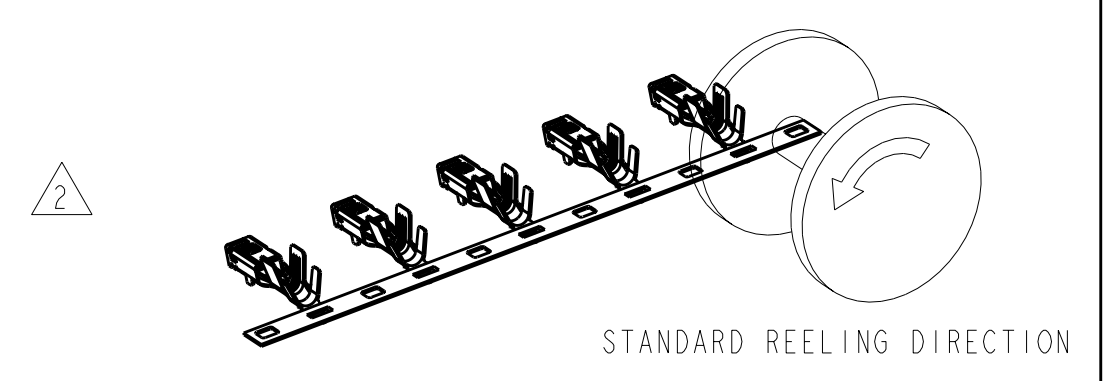
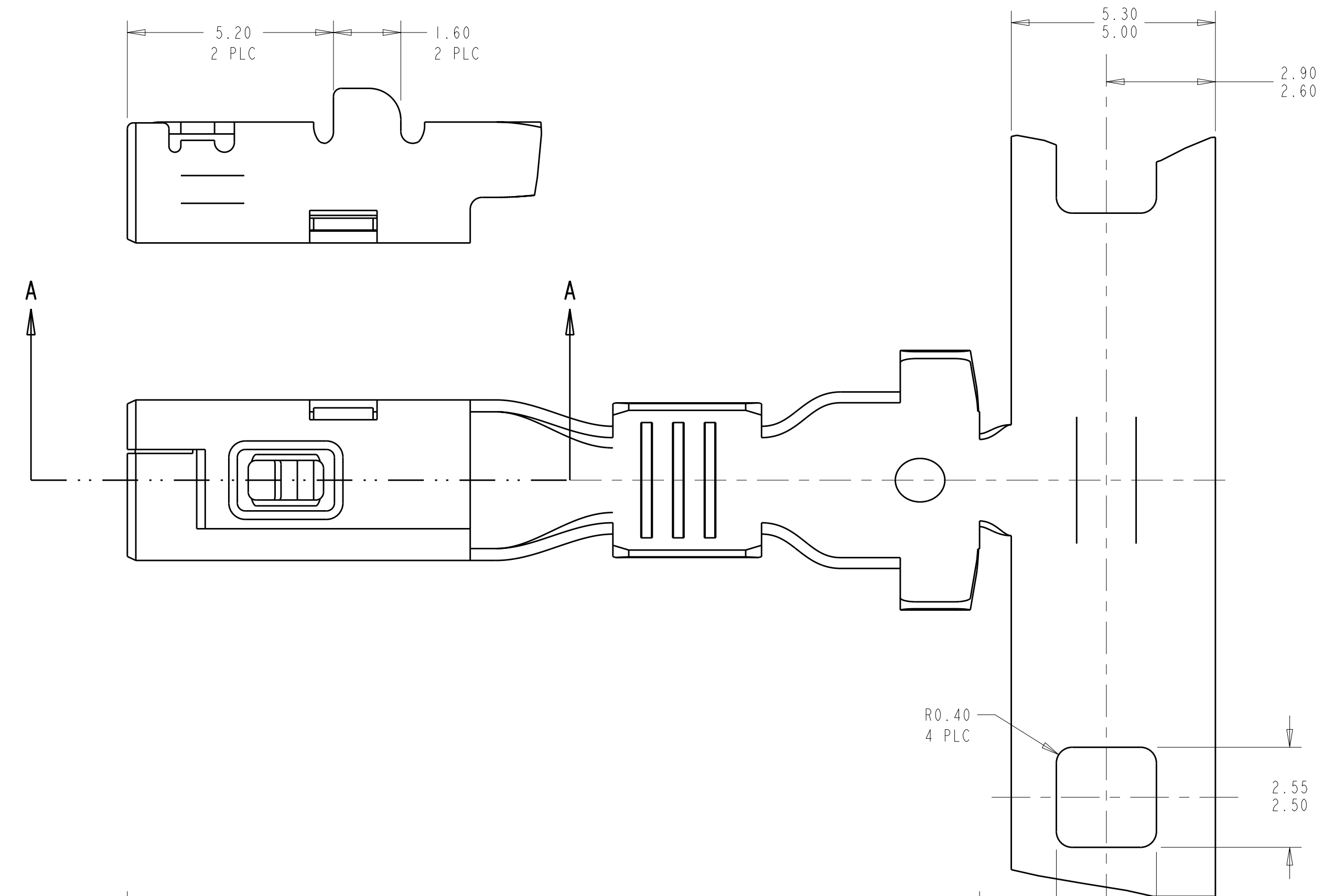

4. QUALIFICATION OF THE CRIMP APPLICATION TOOLING SHALL BE CONTROLLED BY THE REQUIREMENTS ESTABLISHED UNDER USCAR 21.
 5. LOOSE END SPLICING TO BE USED.

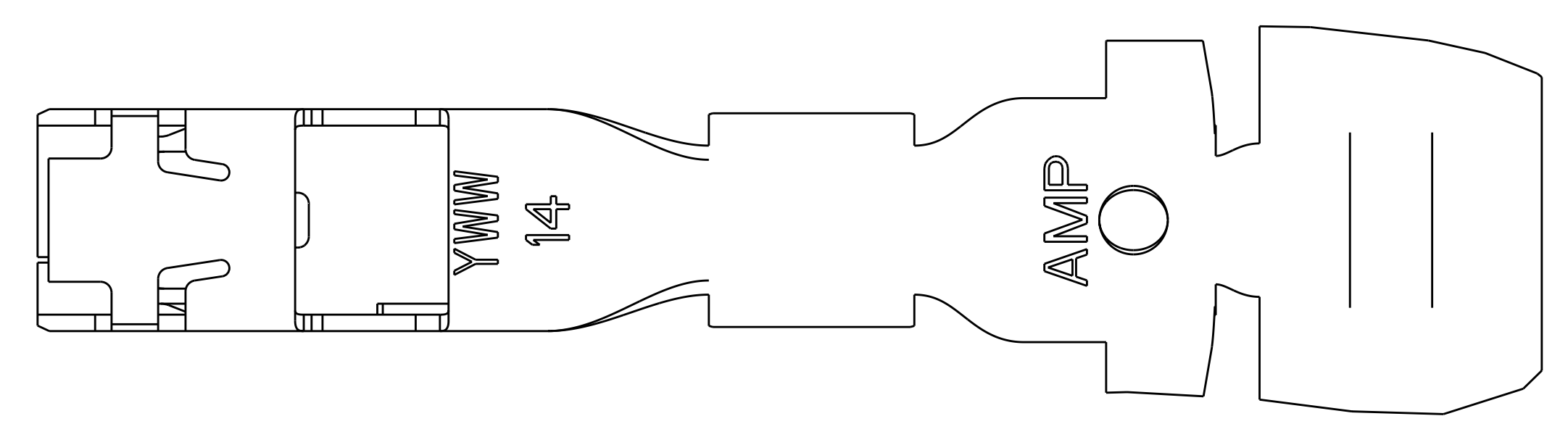
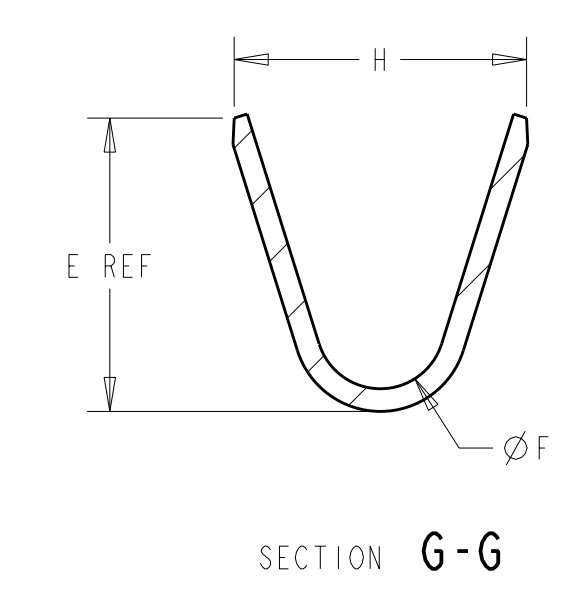
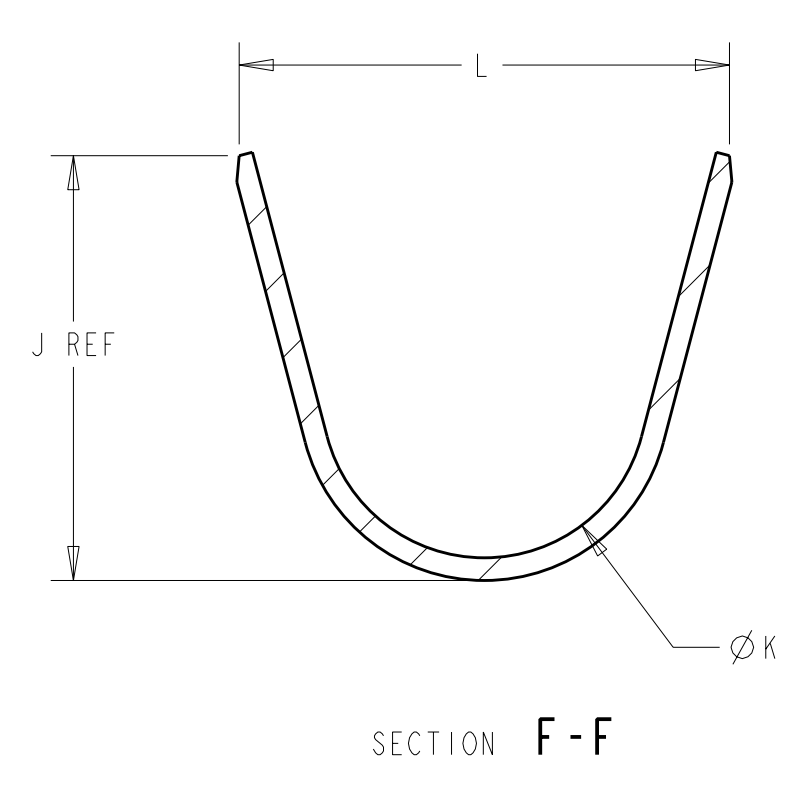
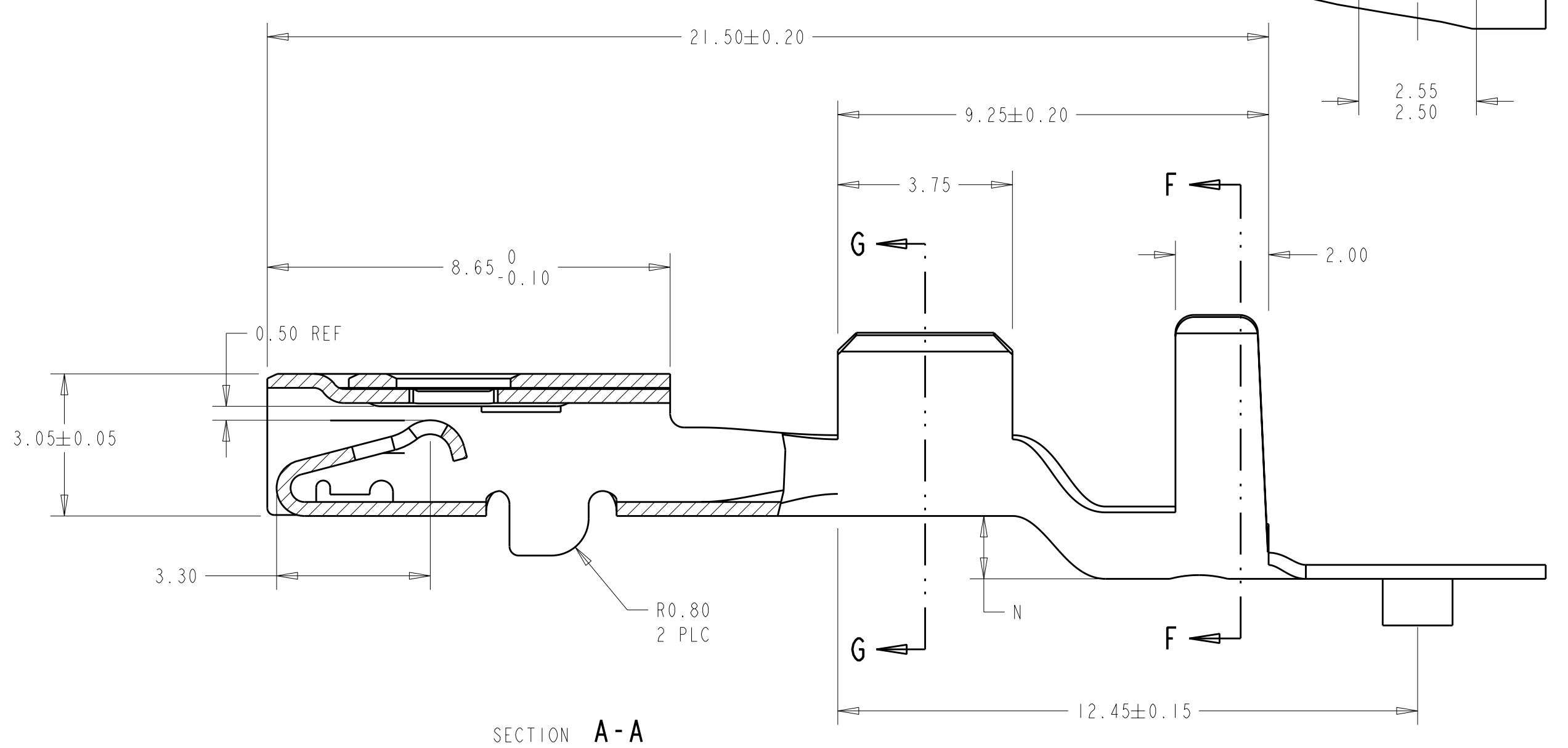
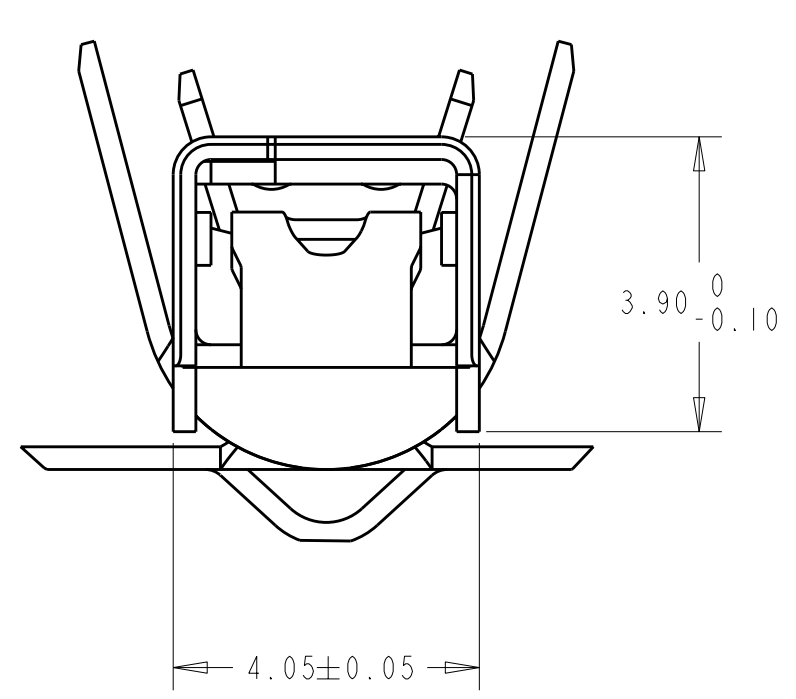

REELING	N	L	ØK	J	H	ØF	E	WIRE SIZE	PART NO.
△								12 AWG	I-1326032-2
								14 AWG	I-1326032-1
								16 AWG	I-1326032-0
△								18 AWG	1326032-9
								20 AWG	1326032-8
								22 AWG	1326032-7
	1.35	6.8	4.30	6.09	4.7	2.70	5.25	12 AWG	1326032-6
	1.35	6.5	4.30	5.62	3.9	1.70	3.88	14 AWG	1326032-5
	1.10	5.6	3.80	4.54	3.9	1.70	3.88	16 AWG	1326032-4
	1.10	5.6	3.80	4.54	3.3	1.30	2.76	18 AWG	1326032-3
	0.90	5.0	3.40	4.11	3.3	1.30	2.76	20 AWG	1326032-2
	0.90	5.0	3.40	4.11	2.5	0.90	2.11	22 AWG	1326032-1

THIS DRAWING IS A CONTROLLED DOCUMENT.

AWN: D. STRAUSSER 28APR99
 CHK: D. BROWN 28APR99
 APPV: D. BROWN 28APR99

TE Connectivity
2.8mm RECEPTACLE, SEALED

SAE/USCAR-2 8/97
 APPLICATION SPEC

114-13013
 WEIGHT: -

CUSTOMER DRAWING

SCALE: 10:1

SHEET 1 OF 1

REV E1