

Figure 1

## 1. INTRODUCTION

This instruction sheet covers the assembly procedure for J1939 CAN network system.

**IMPORTANT:** DO NOT use incorrect terminal combinations when assembling J1939 connections. To avoid network system problems, DO NOT use terminals other than specified. In addition, differing male blade thicknesses causes a low normal force and intermittent contact, which can result in failed communications between network components. The following assembly procedure must be used for this network system in data bus communications.

Reasons for reissue of this instruction sheet are provided in Section 5, REVISION SUMMARY.

## 2. DESCRIPTION

The network system consists of the following components (refer to Figure 1):

(Quantity) Description

- (8) .070 Series Receptacle Contact 173631-7 and Wire Seal 281934-2
- (1) AMP SUPERSEAL\* Automotive 4-Way Cap Housing 776308-1
- (1) AMP SUPERSEAL Automotive 2-Way Cap Housing 776309-1
- (1) 4-Way Connector Secondary Lock 776310-1
- (4) AMP SUPERSEAL 1.5 Series 2-Position Receptacle Connector 282080-1
- (1) 4-Way Connector with 120-Ohm Load Resistor Secondary Lock 776540-1
- (As Required) MINI-MIC Tab Contact 282109-3  
Note: Use this contact with AMP SUPERSEAL 1.5 Series 2-Position 282104-[ ] when mating to the J1939 CAN network system

## 3. ASSEMBLY PROCEDURE

Ensure that all contacts are crimped to the wires according the appropriate Application Specification: 114-5091 (for receptacle contacts) and 114-20045 (for tab contacts), then proceed with the following.

### 3.1. Intermediate Module Assembly

1. Insert the two contacts of the module plug into Circuits 1A and 2A of the cap housing and the two contacts of the continuing data link into Circuits 1B and 2B of the cap housing. Refer to Figure 2.
2. Insert the secondary lock into the front of the cap housing until it is fully seated.

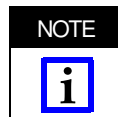

Ensure that the 4 blades of the secondary lock are mated to the 4 contacts at the back of the cap housing.

3. Repeat Steps 2 through 3 to assembly each intermediate module assembly.

### Assembling Intermediate Module Assembly

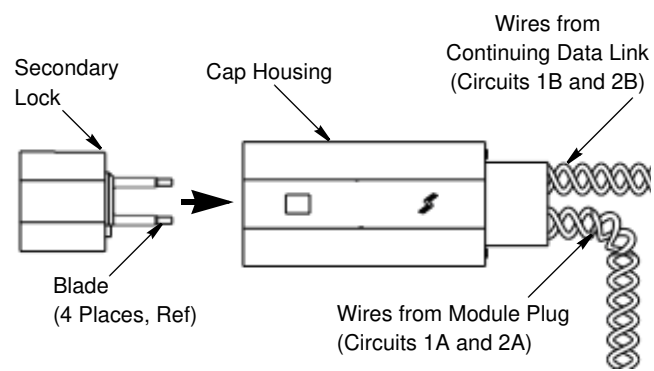

Figure 2

### 3.2. Final Module Assembly

1. Insert the two contacts of the module plug into Circuits 1A and 2A of the 2-position receptacle connector. Refer to Figure 3.

2. Insert the secondary lock with load resistor into the front of the 2-position receptacle connector until it is fully seated.



**NOTE** Ensure that the 2 blades of the secondary lock are mated to the 2 contacts at the back of the 2-position receptacle connector.

*Assembling Final Module Assembly*

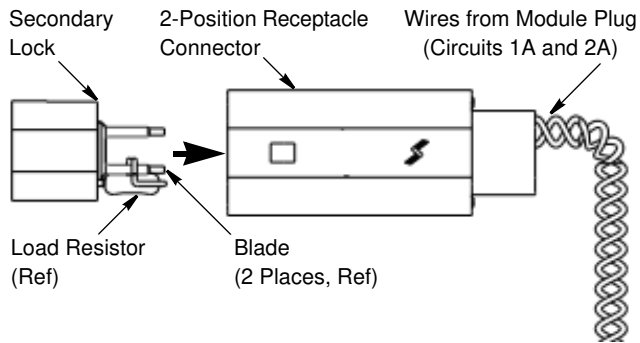

Figure 3

3.3. Data Input

1. Mate the data input cable with the front of the 2-position receptacle connector. See Figure 4, Detail A.
2. Mate the 2-position receptacle connector with the cap housing. Ensure that the locking lance “clicks” into place. See Figure 4, Detail B.

*Assembling Data Input*

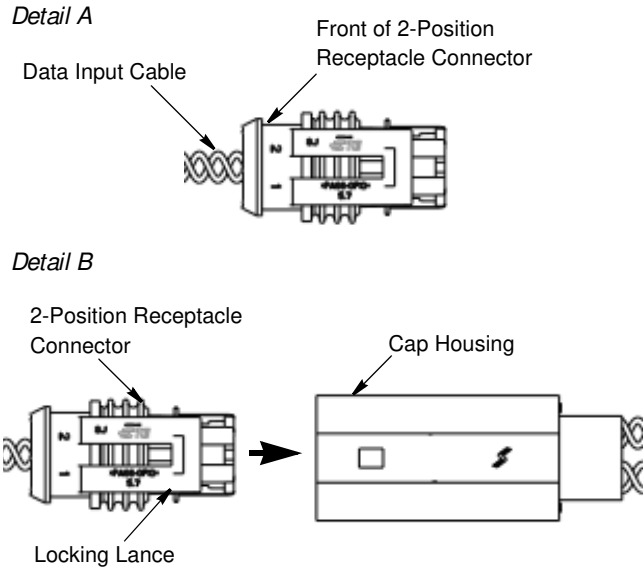

Figure 4

4. REPLACEMENT AND REPAIR

Components for this network system are not repairable. DO NOT use defective or damaged product.

5. REVISION SUMMARY

Revisions to this instruction sheet include:

- Added tab assembly and contact to Section 2
- Added reference to application specification to Section 3