

DESCRIPTION: **HIGH DENSITY MALE SOLDER CUP**

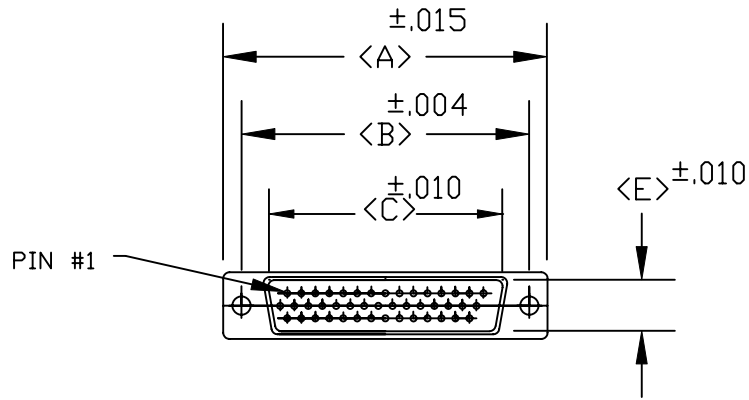

4 ROW

POS.	A	B	C	D	E	F	G
15	1.213	0.984	0.666	0.756	0.329	0.090	0.496
	30.80	24.99	16.92	19.20	8.36	2.29	12.60
26	1.543	1.312	0.994	1.091	0.329	0.090	0.496
	39.19	33.32	25.25	27.70	8.36	2.29	12.60
44	2.087	1.852	1.534	1.618	0.329	0.090	0.496
	53.00	47.04	38.96	41.10	8.36	2.29	12.60
62	2.732	2.500	2.181	2.256	0.329	0.095	0.496
	69.30	63.50	55.42	57.30	8.36	2.41	12.60
78	2.638	2.406	2.079	2.169	0.445	0.095	0.606
	67.00	61.00	52.80	55.10	11.30	2.41	15.39

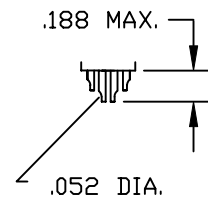
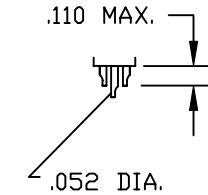
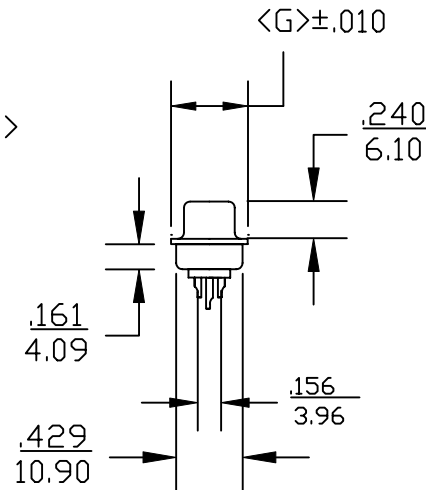
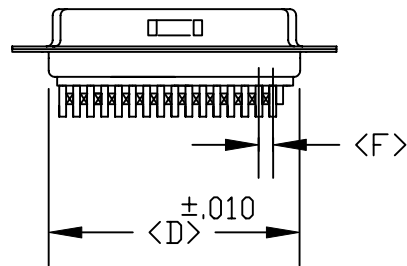

180-XXX-103LXX1

- SERIES _____
- POSITIONS _____
- 015
026
044
062
078
- GENDER _____
- 1 = MALE
2 = FEMALE
- TERMINATION _____
- 0 = SOLDER CUP
- SHELL PLATING _____
- 3 = NICKEL
- HARDWARE OPTIONS _____
- 00 = NO HARDWARE (.120Ø HOLE)
01 = 4-40 CLINCH-NUT .098" BOARD SIDE
02 = 4-40 CLINCH NUT .250" BOARD SIDE
03 = 4-40 CLINCH NUT .250" MATING SIDE
91 = 4-40 SPACER/BOARD LOCK .225"
- PLATING OPTIONS _____
- 1 = GOLD FLASH
2 = 30 MICRO-INCH GOLD

ELECTRICALS:

CURRENT RATING: 2 AMPS
CONTACT RESISTANCE: 15 mOHMS MAX.
INSULATOR RESISTANCE: 1000MOHMS MIN.
VOLTAGE: 500V FOR 1 MINUTE
TEMPERATURE: -50° TO +100°

MATERIALS:

SHELL: STEEL, NICKEL PLATED
INSULATOR: PBT - BLACK (UL-94-VO)
RoHS COMPLIANT

NOTE: WILL ACCEPT UPTO 24 AWG WIRE

	THESE DRAWINGS AND SPECIFICATIONS ARE THE PROPERTY OF NorComp AND SHALL NOT BE REPRODUCED, COPIED OR USED AS THE BASIS FOR THE MANUFACTURE OR SALE OF APPARATUS WITHOUT WRITTEN PERMISSION.		DRAWN: PAM JENKINS	DATE: 7-19-05
			CHECKED:	DATE:
NorComp			SCALE:	SHEET OF
			DWG NO.	
			180-XXX-103LXX1	

DESCRIPTION: CLINCH NUT HARDWARE

ALL CLINCH-NUTS ARE 4-40 INTERNAL THREADS

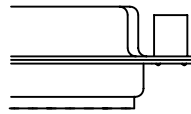

03X..... .250" (MATING SIDE) - CN8

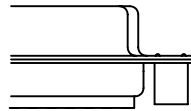

02X250" (BOARD SIDE) - CN2

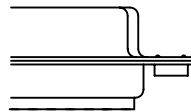

01X098" (BOARD SIDE) - CN1

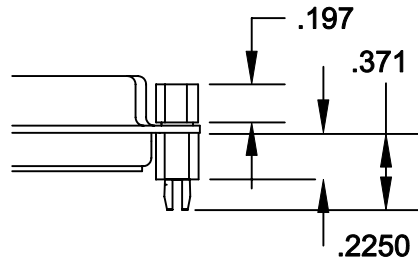

91X225" (BOARD SIDE) - .197 MATING SIDE - CN10/SFS0440

NOTE: 4-40 FEMALE SCREW LOCK IS REMOVABLE



THESE DRAWINGS AND SPECIFICATIONS ARE THE PROPERTY OF NorComp AND SHALL NOT BE REPRODUCED, COPIED OR USED AS THE BASIS FOR THE MANUFACTURE OF SALE OF APPARATUS WITHOUT WRITTEN PERMISSION.

DRAWN:
WAYNE ROBBINS

DATE:
8-23-98

CHECKED:
PAM JENKINS

DATE:
8-24-98

NorComp

SCALE:	SHEET	OF	REV
	1	1	1

DWG NO. CLINCH-NUT OPTIONS