

ANT™ + *Bluetooth*® low energy Module

Bluetooth® 4.2 low energy

EYAGJNZXX (32kB RAM)

Data Report

The **Bluetooth**® word mark and logos are owned by the **Bluetooth** SIG, Inc. and any use of such marks by TAIYO YUDEN CO., LTD. is under license.

ANT™ is a trademark of Dynastream Innovation Inc.

Document constituent list

Control name	Control No.	Document Page
General Items	HD-AG-A140402	1/5 - 5/5
Absolute maximum ratings	HD-AM-A140402	1/1
Electrical characteristics	HD-AE-A140402	1/8 - 8/8
Circuit schematic	HD-MC-A140402	1/3 - 3/3
Outline / Appearance	HD-AD-A140402	1/1
Pin Layout	HD-BA-A140402	1/2 - 2/2
Handling Precaution	HQ-BA-537	1/2 - 2/2
Packaging Specification	HD-BB-A140402	1/3 - 3/3
Antenna application note		1/3 - 3/3
Design guide		1/1
Notes		1/1
Precautions	HQ-BK-002	1/1

Revision History

14-Sep.-2015 > Ver.1.00 Release
 21-Dec.-2015 > Ver.1.01 Update
 18-Mar.-2016 > Ver.1.1 Update
 12-Jul.-2016 > Ver.1.2 Update
 09-Aug.-2016 > Ver.1.3 Update
 06-Feb.-2017 > Ver.1.4 Update
 19-Apr.-2017 > Ver.1.5 Update
 30-Jun.-2017 > Ver.1.6 Update
 25-Sep.-2017 > Ver.1.7 Update
 15-Dec.-2017 > Ver.1.8 Update
 30-May -2018 > Ver.1.9 Update

EYAGJNZXX

TAIYO YUDEN CO., LTD.

Control No. HD-AG-A140402	(1/5)	Control name General Items
------------------------------	-------	-------------------------------

Scope

This specification ("Specification") applies to the hybrid IC "EYAGJNZXX", a ANT™+ **Bluetooth**® 4.2
 ※ low energy module ("Product") manufactured by TAIYO YUDEN Co., Ltd. ("TAIYO YUDEN")

1. Type: EYAGJN

User Code: EYAGJNZXX (32kB RAM)

*User Code may be changed for mass production or other cases.

2. Function:

Radio frequency module. ANT™+**Bluetooth**® standard Ver 4.2※ low energy conformity

3. Application: Health & Fitness Equipment, Sensor, Toys**4. Structure:**

Hybrid IC loaded with silicon monolithic semiconductor

Compatible with industrial standard reflow profile for Pb-free solders

Can meet with RoHS compliance (Pb, Cd, Hg, Cr⁶⁺, PBB, PBDE)

5. Outline: 11.3 x 5.1 x 1.3 mm

28-pin Land Grid Array

6. Marking: Part number, Lot number**7. Features:**

- Small outline by PCB substrate
- Low power consumption
- Integrated antenna
- Integrated system clock
- ANT™+**Bluetooth**® 4.2※ low energy conformity
- Slave Role

8. Packaging:

Packaging method: Tape & reel + aluminum moisture barrier bag

Packaging unit: 2000

*It might be provided as tray at sample stage.

※Supported by S130 SoftDevice

TAIYO YUDEN CO., LTD.

Control No. HD-AG-A140402	(2/5)	Control name General Items
------------------------------	-------	-------------------------------

9. Note:

- a. Any question arising from this Specification shall be solved through mutual discussion by the parties hereof.
- b. This Product is not designed to be radiation durable and should not be used under the circumstance of radiation.
- c. The operating conditions of this Product are as shown in this Specification. Please note that TAIYO YUDEN shall not be liable for a failure and/or abnormality which is caused by use under the conditions other than the operating conditions hereof.
- d. The Product mentioned in this Specification is manufactured for use in Health & Fitness Equipment, Sensor and Toys. Before using this Product in any special equipment (such as medical equipment, space equipment, air craft, disaster prevention equipment), where higher safety and reliability are duly required, the applicability and suitability of this Product must be fully evaluated by the customer at its sole risk to ensure correct and safe operation of these special equipments. Also, evaluation of the safety function of this Product even for use in general electronics equipment shall be thoroughly made and when necessary, a protective circuit shall be added during the design stage, all at the customer's sole risk.
- e. a) You are requested to fully check and confirm by the start of mass production of this Product that (1) no bug, defect or other failure is included in firmware incorporated in this Product ("Incorporated Software"), (2) no bug defect or other failure arising from installation of this Product in which is contained Incorporated Software into your products is included in Incorporated Software, and that Incorporated Software fully meets your intended use, although TAIYO YUDEN sufficiently inspects or verifies quality of Incorporated Software.
b) Please note that TAIYO YUDEN is not responsible for any failure arising out of bugs or defects in Incorporated Software.
- f. TAIYO YUDEN warrants only that this Product is in conformity with this Specification for one year after purchase and shall in no event give any other warranty.
- g. Communication between this Product and others might not be established nor maintained depending on radio environment or operating conditions of this Product and other ANT™ or Bluetooth® products.
- h. In order to test for Radio Law certification with a device incorporating this module, the Host Software must be able to put the module into test mode. Please contact TAIYO YUDEN for further details.
- i. This Product operates in the unlicensed ISM band at 2.4GHz. In case this Product is used around the other wireless devices which operate in same frequency band of this Product, there is a possibility that interference may occur between this Product and such other devices. If such interference occurs, please stop the operation of other devices or relocate this Product before using this Product or do not use this Product around the other wireless devices.
- j. Please thoroughly evaluate our module with your products before going mass production.
- k. User Code Modification Notice.
User Code for sample modules or part numbers in this Specification are TAIYO YUDEN standard part numbers. When any modification is made to a module to meet requested specifications, the part number will be changed. Please contact TAIYO YUDEN to confirm whether your part number needs to be modified.

Please see the following examples for cases when part numbers are modified:

- for specific firmware version (our standard item firmware will be upgraded occasionally)
- for other relevant cases (specific or different setting, form, sizes, or display etc..)

Control No. HD-AG-A140402	(3/5)	Control name General Items
------------------------------	-------	-------------------------------

l. Alternative components may used to this module. The intended components is used within the warranty written in this document (characteristics, size, operating condition, reliability, public regulation such as radio type approval) and Taiyo Yuden confirmed there are not any problems with the replacement. The traceability of the components is secured each production lot.

m. Caution for Export Control

This Product may be subject to governmental approvals, consents, licenses, authorizations, declarations, filings, and registrations for export or re-export of the Product, required by Japanese Foreign Exchange and Foreign Trade Law (including related laws and regulations) and/or any other country's applicable laws or regulations related to export control.

If you plan to export or re-export this Product, it is strongly recommended that you check and confirm, the necessary procedures to export or re-export of this Product as required by applicable laws and regulations, and if necessary, you have to obtain necessary and appropriate approvals or licenses from governmental authority at your own risk and expense.

n. Japan Regulatory Information

This module is approved with the specific antenna on this module.

a) Please ensure that your product can bear a label with the following information. If the product is so small that it is not practicable to place the label, please place it in the instruction manual and package. The mark diameter shall be equal or grater than 3mm.

This product installs a radio system which has been approved as a radio station in a low power data communication system based on the Radio Law.

EYAGJN : 001-A06159



R 001-A06159

o. Canada Regulatory Information

a) This device complies with Industry Canada license-exempt RSS standards. Operation is subject to the following two conditions: (1) this device may not cause interference, and (2) this device must accept any interference, including interference that may cause undesired operation of the device.

L'utilisation de ce dispositif est autorisée seulement aux conditions suivantes: (1) il ne doit pas produire de brouillage et (2) l'utilisateur du dispositif doit être prêt à accepter tout brouillage radioélectrique reçu, même si ce brouillage est susceptible de compromettre le fonctionnement du dispositif.

b) This product is certified as type of the portable device with Industry Canada Rules. To maintain compliance with RF Exposure requirement, please use within specification of this product.

Ce produit est certifié comme type de l'appareil portable avec Industrie Règles de Canada. Pour maintenir l'acquiescement avec exigence Exposition de RF, veuillez utiliser dans spécification de ce produit.

- IC: 4389B-EYAGJN

-FVIN : F1

c) Please notify certified ID by either one of the following method on your product.

Spécifiez ID certifiée dans votre produit par une de méthode suivante.

-Contains Transmitter module IC : 4389B-EYAGJN

-Contains IC : 4389B-EYAGJN

EYAGJNZXX

TAIYO YUDEN CO., LTD.

Control No. HD-AG-A140402	(4/5)	Control name General Items
------------------------------	-------	-------------------------------

- p. FCC Regulatory Information
- a) This device complies with part 15 of the FCC Rules. Operation is subject to the following two conditions: (1) This device may not cause harmful interference, and (2) this device must accept any interference received, including interference that may cause undesired operation.
 - b) Please notify certified ID by either one of the following method on your product.
 - Contains Transmitter Module FCC ID: RYYEYAGJN
 - Contains FCC ID: RYYEYAGJN
 - c) CAUTION: changes or modifications not expressly approved by the party responsible for compliance could void the use's authority to operate the equipment.
 - d) This product is certified as type of the portable device with FCC Rules. To maintain compliance with RF Exposure requirement, please use within specification of this product.
 - e) The antenna used for this transmitter must not be co-located or operating in conjunction with any other antenna or transmitter.
- q. CE Regulatory Information
- a) When your end product installs this module, it is required to proceed additional certification processes before placing on the market in EU member states to make your products fully comply with relative EU standards.
 - b) TAIYO YUDEN can provide you the test reports of conducted measurement portion for the radio module. You can utilize the test reports for the certification processes of your end product as it requires radio testing.
- r. This Product is designed for use in products which comply with *Bluetooth*[®] Specifications. TAIYO YUDEN disclaims and is not responsible for any liability concerning infringement by this Product under any intellectual property right owned by third party in case the customer uses this Product in any product which does not comply with Bluetooth Specifications (the "non-complying products"). Furthermore, TAIYO YUDEN warrants only that this Product complies with this Specification and does not grant any other warranty including warranty for application of the non-complying products.
- s. Taiyo Yuden writes firmware for fixed SoftDevice (EYAGJNZXX : S310 V3.0.0) to this product. Customer writes firmware that is match the customer applications including SoftDevice at the customer's own responsibility.
- t. The Electrical Characteristics defined in this Specification are of the module with above SoftDevice. If other firmware is installed, the characteristics may differ from the defined value in the Electrical Characteristics. Bluetooth qualification and radio type approval may become invalid.
- u. EYAGJN series module is qualified as PHY only with Component category by Bluetooth SIG. The QDID of this module is 69825. The final product needs to get qualification as End product combining with PHY (module), SoftDevice and Profile before selling the product. The combination of Link and Host layer is differ with SoftDevice. Please refer to following combination and consult with your qualification body and BQC.

EYAGJNZXX

TAIYO YUDEN CO., LTD.

Control No. HD-AG-A140402	(5/5)	Control name General Items
------------------------------	-------	-------------------------------

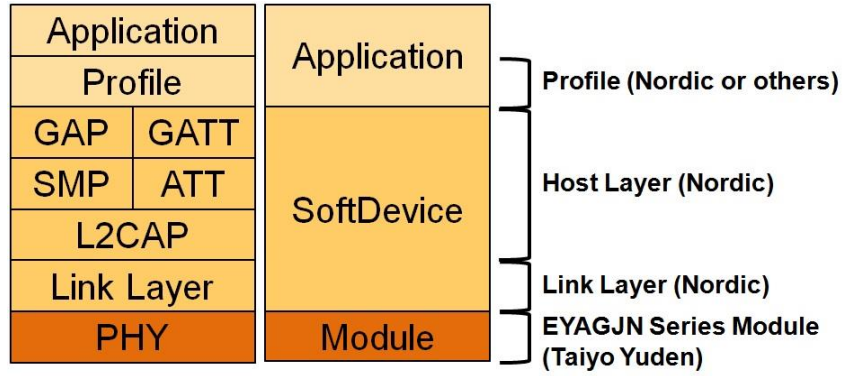

EYAGJNZXX

TAIYO YUDEN CO., LTD.

Control No. HD-AM-A140402	(1/1)	Control name Absolute maximum ratings
------------------------------	-------	--

Absolute maximum ratings

Symbol	Parameter	Min.	Max.	Units
VCC_NRF		-0.3	+3.6	V
GND			0	V
VIO		-0.3	VCC_NRF+ 0.3	V
Storage temperature		-40	+85	Deg-C
MSL	Moisture Sensitivity Level	3		
ESD HBM	Human Body Model		1	kV
ESD MM	Machine Model		100	V
Endurance	Flash Memory Endurance	20000		write/erase cycles
Retention	Flash Memory Retention	10 years		At 40 deg-C
Number of times an address can be written between erase cycles			2	times

EYAGJNZXX

TAIYO YUDEN CO., LTD.

Control No. HD-AE-A140402	(1/8)	Control name Electrical characteristics
------------------------------	-------	--

Electrical characteristics**Recommendation operating range**

Symbol	Parameter	Min.	Typ.	Max.	Units
VCC_NRF	Supply voltage, normal mode	1.8	3.0	3.6	V
VCC_NRF	Supply voltage, normal mode, DC/DC converter output voltage 1.9 V	2.1	3.0	3.6	V
tR_VCC_NRF	Supply rise time (0V to 1.8V)*1			100	ms
TA	Operation temperature	-25	25	85	Deg-C

*1 The on-chip power-on reset circuitry may not function properly for rise times outside the specified interval. Also after power off, it must start up from below 0.3V. The on-chip power-on reset circuitry may not function properly.

DC Specifications

The Specification applies for Topr.= 25 degrees C, VCC_NRF = 3.0V

Symbol	Parameter (condition)	Min.	Typ.	Max.	Units
VIH	Input high voltage	0.7 VCC_NRF		VCC_NRF	V
VIL	Input low voltage	GND		0.3 VCC_NRF	V
VOH	Output high voltage (std. drive, 0.5 mA)	VCC_NRF-0.3		VCC_NRF	V
VOH	Output high voltage (high-drive, 5 mA)	VCC_NRF-0.3		VCC_NRF	V
VOL	Output low voltage (std. drive, 0.5 mA)	GND		0.3	V
VOL	Output low voltage (high-drive, 5 mA)	GND		0.3	V
RPU	Pull-up resistance	11	13	16	kohm
RPD	Pull-down resistance	11	13	16	kohm
ITX,+4dBm	TX only run current @ POUT =+4 dBm		16		mA
ITX,0dBm	TX only run current @ POUT = 0 dBm		10.5		mA
IRX	RX only run current		13		mA
IOFF	Current in SYSTEM-OFF, no RAM retention		0.6		uA
IOFF,8k	Current in SYSTEM-OFF mode 8 kB SRAM retention		0.6		uA
ION	SYSTEM-ON base current with 32 kB RAM enabled.		3.8		uA

Note that when you use the RC oscillator, it will increase around 10uA of average power consumption compared to a 32.768kHz crystal.

TAIYO YUDEN CO., LTD.

EYAGJNZXX

TAIYO YUDEN CO., LTD.

Control No. HD-AE-A140402	(2/8)	Control name Electrical characteristics
------------------------------	-------	--

UART specifications

Symbol	Description	Note	Min.	Typ.	Max.	Units
I_{UART1M}	Run current at max baud rate.			230		μA
I_{UART115k}	Run current at 115200 bps.			220		μA
I_{UART1k2}	Run current at 1200 bps.			210		μA
f_{UART}	Baud rate for UART.		1.2		1000	kbps

Control No.
HD-AE-A140402

(3/8)

Control name
Electrical characteristics

SPI Slave specifications

Symbol	Description	Min.	Typ.	Max.	Units
$I_{SPI125K}$	Run current for SPI slave at 125 kbps. ¹		180		μA
I_{SPI2M}	Run current for SPI slave at 2 Mbps. ¹		183		μA
f_{SPI}	Bit rates for SPIS.	0.125		2	Mbps

1. CSN asserted.

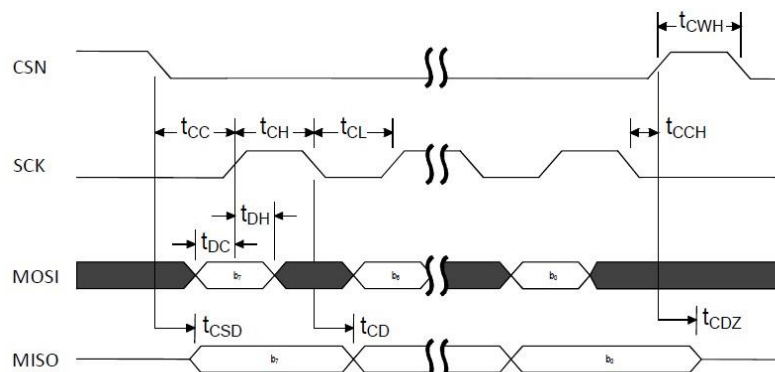

SPI timing diagram, one byte transmission, SPI Mode 0

Symbol	Description	Note	Min.	Typ.	Max.	Units
t_{DC}	Data to SCK setup.		10			ns
t_{DH}	SCK to Data hold.		10			ns
t_{CSD}	CSN to Data valid.	Low power mode. ¹ Constant latency mode. ¹			7100 2100	ns
t_{CD}	SCK to Data Valid.	$C_{LOAD} = 10 \text{ pF}$			97 ²	ns
t_{CL}	SCK Low time.		40			ns
t_{CH}	SCK High time.		40			ns
t_{CC}	CSN to SCK Setup.	Low power mode. ¹ Constant latency mode. ¹	7000 2000			ns
t_{CCH}	Last SCK edge to CSN Hold.		2000			ns
t_{CWH}	CSN Inactive time.		300			ns
t_{CDZ}	CSN to Output High Z.				40	ns
f_{SCK}	SCK frequency.		0.125		2	MHz
t_R, t_F	SCK Rise and Fall time.				100	ns

1. For more information on how to control the sub power modes, see the *nRF51 Series Reference Manual*.

2. Increases/decreases with 1.2 ns/pF load.

Control No. HD-AE-A140402	(4/8)	Control name Electrical characteristics
------------------------------	-------	--

SPI Master specifications

Symbol	Description	Min.	Typ.	Max.	Units
$I_{SPI125K}$	Run current for SPI master at 125 kbps.		180		μA
I_{SPI4M}	Run current for SPI master at 4 Mbps.		200		μA
f_{SPI}	Bit rates for SPI.	0.125		4	Mbps

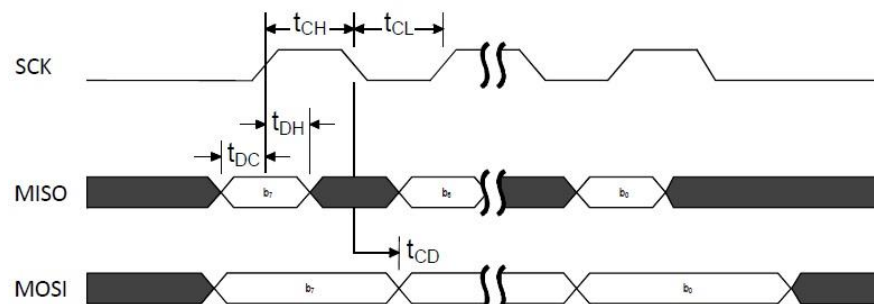

Symbol	Description	Note	Min.	Typ.	Max.	Units
t_{DC}	Data to SCK setup.		10			ns
t_{DH}	SCK to Data hold.		10			ns
t_{CD}	SCK to Data valid.	$C_{LOAD} = 10 \text{ pF}$			97 ¹	ns
t_{CL}	SCK Low time.		40			ns
t_{CH}	SCK High time.		40			ns
f_{SCK}	SCK Frequency.		0.125		4	MHz
t_R, t_F	SCK Rise and Fall time.				100	ns

1. Increases/decreases with 1.2 ns/pF load.

Control No. HD-AE-A140402	(5/8)	Control name Electrical characteristics
------------------------------	-------	--

TWI specifications

Symbol	Description	Note	Min.	Typ.	Max.	Units
I_{2W100K}	Run current for TWI at 100 kbps.			380		μA
I_{2W400K}	Run current for TWI at 400 kbps.			400		μA
f_{2W}	Bit rates for TWI.		100		400	kbps
$t_{TWI,START}$	Time from STARTRX/STARTTX task is given until start condition.	Low power mode. ¹ Constant latency mode. ¹		3 1	4.4	μs

1. For more information on how to control the sub power modes, see the *nRF51 Series Reference Manual*.

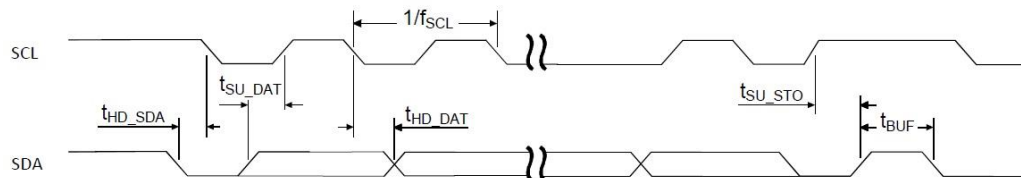

Symbol	Description	Standard		Fast		Units
		Min.	Max.	Min.	Max.	
f_{SCL}	SCL clock frequency.		100		400	kHz
t_{HD_STA}	Hold time for START and repeated START condition.	5200		1300		ns
t_{SU_DAT}	Data setup time before positive edge on SCL.	300		300		ns
t_{HD_DAT}	Data hold time after negative edge on SCL.	300		300		ns
t_{SU_STO}	Setup time from SCL goes high to STOP condition.	5200		1300		ns
t_{BUF}	Bus free time between STOP and START conditions.	4700		1300		ns

Control No. HD-AE-A140402	(6/8)	Control name Electrical characteristics
------------------------------	-------	--

GPIOTE specifications

Symbol	Description	Min.	Typ.	Max.	Units
$I_{\text{GPIOTE,IN}}$	Run current with 1 or more GPIOTE active channels in Input mode.		22		μA
$I_{\text{GPIOTE,OUT}}$	Run current with 1 or more GPIOTE active channels in Output mode.		0.1		μA
$I_{\text{GPIOTE,IDLE}}$	Run current when all channels in Idle mode. PORT event can be generated with a delay of up to t_{1V2} .		0.1		μA

Note: Setting up one or more GPIO DETECT signals to generate PORT EVENT, which can be used either as a wakeup source or to give an interrupt, will not lead to an increase of the current consumption.

EYAGJNZXX

TAIYO YUDEN CO., LTD.

Control No. HD-AE-A140402	(7/8)	Control name Electrical characteristics
------------------------------	-------	--

RF Specifications

Symbol	Description	Min.	Typ.	Max.	Units
Fop	Operating frequencies	2402		2480	MHz
PLLres	PLL programming resolution		1		MHz
Df	Frequency deviation	+/-225	+/-250	+/-275	kHz
PRF	Maximum output power		4		dBm
PRFC	RF power control range	20	24		dB
PRFCR	RF power accuracy			+/-4	dB
PWHISP	RF power whisper mode		-30		dBm
PBW	20 dB bandwidth for modulated carrier		950	1100	kHz
PRF1	1st Adjacent Channel Transmit Power 1 MHz			-20	dBc
PRF2	2nd Adjacent Channel Transmit Power 2 MHz			-45	dBc
PRXMAX	Maximum received signal strength at < 0.1% PER		0		dBm
PSENS IT	Receiver sensitivity (0.1% BER) Ideal transmitter		-93		dBm
PSENS DT	Receiver sensitivity (0.1% BER) dirty transmitter		-91		dBm

Control No. HD-AE-A140402	(8/8)	Control name Electrical characteristics
------------------------------	-------	--

DFU Specifications

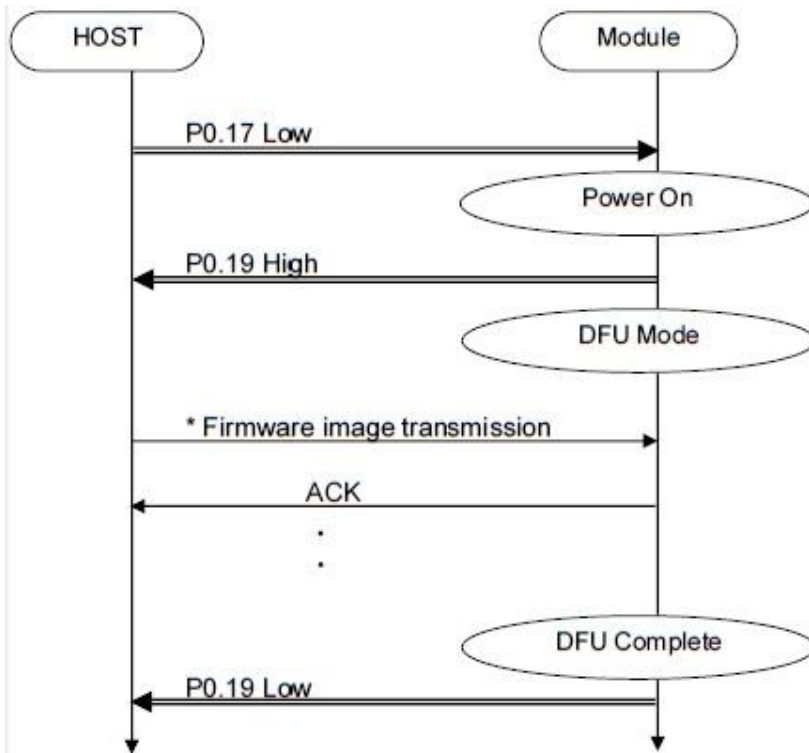

UART	
Baud rate : 38400 bps	UART PIN :
Data : 8 bit	RX : P0.03
Parity : none	TX : P0.01
Stop : 1 bit	CTS : P0.02
Hardware flow control : Enabled	RTS : P0.00

* see Nordic Infocenter and nRFgo Studio help

[Nordic Infocenter] <http://infocenter.nordicsemi.com/index.jsp>
 Software Development Kit > nRF51 SDK > nRF51 SDK v9.0.0 > Examples > BLE DFU Bootloader
 > Transport layers > Serial (HCI) packet format
 Software Development Kit > nRF51 SDK > nRF51 SDK v9.0.0 > Examples > BLE DFU Bootloader
 > Creating a DFU bootloader

[nRFgo Studio] Download from Nordic web site <http://www.nordicsemi.com>
 nRFgo Studio help > Program nRF51 devices > Serial Bootloader

Control No. HD-MC-A140402	(1/3)	Control name Circuit Schematic
------------------------------	-------	-----------------------------------

Block Diagram

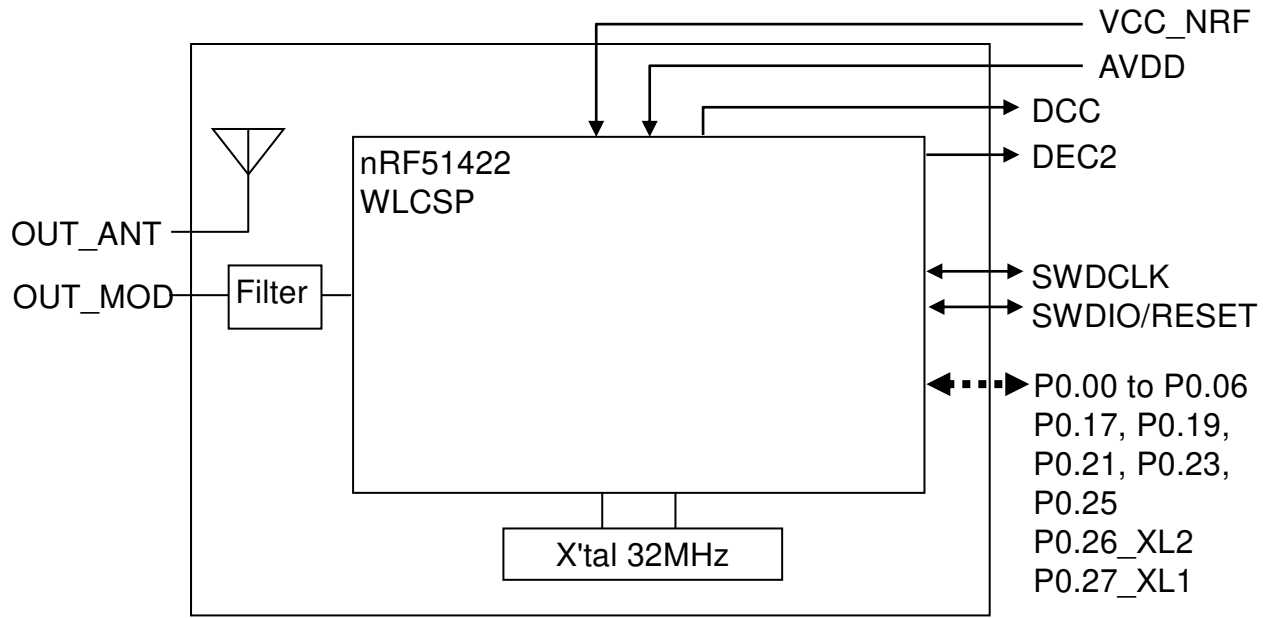

Control No. HD-MC-A140402	(2/3)	Control name Circuit Schematic
------------------------------	-------	-----------------------------------

Sample circuits

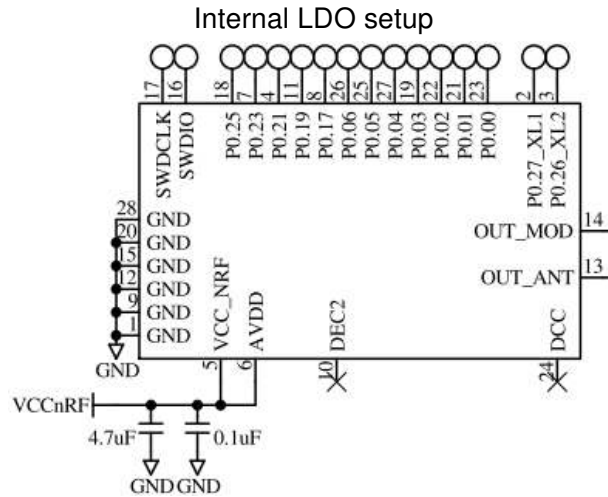

Internal LDO setup with external 32.768kHz X'tal

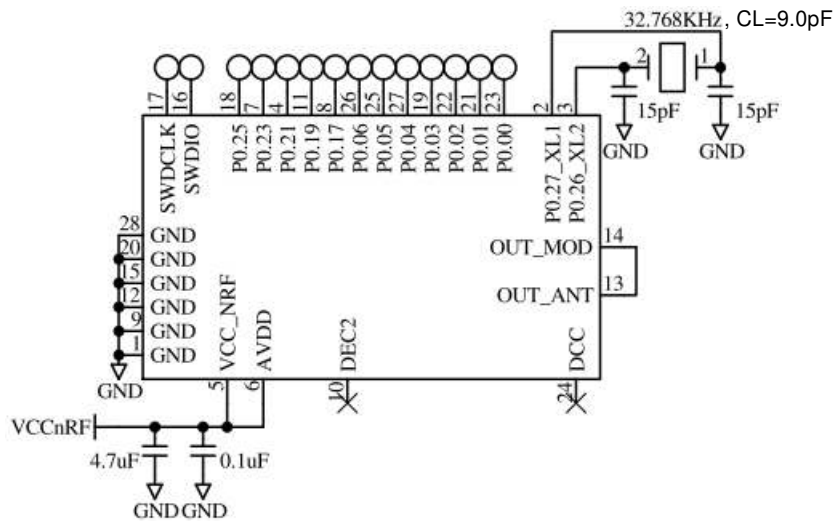

DC/DC converter setup

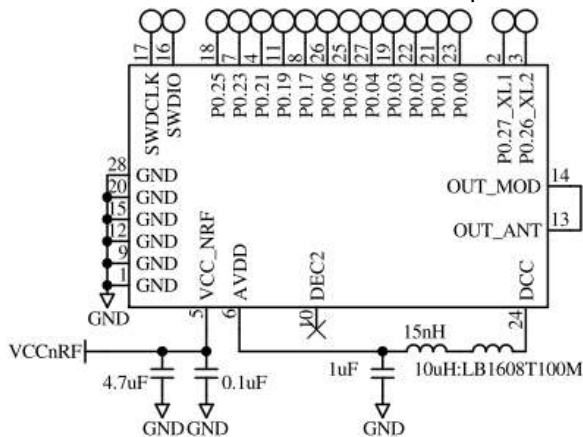

Low voltage mode setup

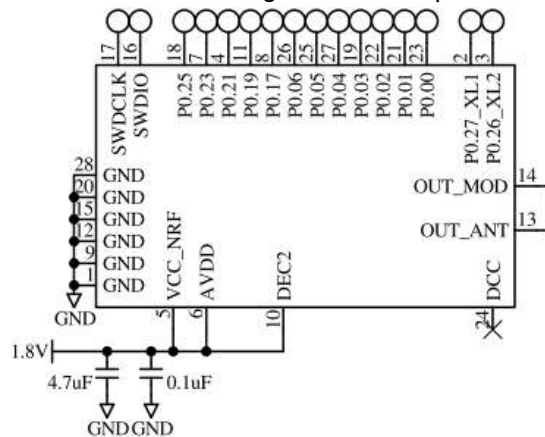

Control No. HD-MC-A140402	(3/3)	Control name Circuit Schematic
------------------------------	-------	-----------------------------------

Reference Circuits

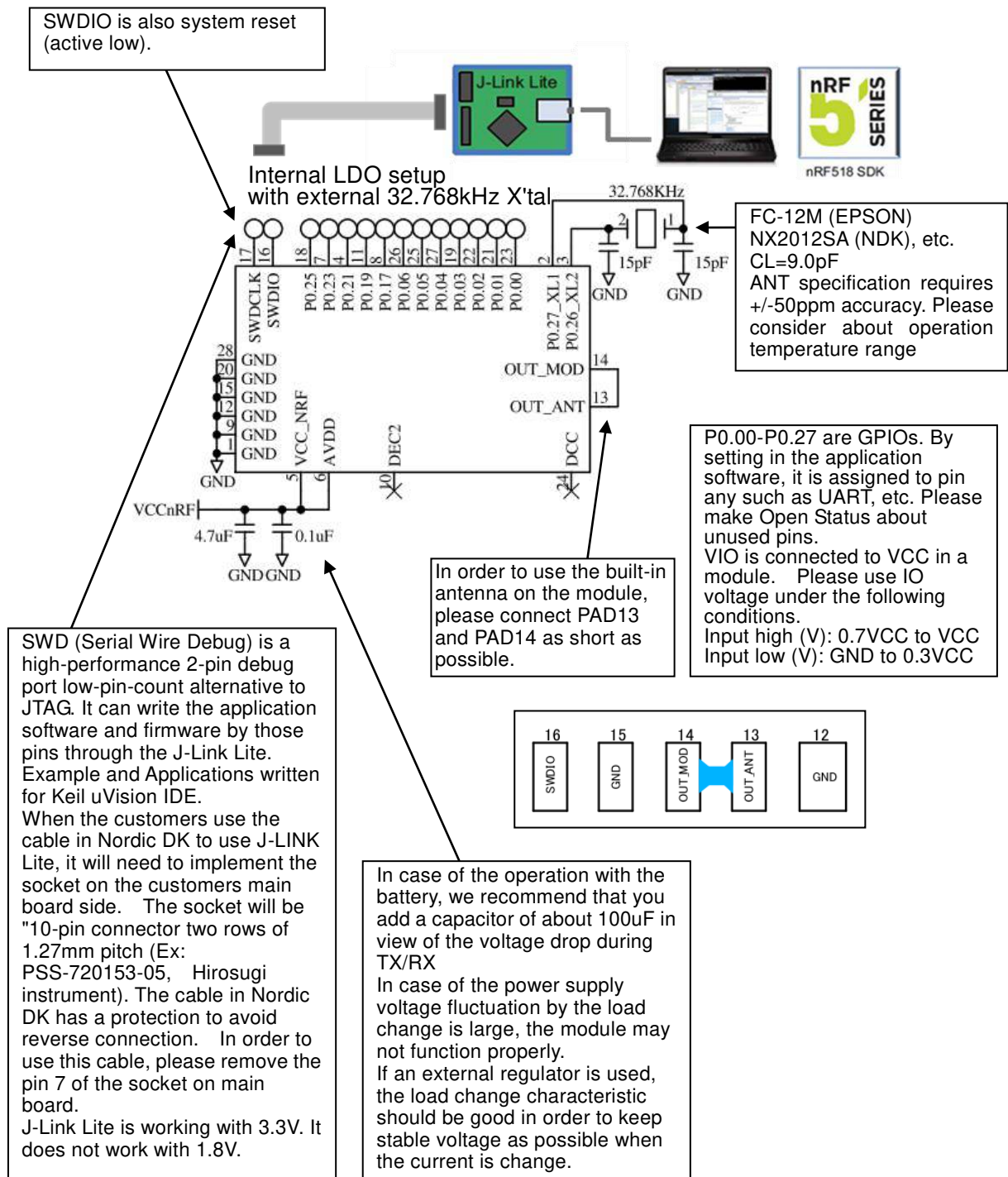

EYAGJNZXX

TAIYO YUDEN CO., LTD.

Control No. HD-AD-A140402	(1/1)	Control name Outline/Appearance
------------------------------	-------	------------------------------------

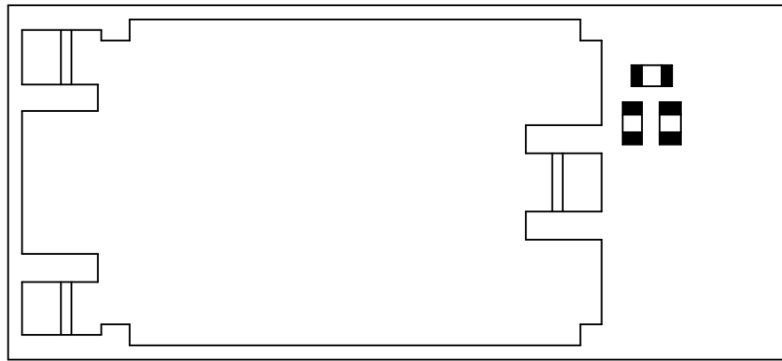

Tolerance: +/- 0.2mm

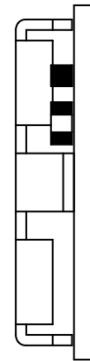

Tolerance: +/- 0.2mm
Unit : (mm)

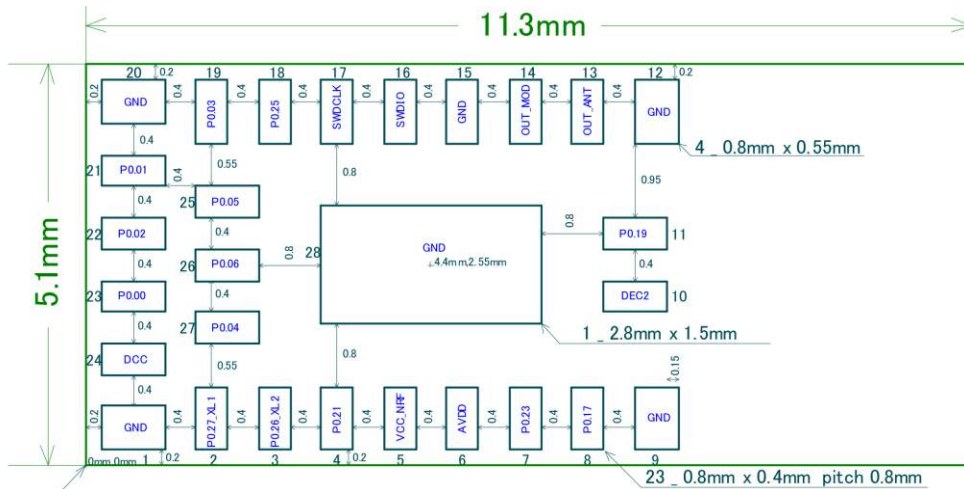

Top view

The dimension of the land pattern is the same as a foot pattern.

Recommended metal mask for solder printing

Pad size	Metal mask opening
Signal pad 23 - 0.4 x 0.8 mm	0.35 x 0.7 mm
Corner pad 4 - 0.55 x 0.8 mm	0.45 x 0.75 mm
Center pad 1 - 2.8 x 1.5 mm	1.1 x 1.2 mm x 2

The metal mask thickness: t=0.1mm

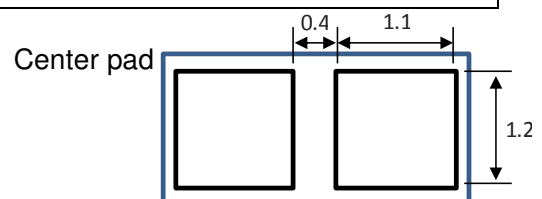

TAIYO YUDEN CO., LTD.

EYAGJNZXX

TAIYO YUDEN CO., LTD.

Control No. HD-BA-A140402	(1/2)	Control name Pin Layout
------------------------------	-------	----------------------------

Pin Descriptions

Pin	Pin name	Pin function	Description
1	GND	Ground	Ground (0 V)
2	P0.27 AIN1 XL1	Digital I/O Analog input Analog input	General purpose I/O pin ADC input 1 Crystal connection for 32.768kHz crystal oscillator or external 32.768kHz crystal reference
3	P0.26 AIN0 XL2	Digital I/O Analog input Analog output	General purpose I/O pin ADC input 0 Crystal connection for 32.768kHz crystal oscillator
4	P0.21	Digital I/O	General purpose I/O pin
5	VCC_NRF	Power	Power supply
6	AVDD	Power	Analog Power supply
7	P0.23	Digital I/O	General purpose I/O pin
8	P0.17	Digital I/O	General purpose I/O pin
9	GND	Ground	Ground (0 V)
10	DEC2	Power	Power supply for low voltage mode
11	P0.19	Digital I/O	General purpose I/O pin
12	GND	Ground	Ground (0 V)
13	OUT_ANT	Antenna In/Out	Internal antenna. It should be connected to Pin 14 OUT_MOD for normal operation.
14	OUT_MOD	RF In/Out	RF I/O pin. It should be connected to Pin 13 OUT_ANT for normal operation.
15	GND	Ground	Ground (0 V)
16	SWDIO	Digital I/O	System reset (active low). Also HW debug and flash programming I/O
17	SWDCLK	Digital input	HW debug and flash programming I/O
18	P0.25	Digital I/O	General purpose I/O pin
19	P0.03 AIN4	Digital I/O Analog input	General purpose I/O pin ADC input 4
20	GND	Ground	Ground (0 V)
21	P0.01 AIN2	Digital I/O Analog input	General purpose I/O pin ADC input 2
22	P0.02 AIN3	Digital I/O Analog input	General purpose I/O pin ADC input 3

TAIYO YUDEN CO., LTD.

EYAGJNZXX

TAIYO YUDEN CO., LTD.

Control No. HD-BA-A140402	(2/2)	Control name Pin Layout
------------------------------	-------	----------------------------

Pin	Pin name	Pin function	Description
23	P0.00 AREF0	Digital I/O Analog input	General purpose I/O pin ADC Reference voltage
24	DCC	Power	DC/DC output
25	P0.05 AIN6	Digital I/O Analog input	General purpose I/O pin ADC input 6
26	P0.06 AIN7 AREF1	Digital I/O Analog input Analog input	General purpose I/O pin ADC input 7 ADC Reference voltage
27	P0.04 AIN5	Digital I/O Analog input	General purpose I/O pin ADC input 5
28	GND	Ground	Ground (0 V)

EYAGJNZXX

TAIYO YUDEN CO., LTD.

Control No. HQ-BA-537	(1/2)	Control name Handling Precaution
--------------------------	-------	-------------------------------------

This specification describes desire and conditions especially for mounting.

Desire/Conditions

(1) Environment conditions for use and storage

1. Store the components in an environment of < **40deg-C/90%RH** if they are in a moisture barrier bag packed by TAIYO YUDEN.
2. Keep the factory ambient conditions at < **30deg-C/60%RH**.
3. Store the components in an environment of < **25±5deg-C/10%RH** after the bag is opened.
(The condition is also applied to a stay in the manufacture process).

(2) Conditions for handling of products

Make sure all of the moisture barrier bags have no holes, cracks or damages at receiving. If an abnormality is found on the bag, its moisture level must be checked in accordance with 2 in (2).

Refer to the label on the bag.

1. All of the surface mounting process (reflow process) must be completed **in 12 months** from the bag sea date.
2. Make sure humidity in the bag is less than **10%RH** immediately after open, using a humidity indicator card sealed with the components.
3. **All** of the surface mounting process (reflow process including rework process) must be completed in **168 hours** after the bag is opened (inclusive of any other processes).
4. If any conditions in (1) or condition 2 and 3 in (2) are not met, bake the components in accordance with the conditions at **125deg-C 24hours**
5. As a rule, baking the components in accordance with conditions 4 in (2) shall be once.
6. Since semi-conductors are inside of the components, they must be free from static electricity while handled.(<100V) Use ESD protective floor mats, wrist straps, ESD protective footwear, air ionizers etc. , if necessary.
7. Please make sure that there are lessen mechanical vibration and shock for this module, and do not drop it.
8. Please recognize pads of back side at surface mount.
9. Washing the module is not recommended. If washing cannot be avoided, please test module functionality and performance after thoroughly drying the module.
We cannot be held responsible for any failure due washing the module
10. Please perform temperature conditions of module at reflow within the limits of the following.
Please give the number of times of reflow as a maximum of 2 times.

TAIYO YUDEN CO., LTD.

EYAGJNZXX

TAIYO YUDEN CO., LTD.

Control No. HQ-BA-537	(2/2)	Control name Handling Precaution
--------------------------	-------	-------------------------------------

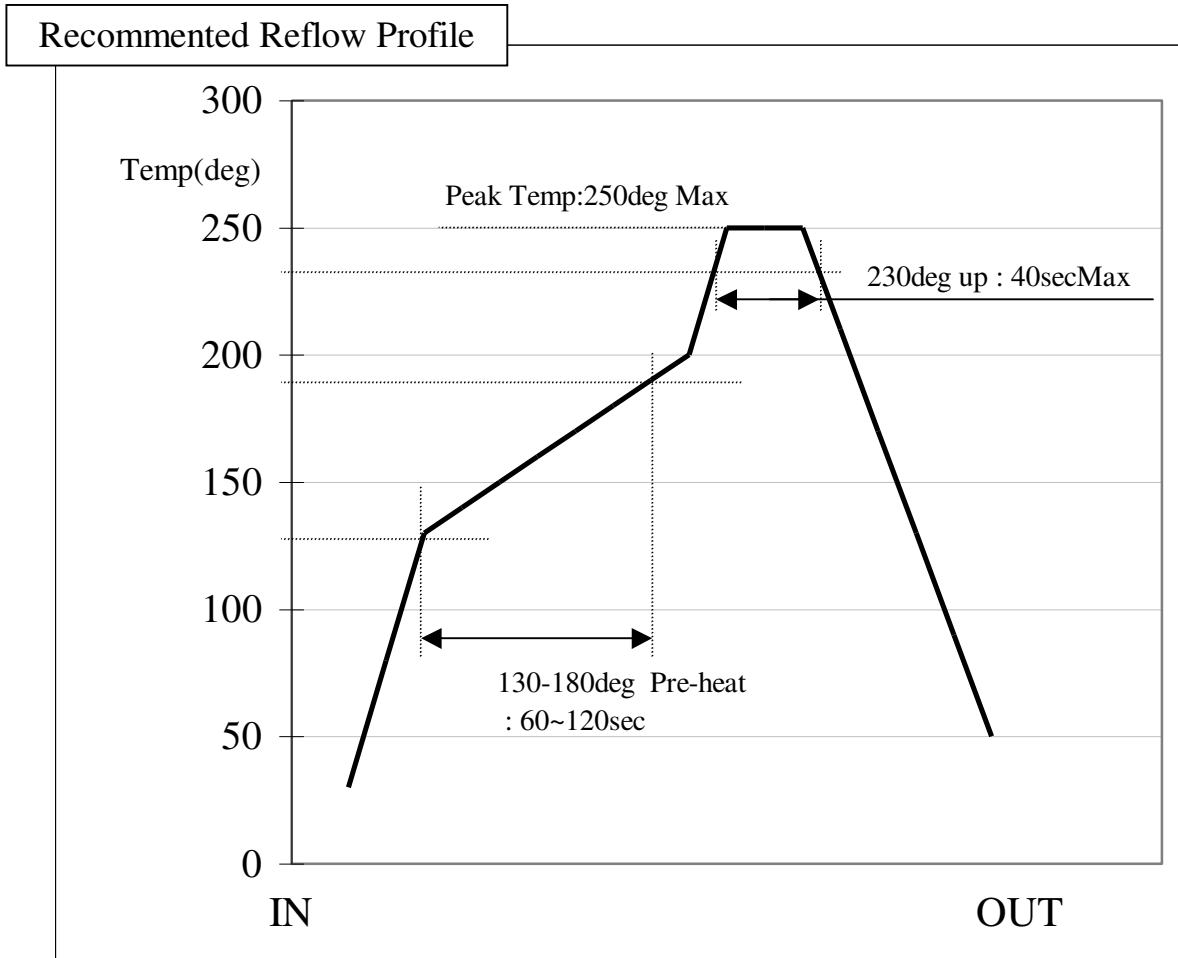

TAIYO YUDEN CO., LTD.

Control No. HD-BB-A140402	(1/3)	Control name Packaging Specification
------------------------------	-------	---

Packaging Specification

梱包仕様

(1) Packaging Material 梱包材料

Name 部材名	Outline 概要	Materials 材質	Note 備考
Emboss エンボス	24mm wide - 12mmPitch 24mm幅 - 12mmピッチ	Conductive PS 導電性 PS	
Cover Tape カバーテープ			
Reel リール	φ 330 mm	Conductive PS 導電性 PS	
Desiccant 乾燥剤	30g×1		
Humidity indicator card 湿度インジケータ			
Aluminum moisture barrier bag アルミ防湿袋	420×460(mm)	(AS)PET/AL/NY/PE(AS)	
Label ラベル			
Corrugated cardboard box(Inner) 個装箱	339×351×74(mm)		
Corrugated cardboard box(Outer) 外装箱	369×369×277(mm)		

(2) Packaging Unit

梱包数量

Max 2000 pieces/Reel

Max 6000 pieces/Box(Outer)

(3) Packaging Figure

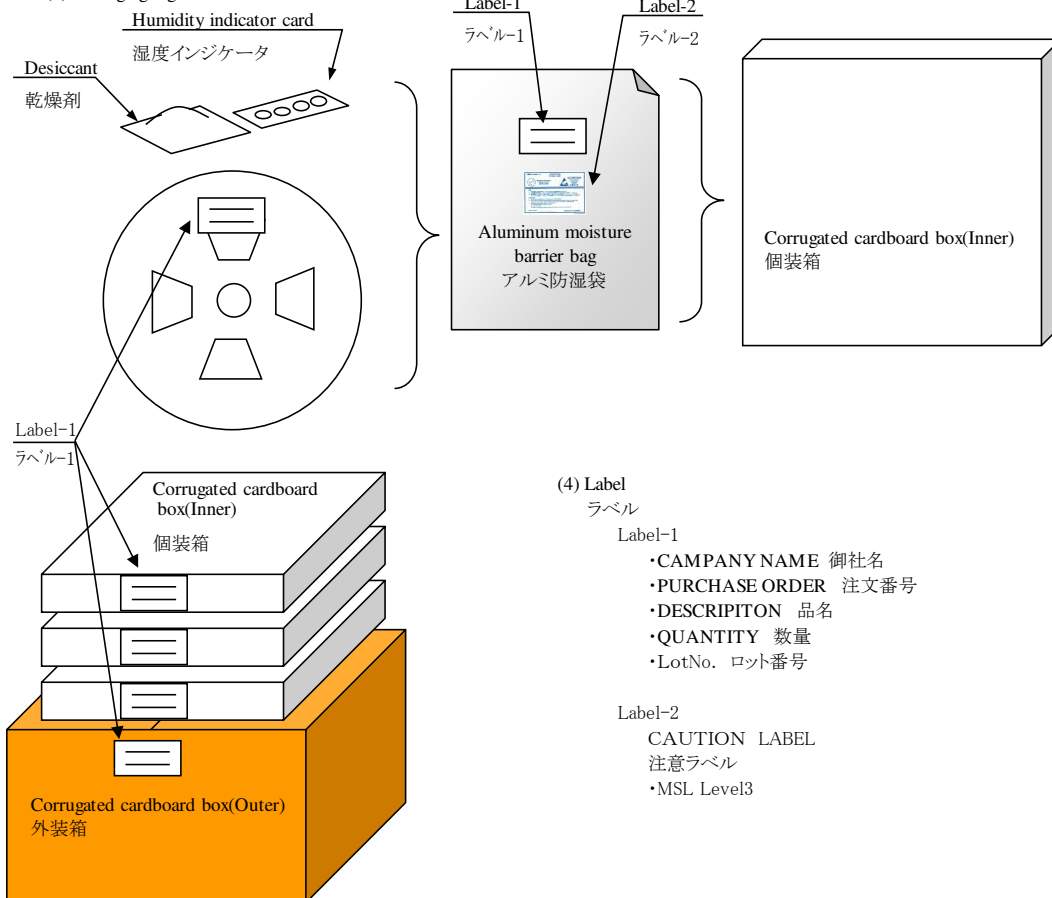

EYAGJNZXX

TAIYO YUDEN CO., LTD.

Control No. HD-BB-A140402 <small>Tape specification テーピング仕様</small>	(2/3)	Control name Packaging Specification
---	-------	---

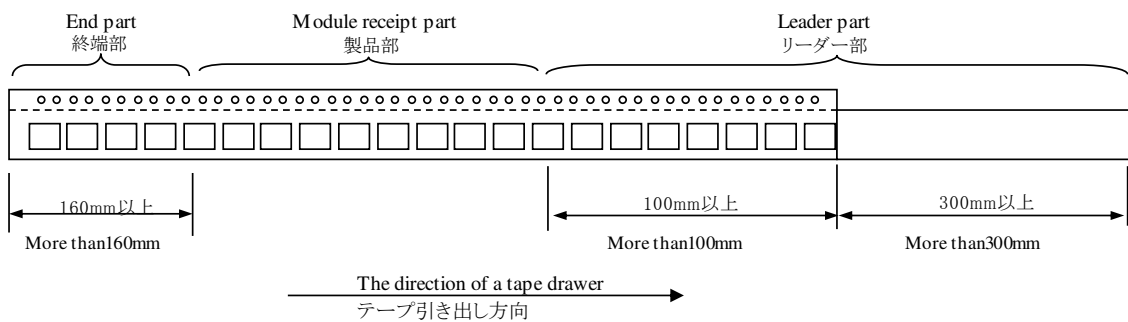
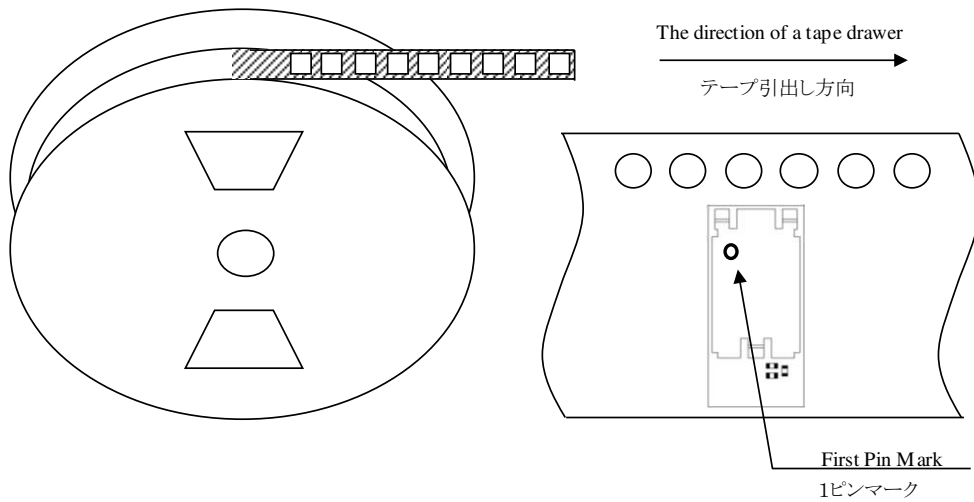

キャリアエンボス図面

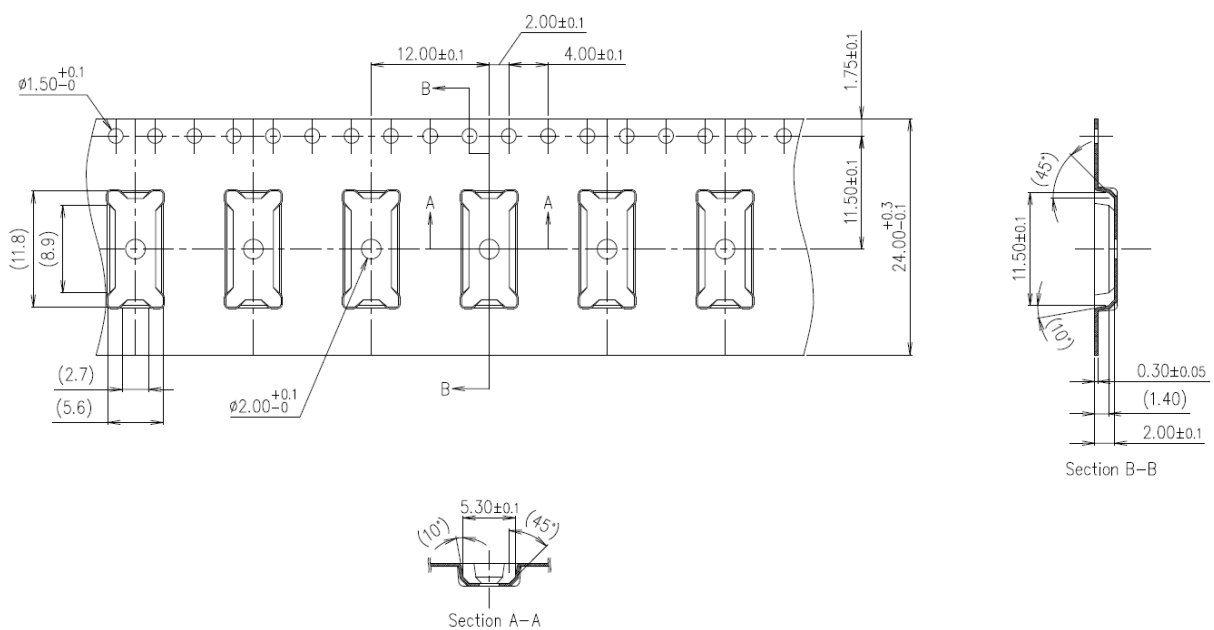

TAIYO YUDEN CO., LTD.

EYAGJNZXX

TAIYO YUDEN CO., LTD.

Control No.
HD-BB-A140402

(3/3)

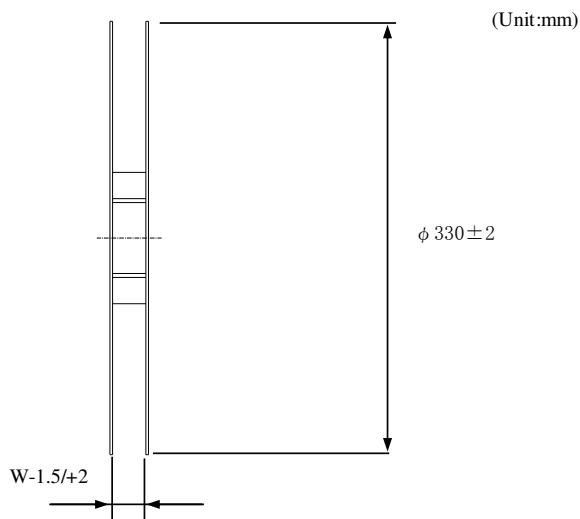
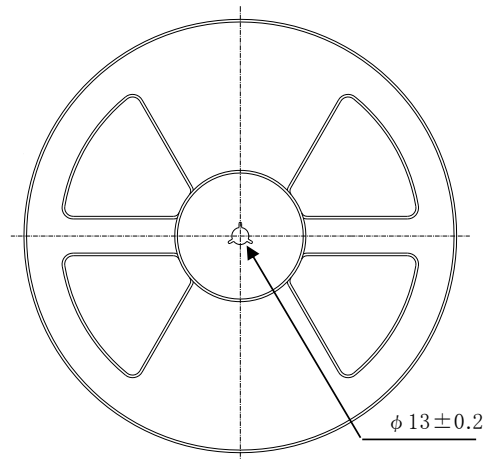
Control name
Packaging SpecificationReel specification
リール仕様

Tape wide	8mm	12mm	16mm	24mm	32mm	44mm
W	9.4mm	13.4mm	17.4mm	25.4mm	33.4mm	45.4mm

Taping performance
テーピング性能

Both of an embossing tape top cover tape bear this, when the power of 10N is applied in the direction of a drawer.
 ・エンボステープ、トップカバーテープともに、引き出し方向に10Nの力を加えた場合に、これに耐えること。

The exfoliation adhesion of a top cover tape is the intensity of 0.1~1.3N.
 (The angle to pull is 165~180 degrees. The speed to pull is 300 mm/min.)

・トップカバーテープの剥離強度は、角度165~180度に保ち、300mm/minのスピードでトップカバーテープを引っ張ったとき、0.1~1.3Nとする。

Note
備考

Lack of the parts in 1 reel is with two or less pieces.

1リール中の部品の欠落は2個までとします。(ラベル表示数量と梱包数は同じです。欠落とはテープ内でのモジュール抜けが2個まで許容させていただくという意味になります。)

MSL Level 3 Under control

MSL はレベル3 で管理しています。

TAIYO YUDEN CO., LTD.

Control No. (1/3)	Control name Antenna application note
----------------------	--

Recommended module mounting example

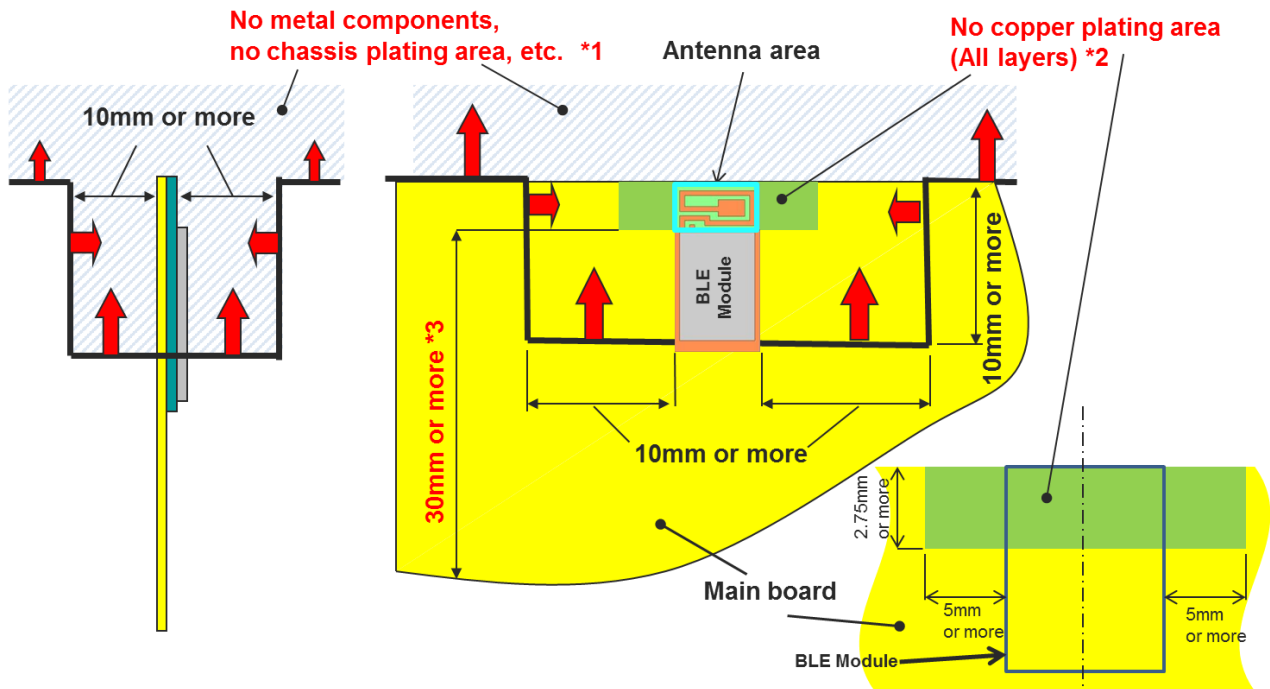

*1 Please do not place any metal components in blue shaded space,(*1) such as signal line and metal chassis as possible except for main board while mounting the components in *1 space on the main board is allowed except for no copper plating area. (*2).

*2 This area is routing prohibited area on the main board. Please do not place copper on any layer. Please remain use of FR-4 dielectric material. The antenna is tuned with the FR-4.

*3 Characteristics may deteriorate when GND pattern length is less than 30mm. It should be 30 mm or more as possible.

Even when above mentioned condition is satisfied, communication performance may be significantly deteriorated depending on the structure of the product.

Control No.	Control name
(2/3)	Antenna application note

Other module mounting examples

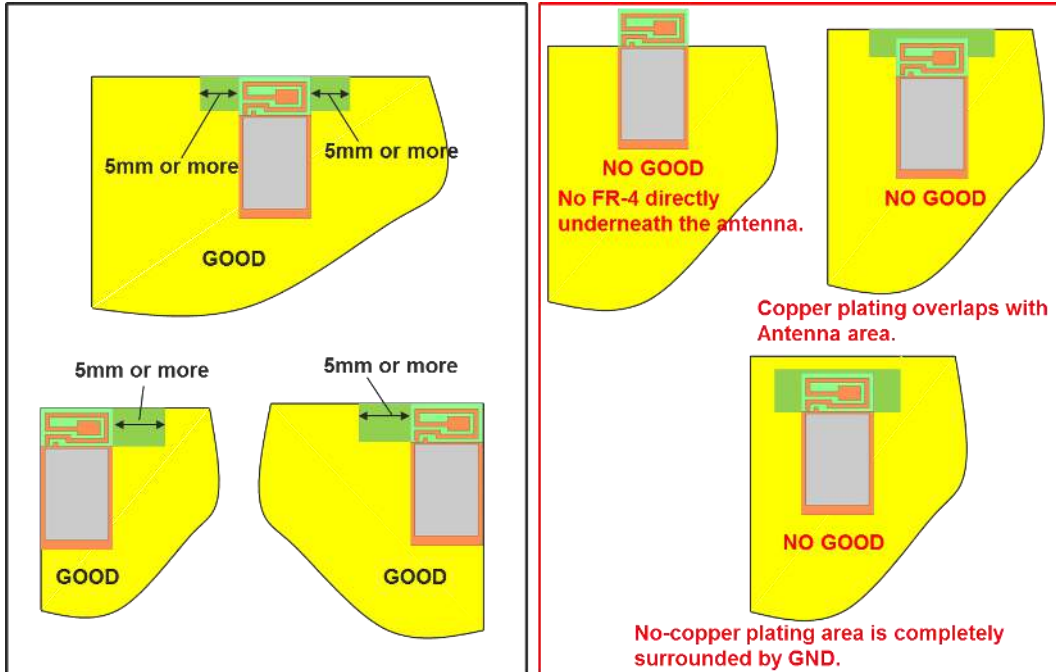

Placement of resin or plastic parts

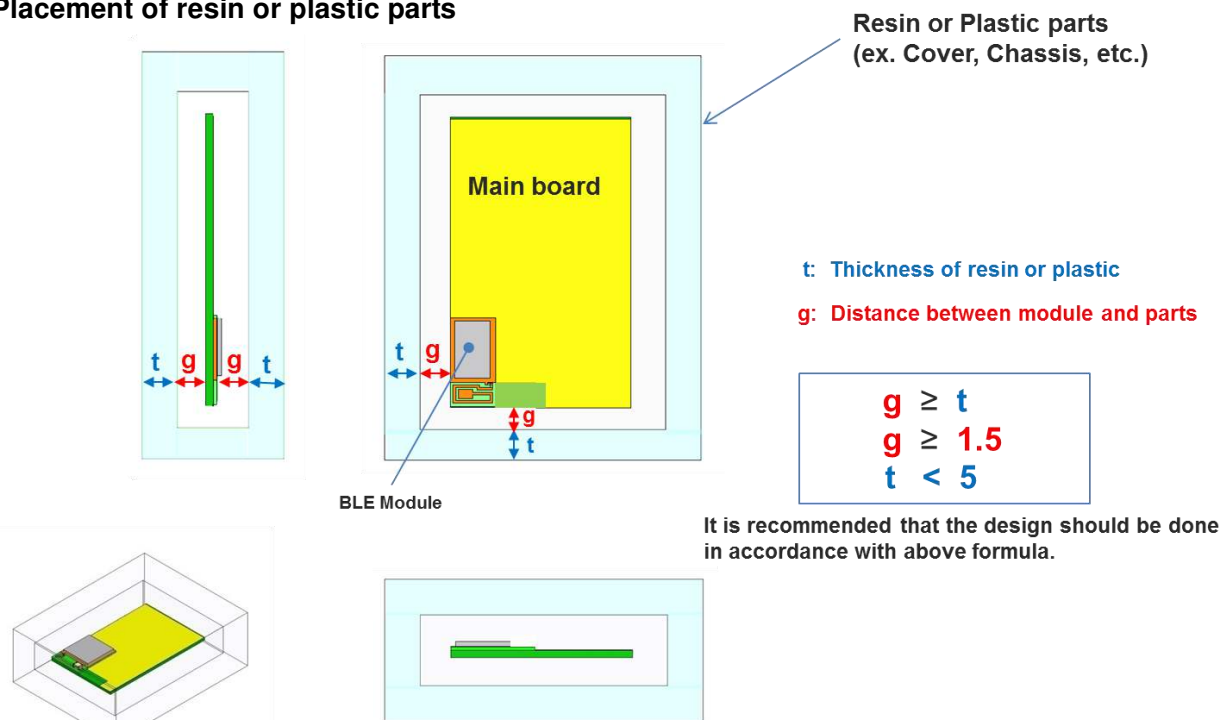

Please do not apply molding over the antenna area of BLE module.

Control No. (3/3)	Control name Antenna application note
--------------------------	--

Directional characteristics example (when mounted on evaluation board)

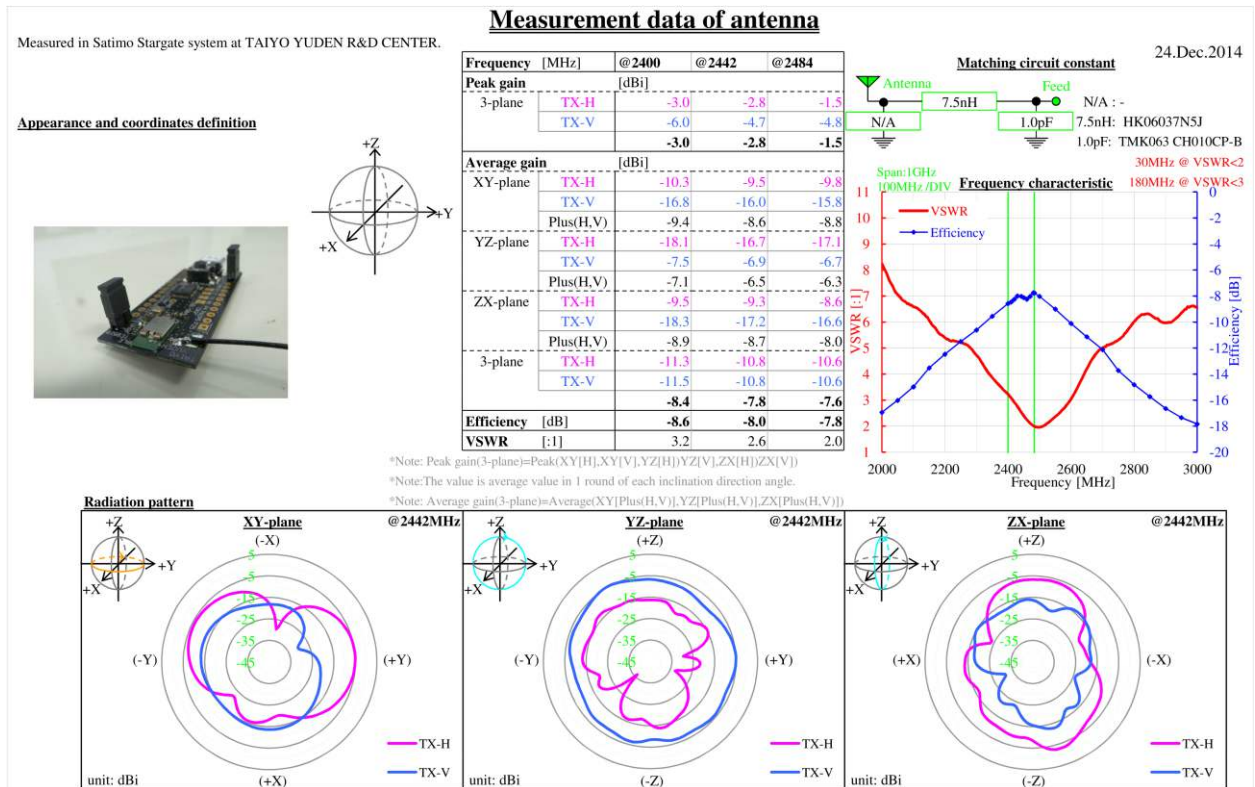

About this Application Note

- This Application Note has been prepared as a reference material to help obtaining the antenna performance mounted on BLE module better while it is not guaranteed or assured to obtain better communication performance and distance.
- This product “BLE module” has been certified and matching circuit constant for antenna within module cannot be changed when ambient environment condition changes. The product must be re-certified when matching circuit constant is changed.

Control No. (1/1)	Control name Design guide
----------------------	------------------------------

1. Power Up Sequence

VCC_NRF power supply rise time (0V to 1.8V) must not exceed 100ms.

2. Recommended Power Circuit

VCC_NRF is the main power supply (1.8 – 3.6V) for this module. The supply voltage range of VCC_NRF is 1.8V to 3.6V in LDO mode and 2.1V to 3.6V in DCDC mode. For more information of internal DC/DC converter operation, please refer to chapter 12.1.3 of "nRF51_Series_Reference_Manual v3.0" by Nordic Semiconductor. In case of the power supply voltage fluctuation by the load change is large, the module may not function properly. If an external regulator is used, the load change characteristic should be good in order to keep stable voltage as possible when the current is change.

3. Battery operation

When using a small battery (e.g. CR2032), a large capacitor (e.g.100uF low leakage capacitor) should be placed near the battery. This will reduce the voltage drop especially when the module is operated at low temperatures

4. Pattern Design Guide

4-1. Power Supply System

Power supply bypass capacitors should be placed close to the VCC_NRF pin of the module. The VCC_NRF trace should be greater than 0.5mm and a bigger a via diameter is recommended.

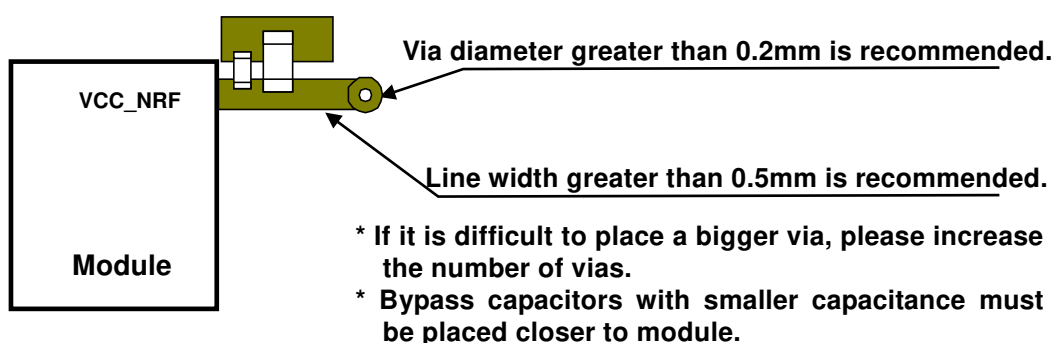

4-2. Bypass Capacitor Layout

A parallel combination of a small capacitance (about 10pF) and a large capacitance (1uF to 10uF) is recommended for bypass capacitors. The GND of the bypass capacitor should be placed close to an adjacent module GND to ensure the shortest closed loop.

4-3. GND Pattern

Power supply bypass capacitor GND should be placed in proximity of module GND. Wide GND area must be provided to ensure isolation for each layer.

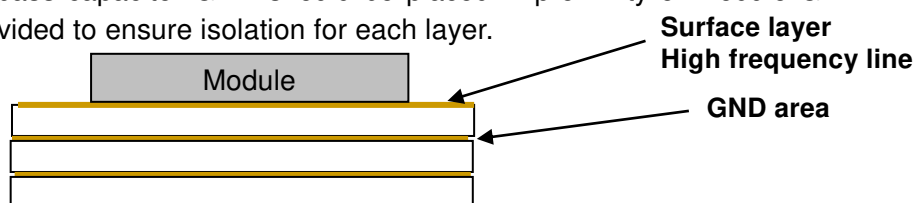

GND pattern of each layer should be connected to GND area with large number of via.

Control No. (1/1)	Control name Notes
----------------------	-----------------------

Clock frequency

The evaluation board included with the Nordic Development Kit uses a 16MHz clock. Therefore the sample code from Nordic is designed to be used with a 16MHz clock. On the other hand, the EYAGJN series module uses a 32MHz system clock, making it incompatible with the Nordic sample code (i.e. sample code does not configure HFCLK: XTALFREQ register for 32MHz). To fix this issue, we need to write the value 0xFFFFFFFF00 to the UICR (User Information Configuration Register) at address 0x10001008. Please note that the UICR is erased whenever you download a SoftDevice.

The UICR can be written by using the debug tools:

```
nrfjprog.exe --snr <your_jlink_debugger_serial_number> --memwr 0x10001008 --val 0xFFFFFFFF00
```

Or the following code can be added to the SystemInit function in the system_nRF51.c file, right before launching the TASK_HFCLKSTART task:

```
if (*(uint32_t *)0x10001008 == 0xFFFFFFFF)
{
    NRF_NVMC->CONFIG = NVMC_CONFIG_WEN_Wen << NVMC_CONFIG_WEN_Pos;
    while (NRF_NVMC->READY == NVMC_READY_READY_Busy){}
    *(uint32_t *)0x10001008 = 0xFFFFFFFF00;
    NRF_NVMC->CONFIG = NVMC_CONFIG_WEN_Ren << NVMC_CONFIG_WEN_Pos;
    while (NRF_NVMC->READY == NVMC_READY_READY_Busy){}
    NVIC_SystemReset();
    while (true){}
}
```

32kHz Clock

This module does not installed 32.768kHz crystal. In case of operating without external crystal, please use following example code in order to enable internal 32.768kHz RC oscillator (32k RCOSC). The content may change depending on the SDK you use.

```
SOFTDEVICE_HANDLER_INIT(NRF_CLOCK_LFCLKSRC_RC_250_PPM_TEMP_1000MS_CALIBRATION, false);
```

Note that when you choose to use the RC oscillator, it will add around 10uA average current consumption compared to a 20ppm external crystal.

ANT specification requires +/-50ppm accuracy for 32.768kHz clock. There is a possibility that the internal RC oscillator does not meet to the specification.

その他、注意事項について (Precautions)

- 弊社製品のご使用に際しては、使用する機器に実装された状態および実際の使用環境での評価および確認を必ず行ってください。
- 当仕様書に記載の製品は、一般的な電子機器【AV機器、OA機器、家電製品、事務機器、情報・通信機器（携帯電話、パソコンなど）】で使用されることを意図されています。従いまして、生命または身体に直接危害を及ぼす可能性のある機器【輸送用機器（自動車駆動制御装置、列車制御装置、船舶制御装置など）、交通用信号機器、防災機器、医療用機器、公共性の高い情報通信機器（電話交換機、電話・無線・放送などの基地局）】などへのご使用をご検討の場合は、必ず事前に弊社までお問い合わせをお願いします。
また、高度の安全性や信頼性が求められる機器【宇宙用機器、航空用機器、原子力用制御機器、海底用機器、軍用機器など】につきましては、弊社製品をご使用されないようお願いします。
なお、一般的な電子機器においても安全性や信頼性の要求が高い機器、回路などに弊社製品をご使用になる場合には、十分な安全性評価を実施され、必要に応じて設計時に保護回路などを追加していただくことをお勧めします。
弊社の書面による事前の承諾を得ることなく、前述の弊社への問い合わせが必要な機器または弊社が使用を禁止する機器に当仕様書に記載の製品を使用したことによりお客様または第三者に生じた損害に関して、弊社は一切の責任を負いかねますのでご了承ください。
- 弊社製品を使用したことにより、第三者の知的財産権などの権利に関わる問題が発生した場合、弊社はその責任を負いかねます。また、これらの権利の実施権許諾を行うものではありませんのでご了承ください。
- 弊社製品の保証範囲につきましては、別途書面による契約がない限り、納入された弊社製品単体の保証に限られ、弊社製品の故障や瑕疵から誘発される損害に関して、弊社は一切の責任を負いかねますのでご了承ください。
- 当仕様書に記載内容につきましては、弊社の営業所・販売子会社・販売代理店（いわゆる「正規販売チャンネル」）からご購入いただいた弊社製品に適用します。上記以外からご購入いただいた弊社製品に関しては適用対象外とさせていただきますのでご了承ください。
- 輸出注意事項
当仕様書に記載の製品の一部には、輸出の際に「外国為替及び外国貿易法」並びに米国の輸出管理関連法規などの規制をご確認の上、必要な手続きをお取りいただく必要のある製品があります。ご不明な場合には弊社までお問い合わせください。
- Please conduct validation and verification of our products in actual condition of mounting and operating environment before using our products.
- The products listed in this specification are intended for use in general electronic equipment (e.g., AV equipment, OA equipment, home electric appliances, office equipment, information and communication equipment including, without limitation, mobile phone, and PC). Please be sure to contact TAIYO YUDEN for further information before using the products for any equipment which may directly cause loss of human life or bodily injury (e.g., transportation equipment including, without limitation, automotive powertrain control system, train control system, and ship control system, traffic signal equipment, disaster prevention equipment, medical equipment, highly public information network equipment including, without limitation, telephone exchange, and base station).
Please do not incorporate our products into any equipment requiring high levels of safety and/or reliability (e.g., aerospace equipment, aviation equipment, nuclear control equipment, undersea equipment, military equipment).
When our products are used even for high safety and/or reliability-required devices or circuits of general electronic equipment, it is strongly recommended to perform a thorough safety evaluation prior to use of our products and to install a protection circuit as necessary.
Please note that unless you obtain prior written consent of TAIYO YUDEN, TAIYO YUDEN shall not be in any way responsible for any damages incurred by you or third parties arising from use of the products listed in this specification for any equipment requiring inquiry to TAIYO YUDEN or prohibited for use by TAIYO YUDEN as described above.
- Please note that TAIYO YUDEN shall have no responsibility for any controversies or disputes that may occur in connection with a third party's intellectual property rights and other related rights arising from use of our products. TAIYO YUDEN grants no license for such rights.
- Please note that unless otherwise agreed in writing, the scope of warranty for our products is limited to the delivered our products themselves and TAIYO YUDEN shall not be in any way responsible for any damages resulting from a fault or defect in our products.
- The contents of this specification are applicable to our products which are purchased from our sales offices or authorized distributors (hereinafter "TAIYO YUDEN's official sales channel"). Please note that the contents of this specification are not applicable to our products purchased from any seller other than TAIYO YUDEN's official sales channel.
- Caution for Export
Some of our products listed in this specification may require specific procedures for export according to "U.S. Export Administration Regulations", "Foreign Exchange and Foreign Trade Control Law" of Japan, and other applicable regulations. Should you have any questions on this matter, please contact our sales staff.