

PART NUMBER	REV	FIRST USED	POWER UNIT	FEED TYPE	DESCRIPTION
1852440-1	A	122500-1	LEADMAKER	AIR FEED	CUTS CARRIER
1852440-2	A	565435-5	BENCH MODEL K	AIR FEED	CUTS CARRIER
1852440-3	A	354500-1	BENCH MODEL G	AIR FEED	CUTS CARRIER
1852440-6	A	122500-1	LEADMAKER	AIR FEED	CONTINUOUS CARRIER
7-1852440-7	A	-	-	-	SPARE PARTS

- △ RECOMMENDED SPARE PARTS
- △ GREASE LIGHTLY
- △ GUARD MUST BE IN PLACE WHEN OPERATING APPLICATOR IN A BENCH MACHINE

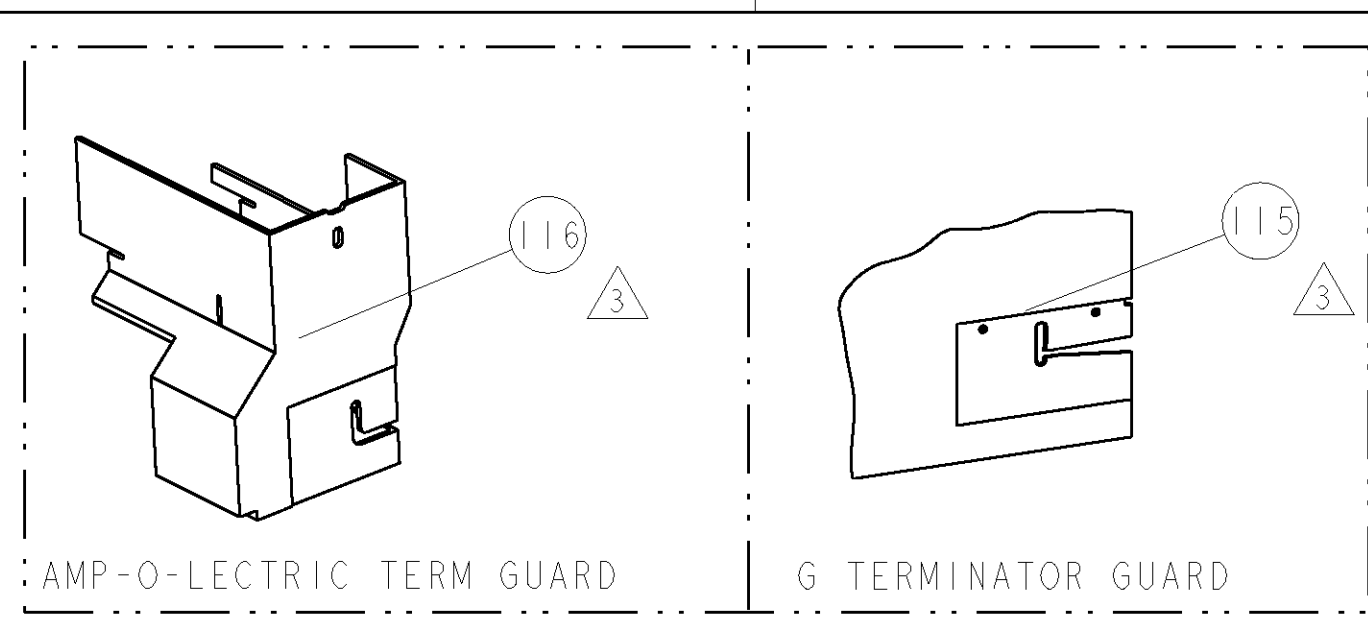
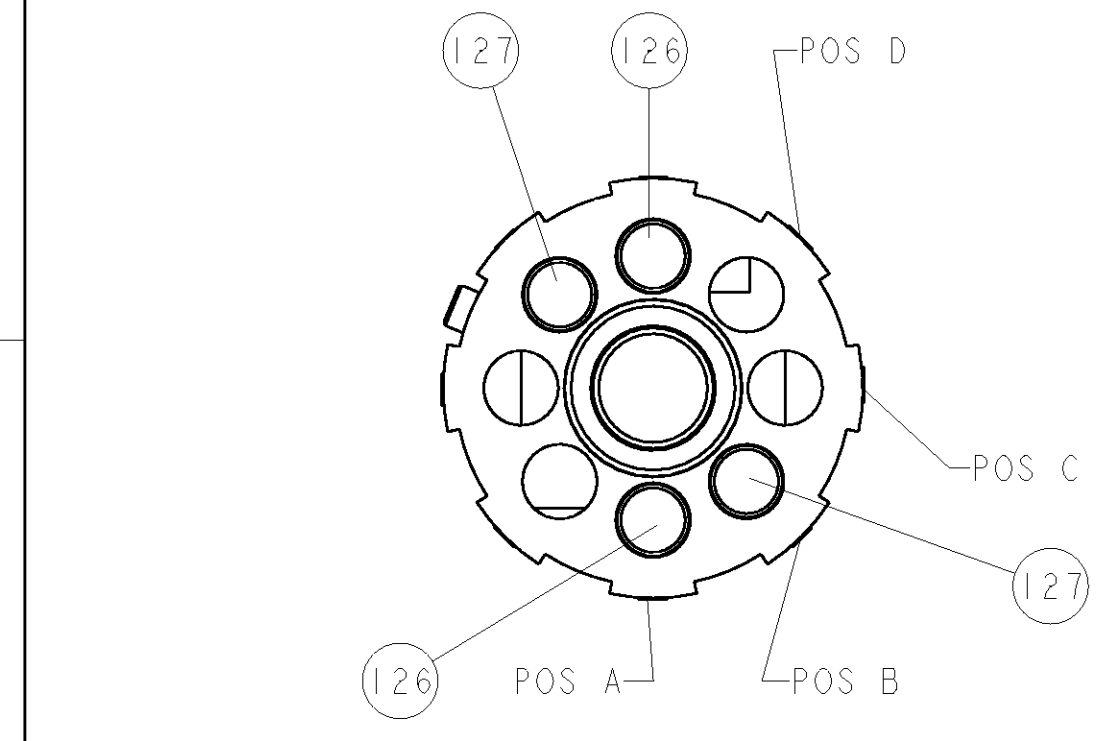

TERMINAL NAME: CHART 250 TERMINAL, FEMALE			
SOCKET	PIN	AMP TERMINAL - AMP CRIMP SPECS	
1438231-4	-		
3-1438231-2	-	PAD LTR	CRIMP HEIGHT
-	-	A	1.85±0.05mm [.073±.002]
-	-	B	1.70±0.05mm [.067±.002]
-	-	C	-
-	-	D	-
-	-	CRIMP	SIZE
-	-	WIRE	2.54mm [.100]
-	-	INSUL	3.56mm [.140]
WIRE STRIP LENGTH	TERM APPL SPEC	FEED	APPLICATOR INSTRUCTIONS
4.7-5.1mm	NONE	2.3mm	408-8040
			SET UP GAGE
			458637-1

LOC	DIST	REVISIONS			
A	66	P LTR	DESCRIPTION	DATE	DWN
		A	RELEASED	28MAR2007	LG TE

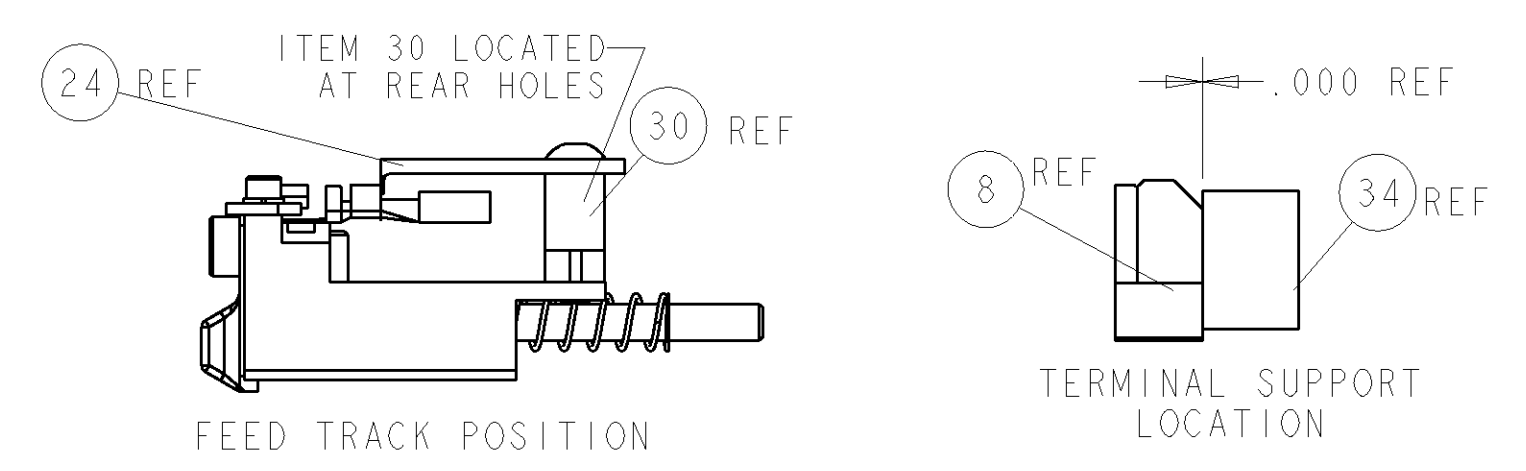
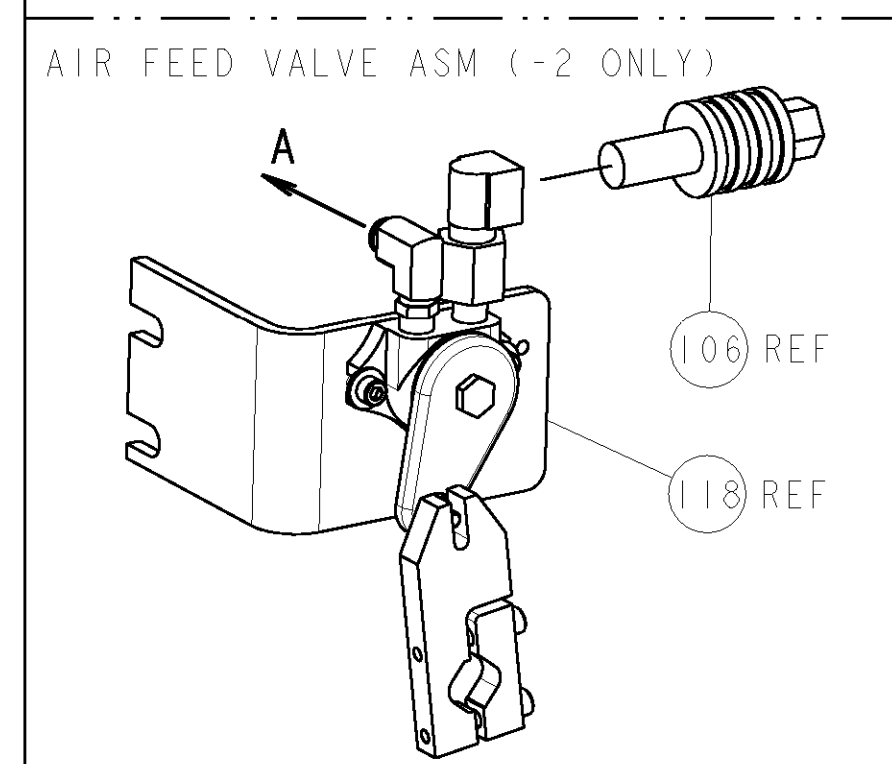
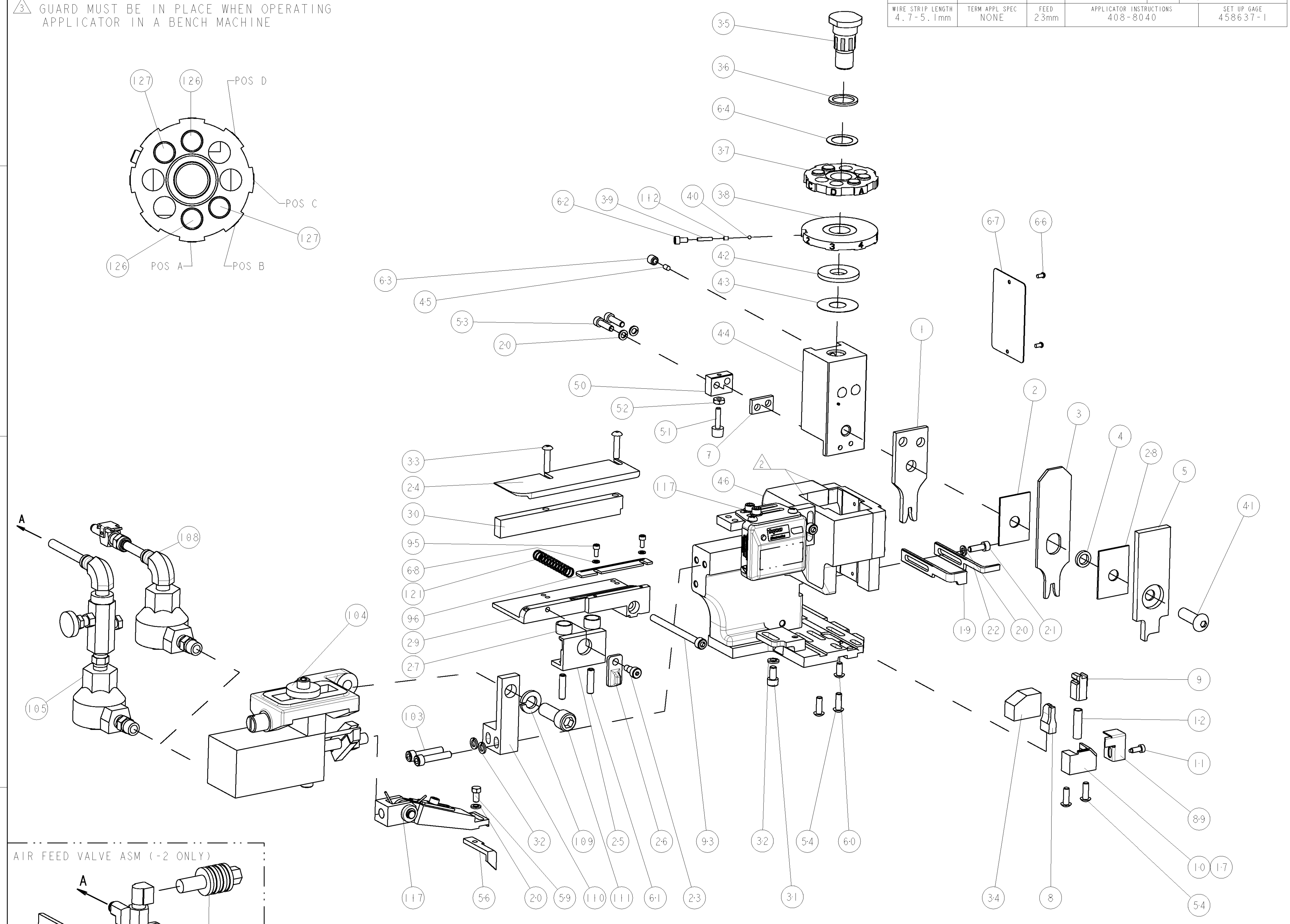

-	2	2	2	2	-	9-354778-5	PIN, WIRE DISC, .2970	127
-	2	2	2	2	-	8-354778-3	PIN, WIRE DISC, .2910	126
-	1	1	1	1	-	1-22281-8	SPRING, COMPRESSION	121
-	-	-	REF	-	-	692655-6	AIR FEED VALVE ASSEMBLY	118
-	1	1	1	1	-	461062-1	FEED FINGER ASSEMBLY	117
-	-	-	REF	-	-	455749-1	GUARD WINDOW	116
-	-	REF	-	-	-	679532-1	INSERT, GUARD	115
-	1	1	1	1	-	690603-1	SPRING ASSIST AMP-O-MATOR APPLICATOR	112
-77	-6	-3	-2	-1	U/M	PART NO	DESCRIPTION	ITEM NO

-	1	1	1	1	-	3-21001-5	SCR, SKT HD CAP 3/8-16 X 1.000	111
-	1	1	1	1	-	459610-3	MOUNT, FEED BRACKET	110
-	1	1	1	1	-	21024-8	WASHER, SPRG LOCK, REG 3/8	109
-	1	1	-	1	-	692655-7	AIR FEED VALVE ASSEMBLY	108
-	-	-	REF	-	-	24024-2	VALVE, SHUT OFF	106
-	-	-	1	-	-	692655-5	AIR FEED VALVE ASSEMBLY	105
-	1	1	1	1	-	461065-1	ASSEMBLY, AIR FEED	104
-	2	2	2	2	-	3-21000-9	SCR, SKT HD CAP 10-32 X 1.000	103
-	1	1	1	1	-	1-690438-0	FRONT STRIP GUIDE	96
-	2	2	2	2	-	1-21000-3	SCR, SKT HD CAP 4-40 X .250	95
-	1	1	1	1	-	8-21000-7	SCR, SKT HD CAP 10-32 X 2.500	93
-	1	1	1	1	-	318563-1	GUARD, FRONT CHIP	89
-	1	1	1	1	-	4088040	SF APPL INST 408-8040	72
-	1	1	1	1	-	217238-1	GENERAL INSTRUCTION PKG	71
-	2	2	2	2	-	21024-2	WASHER, SPRG LOCK, REG NO 4	68
-	1	1	1	1	-	461264-1	PLATE, IDENTIFICATION	67
-	2	2	2	2	-	21017-2	SCREW, DRIVE	66
-	1	1	1	1	-	986950-1	WASHER, FLAT PRECISION	64
-	1	1	1	1	-	21009-2	SCR, SET, SELF LOCKING 1/4-20 X .250	63
-	1	1	1	1	-	23030-1	SCR, SKT HD CAP 6-32 X .25	62
-	2	2	2	2	-	5-21006-6	SCR, SET, CUP POINT 10-32 X .750	61
-	1	1	1	1	-	22733-8	SCR, BHSC, SELF-LOCKING, 8-32 X .375	60
-	1	1	1	1	-	2-22603-0	SCR, HEX HD CAP 8-32 X .312	59
-	1	1	1	1	-	3-694433-7	FEED PAWL	56
-	4	4	4	4	-	2-21002-2	SCR, BTN SKT HD CAP 8-32 X .500	54
-	2	2	2	2	-	2-21000-8	SCR, SKT HD CAP 8-32 X .625	53
-	1	1	1	1	-	21018-5	NUT, HEX, REG 6-32	52
-	1	1	1	1	-	811242-2	BUMPER, HOLD DOWN	51
-	1	1	1	1	-	690753-1	SPACER, TONKER	50
-	1	1	1	1	-	1633399-1	APPL., BASIC AIR FEED SUB ASSY	46
-	1	1	1	1	-	690191-1	PLUG, NYLON	45
-	1	1	1	1	-	455673-1	RAM, SIDE FEED	44
-	1	1	1	1	-	690125-1	SHIM SUB-ASSY	43
-	1	1	1	1	-	690124-1	WASHER, RAM (.115)	42
-	1	1	1	1	-	7-21002-9	SCR, BTN SKT HD CAP 5/16-24 X 1.00	41
-	1	1	1	1	-	23241-6	BALL, STEEL	40
-	1	1	1	1	-	690170-1	SPRING, COMPRESSION	39
-	1	1	1	1	-	690142-1	DISC, INSULATION	38
-	1	1	1	1	-	354777-1	WIRE DISC, ASSEMBLY	37
-	1	1	1	1	-	22480-5	SPRING, COMPRESSION	36
-	1	1	1	1	-	690212-1	POST, RAM	35
-	1	1	1	1	-	690786-4	TERMINAL SUPPORT	34
-	2	2	2	2	-	2-21002-4	SCR, BTN SKT HD CAP 8-32 X .750	33
-	3	3	3	3	-	21024-5	WASHER, SPRG LOCK, REG NO 10	32
-	1	1	1	1	-	3-21000-4	SCR, SKT HD CAP 10-32 X .375	31
-	1	1	1	1	-	1320908-3	SPACER, STRIP GUIDE	30
-	1	1	1	1	-	1633087-1	PLATE, STRIP GUIDE	29
-	1	1	1	1	-	1-455888-0	SPACER, CRIMPER	28
-	2	2	2	2	-	1-22284-0	SPRING, COMPRESSION	27
-	1	1	1	1	-	356835-1	LEVER, DRAG RELEASE	26
-	1	1	1	1	-	240792-1	DRAG, TERMINAL	25
-	1	1	1	1	-	1320928-1	PLATE, STRIP GUIDE	24
-	1	1	1	1	-	21989-8	SCR, SKT HD SHLDR 3/16 DIA X .250	23
-	1	1	1	1	-	690472-2	STRIPPER	22
-	2	2	2	2	-	2-21000-7	SCR, SKT HD CAP 8-32 X .500	21
-	4	4	4	4	-	21024-4	WASHER, SPRG LOCK, REG NO 8	20
-	-	-	-	-	-	691353-1	STRIPPER	19
-	1	1	1	1	-	679625-1	SHEAR HOLDER, FRONT (NO CUT)	17
-	1	1	1	1	-	3-22280-3	SPRING, COMPRESSION	12
-	1	1	1	1	-	690461-1	STOP, SHEAR	11
-	-	-	1	1	-	690459-1	SHEAR HOLDER, FRONT	10
-	1	1	1	1	-	454276-1	FLOATING SHEAR, FRONT	9
1	1	1	1	1	-	1-1633111-5	ANVIL, COMBINATION .100	8
-	1	1	1	1	-	5-240641-2	SPACER	7
-	1	1	1	1	-	2-455889-0	DEPRESSOR, SHEAR	5
-	1	1	1	1	-	1-238011-0	BLOCK, CRIMPER SPACER	4
1	1	1	1	1	-	7-456134-7	CRIMPER, INSULATION F PREMIUM	3
-	1	1	1	1	-	455888-9	SPACER, CRIMPER	2
1	1	1	1	1	-	3-456407-3	CRIMPER, WIRE PREMIUM	1

THIS DRAWING IS UNPUBLISHED. RELEASED FOR PUBLICATION. COPYRIGHT 20 BY TYCO ELECTRONICS CORPORATION. ALL RIGHTS RESERVED.

LOC A DIST 66

REVISIONS

DATE 28MAR2007

DESCRIPTION SIDE FEED HDM APPLICATOR

TYCO Electronics Tyco Electronics Harrisburg, PA 17105-3608

SCALE 3:5 SHEET 1 OF 1 REV A

CUSTOMER VIEWABLE ASSEMBLY