

# **i3000s/i2000 Flex**

## *AC Current Probe*

### *Instruction Sheet*







#### **Introduction**

The i3000s 24 Flex, i3000s 36 Flex, and i2000 Flex AC Current Probes (hereafter referred to as “the Probe”) are used with oscilloscopes, digital multimeters, recorders or data loggers. The i3000s probes can be used to measure AC current up to 3000 A. The i2000 can be used to measure AC current up to 2000 A. The flexible measuring head allows current measurements on conductors that are hard to reach or inaccessible using typical clamp-on current probes.

The Probes provide a low-voltage (3 V AC for i3000s models, and 2 V AC for i2000) output that is proportional to the current being measured. The Probes provide full-scale direct readings for 30 A, 300 A, and 3000 A when using the i3000s models, and 20 A, 200 A, and 2000 A when using the i2000.

#### **Symbols**

The following table shows the symbols used on the product and/or in this manual.

<b>Symbol</b>	<b>Description</b>
	Do not dispose of this product as unsorted municipal waste. Contact Fluke or a qualified recycler for disposal.
	Important Information. Refer to the manual.
	Double/Reinforced insulation.
	Do not apply around or remove from the HAZARDOUS LIVE conductors.
	Complies with the relevant European standards.
	Conforms to Underwriters' Laboratory, Inc.

## ***Safety Instructions***

In this instruction sheet, a **Warning** identifies conditions and actions that pose hazard(s) to the user. A **Caution** identifies conditions and actions that may damage the calibrator or the test instruments.

### **⚠️⚠️ Warning**

**To avoid electric shock or personal injury:**

- **Use the Probes only if qualified.**
- **Use caution during installation and use of the Probe; high voltages and currents may be present in circuit under test.**
- **Have maintenance performed by only qualified service personnel.**
- **Protect the probe against water and humidity.**
- **Wear protective clothing and gloves as required.**
- **Do not install this product on live conductors. Always de-energize the circuit under test before installing the flexible measuring head.**
- **Always inspect the electronics unit, connecting cable, and flexible measuring head for damage before using the Probe.**
- **Do not use the Probe if damaged.**
- **Always connect Probe to display device before installing the flexible measuring head.**
- **Never change batteries while measurement head is installed on conductor.**
- **Never connect or disconnect the external power supply while the measurement head is installed on a conductor.**
- **Use only the provided original or specified accessories.**
- **Use the Current Probe only as specified in the operating instructions; otherwise the current probe's safety features may not protect you.**

- **Adhere to local and national safety codes. Individual protective equipment must be used to prevent shock and arc blast injury where hazardous live conductors are exposed.**
- **CAT III equipment is designed to protect against the transients in the equipment in fixed equipment installations, such as distribution panels, feeders and short branch circuits, and the lighting systems in large buildings.**

## **Specifications**

### **Electrical Characteristics**

Measuring ranges

i3000s (24 and 36 Flex)	30 A/300 A/3000 A AC, switch selectable
i2000 Flex	20 A/200 A/2000 A AC, switch selectable

Output sensitivity 100 mV/10 mV/1 mV per A  
(AC coupled)

Accuracy (at 25 °C)  $\pm 1$  % of range (45 – 65 Hz)

Frequency range

i3000s (24 and 36 Flex)	10 Hz to 50 kHz (-3 dB)
i2000 Flex	10 Hz to 20 kHz (-1 dB)

Phase error  $< \pm 1^\circ$  (45 – 65 Hz),  
 $\pm 10^\circ$  (at 20 kHz)

Linearity  $\pm 0.2$  % of reading from  
10 %  
- 100 % of range

Position sensitivity  $\pm 2$  % of range with cable  
>25 mm (1") from the  
coupling

External field  $\pm 1$  % of range with cable  
>200 mm (8 in) from the  
head

Minimum load 100 k $\Omega$  for specified  
accuracy

Noise 8 mV RMS (0.3 % of  
range) in 30 A range  
2 mV RMS (0.1 % of  
range) in 300 A and  
3000 A

Gain variation	±0.08 %/°C
Operating temperature	
i3000s (24 and 36 Flex)	-20 to +85 °C (-4 to 185 °F)
i2000 Flex	0 to 70 °C (32 to 158 °F)
Storage temperature	
i3000s (24 and 36 Flex)	-20 to +85 °C (-4 to 185 °F)
i2000 Flex	0 to 70 °C (32 to 158 °F)
Temperature coefficient:	± 0.08 % of reading / °C
Operating humidity:	15 to 85 % (non condensing)C
Altitude:	2000 m
Power supply	Two AA NEDA15A, MN1500, IEC LR6 alkaline batteries (all probes) Or an optional Class II external power supply (+3 V) (i3000 and i3000s)

Battery life	
i3000s (24 and 36 Flex)	400 hours typical
i2000 Flex	200 hours typical
Low battery	Indicated by a red LED

### ***General Characteristics***

Enclosure	IP5X flame retardant UL94-VO rated
Material	Valox 357
Output con.	
i3000s (24 and 36 Flex)	Coaxial cable with a male safety BNC connector. BNC to Banana plug adaptor (supplied)
i2000 Flex	0.5 meter cable with 4 mm safety plugs
Weight	0.19 kg (0.4 lb)
Safety	BS EN 61010-1, 600 V CAT III Pol. Deg 2
EMC	BS EN 61326
Dimensions	116 (l) x 68.5 (w) x 30 (d) mm 4.57 (l) x 2.71 (w) x 1.18 (d) in

## **Measuring Head Characteristics**

Cable length	
i2000, i3000s 24 Flex	610 mm (24 in), double insulated
i3000s 36 Flex	915 mm (36 in), double insulated
Cable diameter	14.3 mm (0.562 in)
Bend radius	38.1 mm (1.5 in)
Output cable	2 m long (78.7 in)
Coupling diameter	22.2 mm (0.875 in)
Material	TPE rubber, Polypropylene, UL94-VO rated
Operating temperature	- 20 °C to +90 °C (-4 °F to 194 °F)
Storage temperature	- 40 °C to +105 °C (- 40 °F to 221 °F)
Maximum relative humidity	85 %
Weight	0.18 kg (0.4 lb.)
Safety	BS EN 61010-1, 600 V CAT III Pol. Deg 2

# Operating Instructions

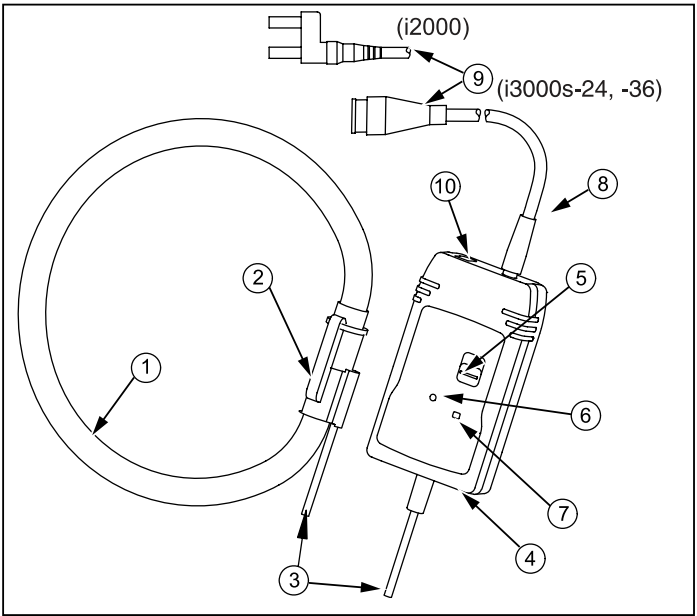

leb0001.eps

- ① Measuring head
- ② Measuring head coupling
- ③ Head output cable
- ④ Enclosure
- ⑤ Power on/Range selector
- ⑥ Battery low indicator
- ⑦ Power on indicator
- ⑧ Output cable
- ⑨ Safety BNC connector
- ⑩ External power supply input

## **Battery Installation**

### **⚠️⚠️ Warning**

**To avoid electric shock or personal injury:**

- **Never replace batteries with the flexible measuring head installed on the conductor to be tested or with the output connected to a display device.**
- **Never operate the unit without the battery cover installed.**

The Probes require two AA/MN1500/LR6 alkaline batteries for operation. The battery compartment is accessed from the rear end of the electronic enclosure.

The batteries must be replaced when the LED is lit continuously or when it fails to light up. Ensure that the Probe is away from any current carrying conductor and also that the output is disconnected from other equipment.

To install the battery:

1. Use a coin or a similar tool to turn the battery lock ( $\frac{1}{4}$  turn) until the dot aligns with the unlock symbol.
2. Remove the battery cover.
3. Install the batteries ensuring that correct polarity is observed.
4. Replace the battery cover and turn the battery lock until the dot aligns with the lock symbol.

## **External Power Supply (i3000s Models)**

An optional Class II external power supply is available from Fluke. The power supply is designed to ensure that the Probe continues to meet its specified safety standards. The usage of a power supply from another vendor is not recommended.

### **⚠️⚠️ Warning**

**To avoid electric shock or injury, never connect or disconnect the external power supply with the flexible measuring head installed on the conductor or with the output connected to a display device.**

## Measuring Current

### ⚠️⚠️ Warning

- **To avoid electric shock or injury, read Safety Instructions before operating this product**
- **Ensure that the conductor to be tested is de-energized**

To measure current:

1. Connect the output of the electronics to the input of an oscilloscope or other data recording device.

### ⚠️⚠️ Warning

**To avoid electric shock or injury, the flexible current probe is not for use on conductors with a potential of over 600 V.**

2. Wrap the flexible measuring head around the conductor to be tested in a close coupling manner.
3. Energize the circuit under test.
4. For most accurate measurement, centre the flexible head around the conductor.
5. Locate coupling away from the nearby conductors.

### ⚠️⚠️ Warning

**To avoid electric shock or injury:**

- **Do not use the flexible current probe to measure bare conductors unless wearing protective clothing suitable for high voltage work.**
- **Always use appropriate equipment for personal protection. When installed on bare conductors/busbars, the product must be within a suitable enclosure.**

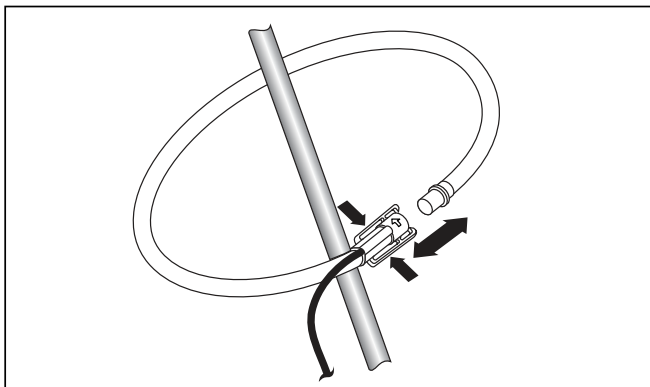



## **Operation**

To activate the unit, move the switch from 'Off' position to the required measuring range. If the value of current being measured is unknown, select the 3000 A (i3000s models) or 2000 A (i2000) current range and then reduce accordingly.

## **Battery Status**

Battery status is indicated by an LED on the front of the probe. This LED will flash one time when the unit is activated. The length of time the LED is lit will increase as battery life decreases. Momentary lighting of LED indicates batteries are good. Continuous lighting of LED indicates low battery and requires replacement at the earliest. No lighting of LED indicates batteries are dead and require replacement immediately.

## **Maintenance**

### **Warning**

**To avoid electric shock or injury, do not use Probe if damaged.**

Always inspect the electronics unit, connecting cable, and flexible measuring head for damage before use.

To avoid electric shock, keep the probes clean and free of surface contamination. Use Isopropyl alcohol to clean the electronics unit and measuring head. Make sure that the flexible measuring head, connecting cable, and electronic enclosure are dry before further use.

## ***LIMITED WARRANTY AND LIMITATION OF LIABILITY***

This Fluke product will be free from defects in material and workmanship for one year from the date of purchase. This warranty does not cover fuses, disposable batteries, or damage from accident, neglect, misuse, alteration, contamination, or abnormal conditions of operation or handling. Resellers are not authorized to extend any other warranty on Fluke's behalf. To obtain service during the warranty period, contact your nearest Fluke authorized service center to obtain return authorization information, then send the product to that Service Center with a description of the problem.

THIS WARRANTY IS YOUR ONLY REMEDY. NO OTHER WARRANTIES, SUCH AS FITNESS FOR A PARTICULAR PURPOSE, ARE EXPRESSED OR IMPLIED. FLUKE IS NOT LIABLE FOR ANY SPECIAL, INDIRECT, INCIDENTAL OR CONSEQUENTIAL DAMAGES OR LOSSES, ARISING FROM ANY CAUSE OR THEORY. Since some states or countries do not allow the exclusion or limitation of an implied warranty or of incidental or consequential damages, this limitation of liability may not apply to you.

Fluke Corporation  
P.O. Box 9090  
Everett, WA 98206-9090  
U.S.A.

Fluke Europe B.V.  
P.O. Box 1186  
5602 BD Eindhoven  
The Netherlands