

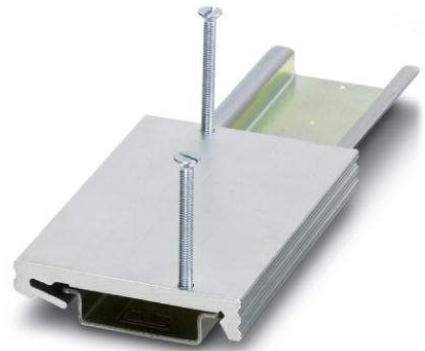

FL BT ADAPTER

Order No.: 2884949



<http://eshop.phoenixcontact.de/phoenix/treeViewClick.do?UID=2884949>

The DIN rail adapter is required to snap the Bluetooth devices FL BLUETOOTH AP, FL BT MOD IO AP, FL WLAN SPA and FL BT SPA onto a DIN rail. To do this, it is mounted on the respective device using the two enclosed screws.

Commercial data	
GTIN (EAN)	 4 046356 166645
sales group	K004
Pack	1 pcs.
Customs tariff	85176200
Catalog page information	Page 322 (NTK-2010)

Product notes

WEEE/RoHS-compliant since:
04/08/2008



<http://www.download.phoenixcontact.com>
Please note that the data given here has been taken from the online catalog. For comprehensive information and data, please refer to the user documentation. The General Terms and Conditions of Use apply to Internet downloads.

Diagrams/Drawings

Dimensioned drawing

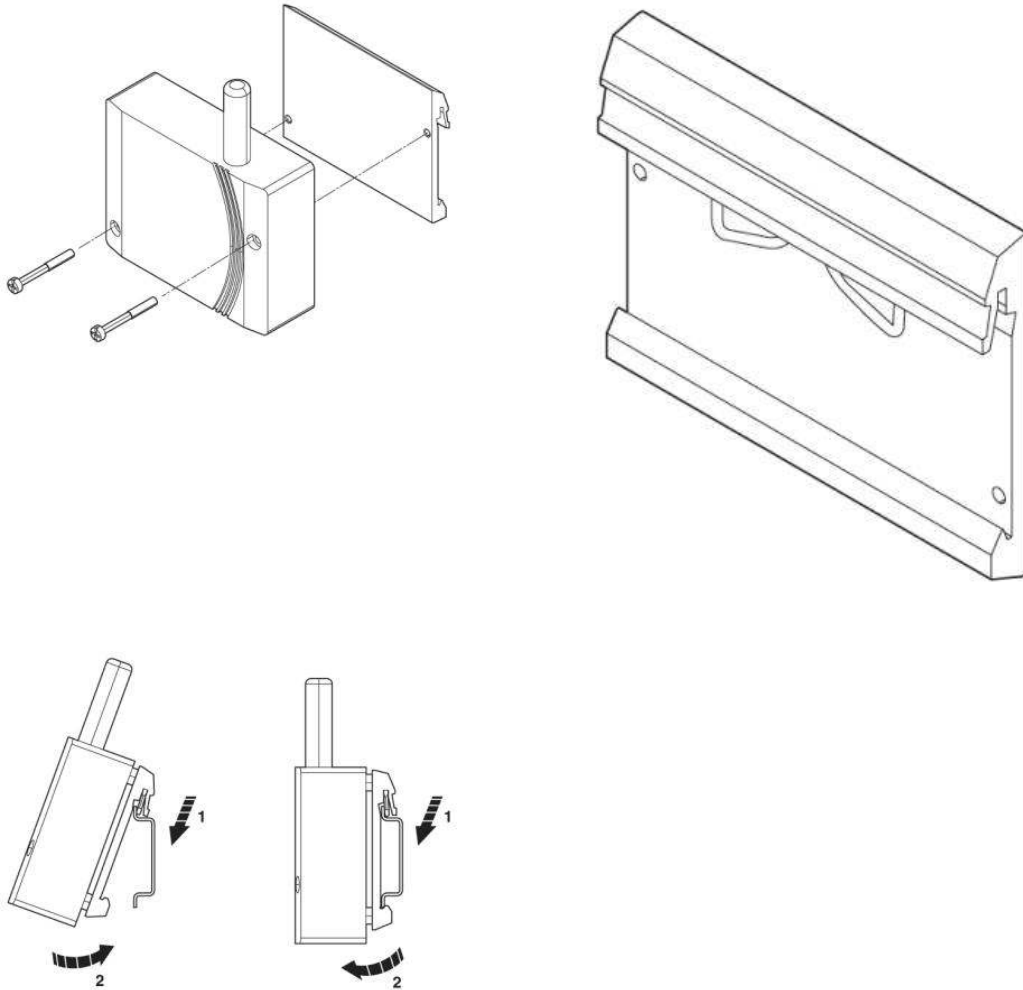

FL BT ADAPTER Order No.: 2884949

<http://eshop.phoenixcontact.de/phoenix/treeViewClick.do?UID=2884949>

Address

PHOENIX CONTACT Deutschland GmbH
Flachmarktstr. 8
32825 Blomberg, Germany
Phone +49 5235 3 12000
Fax +49 5235 3 41200
<http://www.phoenixcontact.de>



© 2011 Phoenix Contact
Technical modifications reserved;