

THIS DRAWING IS A CONTROLLED DOCUMENT FOR SOURIAU USA, INC. IT IS SUBJECT TO CHANGE WITHOUT NOTIFICATION. CONTACT THE DOCUMENT CONTROL CENTER FOR THE LATEST REVISION.

DWG. NO. **JBXHCOC**

MASS (g)	VOLUME (mm ³)
12.7	1825

ELECTRICAL:

EMI SHIELDING : SHIELDED FOR THE RANGE 55dB UP TO 100MHz

INSULATION RESISTANCE : >500MΩ PER ANSI-EIA-364-D METHOD 21

MAX. CURRENT RATING : SEE INSULATOR DRAWING

CONNECTOR TESTING : VOLTAGE SEE INSULATOR DRAWING

CONNECTOR WORKING : VOLTAGE SEE INSULATOR DRAWING

ENVIRONMENTAL:

ENDURANCE: 1000 CYCLES AS PER MIL-STD 1344A, METHOD 2016.1

SHOCK: 50 g , DURATION 6 ms; AS PER MIL-STD 1344A, METHOD 2004.1

VIBRATIONS: 10 TO 2000Hz g = 20g, AS PER MIL-STD 1344A, METHOD 2005.1

PROTECTION INDEX: IP 67 AS PER IEC 529

ROHS COMPLIANT

SALT MIST : 48Hr PER SAE AS 1344 METHOD 1001.1 CEI 529

OPERATING TEMPERATURE: -40°C TO +80°C (-40°F TO +176°F)

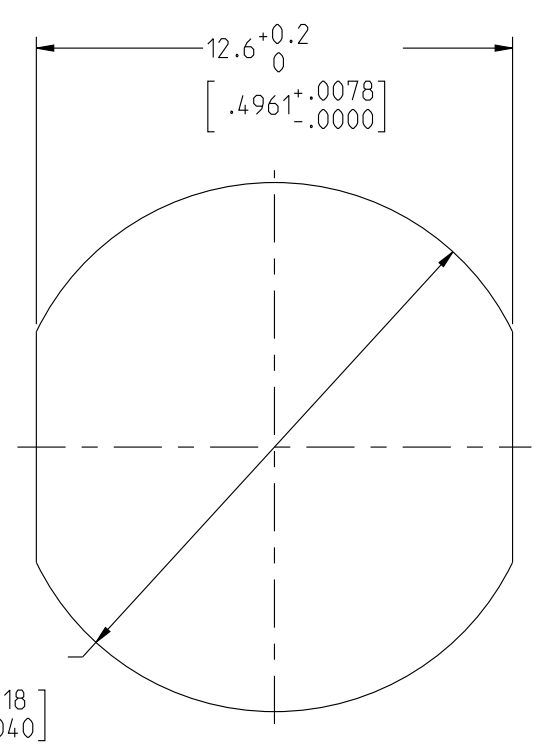

RECOMMENDED PANEL CUTOUT

NOTES:

1 RED BAND

MATERIAL:

OUTER SHELL & PANEL NUT : } BRASS
SHIELD RING & NUT : }

FINISH:

OUTER SHELL & PANEL NUT : CHROME

OTHER BRASS PARTS : NICKEL

T TOOLS

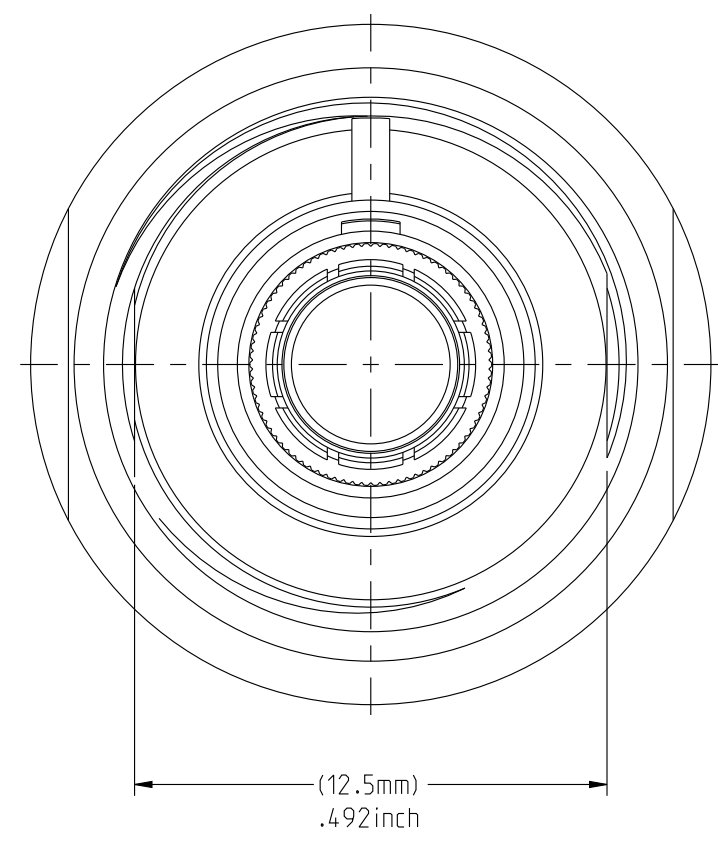

MATING SIDE VIEW

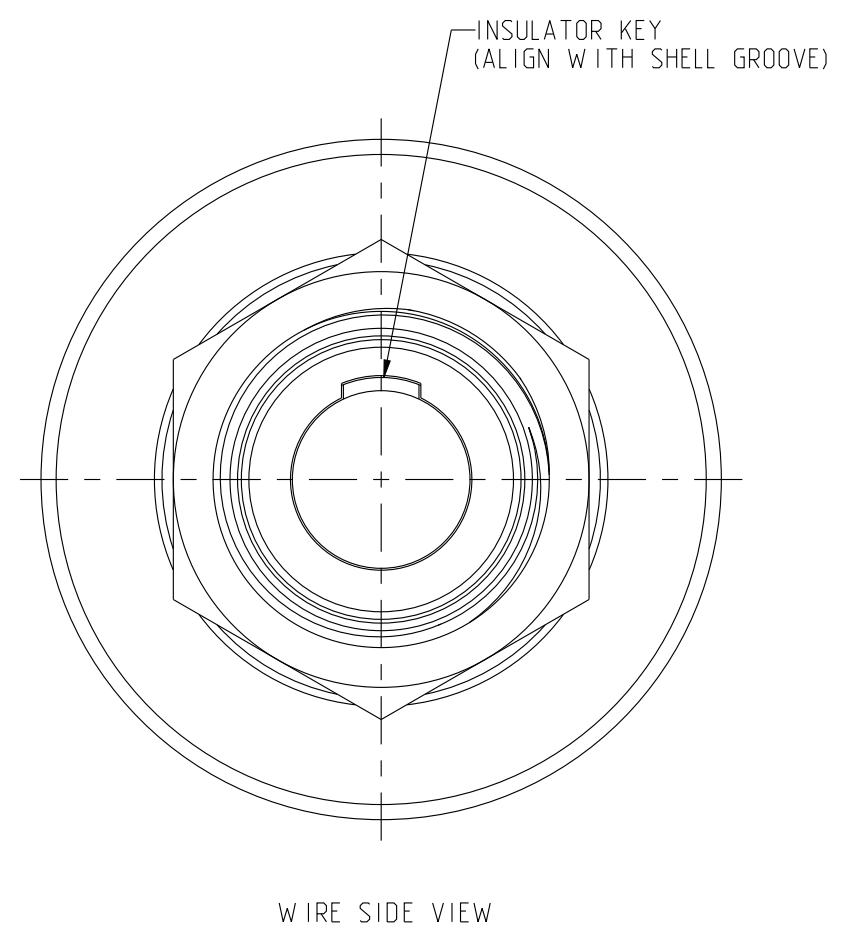
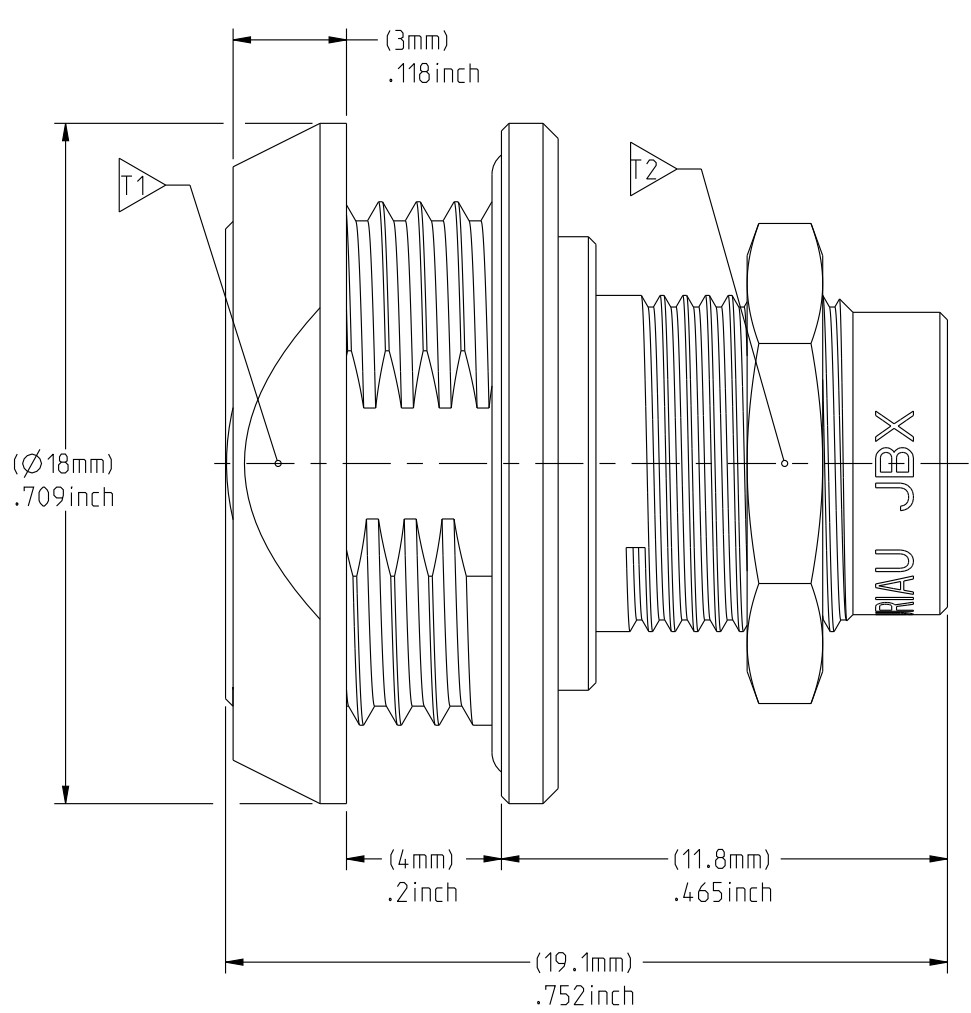

WIRE SIDE VIEW

	TOOLS (JAW DIMENSION)	ADVISED TORQUE IN Nm
T1	16	1.7
T2	11	0.7

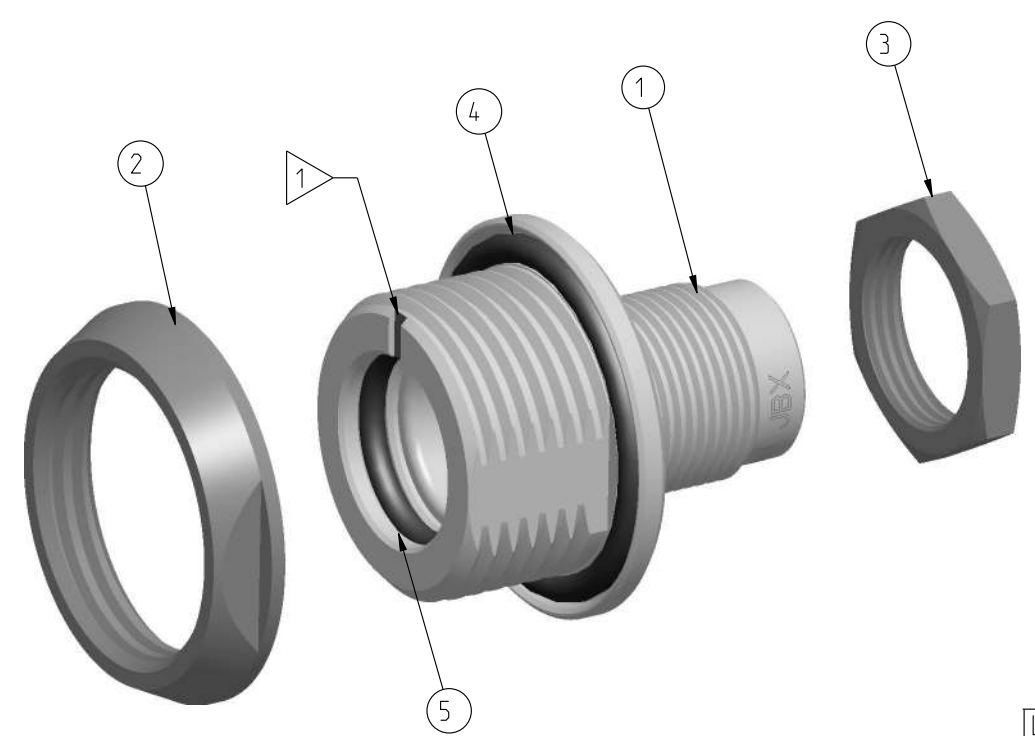

SCALE 3:1

PART LIST	
ITEM NO.	DESCRIPTION
1	SHELL
2	PANEL NUT
3	HEX NUT
4	O-RING, EXTERNAL
5	O-RING, INTERNAL

CATALOG NUMBER DESCRIPTION

JBX HC 0 XXXXX DSR

BASIC SERIES _____

SHELL TYPE _____

SHELL SIZE _____

KEYING _____

SEE INSULATOR DRAWING _____

OPTION _____

INSERT MATERIAL _____

COLLET OPTION _____

SURFACE PLATING _____

ORIGIN	COUNTRY	JURISDICTION	CLASSIFICATION
X	FR	Not listed	N/A
	US	EAR	ECCN =EAR99

These commodities, technology or software are exported from the United States in accordance with the Export Administration Regulations. Diversion contrary to U.S. law is prohibited.

LINEAR MEASURE:	mm (INCH)
THIRD ANGLE PROJECTION	
TOLERANCES UNLESS OTHERWISE SPECIFIED	
No. OF PLACES	mm [INCH]
WHOLE No.	±0.5 [±.02]
ONE PLACE	±0.2 [±.008]
TWO PLACES	±0.1 [±.004]
ANGLES ±1°	

DRAWING TITLE
JBX, SIZE 0, SEALED RECEPTACLE

CAT NO. **JBXHCOC**

CAGE NO: 09922 SIZE: C

CUSTOMER

INTERPRET THIS DRAWING IN ACCORDANCE WITH ASME Y14.5M - 1994.

SOURIAU
WWW.SOURIAU.COM

1 OF 1

APPROVAL	DRAWN: TJS	01-07-15
	CHKD : EV	01-07-15
	DSGN : EV	01-07-15
	MFG : DH	01-07-15
	QC : BB	01-07-15
	DRAWING SCALE: 5:1	
	DRAWING NO. REV	
	JBXHCOC	A

THE INFORMATION CONTAINED IN THIS DRAWING IS CONFIDENTIAL AND MAY NOT BE DISCLOSED WITHOUT WRITTEN CONSENT FROM SOURIAU USA, INC.

DWG. NO.
JBX01NSMPC

MALE INSULATOR, STRAIGHT PCB CONTACT

CONTACT LAYOUT	04	05	06	07	08
FRONT SIDE VIEW					
REAR SIDE VIEW					
CONTACT					
ISO VIEW					
CONTACT	ØC	0.7	0.7	0.5	0.5
	ØF	0.5	0.5	0.5	0.5
	MAX. AWG	-	-	-	-
	MAX. CURRENT RATING (A)	7	7	5	5
	CONTACT RESISTANCE (mΩ)	5	5	10	10
INSULATOR	NUMBER OF CAVITY	4	5	6	7
	MAX. CURRENT RATING	7	6.5	2.5	2.5
	TEST VOLTAGE (Vrms)	1350	800	680	680
	WORKING VOLTAGE (Vdc/Vrms)	660/460	400/260	320/220	320/220

CONTACT TYPE : M (MALE)
CONTACT TERMINATION : P (PCB)
MATERIAL :
 CONTACT: BRASS
 INSULATOR: PEEK
FINISH :
 CONTACTS: GOLD

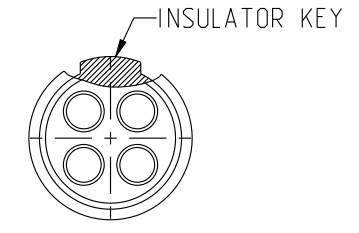

CATALOG NUMBER DESCRIPTION

JBXXX 0 XYYMP XXXX

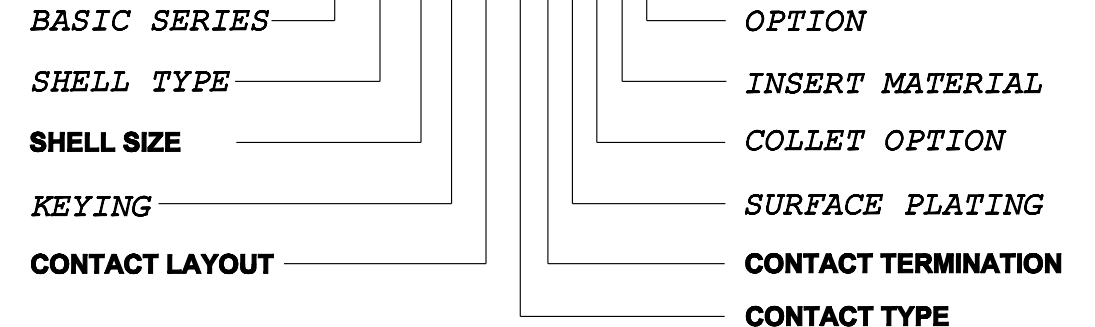

B	REVISED PER ECN 12286	RSK 06-10-15	EV 06-10-15
A	RELEASED PER ECN 12264	SKV 03-10-15	EV 03-10-15
REV	DESCRIPTION	BY DATE	CHKD DATE

DRAWING TITLE
JBX, SIZE O, MALE INSULATOR, PCB CONTACT

CAT NO. **JBX01NSMP**

CAGE NO: 09922 SIZE: B

CUSTOMER	SOURIAU	APPROVAL	DRAWN: SKV	02-02-15
			CHKD : EV	02-02-15
INTERPRET THIS DRAWING IN ACCORDANCE WITH ASME Y14.5M - 1994.	WWW.SOURIAU.COM		DSGN : EV	02-02-15
			MFG : DH	02-02-15
			QC : BB	02-02-15
			DRAWING SCALE: NA	
			DRAWING NO.	REV
			JBX01NSMPC	B
			1 OF 2	

THIS DRAWING IS A CONTROLLED DOCUMENT FOR SOURIAU USA, INC. IT IS SUBJECT TO CHANGE WITHOUT NOTIFICATION. CONTACT THE DOCUMENT CONTROL CENTER FOR THE LATEST REVISION.

THE INFORMATION CONTAINED IN THIS DRAWING IS CONFIDENTIAL AND MAY NOT BE DISCLOSED WITHOUT WRITTEN CONSENT FROM SOURIAU USA, INC.

ORIGIN	COUNTRY	JURISDICTION	CLASSIFICATION
X	FR	Not listed	N/A
	US	EAR	ECCN =EAR99

These commodities, technology or software are exported from the United States in accordance with the Export Administration Regulations. Diversion contrary to U.S. law is prohibited

LINEAR MEASURE: $\frac{mm}{INCH}$ mm (INCH)
 THIRD ANGLE PROJECTION

 TOLERANCES UNLESS OTHERWISE SPECIFIED
 No. OF PLACES mm [INCH]
 ONE PLACE ±3 [±.1]
 TWO PLACES ±0.5 [±.02]
 THREE PLACES ±0.25 [±.010]
 ANGLES ±1°

B

A

THIS DRAWING IS A CONTROLLED DOCUMENT FOR SOURIAU USA, INC. IT IS SUBJECT TO CHANGE WITHOUT NOTIFICATION. CONTACT THE DOCUMENT CONTROL CENTER FOR THE LATEST REVISION.

THE INFORMATION CONTAINED IN THIS DRAWING IS CONFIDENTIAL AND MAY NOT BE DISCLOSED WITHOUT WRITTEN CONSENT FROM SOURIAU USA, INC.

DWG. NO.
JBX01NSMPC

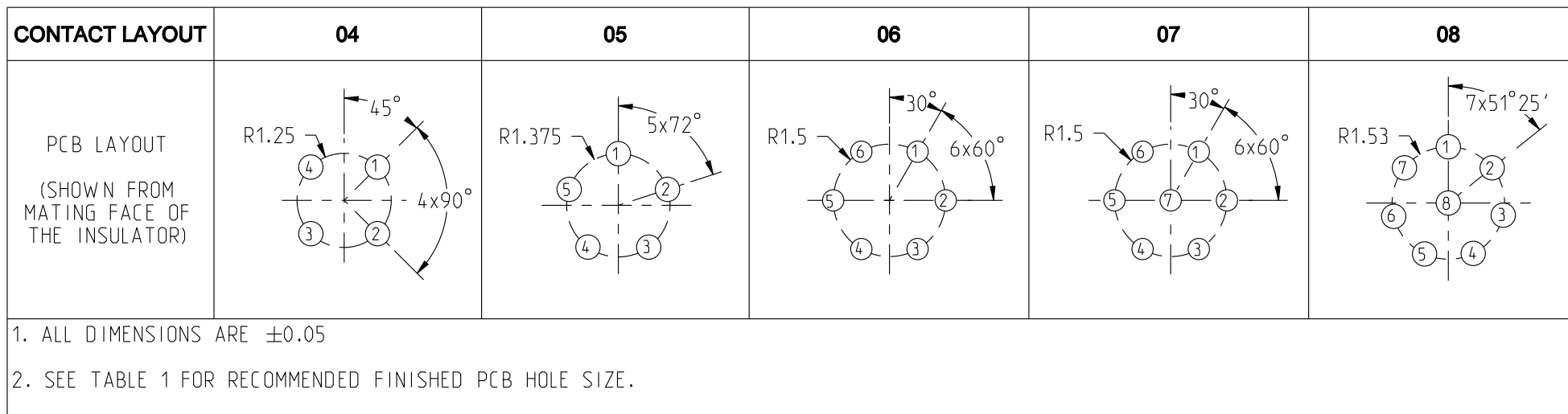

CONTACT PCB TAIL SIZE DIA	FINISHED PCB HOLE SIZE DIA
0.5	0.75

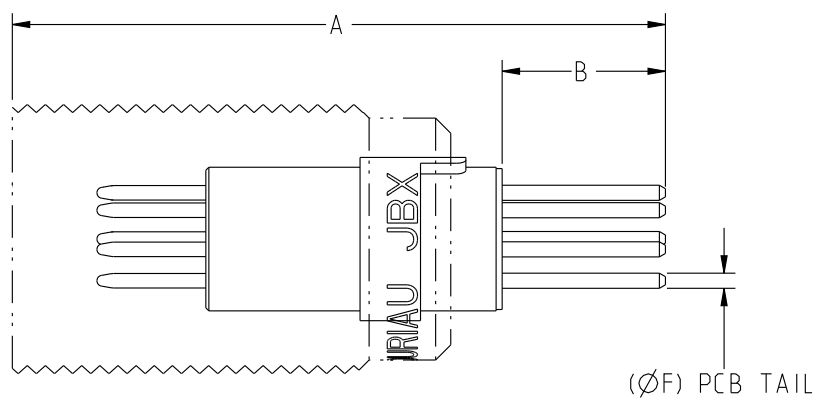

LAYOUT	04	05	06	07	08
A	24.3			21.6	
B	5.9			5.4	

ORIGIN	COUNTRY	JURISDICTION	CLASSIFICATION
X	FR	Not listed	N/A
	US	EAR	ECCN =EAR99

These commodities, technology or software are exported from the United States in accordance with the Export Administration Regulations. Diversion contrary to U.S. law is prohibited.

LINEAR MEASURE:	$\frac{mm}{INCH}$ mm (INCH)
THIRD ANGLE PROJECTION	
TOLERANCES UNLESS OTHERWISE SPECIFIED	
No. OF PLACES	mm [INCH]
ONE PLACE	$\pm 3 [\pm .1]$
TWO PLACES	$\pm 0.5 [\pm .02]$
THREE PLACES	$\pm 0.25 [\pm .010]$
ANGLES $\pm 1^\circ$	

DRAWING TITLE		JBX, SIZE O, MALE INSULATOR, PCB CONTACT	
CAT NO.		JBX01NSMP	
CAGE NO: 09922	SIZE: B	CUSTOMER SOURIAU WWW.SOURIAU.COM	
INTERPRET THIS DRAWING IN ACCORDANCE WITH ASME Y14.5M - 1994.			
APPROVAL		DRAWN: SKV 02-02-15	
		CHKD : EV 02-02-15	
		DSGN : EV 02-02-15	
		MFG : DH 02-02-15	
		QC : BB 02-02-15	
		DRAWING SCALE: NA	
		DRAWING NO.	REV
		JBX01NSMPC	B
		2 OF 2	

B

A