

**NOTE**



All numerical values are in metric units [with U.S. customary units in brackets]. Dimensions are in millimeters [and inches]. Unless otherwise specified, dimensions have a tolerance of  $\pm 0.13$  [ $\pm .005$ ] and angles have a tolerance of  $\pm 2^\circ$ . Figures and illustrations are for identification only and are not drawn to scale.

**1. INTRODUCTION**

This specification covers the requirements for application of AMP-LATCH Universal Input/Output (I/O) Pin Connectors with 0.64 mm [.025 in.] square pins on 2.54 mm [.100 in.] centers in the mating end. The connectors have insulation displacement contacts on 1.27 mm [.050 in.] centers for 28 through 26 AWG ribbon cable. Feed-through and end-of-line applications can be made with manual or pneumatically operated tooling.

Connectors are available in 10 through 64 individual contact positions. Each consists of a housing with contacts and a pre-assembled cover. They are available with or without slotted mounting ears.

Figure 1 provides contact features and terms used throughout this specification. Use these terms when corresponding with TE Connectivity (TE) Representatives to facilitate assistance.

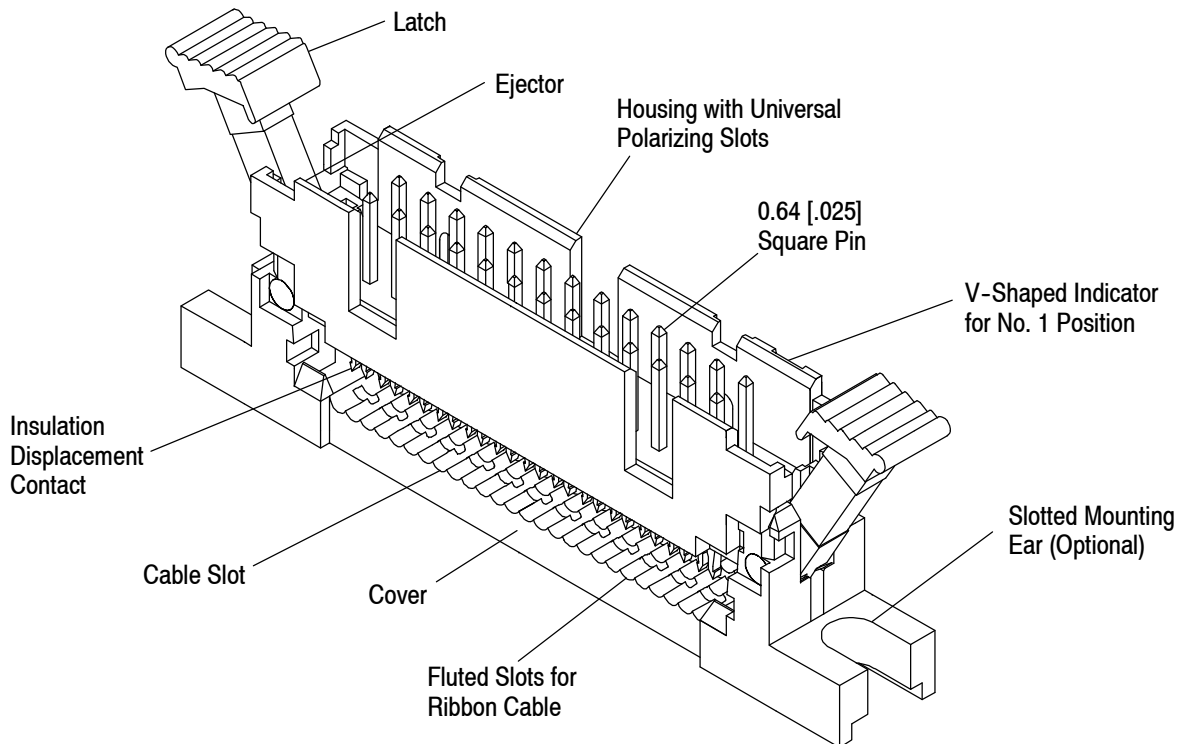

Figure 1

**2. REFERENCE MATERIAL**

**2.1. Revision Summary**

This paragraph is reserved for a revision summary covering the most recent additions and changes made to this specification which include the following:

- Update document to corporate requirements
- New logo

## 2.2. Customer Assistance

Reference Part Number 111506 and Product Code 0799 are representative numbers of AMP-LATCH Universal I/O Pin Connectors. Use of these numbers will identify the product line and expedite your inquiries through a service network established to help you obtain product and tooling information. Such information can be obtained through a local TE Representative or, after purchase, by calling the Tooling Assistance Center or the Product Information Center number at the bottom of page 1.

## 2.3. Drawings

Customer Drawings for each product part number are available from the service network. The information contained in Customer Drawings takes priority if there is a conflict with this specification or with any technical documentation supplied by TE.

## 2.4. Specifications

Product Specification 108-1336 covers test and performance requirements.

## 2.5. Instructional Material

The following list includes available instruction sheets (408-series) that provide assembly procedures for product, operation, maintenance and repair of tooling; and customer manuals (409-series) that provide setup, operation, and maintenance of machines.

<u>Document Number</u>	<u>Document Title</u>
408-6732	Pneumatic Auto-Cycle Unit 91112-3
408-7763	Pneumatic Applicator Frame Assemblies 91112-2 and 91112-7
408-7777	Manual Arbor Frame Assembly 91085-2
408-9720	AMP-LATCH Universal I/O Pin Connectors
408-9826	Base Assembly Universal Hand Tool 768339-1
408-9827	Base Assembly Universal Arbor Tool 768338-1
408-9828	AMP-LATCH Hand Tool Kit 768340-1 for Connector-Specific Kits
408-9836	Connector-Specific Kit 768344-1 for AMP-LATCH Universal I/O Pin Connectors
408-9846	AMP-LATCH Hand Tool Subassembly 768942-1 for Connector-Specific Kits
409-5873	R-Cam 4A Automatic Ribbon Cable Assembly Machine 318800-[ ]

## 3. REQUIREMENTS

### 3.1. Storage

#### A. Ultraviolet Light

Prolonged exposure to ultraviolet light may deteriorate the chemical composition used in connectors.

#### B. Shelf Life

The connectors should remain in the shipping containers until ready for use to prevent damage. The products should be used on a first in, first out basis to avoid storage contamination that could adversely affect signal transmissions.

#### C. Chemical Exposure

Do not store connectors near any chemicals listed below, as they may cause stress corrosion cracking in the components.

Alkalies	Ammonia	Citrates	Phosphates	Citrates	Sulfur Compounds
Amines	Carbonates	Nitrites	Sulfur	Nitrites	Tartrates

NOTE

*Where the above environmental conditions exist, phosphor-bronze contacts are recommended instead of brass if available.*



### 3.2. Panel Cutout

Connectors with mounting ears can be front or rear mounted to a panel. The mounting hole locations will be the same for both; however, a cutout must be made in the panel when rear mounting is used. See Figure 2.

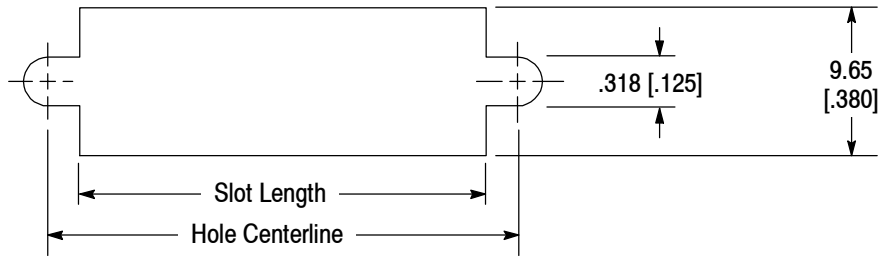

CONNECTOR CONTACT POSITIONS	CUTOUT	
	SLOT LENGTH	HOLE CENTERLINE
10	26.47 [1.042]	30.58 [1.204]
14	31.55 [1.242]	35.66 [1.404]
16	34.09 [1.342]	38.20 [1.504]
20	39.17 [1.542]	44.20 [1.704]
24	44.25 [1.742]	48.36 [1.904]
26	46.79 [1.842]	50.90 [2.004]
30	51.88 [2.042]	55.98 [2.204]
34	56.96 [2.242]	61.06 [2.404]
40	64.58 [2.542]	68.68 [2.704]
44	69.66 [2.742]	73.76 [2.904]
50	77.27 [3.042]	81.38 [3.204]
60	89.97 [3.542]	94.08 [3.704]
64	95.05 [3.742]	99.16 [3.904]

Figure 2

### 3.3. Intermateability

The connectors are designed to mate with AMP-LATCH Receptacle Connectors (such as Novo) and other industry standard receptacles having identical number of contact positions on 2.54 mm [.100 in.] centers and compatible polarization.

### 3.4. Cable Selection and Preparation

The connectors are designed for 28 through 26 AWG stranded (7-stranded), and solid conductors meeting the dimensional requirements provided in Figure 3. The only preparation requirement is the cable end must be cut squarely.

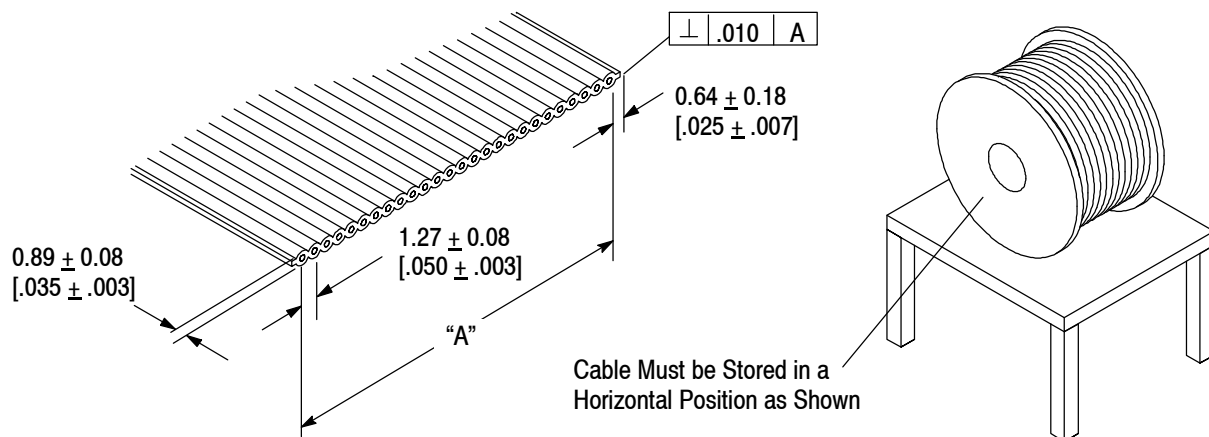

Figure 3

### 3.5. Keying (Military Applications)

Keying plugs can be installed in the connectors to prevent mismatching of compatible connectors. The keys must be installed in slots that have webbing in them. The tab latch must be toward the inside of the connector and the flat must be on the outside. See Figure 4.

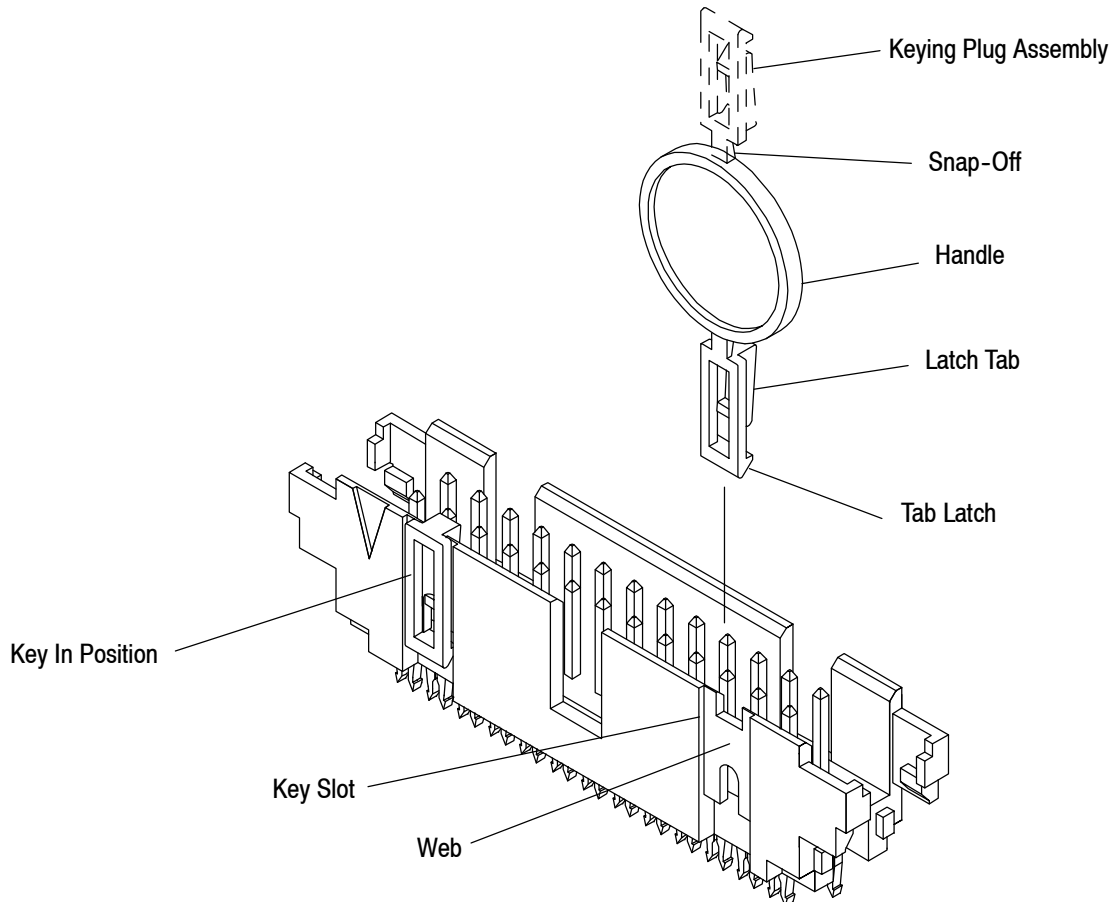

Figure 4

### 3.6. Mounting Hardware

Connectors with slotted mounting ears can be secured to a panel with commercially available 4-40 hardware such as screw, washers, and nuts, self-threading screws, rivets, etc.

### 3.7. Ejector Latch

All connectors are available with or without ejector latches and can be used with or without them. The ejector latches are designed to lock mating connectors together and to ease disengagement of mated connectors. They are available in three lengths to accommodate the three styles of connectors and can be purchased as a pre-installed connector component or they can be supplied separately for installation on connectors that were purchased without pre-installed latches. Latches of one size can easily be removed and replaced with another size to accommodate a different size connector.

When installing an ejector latch, the latch pivot pins must be held at a 15° angle and inserted into the cover pin slots until bottomed, then the latch must be rotated until it is perpendicular to the cover. See Figure 5.

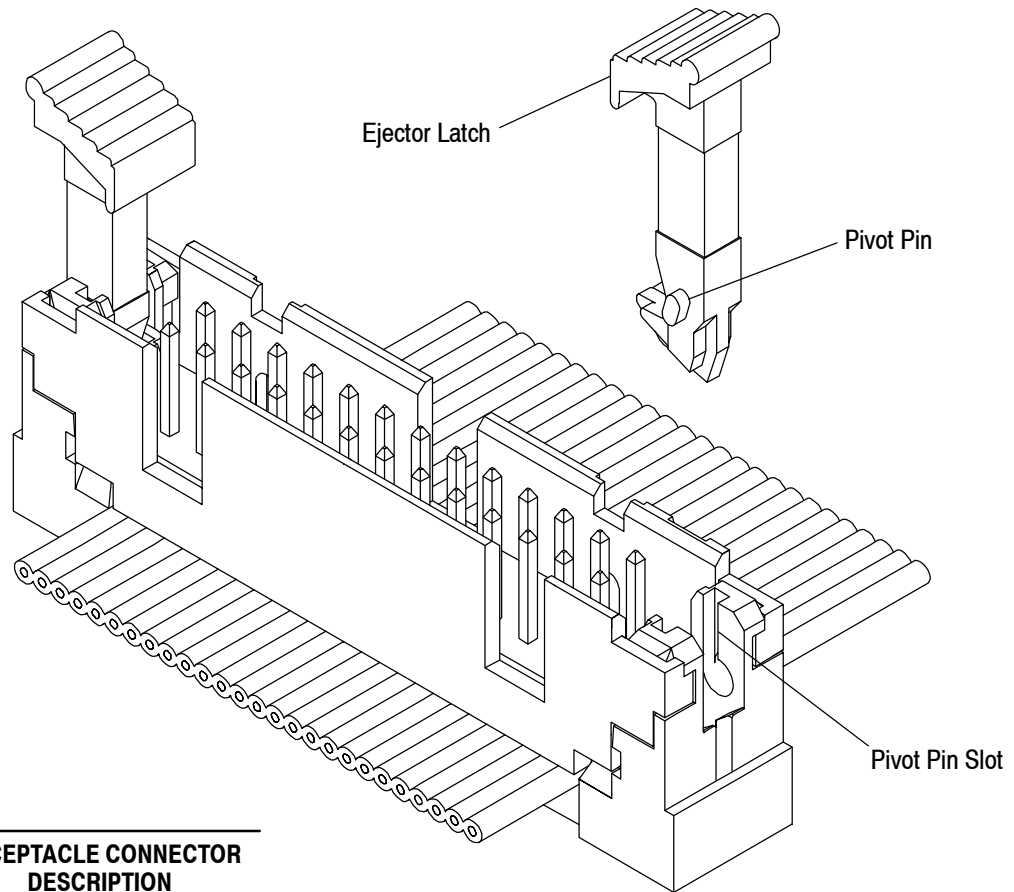

EJECTOR LATCH LENGTH	RECEPTACLE CONNECTOR DESCRIPTION
19.58 [.771]	Cover with Ejector Latch Slot
21.06 [.829]	Cover without Ejector Latch Slot
23.65 [.931]	Connector with Strain Relief

Figure 5

### 3.8. Termination



**CAUTION** A connector adapter, which is part of the tooling locator kit, must be placed in the connector when making a termination. It applies the insertion force to the connector mating face and not to the sides of the connector. If the adapter is not used, the termination force could cause fractures to the sides of the connector and damage the contact pins.

The cable must be placed in the slot between the cover and the housing and terminated with the tooling referenced in Section 5 to the specified termination height. If making an end-of-line application, the cable end must be even and within dimensional limits. In-line connectors must be positioned at your pre-determined location with connectors being as close as the termination tool will allow. See Figure 6.

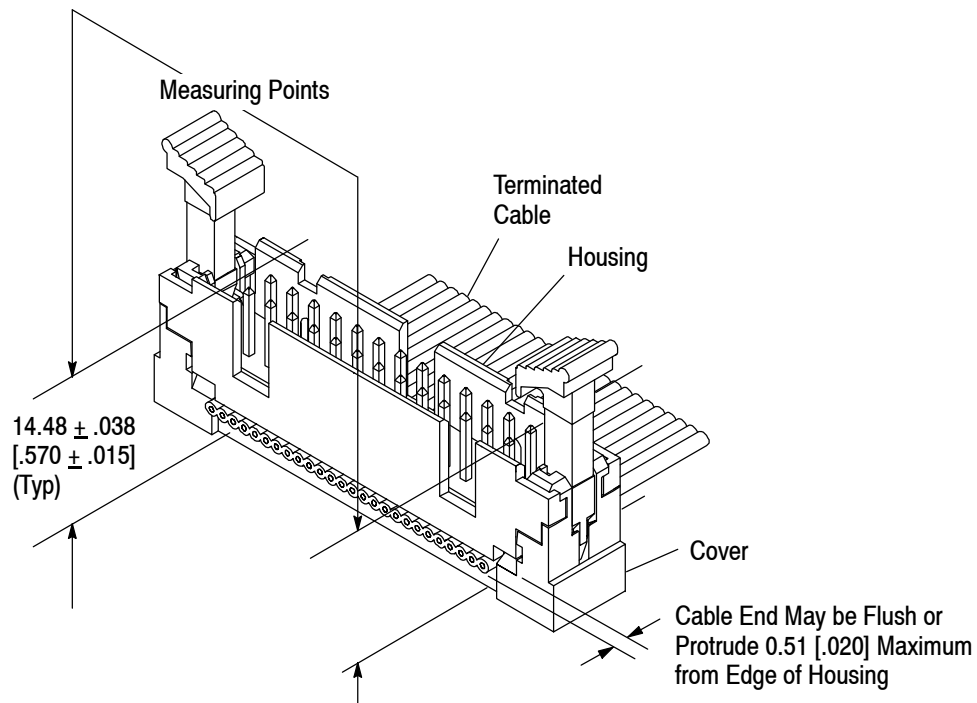

Figure 6

### 3.9. Strain Relief

A strain relief has been designed for covers without mounting ears. It must be installed after the cable is terminated and folded back 180° over the cover. The hooks of the strain relief are inserted into the strain relief slots until locked in place, then the cable can be dressed in any direction. See Figure 7.

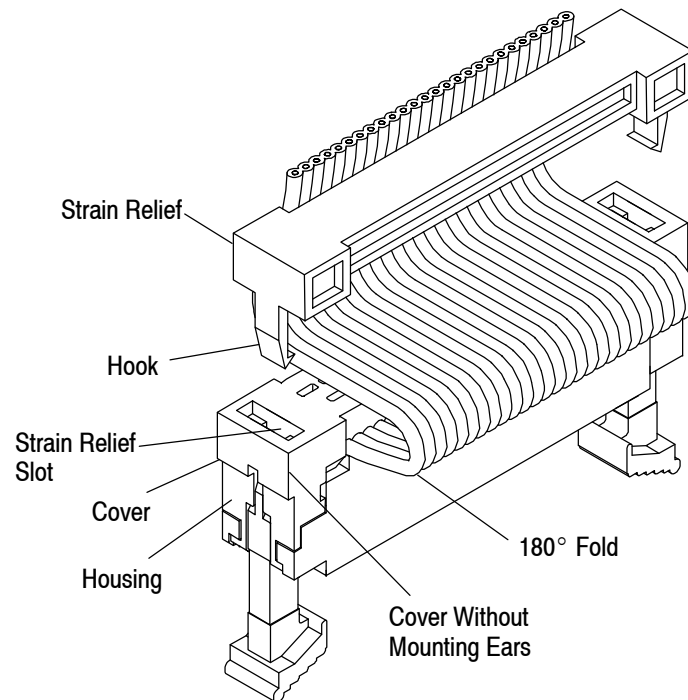

Figure 7

#### 4. QUALIFICATION

AMP-LATCH Universal I/O Pin Connectors are Listed by Underwriters Laboratories Inc. (UL) in File E28476, Certified to CSA International in File LR 16455, and tested by Verband Deutscher Elektrotechniker (VDE) in File No. 4751-9000-4009/A2D.

#### 5. TOOLING

The pin connectors are designed to be terminated to ribbon cable using either an manual or pneumatic frame unit equipped with the proper application tooling assembly. For part numbers and instruction sheet material numbers, see Figure 8.

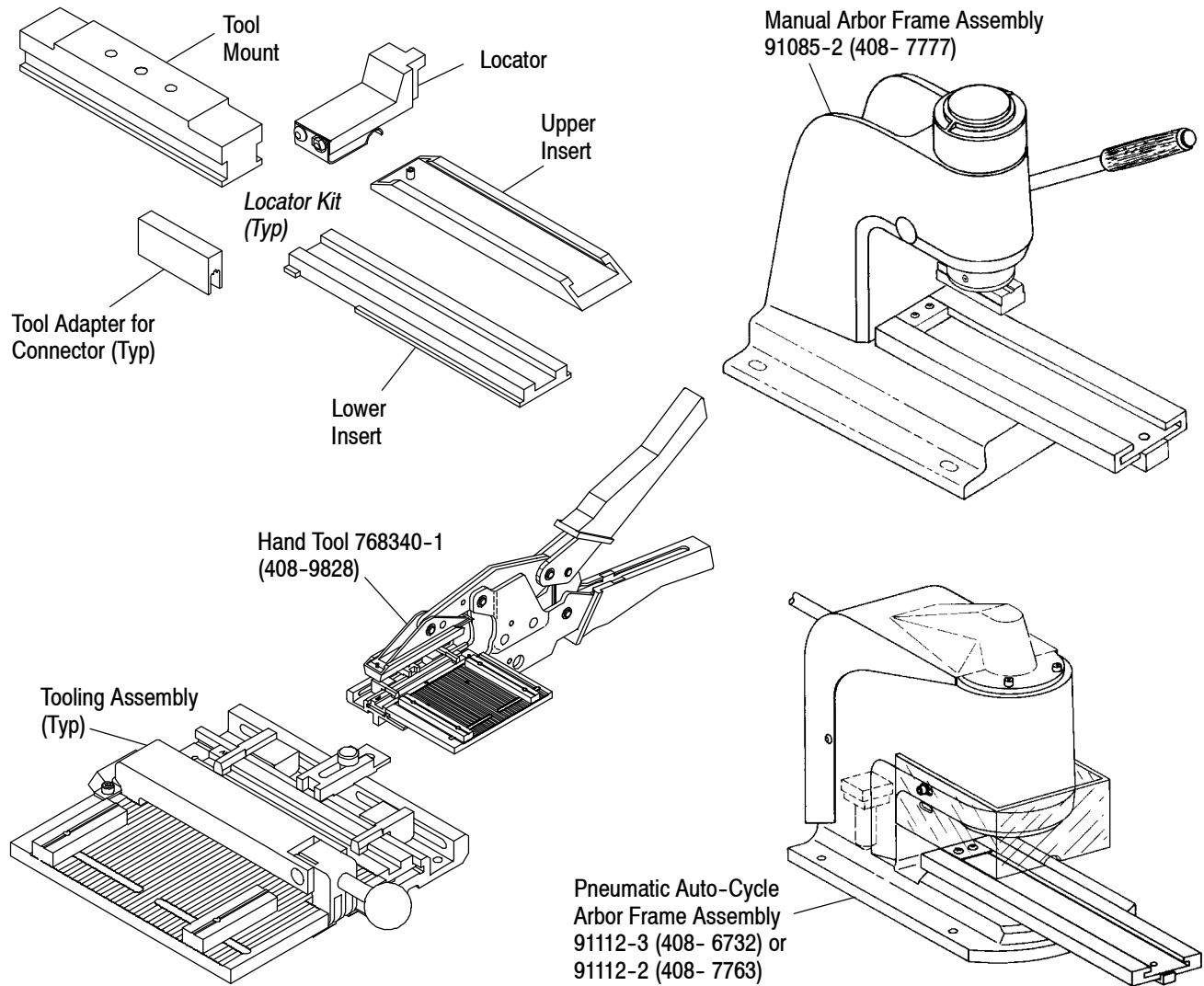

LOCATOR KIT (DOCUMENT)	TOOLING ASSEMBLY (DOCUMENT)	HAND TOOL KIT (DOCUMENT)	POWER UNIT (DOCUMENT)
768344-1 (408-9836)	768338-1 (408-9827)	768340-1 (408-9828)	91085-2 (408-7777) 91112-2 (408-7763) 91112-3 (408-6732)
---	189827-7 189827-8	---	189900-1 (409-5873)

Figure 8

**6. VISUAL AID**

Figure 9 shows a typical application of AMP-LATCH Universal I/O Pin Connectors. This illustration should be used by production personnel to ensure a correctly applied product. Applications which DO NOT appear correct should be inspected using the information in the preceding pages of this specification and in the instructional material shipped with the product or tooling.

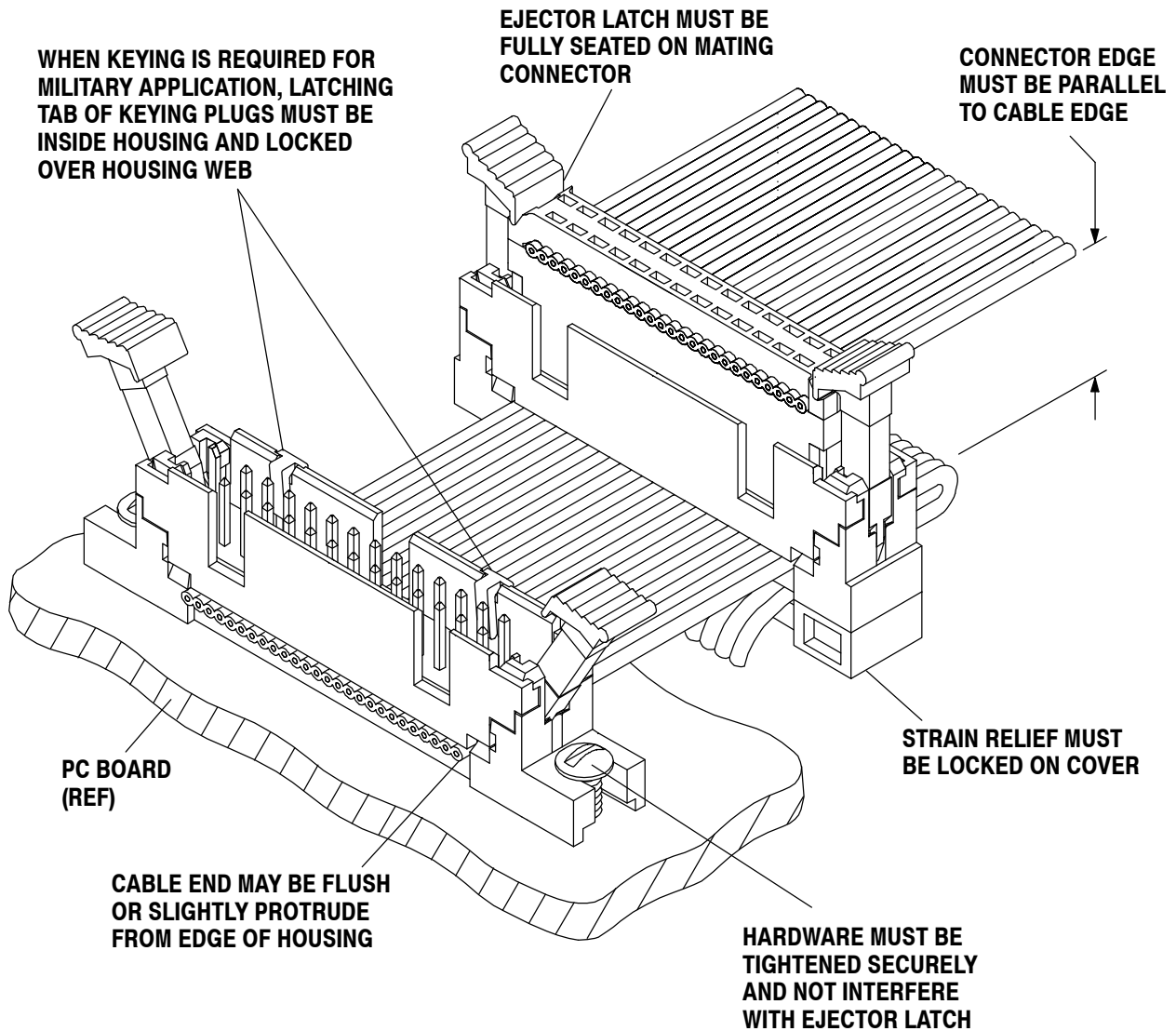

**FIGURE 9. VISUAL AID**