

KSZ8852HLE Evaluation Board User Guide

Revision 1.0 / August 20, 2014

Table of Contents

Introduction.....	3
1 Board Features	3
2 KSZ8852HLE-EVAL Evaluation Board Kit.....	3
3 Hardware Description.....	3
3.1 Device Configuration	5
3.1.1 Strap-in Configuration.....	5
3.1.2 EEPROM Configuration.....	5
3.2 Power Supplies.....	5
3.3 Port 3 Parallel Host Interface	6
3.4 GPIO pins.....	7
3.5 10/100 Ethernet PHY Ports	8
3.6 100BASE-FX Fiber Port Option	9
3.7 LED Indicators.....	9
3.8 List of Jumpers and Connectors	9
3.9 Board Layout.....	11
4 Using the KSZ8852HLE Evaluation Board	11
5 Reference Documents	12
6 Revision History	12

List of Figures

Figure 1 KSZ8852HLE Evaluation Board.....	4
Figure 2 Power Supply Section and Related Jumper Locations.....	6
Figure 3 GPIO Connectors and Strap-in Jumper Locations	8
Figure 4 Topside Layout of the Board.....	11

List of Tables

Table 1 Strap-In Configuration Jumpers	5
Table 2 Power Supply Related Jumpers	6
Table 3 Signal Descriptions on the Parallel (Host-Port) Connector J16.....	7
Table 4 GPIO Pin Selection for KSZ8852HLE	8
Table 5 LED Functions	9
Table 6 List of Jumpers and Connectors.....	10

Introduction

The KSZ8852HLE Evaluation Board provides a platform in which to test or explore the functionality of the KSZ8852HLE Ethernet switch.

The KSZ8852HLE is an integrated 3-port 10BASE-T / 100BASE-TX/FX managed Ethernet switch with two 10/100 PHY ports, and generic parallel interface connectivity to a host processor on port 3. The KSZ8852HLE includes all the functions of a 10/100BASE-T/TX/FX switch system that combines switch engine, frame buffers management, addresses look-up table, queue management, MIB counters, media access controllers (MAC) and PHY transceiver interfaces. It is fully compliant with the IEEE 802.3 standards (10BASE-T and 100BASE-TX).

This KSZ8852HLE Evaluation Board User Guide provides the information necessary to configure and set up the board to evaluate or test the KSZ8852HLE device in different environments.

1 Board Features

The KSZ8852HLE Evaluation Board encompasses the following features.

- Micrel's KSZ8852HLE Integrated 3-Port 10/100 Managed Ethernet Switch
- Two Ethernet LAN Interfaces with RJ-45 jacks and isolation magnetics (Ports 1 & 2)
- Auto MDI/MDI-X for automatic detection and correction for straight-through and crossover cables
- Generic 8/16 bit parallel Host processor interface (Port 3)
- Provisioning for line side and chip side over-voltage protection (optional)
- On-board 3.3V and 1.8V/2.5V regulators
- Configurable for VDDIO of 3.3V, 2.5V, or 1.8V operation
- Serial interface for EEPROM
- LED indicators for link status and activity of the RJ-45 ports
- 25 MHz crystal
- Jumpers for power up configuration of the device
- Jumpers for GPIO pins and I/O voltage selection
- Board operates from a single 5V DC supply
- Reset switch
- Various test points

2 KSZ8852HLE-EVAL Evaluation Board Kit

The KSZ8852HLE-EVAL kit includes the following:

- KSZ8852HLE Evaluation Board
- KSZ8852HLE Evaluation Board User's Guide (This document, available in the eval kit documentation at the Micrel website)
- KSZ8852HLE Evaluation Board Schematic (Available in the eval kit documentation at the Micrel website)

3 Hardware Description

The KSZ8852HLE Evaluation board is a small form-factor board (5.2" x 4.75") that can be configured by a host processor connected through the 16-bit generic parallel host interface. In addition to passing full-rate

Ethernet traffic, the external host processor can read and write the entire register set within the KSZ8852HLE device through this interface.

The board supports different types of host processors. Therefore a strap-in configuration mode is provided to set the parallel interface according to the type of processor used. Strap-in mode configuration occurs at power on time where the voltage level on certain pins is automatically sampled and used to configure various features in the device. This is accomplished with the on board jumper options.

Available configuration options are explained in detail in the following sections. Figure 1 is a picture of the KSZ8852HLE Evaluation board.

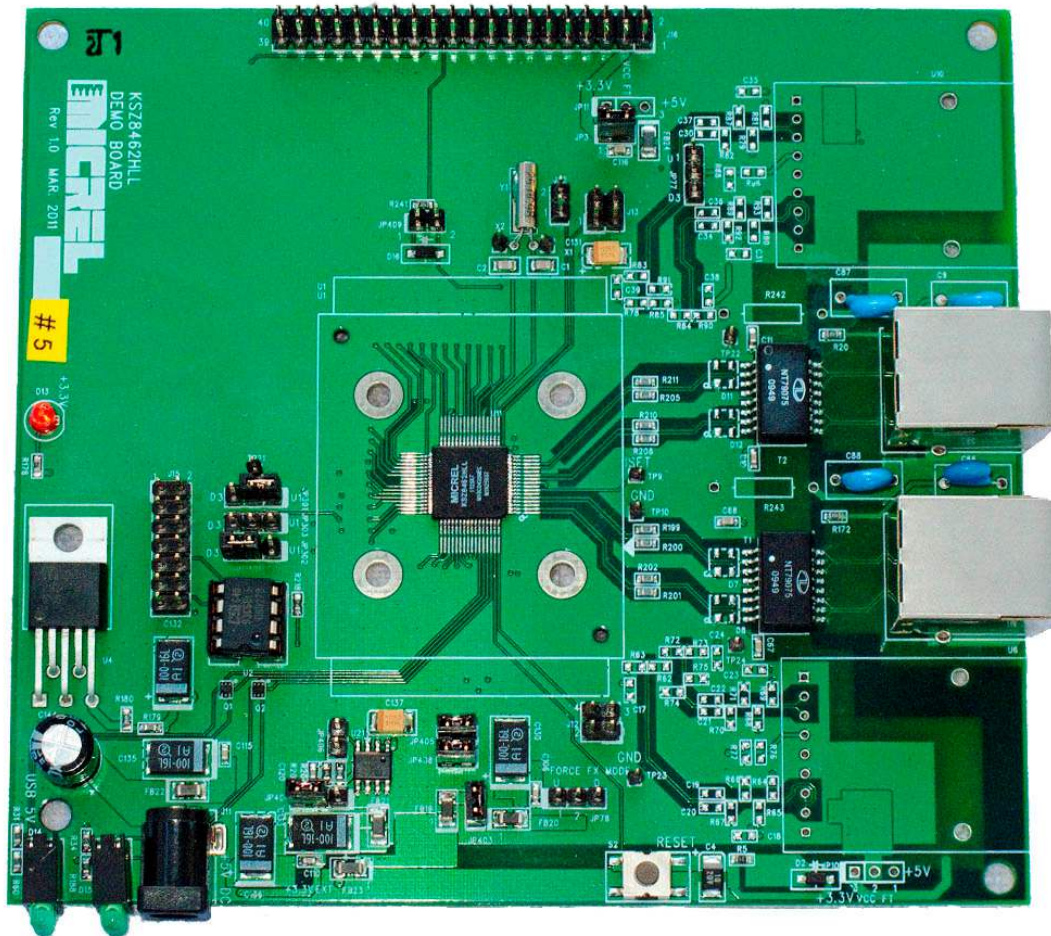

Figure 1 KSZ8852HLE Evaluation Board

3.1 Device Configuration

3.1.1 Strap-in Configuration

Strap-in configuration is used for setting up the parallel host interface and to indicate the presence of an EEPROM. This is accomplished by setting available configuration jumpers which are used at device power-up. Simply set the board's configuration jumpers to the desired settings and apply power to the board. The configuration can be changed while power is applied to the board by changing the jumper settings and pressing the convenient manual reset button for the new settings to take effect. Note that even if no external strap-in jumpers are set, internal pull-up and pull-down resistors will set the KSZ8852HLE to the default configuration.

The following table covers each jumper used for the strap-in option and describes its function.

JUMPER	FUNCTION	SETTING	DEFAULT
JP301	Parallel Bus Width select	Pins 1-2 closed: 16-bit Pins 2-3 closed: 8-bit	16-bit
JP302	Parallel Bus Endian-mode select	Pins 1-2 closed: Little Endian Pins 2-3 closed: Big Endian	Little Endian
JP303	EEPROM select	Pins 1-2 closed: EEPROM present Pins 2-3 closed: EEPROM not present	EEPROM not present

Table 1 Strap-In Configuration Jumpers

3.1.2 EEPROM Configuration

The KSZ8852HLE Evaluation Board has a serial EEPROM to enable loading the MAC address into the device at power-up time with a pre-programmed value. The strap-in option should be set to enable the EEPROM presence, as indicated on the above table. If enabled, the first seven words of the Serial EEPROM will be read. Registers 0x010 – 0x015 will be loaded with words 0x01 – 0x03 from the EEPROM.

In addition, the remainder of EEPROM space (0x07 – 0x3F) can be written or read and used as needed by the host processor.

Supported EEPROM: 93C46

3.2 Power Supplies

The board requires a single 5V DC supply, which can be provided through a barrel power-supply jack (J11) or through the parallel host port. The current requirement is 200mA.

The pin diameter of jack J11 is 2.5mm on early boards, and is 2.1mm on newer boards. 2.5mm plugs are recommended because they are generally compatible with both jack sizes. A 2.1mm plug, however, cannot be used with the 2.5mm jack.

JP3 must be in place if the board is powered through the parallel port. There is a 3.3V regulator on the board supplying power for the KSZ8852HLE and other components. A separate on-board voltage regulator is provided for the optional 2.5V and 1.8V supplies for KSZ8852HLE's I/O interface (VDD_IO).

JP404 and JP406 are used for VDD_IO selection. JP403 and JP405 must be in place and other options properly selected before powering up the board.

JUMPER	FUNCTION	SETTING		
JP3	Enable +5V supply from host-port connector J16	Closed: enabled Open: disabled, use external power supply through J11		
JP403	+3.3V supply for KSZ8852 analog circuits	Must be closed		
JP405	+1.2V supply for KSZ8852 analog circuits	Must be closed		
JP408	+1.2V supply for KSZ8852 digital circuits	Must be closed		
	VDD_IO selection	3.3V	2.5V	1.8V
JP404		Pins 2-3 closed	Pins 1-2 closed	Pins 1-2 closed
JP406		X	open	Closed

Table 2 Power Supply Related Jumpers

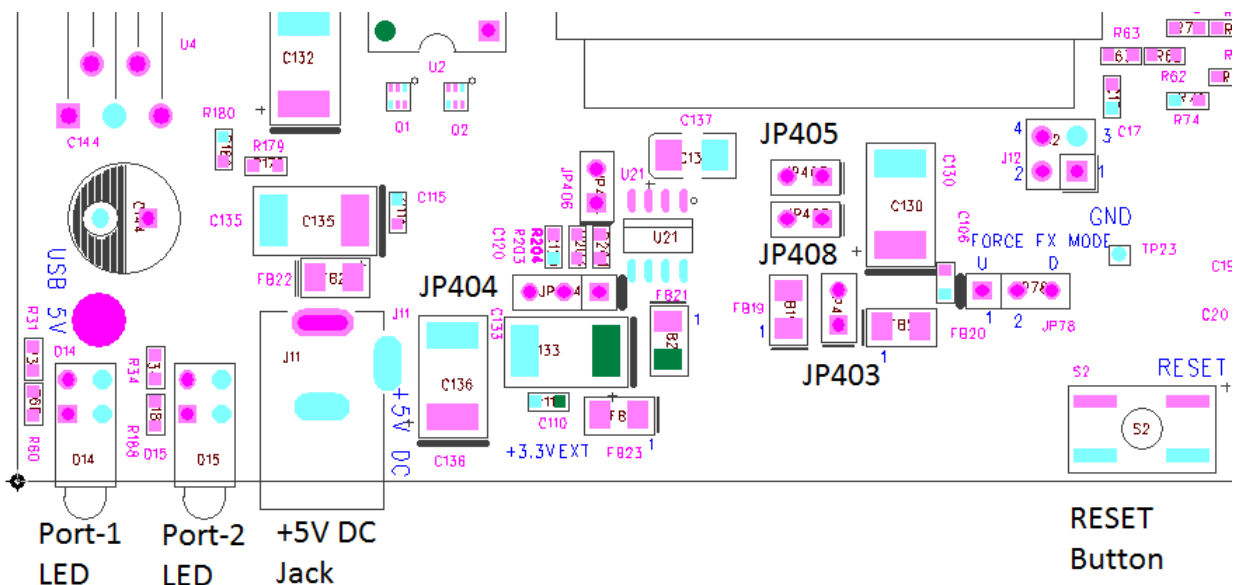

Figure 2 Power Supply Section and Related Jumper Locations

3.3 Port 3 Parallel Host Interface

The board features a 40-pin connector (J16) for interfacing the Bus Interface Unit (BIU) on the KSZ8852HLE to an external host processor. The BIU is a generic parallel host interface providing access to the MAC of Port 3.

The 40-pin connector is a standard dual-row straight pin header. To access the internal registers, MIB counters, etc., a host processor board such as the Micrel KSZ9692MII-PTP-EV board has to be connected to the parallel interface. Strap-in configurations determine the mode of host interface operation at power-up.

The voltage level on all interface pins (VDD_IO) can be set to 1.8V, 2.5V or 3.3V of operation, enabling a direct connection to different type of host processors.

Signal	Pin No.	Type	Function
SD[15:0]	5-20	I/O	<p>Shared Data Bus In 16-bit mode: SD[15:0] -> D[15:0] data access when CMD = "0". SD[10:2] -> A[10:2] address access and SD[15:12] -> BE[3:0] byte enable access when CMD = "1" (SD[1:0] and SD[11] are not used).</p> <p>In 8-bit mode: SD[7:0] -> D[7:0] data access when CMD = "0". SD[7:0] -> A[7:0] 1st address access and SD[2:0] -> A[10:8] 2nd address access when CMD = "1" (SD[7:3] are not used during 2nd address access).</p>
CMD	28	Input	<p>Command Type This command input determines the SD[15:0] shared data bus access cycle information. 0: Data access 1: Command access for address and byte enable</p>
CSN	23	Input	<p>Chip Select Enable Chip Enable is an active low signal used to enable the shared data bus access.</p>
INTRN	31	Output	<p>Interrupt This low active signal asserted low when an interrupt is being requested.</p>
RDN	36	Input	<p>Asynchronous Read This low active signal is asserted to low during a read cycle. A 4.7K pull-up resistor is recommended on this signal.</p>
WRN	35	Input	<p>Asynchronous Write This low active signal is asserted low during a write cycle.</p>
PME/ EEPROM	27	Output/ Input	<p>Power Management Event This output signal indicates that a Wake On LAN event has been detected. The KSZ8852HLE is requesting the system to wake up from low power mode. Its assertion polarity is programmable with the default polarity to be active low.</p> <p>EEPROM select Configuration Mode During Power-on/Reset time this pin is an input and the strap-in value is read by KSZ8852HLE to determine the presence of an EEPROM. (see description of JP303 in Table 1)</p>
RSTN	24	Input	<p>Reset This is the Hardware reset pin. It is active Low. This reset input is required to be low for a minimum of 10 ms after supply voltages VDD_IO and 3.3V are stable.</p>
+5V	1, 3		<p>Power supply Connection to +5V supply of the Host processor board.</p>
GND	2, 4, 21, 22, 25, 26, 29, 33, 34, 37-40		<p>Ground</p>
N.C.	30, 32		

Table 3 Signal Descriptions on the Parallel (Host-Port) Connector J16

3.4 GPIO pins

KSZ8852HLE chip has up to 7 General Purpose I/O (GPIO) pins which are available on the evaluation

board at connector J15. Three GPIO pins of the KSZ8852HLE device are shared with EEPROM signals and are user programmable. By default the EEPROM signals are enabled, therefore initially only 4 GPIO pins are available. If more than 4 GPIO pins are required, the user needs to program IOMUXSEL register (0x0D6) as follows:

IOMUXSEL register (0x0D6)	Description	Setting
Bit 5	Selection of EESK or GPIO3 for Pin 53	1 = This pin is used for EESK (default) 0 = This pin is used for GPIO3
Bit 2	Selection of EEDIO or GPIO4 for Pin 54	1 = This pin is used for EEDIO (default) 0 = This pin is used for GPIO4
Bit 1	Selection of EECS or GPIO5 for Pin 55	1 = This pin is used for EECS (default) 0 = This pin is used for GPIO5

Table 4 GPIO Pin Selection for KSZ8852HLE

GPIO signals are on the odd numbered pins of connector J15. All even numbered pins are GND connections.

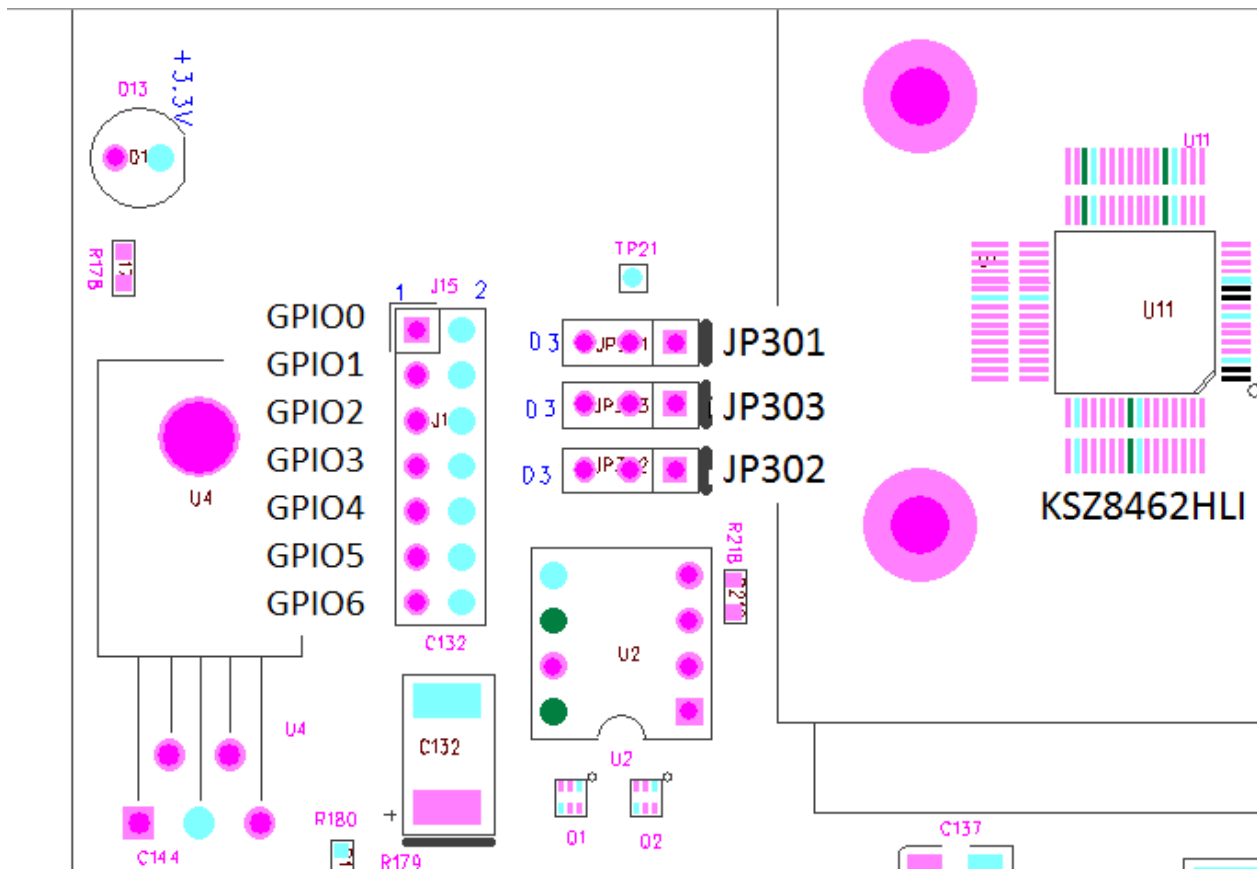

Figure 3 GPIO Connectors and Strap-in Jumper Locations

3.5 10/100 Ethernet PHY Ports

There are two 10/100 Ethernet PHY ports on the KSZ8852HLE evaluation board. The ports can be connected to an Ethernet traffic generator or analyzer via standard RJ-45 connectors using CAT-5 (or better) UTP cables. Both ports support auto MDI/MDI-X, eliminating the need for cross-over cables.

Transformers are utilized for proper interfacing to an Ethernet network. In addition, optional over-voltage protection devices D5 thru D12 may be installed to protect the KSZ8852HLE in the event of an over-voltage condition.

The FXSD1 and FXSD2 pins should be pulled low by installing jumpers on pins 3 & 4 of J12 and J13.

3.6 100BASE-FX Fiber Port Option

The board supports optional 100BASE-FX fiber modules, but this feature is not available on the KSZ8852HLE. For applications that require fiber on one or both 100 Mbps ports, use the KSZ8462HL.

3.7 LED Indicators

The evaluation board provides two LEDs (PxLED1, PxLED0) for each PHY port. The LED indicators are programmable to four different states. LED mode is selected through bits [9:8] of the SGCR7 register (0x00E-0x00F).

The LED mode definitions are specified in Table 7. See Figure 2 for the LEDs' orientation on the KSZ8852HLE evaluation board in the power supply section.

SGCR7 Control Register (0x00E-0x00F) Bits[9:8]			
00 (default)	01	10	11
PxLED1 = Speed	PxLED1 = Active	PxLED1 = Duplex	PxLED1 = Duplex
PxLED0 = Link/Active	PxLED0 = Link	PxLED0 = Link/Active	PxLED0 = Link

Table 5 LED Functions

The KSZ8852HLE evaluation board also has a power LED (D3) for the 3.3V power supply. When D3 is illuminated, the board's 3.3V power supply is "on".

The activity LED indicators for Port-1 and Port-2 are powered by 3.3V, regardless of the VDD_IO selected for the device.

3.8 List of Jumpers and Connectors

Jumper	Description	Setting
JP2	PWRDN Chip Power-down	Place Jumper for full chip power-down
JP3	Enable +5V supply from host-port connector	Closed: enabled Open: disabled
JP10, 11	Power selection for the Fiber module	Leave open when no Fiber Module present
JP77, 78	FXSD1, FXSD2 Fiber signal detect input for Port 1 and Port 2 (not used)	

Jumper	Description	Setting
JP301-303	Strapping options	See Table 1
JP403-408	Power-supply strapping options	See Table 2
JP409	Enable bi-directional Reset signal	Closed: enable Reset signal on both directions Open: Local reset signal does not affect the host processor board.
J1, J2	RJ45 connectors for Port-1 and Port-2	
J11	+5V DC Power Jack	
J12, J13	FXSD pin connections	Pins 1-2 closed: connect to SD signal from fiber module Pins 3-4 closed: ground the FXSD pins, for copper mode
J15	GPIO Header	
J16	Parallel Host-port interface (Port-3)	

Table 6 List of Jumpers and Connectors

3.9 Board Layout

The layout of the board is shown in Figure 3. The key areas are indicated.

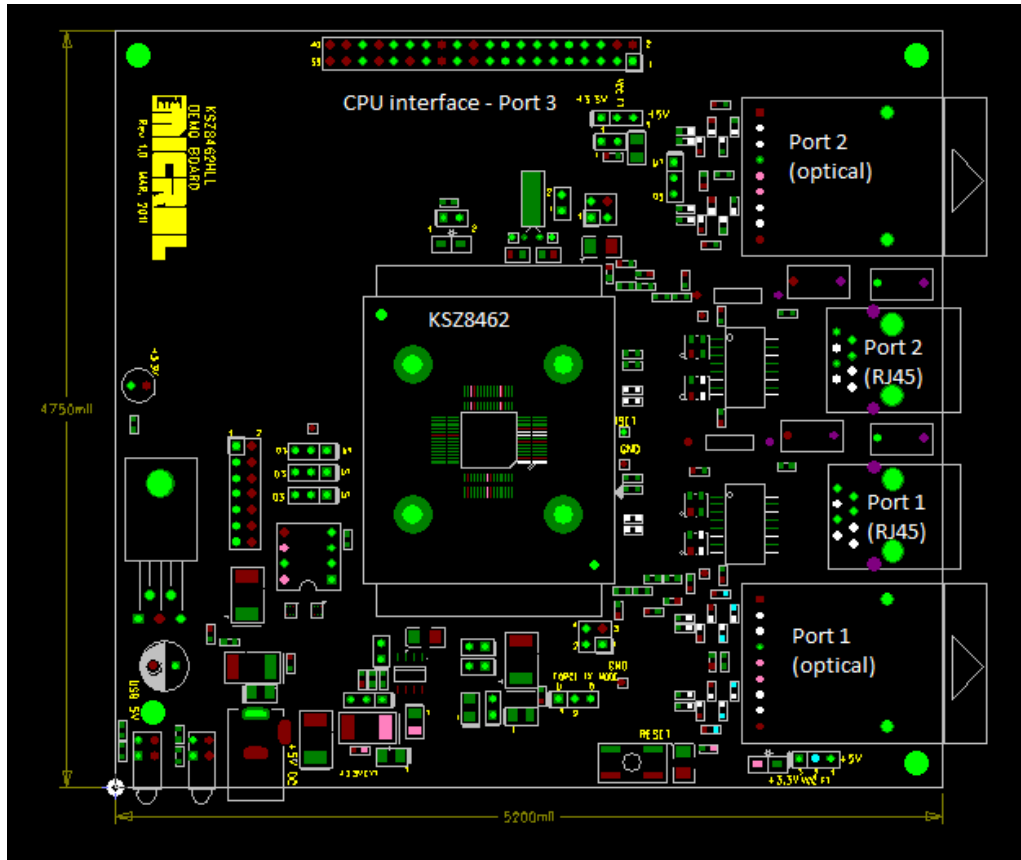

Figure 4 Topside Layout of the Board

The KSZ8852HLE Evaluation board interfaces directly with the KSZ9692PB SOC board (KSZ9692-MII-PTP-EV), providing a complete evaluation platform. In this setup, Port3 of the KSZ8852HLE is connected to the SOC board through its parallel host interface. For more details on this configuration, refer to the KSZ8462HL Evaluation Kit User Guide.

4 Using the KSZ8852HLE Evaluation Board

The Evaluation Board is intended to provide a platform that enables designers to investigate and evaluate the capabilities of the KSZ8852HLE device. It is not intended to be a complete development system to be used for an entire product design effort.

5 Reference Documents

KSZ8852HLE Datasheet
 KSZ8852HLE Evaluation Board Schematic
 KSZ8852HLE Evaluation Board Gerber files
 IEEE802.3 Specification
 KSZ8462HL Evaluation Kit User Guide

6 Revision History

Revision	Date	Summary of Changes
1.0	8/20/2014	First release

© Micrel, Inc. 2014
 All rights reserved

Micrel is a registered trademark of Micrel and its subsidiaries in the United States and certain other countries. All other trademarks are the property of their respective owners.

The information furnished by Micrel in this datasheet is believed to be accurate and reliable. However, no responsibility is assumed by Micrel for its use. Micrel reserves the right to change circuitry and specifications at any time without notification to the customer. Micrel Products are not designed or authorized for use as components in life support appliances, devices or systems where malfunction of a product can reasonably be expected to result in personal injury. Life support devices or systems are devices or systems that (a) are intended for surgical implant into the body or (b) support or sustain life, and whose failure to perform can be reasonably expected to result in a significant injury to the user. A Purchaser's use or sale of Micrel Products for use in life support appliances, devices or systems is at Purchaser's own risk and Purchaser agrees to fully indemnify Micrel for any damages resulting from such use or sale.
