

**Features and Benefits**

- Four grades of magnetic materials
- Cost effective design
- High resistance to demagnetization
- Operation from -40°C to 125°C
- Tough environmental endurance
- Very resistant to chipping
- Wide range of pole counts

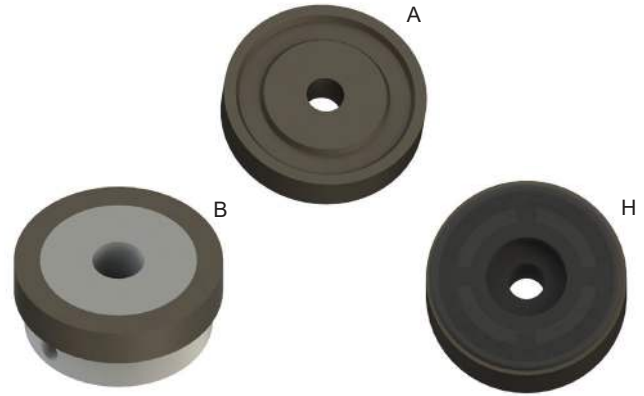

Molded Target Magnet

**Physical Properties of Magnetic Material**

Table 1.1

Characteristic	Value	Units
Tensile Strength	6500	PSI
Flexural Strength	9750	PSI
Flexural Modulus	1.3 X 10 <sup>6</sup>	PSI
Continuous Service Temperature	100	°C

**Magnetic Properties**

Table 1.2

Characteristic	Magnalox 300	Neobond 12M	Neobond 30M	Neobond 32P	Units
Remanence (B <sub>r</sub> )	1370	2500	4000	4300	Gauss
Coercive Force (H <sub>c</sub> )	1180	2400	3250	2500	MGOe
Energy Product (BH <sub>MAX</sub> )	0.40	1.3	3.1	3.2	Oersted
Intrinsic Coercive Force (H <sub>ci</sub> )	2300	7500	7000	6900	Oersted
Reversible Temperature Coefficient	-0.2	-0.35	-0.4	-0.4	/°C
Specific Gravity	3.5	4.0	4.7	4.45	---

**Pole Counts**

Alternating north and south magnetic poles are symmetrically located on the outer diameter for radial sensing.

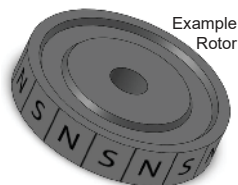

Example Rotor

**Note:** (N)orth/(S)outh markings are for illustration and do not appear on the actual product.

Available Pole Counts	2, 4, 6, 8, 10, 12, 14, 16, 18, 20, 24, 28, 30, 32, 34, 36, 38, 40, 44, 50, 52, 60
-----------------------	--

**Target Rotor Physical Outline - Molded (Mounting Style A)**

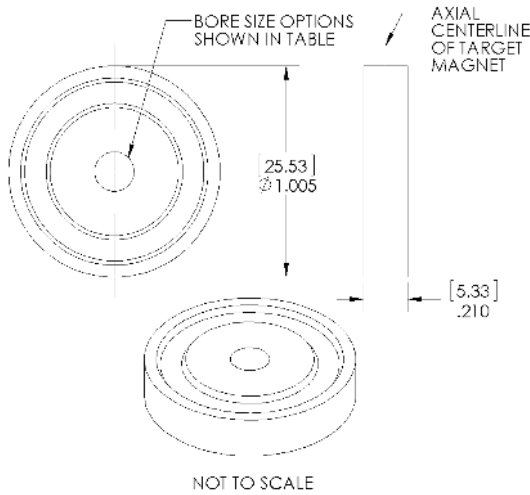

**Table 2.1**

Bore Size (.inch)	Motor Shaft OD Size (nominal)	NEMA Guide Shaft Tolerance	Magnet Bore MIN. (inch)	Magnet Bore MAX. (inch)
079	2 mm (.0787")	+0.0000"/-0.0005"	.0777	.0807
118	3 mm (.1181")		.1171	.1201
125	1/8 in (.1250")		.1240	.1270
156	5/32 in (.1563")		.1553	.1583
157	4 mm (.1575")		.1565	.1595
188	3/16 in (.1875")		.1865	.1895
197	5 mm (.1969")		.1959	.1989
236	6 mm (.2364")		.2354	.2384
250	1/4 in (.2500")		.2490	.2520
276	7 mm (.2758")		.2747	.2777
313	5/16 in (.3125")		.3115	.3145
315	8 mm (.3150")		.3140	.3170
375	3/8 in (.3750")		.3740	.3770
394	10 mm (.3940")		.3930	.3960
473	12 mm (.4728")		.4718	.4748
500	1/2 in (.5000")		.4990	.5020

Other bore sizes available upon request.  
Contact [sales@phoenixamerica.com](mailto:sales@phoenixamerica.com).

**Target Rotor Mounting Guidelines - Molded (Mounting Style A) For Slip Fit Application**

- Proper alignment of the target rotor is critical for optimal performance.
- A machined step on the motor shaft provides a quick and repeatable method for positioning the target rotor. Spacers or other fixturing should be used to properly position the rotor if no mechanical locating features are on the shaft.
- Various adhesives can be used to bond the target rotor to the motor shaft. Shaft alloys, operating environment, and shaft speed and acceleration should be taken into consideration when selecting an appropriate bonding agent. Loctite threadlockers and retaining compounds have proved effective in bonding the target rotor to the motor shaft. Loctite 263 and 2760 threadlockers and Loctite 638 and 680 retaining compounds are good candidates. These materials have been effective in past experience; testing under actual operating conditions should be used to qualify any bonding material.
- For best results, the motor shaft should be clean and free of any oils, lubricants, or solvents.
- Apply adhesive around the leading edge of the shaft and inside the hole in the rotor. Use a rotating motion when assembling the magnet to the shaft to insure good adhesive coverage.
- The use of primers and activators can be used to improve bond strength and cure rate.
- For non-critical applications or for fast bonding for evaluation, a cyanoacrylate adhesive (super glue) can be used. Loctite 401 and 410 have proven effective for quick bonding applications.

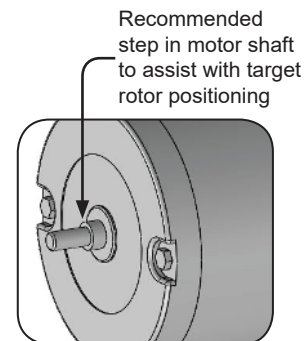
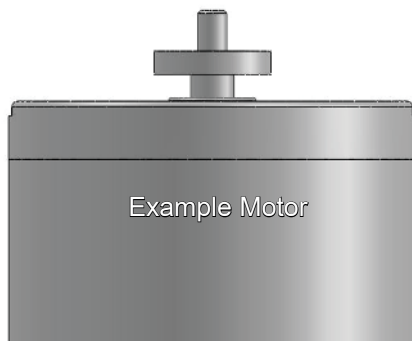

**Target Rotor Physical Outline - Aluminum Hub (Mounting Style B)**

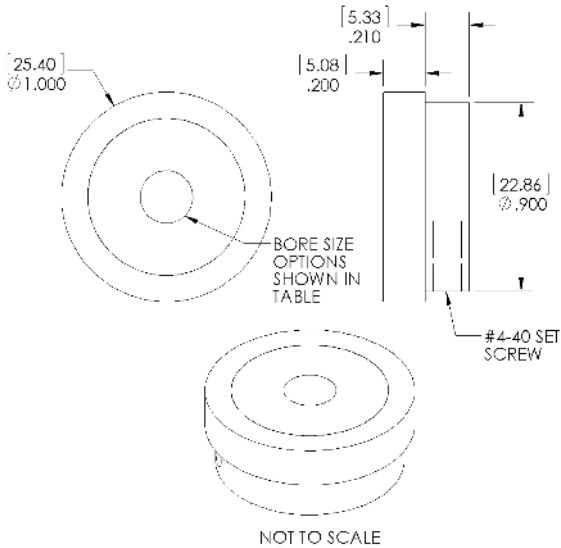

**Table 3.1**

Bore Size (.inch)	Motor Shaft OD Size (nominal)	NEMA Guide Shaft Tolerance	Magnet Bore MIN. (inch)	Magnet Bore MAX. (inch)
079	2 mm (.0787")	+0.0000"/-0.0005"	.0794	.0803
118	3 mm (.1181")		.1188	.1197
125	1/8 in (.1250")		.1257	.1266
156	5/32 in (.1563")		.1570	.1579
157	4 mm (.1575")		.1582	.1591
188	3/16 in (.1875")		.1882	.1891
197	5 mm (.1969")		.1976	.1985
236	6 mm (.2364")		.2371	.2380
250	1/4 in (.2500")		.2507	.2516
276	7 mm (.2758")		.2767	.2778
313	5/16 in (.3125")		.3134	.3145
315	8 mm (.3150")		.3159	.3170
375	3/8 in (.3750")		.3759	.3770
394	10 mm (.3940")		.3949	.3960
473	12 mm (.4728")		.4737	.4748
500	1/2 in (.5000")		.5009	.5020

Other bore sizes available upon request.  
Contact [sales@phoenixamerica.com](mailto:sales@phoenixamerica.com).

**Target Rotor Mounting Guidelines - Aluminum Hub (Mounting Style B)**

- Proper alignment of the target rotor is critical for optimal performance.
- A machined step on the motor shaft provides a quick and repeatable method for positioning the target rotor. Spacers or other fixturing should be used to properly position the rotor if no mechanical locating features are on the shaft.
- While the hub is held in the proper position, use a .50 inch hex wrench to tighten #4-40 set screw.
- For permanent applications, a threadlocker or retaining compound is advised in conjunction with the set screw.

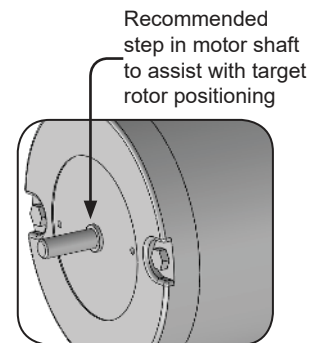

**Target Rotor Physical Outline - Engineered Polymer Hub (Mounting Style H)**

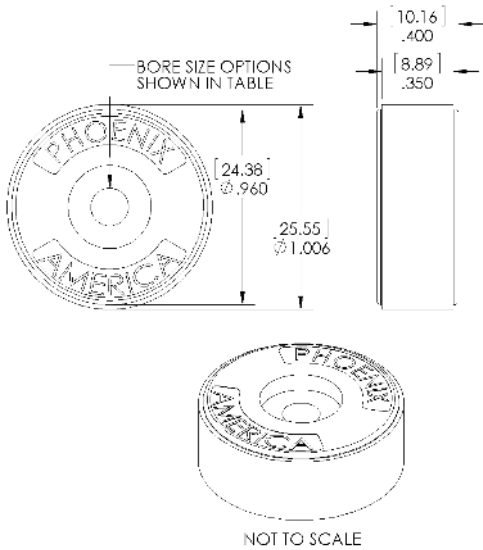

**Table 4.1**

Bore Size (.inch)	Motor Shaft OD Size (nominal)	NEMA Guide Shaft Tolerance	Magnet Bore MIN. (inch)	Magnet Bore MAX. (inch)
079	2 mm (.0787")	+0.0000"/-0.0005"	.0727	.0757
118	3 mm (.1181")		.1121	.1151
125	1/8 in (.1250")		.1190	.1220
156	5/32 in (.1563")		.1503	.1533
157	4 mm (.1575")		.1515	.1545
188	3/16 in (.1875")		.1815	.1845
197	5 mm (.1969")		.1909	.1939
236	6 mm (.2364")		.2304	.2334
250	1/4 in (.2500")		.2440	.2470
276	7 mm (.2758")		.2698	.2728
313	5/16 in (.3125")		.3065	.3095
315	8 mm (.3150")		.3090	.3120
375	3/8 in (.3750")		.3690	.3720
394	10 mm (.3940")		.3880	.3910
473	12 mm (.4728")		.4668	.4698
500	1/2 in (.5000")		.4940	.4970

Other bore sizes available upon request.  
Contact [sales@phoenixamerica.com](mailto:sales@phoenixamerica.com).

**Target Rotor Mounting Guidelines - Engineered Polymer Hub (Mounting Style H) For Press Fit Application**

- Proper alignment of the target rotor is critical for optimal performance.
- A machined step on the motor shaft provides a quick and repeatable method for positioning the target rotor. Spacers or other fixturing should be used if no mechanical locating features are on the shaft.
- A chamfered lead in on the shaft will aid in aligning the rotor.
- Prior to insertion, the motor shaft should be clean and free of any oils, lubricants, or solvents.
- Proper fixtures and support must be used to ensure the magnet is pressed on straight and aligned with the motor shaft.
- Opposite end of motor shaft should be supported to avoid undue stress on motor bearings during the pressing operation.
- In applications with high torque or environmental extremes, a retaining compound can be used to enhance the strength of the press fit.

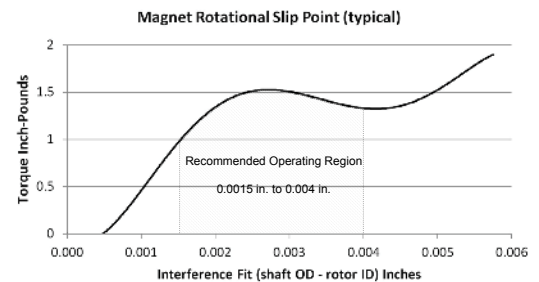
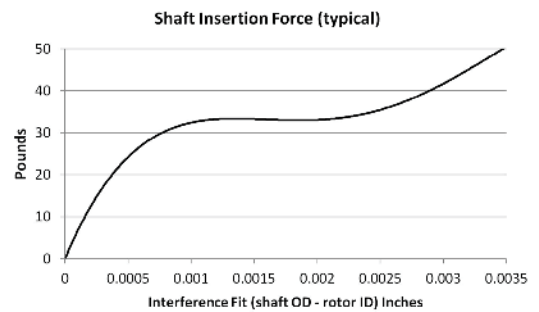

Part Number Description

Series	Design Style	Bore Size	Magnet Material	Pole Count
G16	<b>A Molded</b>	<b>079</b> 2 mm	<b>25</b> <i>Magnalox 300</i>	<b>R02</b> 2 Poles
	<b>B Aluminum Hub</b>	<b>118</b> 3 mm	<b>50</b> <i>Neobond 12M</i>	<b>R04</b> 4 Poles
	<b>H Engineered Polymer Hub</b>	<b>125</b> 1/8 in	<b>75</b> <i>Neobond 30M</i>	<b>R06</b> 6 Poles
		<b>156</b> 5/32 in	<b>85</b> <i>Neobond 32P</i>	<b>R08</b> 8 Poles
		<b>157</b> 4 mm		<b>R10</b> 10 Poles
		<b>188</b> 3/16 in <i>(default)</i>		<b>R12</b> 12 Poles
		<b>197</b> 5 mm		<b>R14</b> 14 Poles
		<b>236</b> 6 mm		<b>R16</b> 16 Poles
		<b>250</b> 1/4 in		<b>R18</b> 18 Poles
		<b>276</b> 7 mm		<b>R20</b> 20 Poles
		<b>313</b> 5/16 in		<b>R22</b> 22 Poles
		<b>315</b> 8 mm		<b>R24</b> 24 Poles
		<b>375</b> 3/8 in		<b>R28</b> 28 Poles
		<b>394</b> 10 mm		<b>R30</b> 30 Poles
		<b>473</b> 12 mm		<b>R32</b> 32 Poles
		<b>500</b> 1/2 in		<b>R34</b> 34 Poles
				<b>R36</b> 36 Poles
				<b>R38</b> 38 Poles
				<b>R40</b> 40 Poles
				<b>R44</b> 44 Poles
				<b>R50</b> 50 Poles
				<b>R52</b> 52 Poles
				<b>R60</b> 60 Poles

Example: G16-A-188-25-R08