

PART NUMBER  
HM2C09D\_CO21L9LF

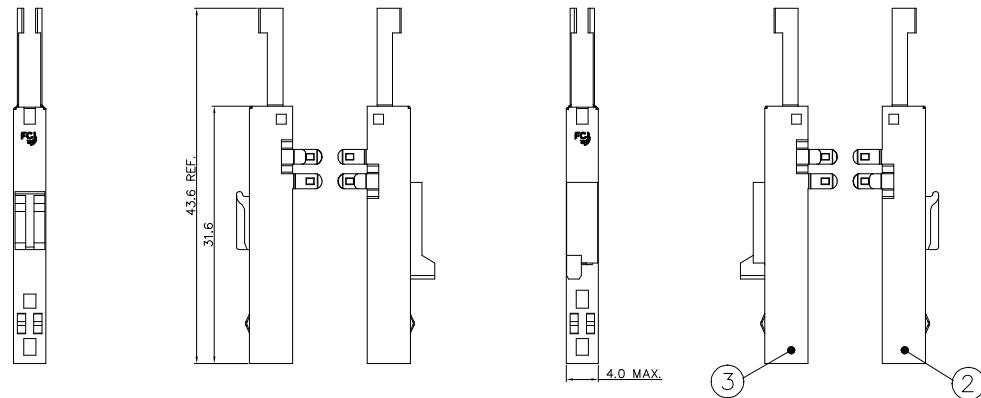
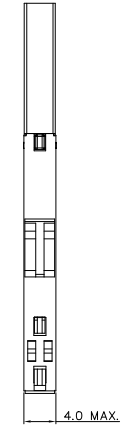
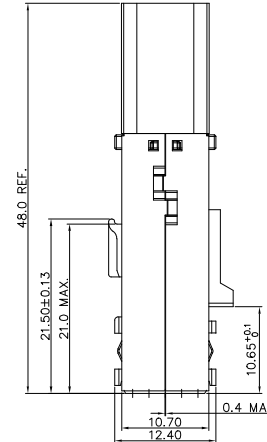
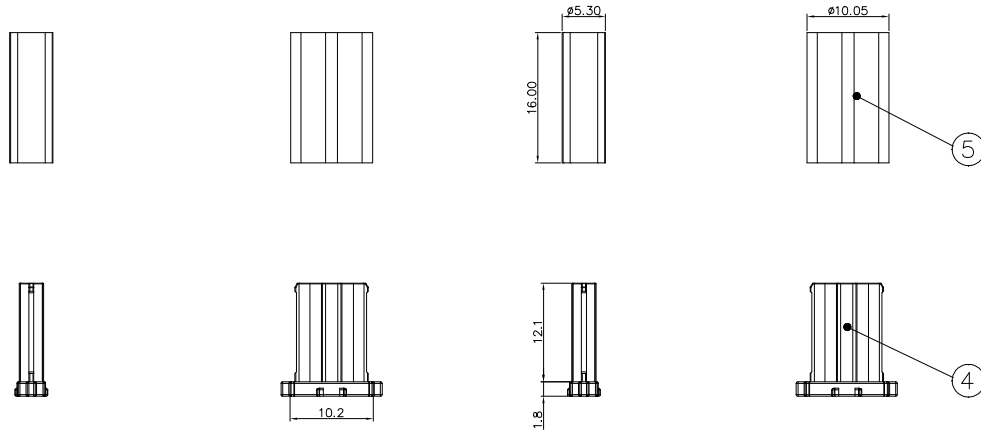

PERFORMANCE CHARACTERISTICS:

- VOLTAGE RATING : 250 VAC.
- CURRENT RATING : 1.0 A AT 70°C.
- INSULATION RESISTANCE : 10<sup>11</sup> MΩ MIN. AFTER TEST.
- DIELECTRIC WITHSTANDING VOLTAGE : 500 V.
- CONTACT RESISTANCE : 20 mΩ MAX. AFTER TEST.
- OPERATING T° : -55°C TO +125°C.
- INSERTION FORCE : 0.75 N MAX. PER CONTACT.
- WITHDRAWAL FORCE : 0.15 N MIN. PER CONTACT.

THE APPLICATION SPECIFICATION NO. : GS-20-096

WIRE CHARACTERISTICS:  
INSULATION DIAMETER 1,20 MM MAX.

CABLE CHARACTERISTICS:  
SEE DRAWING BS,A ,202664,001

PART NUMBERS :  
HM2C09D0C021L9LF : CONNECTOR FOR WIRE SIZE AWG28,AWG30  
HM2C09D2C021L9LF : CONNECTOR FOR WIRE SIZE AWG26

MATERIALS:

- TERMINAL BLOCK : GLASS REINFORCED THERMOPLASTIC UL94-V0.
- CONTACTS : PHOSPHOR BRONZE.
- PERFORMANCE : TELCORDIA CO.
- SHIELDING COVER : STAINLESS STEEL
- INNER FERRULE : Sn PLATED E-Cu
- OUTER FERRULE : Sn PLATED E-Cu

5	1	2X5 POS. SHIELDED HM2 OUTER FERRULE
4	1	2X5 POS. SHIELDED HM2 INNER FERRULE
3	1	2X5 POS. SHIELDED HM2 COVER PART (POLARISATION SIDE)
2	1	2X5 POS. SHIELDED HM2 COVER PART (LOCKING SIDE)
1	1	2X5 POS. STACKABLE CABLE CONN. WITHOUT COVER
Item	Qty	Description

Notes:

1. WHEN PART NUMBER WITH "LF" SUFFIX, THEN THE LF CONTACTS MUST BE USED .
2. THIS PRODUCT WITH "LF" SUFFIX MEETS EUROPEAN UNION DIRECTIVES AND OTHER COUNTRY REGULATIONS AS DESCRIBED IN GS-22-008 .

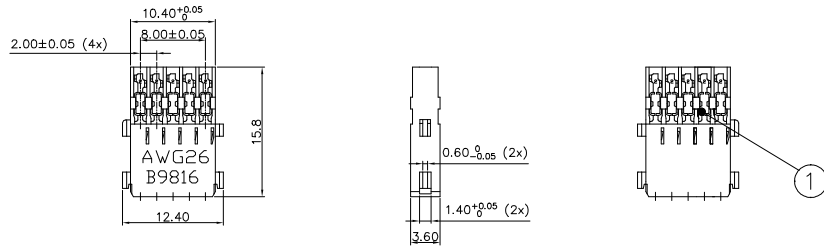

mat'l. code		surface tolerance ISO 1302 <input checked="" type="checkbox"/> ISO 406/ISO 1101		projection 		product family Millipacs	
ltr ecn no dr date		tolerances unless otherwise specified		mm 		title 2X5 POS. HM2 STACKABLE CABLE CONN WITH COVER	
A	-	KN	21/01/2003	angle	.X±.0.50	scale 1:1	
B	DG05-0244	CLU	26/07/2005	0°	.XX±.20		
C	DG08-0117	Nickor	18/03/2008	0°±2°	.XXX±.10		
D	ELX-N-004867	A.ZH	03/08/2011	dr	A.Jonssens 21/12/1998	dwg no sheet 1 of 1 size	
E	ELX-N-33153	DAISY	10/04/2019	eng	G.Droesbeke 25/06/1999	BSE202594001 A4	
				chr	G.Droesbeke 25/06/1999	type Product Customer Drawing	
				app	G.Droesbeke 25/06/1999		
sheet index	revision sheet	E	1				