

THIS DRAWING IS UNPUBLISHED. RELEASED FOR PUBLICATION
 © COPYRIGHT - By - ALL RIGHTS RESERVED.

REVISIONS					
P	LTR	DESCRIPTION	DATE	DWN	APVD
	F	REV PER ECO-19-015425	100CT2019	RS	DH

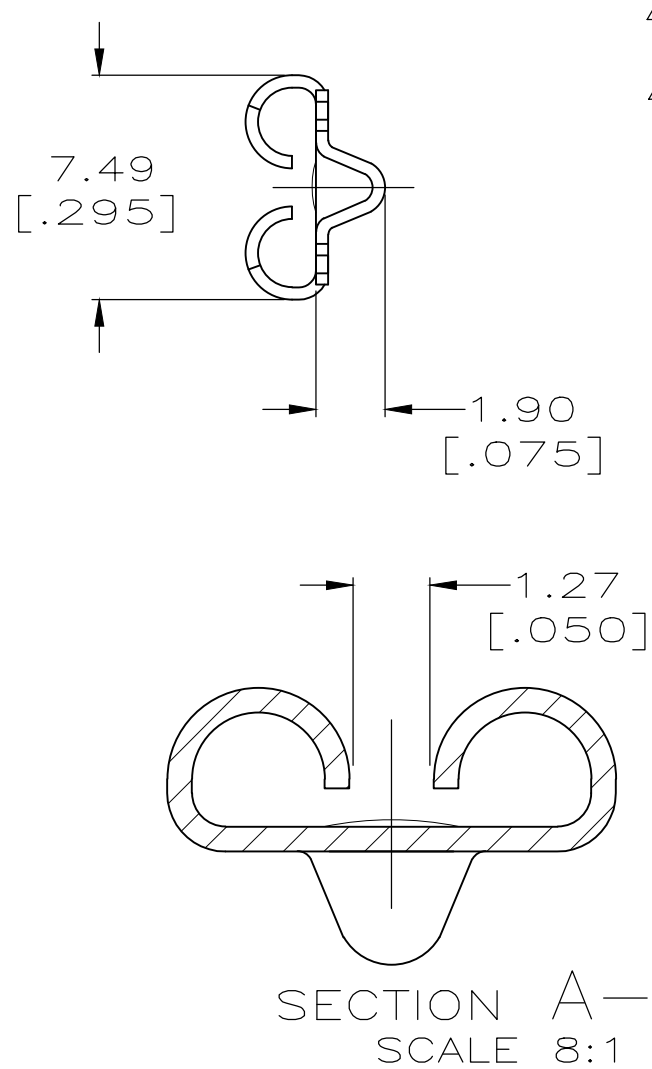

- 1 CONTINUOUS STRIP ON REELS.
- 2 0.00254 [.000100] MIN THK TIN OVER 0.00127 [.000050] MIN NICKEL
- 3 MATING TAB THK IS 0.635±0.025 [.025±.001].
- 4 REELED WITH INTERLEAVING
- 5 PRELIMINARY - NOT FOR PRODUCTION

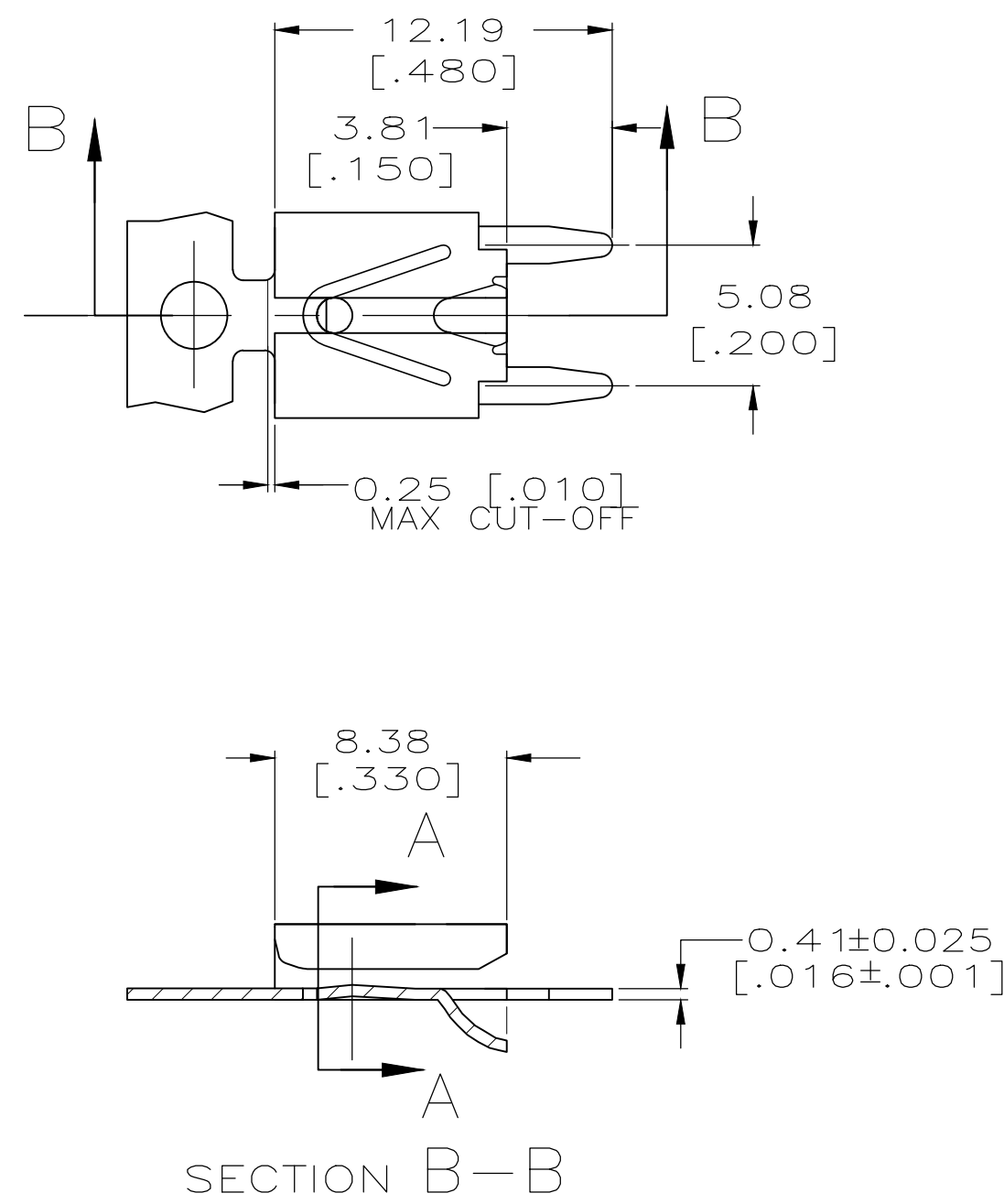
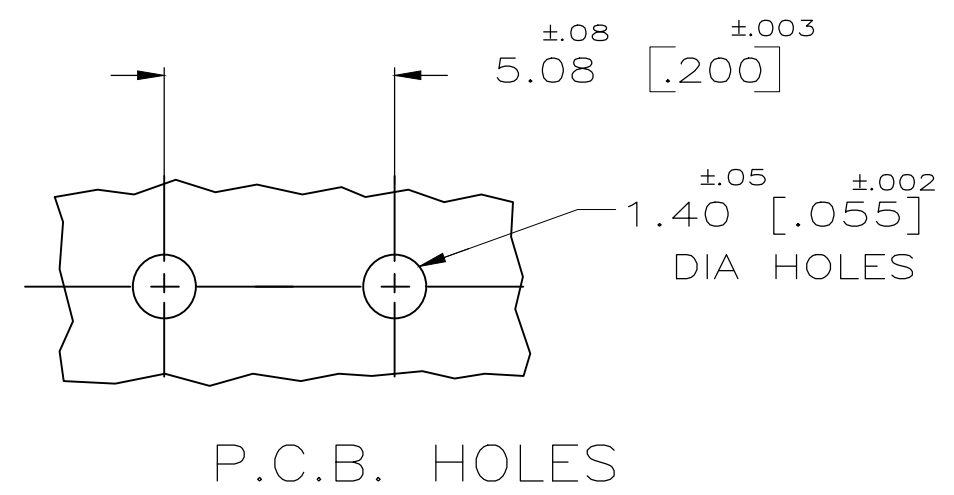

SUPERSEDED BY -1	4	5	63994-2
	4		63994-1
PART NO.			

THIS DRAWING IS A CONTROLLED DOCUMENT.		DWN	JR RUTH	3/12/97	STE TE Connectivity		
DIMENSIONS: MM [INCHES]		CHK	MS FEHER	3/12/97			
TOLERANCES UNLESS OTHERWISE SPECIFIED:		APVD	DAVE BRATINA	3/12/97	NAME		
0 PLC ± -		PRODUCT SPEC		RECEPTACLE, FASTON, 6.35/5.21 [.250/.205] SERIES, PC BOARD MOUNTED			
1 PLC ± -		APPLICATION SPEC		SIZE			
2 PLC ± 0.25 [.010]		FINISH		CAGE CODE		DRAWING NO	
3 PLC ± -		MATERIAL		RESTRICTED TO		SCALE	
4 PLC ± -		H04 BRASS		WEIGHT		SHEET	
ANGLES ± -		TIN OVER NICKEL		0.000000		1 OF 1	
				CUSTOMER DRAWING		REV	
				A3 00779 C-63994		F	