

Spread Spectrum Clock Generator

Features

- 8- to 32-MHz input frequency range
- CY25818: 8–16 MHz
- CY25819: 16–32 MHz
- Separate modulated and unmodulated clocks
- Accepts clock, crystal, and resonator inputs
- Down spread modulation
- Power-down function
- Low-power dissipation
 - CY25818 = 33 mW-typ @ 8 MHz
 - CY25818 = 56 mW-typ @ 16 MHz
 - CY25819 = 36 mW-typ @ 16 MHz
 - CY25819 = 63 mW-typ @ 32 MHz
- Low cycle-to-cycle jitter
 - SSCLK = 250 ps-typ
 - REFOUT = 275 ps-typ
- Available in 8-pin (150-mil) SOIC package

Applications

- Printers and MFPs
- LCD panels and notebook PCs
- Digital copiers
- PDAs
- Automotive
- CD-ROM, VCD, and DVD
- Networking and LAN/WAN
- Scanners
- Modems
- Embedded digital systems

Benefits

- Peak electromagnetic interference (EMI) reduction by 8–16 dB
- Fast time to market
- Cost reduction

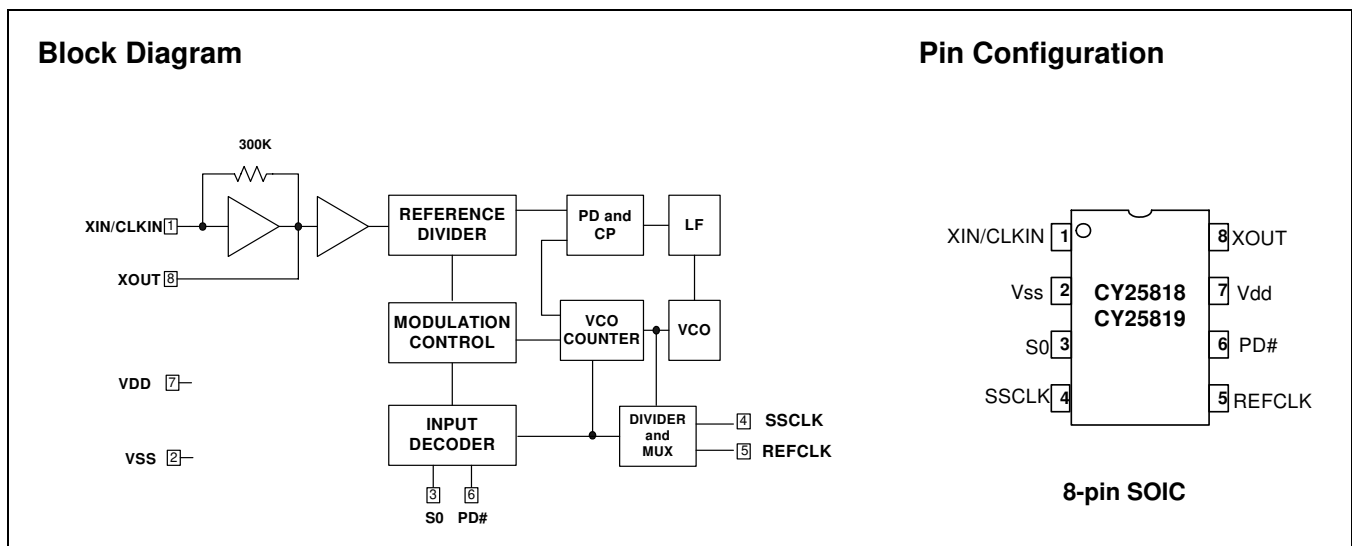

Pin Description

Pin	Name	Description
1	XIN/CLK	Clock, Crystal, or Ceramic Resonator Input Pin.
2	Vss	Power Supply Ground.
3	S0	Digital Spread% Control Pin. 3-Level input (H-M-L). Default = M.
4	SSCLK	Modulated Spread Spectrum Output Clock. The output frequency is referenced to input frequency. Refer to <i>Table 2</i> for the amount of modulation (Spread%).
5	REFCLK	Unmodulated Reference Clock Output. The unmodulated output frequency is the same as the input frequency.
6	PD#	Power-Down Control Pin. Default = H (Vdd).
7	Vdd	Positive Power Supply.
8	XOUT	Clock, Crystal, or Ceramic Resonator Output Pin. Leave this pin unconnected if an external clock is used at X _{IN} pin.

Overview

The Cypress CY25818/19 products are Spread Spectrum Clock Generator (SSCG) ICs used for the purpose of reducing EMI found in today's high-speed digital electronic systems. The devices use a Cypress proprietary phase-locked loop (PLL) and Spread Spectrum Clock (SSC) technology to synthesize and modulate the frequency of the input clock. By frequency modulating the clock, the measured EMI at the fundamental and harmonic frequencies is greatly reduced. This reduction in radiated energy can significantly reduce the cost of complying with regulatory agency requirements and improve time to market without degrading system performance.

The input frequency range is 8–16 MHz for the CY25818 and 16–32 MHz for the CY25819. Both products accept external clock, crystal, or ceramic resonator inputs.

The CY25818/19 provide separate modulated (SSCLK) and unmodulated reference (REFCLK) clock outputs which are the same frequency as the input clock frequency. Down spread frequency modulation can be selected by the user, based on three discrete values of Spread%. A separate power down function is also provided.

The CY25818/19 products are available in an 8-pin SOIC (150-mil) package with a commercial operating temperature range of 0–70°C. Contact Cypress for availability of –40 to +85°C industrial temperature range operation or TSSOP package versions. Refer to the CY25568, CY25811, CY25812, and CY25814 products for other functions such as clock multiplication of 1×, 2×, or 4× to generate a wide range of Spread Spectrum output clocks from 4 to 128 MHz.

Input Frequency Range and Selection

CY25818/19 input frequency range is 8–32 MHz. This range is divided into two segments, as given in *Table 1*.

Table 1. Input and Output Frequency Selection

Product	Input/Output Frequency Range
CY25818	8–16 MHz
CY25819	16–32 MHz

Spread% Selection

CY25818/19 SSCG products provide Down-Spread frequency modulation. The amount of Spread% is selected by using 3-Level S0 digital input. Spread% values are given in *Table 2*.

Table 2. Spread% Selection

XIN (MHz)	Product	S0 = 1	S0 = 0	S0 = M
		Down (%)	Down (%)	Down (%)
8–10	CY25818	–3.0	–2.2	–0.7
10–12	CY25818	–2.7	–1.9	–0.6
12–14	CY25818	–2.5	–1.8	–0.6
14–16	CY25818	–2.3	–1.7	–0.5
16–20	CY25819	–3.0	–2.2	–0.7
20–24	CY25819	–2.7	–1.9	–0.6
24–28	CY25819	–2.5	–1.8	–0.6
28–32	CY25819	–2.3	–1.7	–0.5

3-Level Digital Inputs

S0 digital input is designed to sense three logic levels designated as HIGH “1,” LOW “0,” and MIDDLE “M.” With this 3-Level digital input logic, the 3-Level logic is able to detect three different logic levels.

The S0 pin includes an on-chip 20K (10K/10K) resistor divider. No external application resistors are needed to implement 3-Level logic, as follows.

Logic Level “0”: 3-Level logic pin connected to GND.

Logic Level “M”: 3-Level logic pin left floating (no connection.)

Logic Level “1”: 3-Level logic pin connected to Vdd.

Figure 1 illustrates how to implement 3-Level Logic.

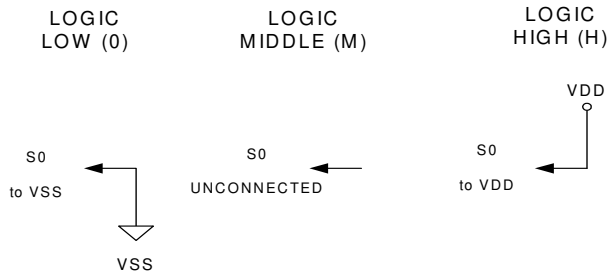

Figure 1. 3-Level Logic

Modulation Rate

Spread Spectrum Clock Generators utilize frequency modulation (FM) to distribute energy over a specific band of frequencies. The maximum frequency of the clock (fmax) and minimum frequency of the clock (fmin) determine this band of frequencies. The time required to transition from fmin to fmax and back to fmin is the period of the Modulation Rate, Tmod. The Modulation Rates of SSCG clocks are generally referred to in terms of frequency, and fmod = 1/Tmod.

The input clock frequency, fin, and the internal divider determine the Modulation Rate.

In the case of CY25818/19 devices, the (Spread Spectrum) Modulation Rate, fmod, is given by the following formula:

$$f_{mod} = f_{IN}/DR$$

where fmod is the Modulation Rate, fIN is the Input Frequency, and DR is the Divider Ratio, as given in Table 3.

Table 3. Modulation Rate Divider Ratios

Product	Input Frequency Range	Divider Ratio (DR)
CY25818	8–16 MHz	256
CY25819	16–32 MHz	512

Maximum Ratings^[1, 2]

Supply Voltage (Vdd):+ 5.5V

Input Voltage Relative to Vdd:..... Vdd + 0.3V

Input Voltage Relative to Vss:..... Vss + 0.3V

Operating Temperature:..... 0°C to + 70°C

Storage Temperature:..... –65°C to + 150°C

Table 4. DC Electrical Characteristics Vdd = 3.3V ±10%, TA = 0°C to +70°C and CL = 15 pF (unless otherwise noted)

Parameter	Description	Conditions	Min.	Typ.	Max.	Unit
Vdd	Power Supply Range		2.97	3.3	3.63	V
V _{INH}	Input HIGH Voltage	S0 Input	0.85 Vdd	Vdd	Vdd	V
V _{INM}	Input MIDDLE Voltage	S0 Input	0.40 Vdd	0.50 Vdd	0.60 Vdd	V
V _{INL}	Input LOW Voltage	S0 Input	0.0	0.0	0.15 Vdd	V
V _{OH1}	Output HIGH Voltage	I _{OH} = 4 ma, SSCLK and REFCLK	2.4	–	–	V
V _{OH2}	Output HIGH Voltage	I _{OH} = 6 ma, SSCLK and REFCLK	2.0	–	–	V
V _{OL1}	Output LOW Voltage	I _{OL} = 4 ma, SSCLK Output	–	–	0.4	V
V _{OL2}	Output LOW Voltage	I _{OL} = 10 ma, SSCLK Output	–	–	1.2	V
C _{IN1}	Input Capacitance	X _{IN} (Pin 1) and X _{OUT} (Pin 8)	6.0	7.5	9.0	pF
C _{IN2}	Input Capacitance	All Digital Inputs	3.5	4.5	6.0	pF
I _{DD1}	Power Supply Current	F _{IN} =8 MHz, no load	–	10.0	12.5	mA
I _{DD3}	Power Supply Current	F _{IN} =32 MHz, no load	–	19.0	23.0	mA
I _{DD4}	Power Supply Current	PD# = Vss	–	150	250	mA

Table 5. Timing Electrical Characteristics V_{DD} = 3.3V ±10%, T_A = 0°C to +70°C and C_L = 15 pF (unless otherwise noted)

Parameter	Description	Conditions	Min.	Typ.	Max.	Unit
ICLKFR1	Input Frequency Range	CY25818	8	–	16	MHz
ICLKFR2	Input Frequency Range	CY25819	16	–	32	MHz
trise1	Clock Rise Time	SSCLK and REFCLK, 0.4V to 2.4V	2.0	3.0	4.0	ns
tfall1	Clock Fall Time	SSCLK and REFCLK, 0.4V to 2.4V	2.0	3.0	4.0	ns
CDCin	Input Clock Duty Cycle	X _{IN}	20	50	80	%
CDCout	Output Clock Duty Cycle	SSCLK and REFCLK @ 1.5V	45	50	55	%
CCJss	Cycle-to-Cycle Jitter	SSCLK; F _{IN} = F _{OUT} = 8–32 MHz		250	350	ps
CCJref	Cycle-to-Cycle Jitter	REFCLK; F _{IN} = F _{OUT} = 8–32 MHz		275	375	ps

Characteristics Curves

The following curves demonstrate the characteristic behavior of the CY25818/19 when tested over a number of environmental and application specific parameters. These are typical performance curves and are not meant to replace any parameter specified in Table 4 and Table 5.

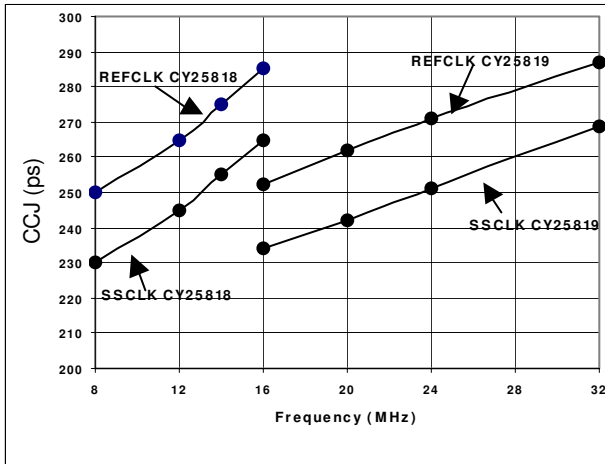

Figure 2. CCJ (ps) vs. Frequency (MHz)

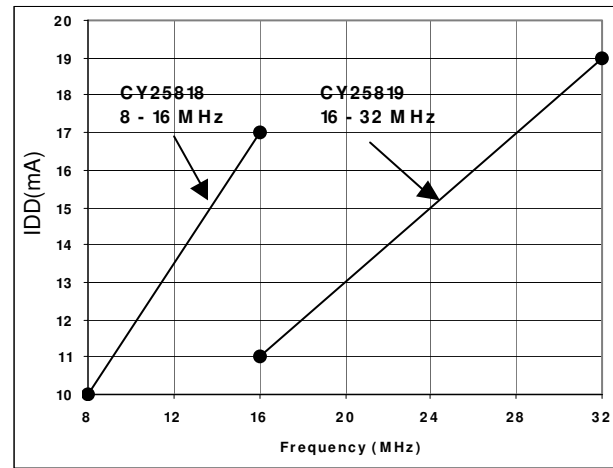

Figure 4. IDD (mA) vs. Frequency (MHz)

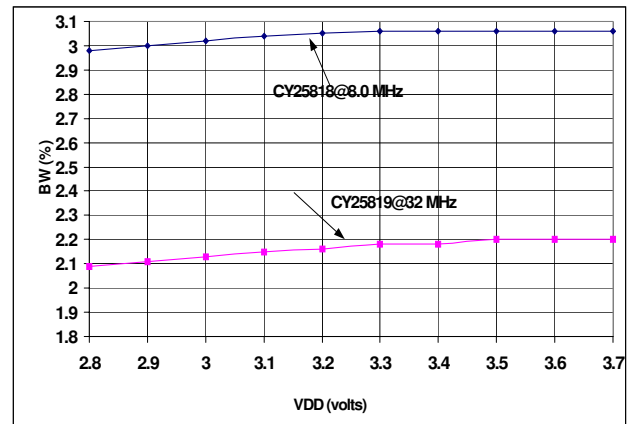

Figure 5. Bandwidth% vs. VDD

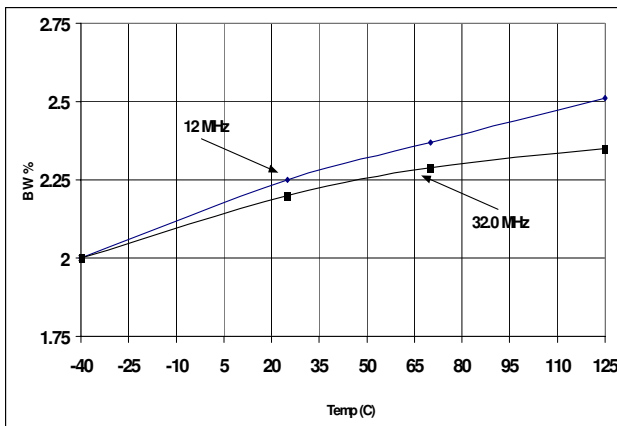

Figure 3. Bandwidth% vs. Temperature

Notes:

1. Single Power Supply: The voltage on any input or I/O pin cannot exceed the power pin during power-up.
2. Operation at any Absolute Maximum Rating is not implied.

SSCG Profiles

CY25818/19 SSCG products use a non-linear “optimized” frequency profile as shown in *Figure 6* and *Figure 7*. The use of Cypress proprietary “optimized” frequency profile maintains flat energy distribution over the fundamental and higher order harmonics. This results in additional EMI reduction in electronic systems.

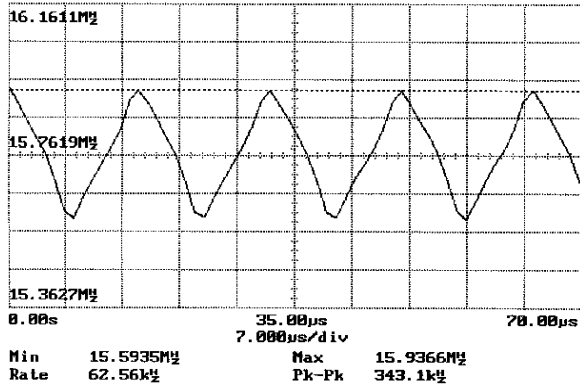

Figure 6. CY25818 Spread Spectrum Profile (Frequency vs. Time)^[3]

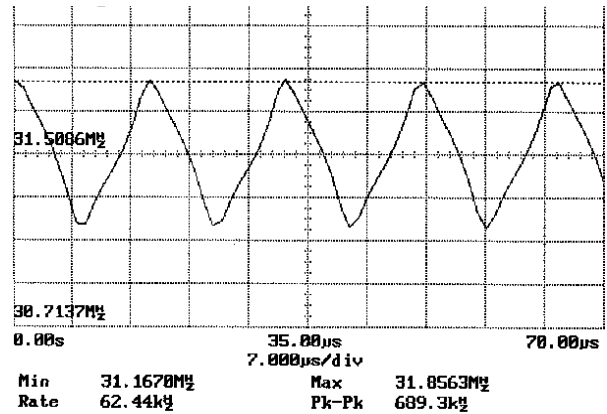

Figure 7. CY25819 Spread Spectrum Profile (Frequency vs. Time)^[4]

Application Schematic

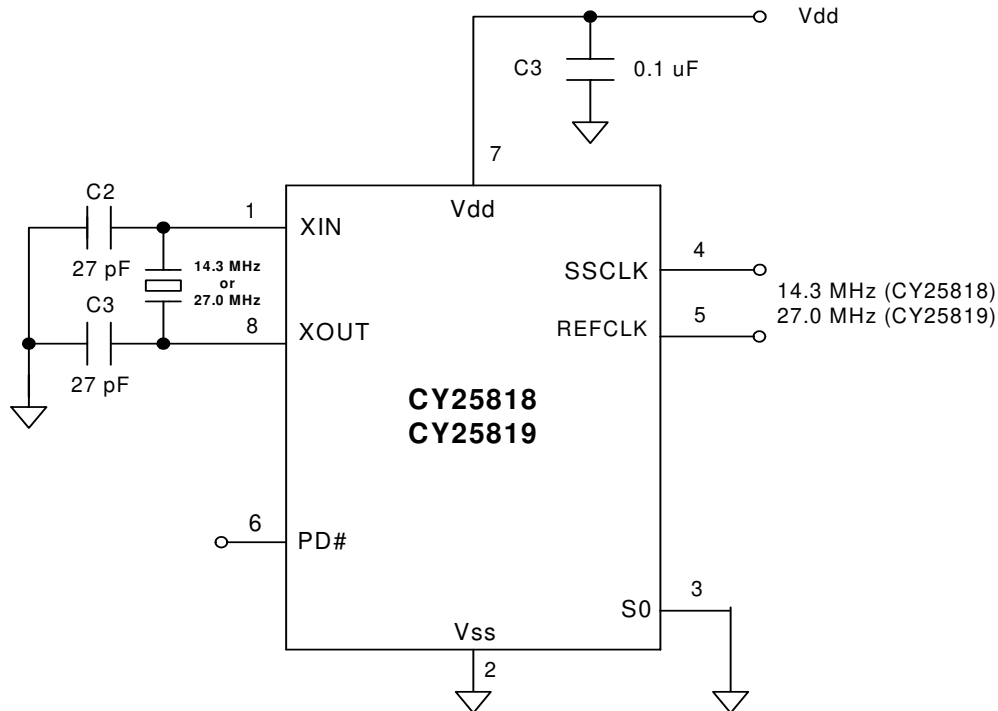

Figure 8. Typical Application Schematic

Notes:

- 3. X_{IN} = 16.0 MHz; S0 = 1; SSCLK = 16.0 MHz; BW = -2.14%.
- 4. X_{in} = 32.0 MHz; S0 = 1; SSCLK = 32.0 MHz; BW = -2.15%

Ordering Information

Part Number	Package Type	Product Flow
CY25818SC	8-pin SOIC	Commercial, 0° to 70°C
CY25818SCT	8-pin SOIC–Tape and Reel	Commercial, 0° to 70°C
CY25819SC	8-pin SOIC	Commercial, 0° to 70°C
CY25819SCT	8-pin SOIC–Tape and Reel	Commercial, 0° to 70°C
Lead-free		
CY25818SXC	8-pin SOIC	Commercial, 0° to 70°C
CY25818SXCT	8-pin SOIC–Tape and Reel	Commercial, 0° to 70°C
CY25819SXC	8-pin SOIC	Commercial, 0° to 70°C
CY25819SXCT	8-pin SOIC–Tape and Reel	Commercial, 0° to 70°C

Package Drawing and Dimensions

8-lead (150-Mil) SOIC S8

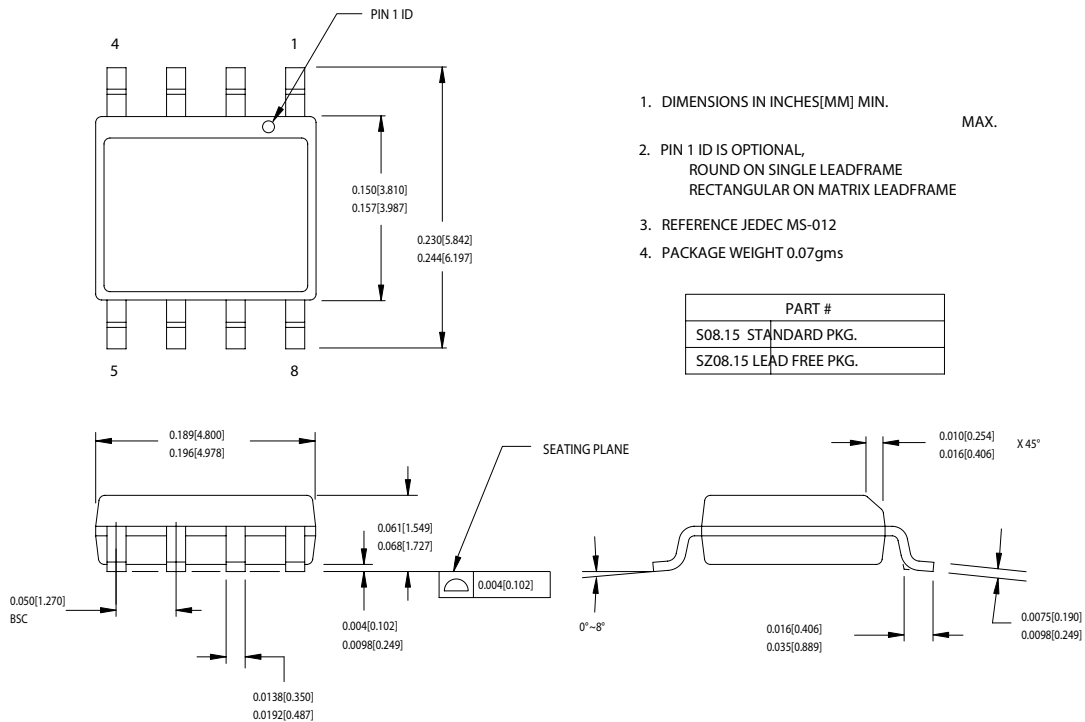

1. DIMENSIONS IN INCHES[MM] MIN. MAX.
2. PIN 1 ID IS OPTIONAL, ROUND ON SINGLE LEADFRAME RECTANGULAR ON MATRIX LEADFRAME
3. REFERENCE JEDEC MS-012
4. PACKAGE WEIGHT 0.07gms

51-85066-C

All product and company names mentioned in this document may be the trademarks of their respective holders.

Document History Page

Document Title: CY25818/19 Spread Spectrum Clock Generator
Document Number: 38-07362

REV.	ECN NO.	Issue Date	Orig. of Change	Description of Change
**	112462	03/21/02	OXC	New Data Sheet
*A	122701	12/28/02	RBI	Added power up requirements to maximum rating information.
*B	448097	See ECN	RGL	Add Lead-free devices