

8 | 7 | 6 | 5 | 4 | 3 | 2 | 1

DO NOT SCALE DIMENSIONS IN MM. 

U.A.D. FILE CODE
S.C344070.A

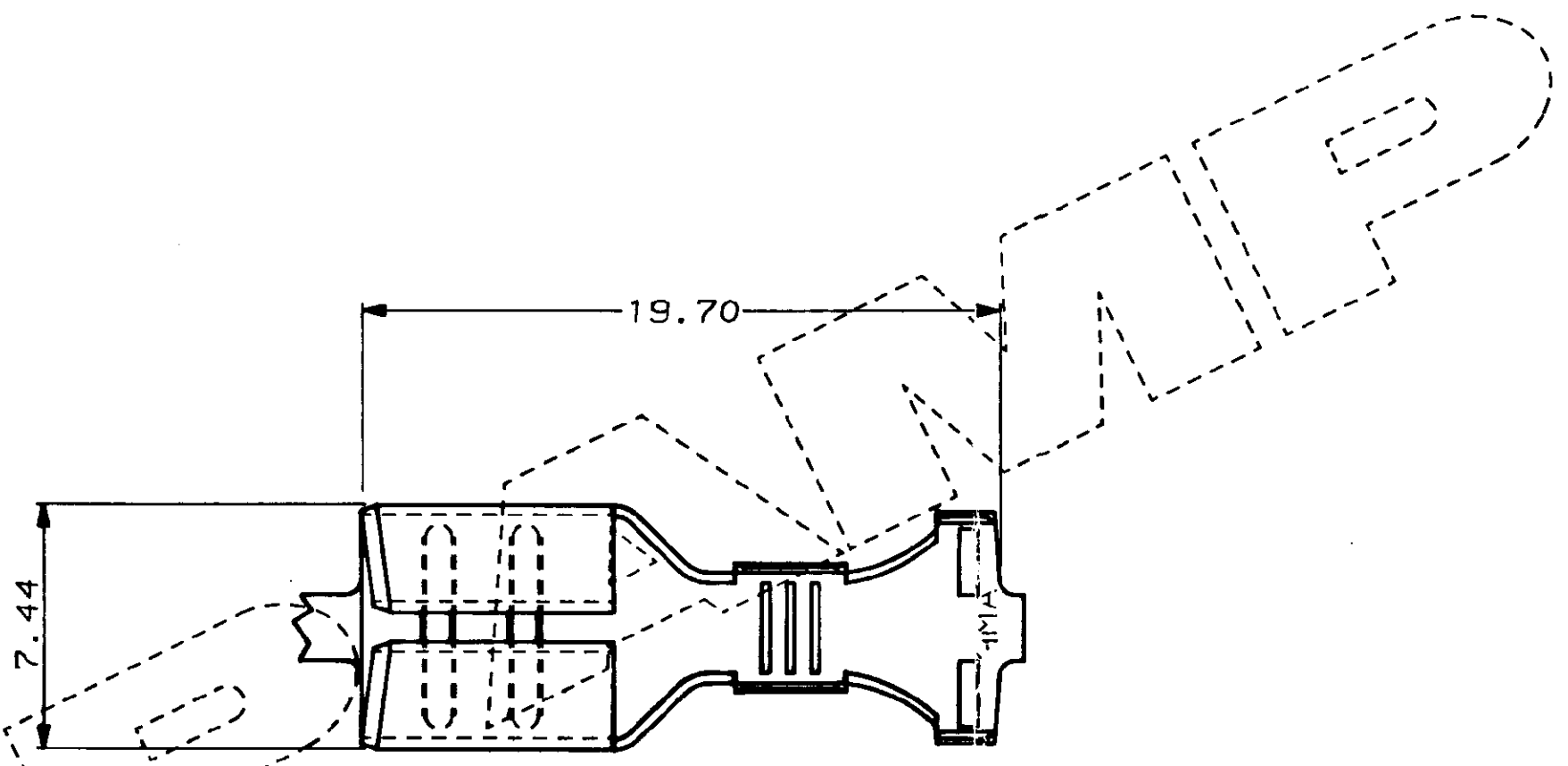

GAP TO SUIT 0.81 TAB

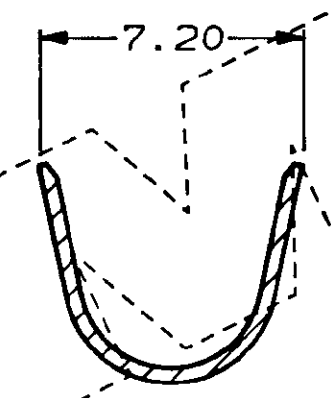
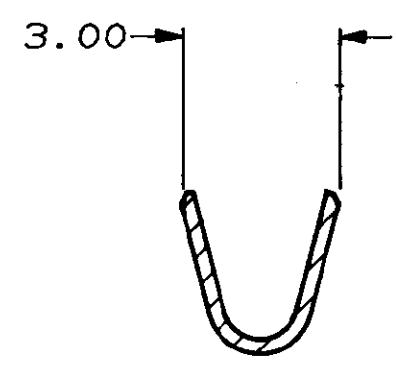
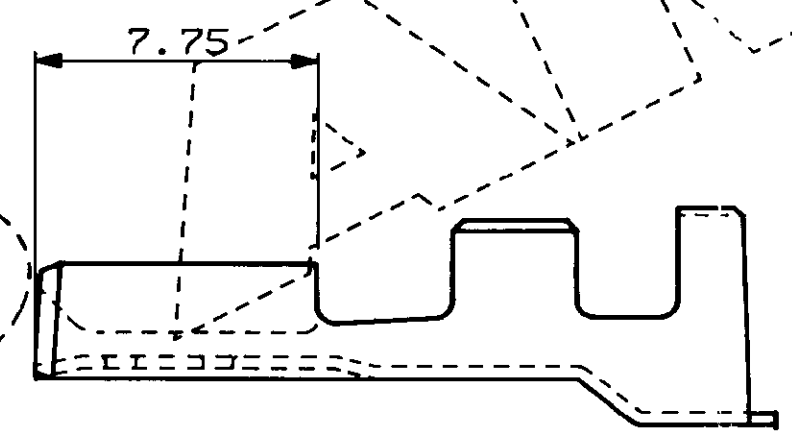
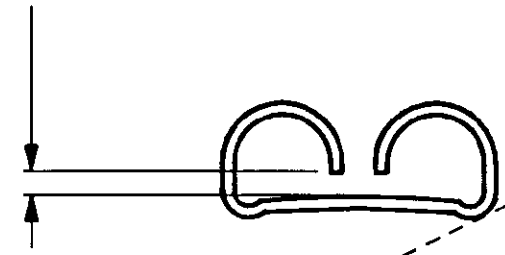

WIRE RANGE 0.50 TO 1.50 MM²
 INS. RANGE 4.10 TO 5.50 MM DIA. INC. SEAL
 (ONLY THIN WALLED CABLE 1.60 TO 2.40 MM DIA. IS SUITABLE)

| | | | | | |
|------------------------------------|--------------|--|---------|--|----------|
| TIN PLATED | | BRASS | | 344070-1 | |
| FINISH | | MATERIAL | | PART NUMBER | |
| CUSTOMER DWG FOR REFERENCE ONLY | | ©COPYRIGHT 1987 BY AMP OF GREAT BRITAIN LTD. ALL INTERNATIONAL RIGHTS RESERVED. ALL PRODUCTS MAY BE COVERED BY BRITISH AND FOREIGN PATENTS AND/OR PATENTS PENDING. | | 24/06/87 DR. R. RUNAGALL. | |
| - | | TOLERANCES UNLESS OTHERWISE STATED : | | APP. B. J. | |
| - | | DEC ± 0.5 | |  TERMINAL HOUSE STANMORE MIDDX. | |
| - | | ANGLES ± 1° | | NAME .250 SERIES REC. HIGH CURRENT | |
| - | | | | ECONOSEAL 3 (SEALED APPLICATIONS) | |
| B | EBAO-0029-03 | R.S. | 12.8.03 | SCALE | LOC |
| REV | ECN | DRN | DATE | 5/1 | E |
| | | | | SIZE | DWG. No. |
| | | | | A2 | C344070 |
| | | | | REV | SHEET |
| | | | | B | 1/1 |

FORMAT 22/05/85 8 | 7 | 6 | 5 | 4 | 3 | 2 | 1