

PART NUMBER	REV	FIRST USED
680334-1	C	122500-1
680334-2	C	565435-5

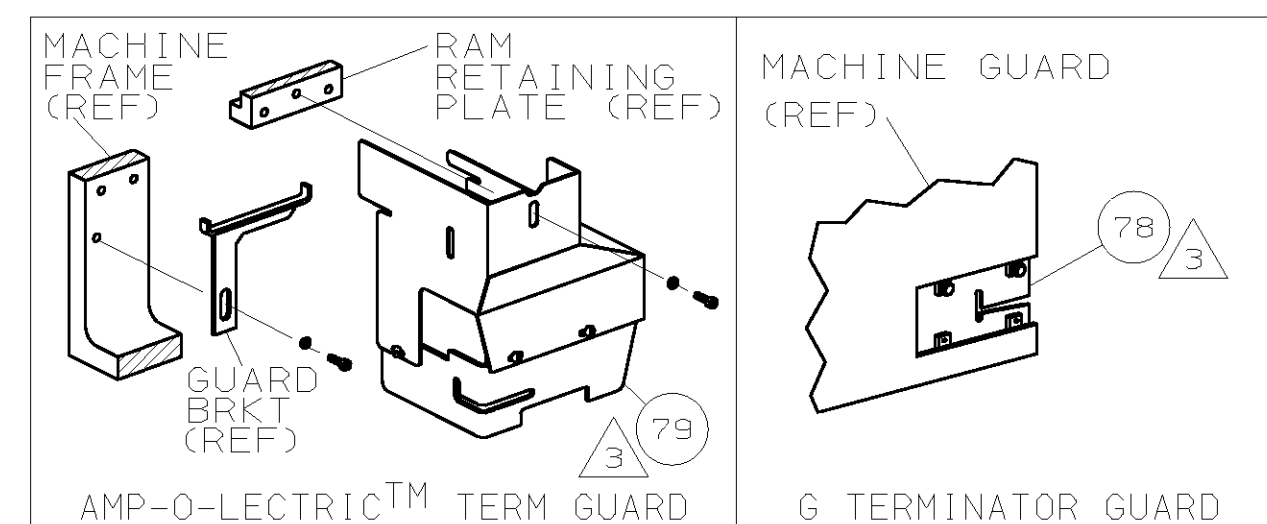

TERMINAL NAME:	SPECIAL	TERMINAL	CRIMPING DATA			
	63671 61462		PAD LTR	CRIMP HEIGHT	WIRE SIZE	
			A	.071 ±.002 [1.80 ±0.05mm]	18	
			B	.066 ±.002 [1.68 ±0.05mm]	22	
			C	NOT	USED	
			D	NOT	USED	
			CRIMP	SIZE	TYPE	RANGE
			WIRE			
			INSUL	.120 [3.05mm]	BLUNT F	.085
WIRE STRIP LENGTH	TERM APPL SPEC	FEED	APPL INSTRUCTION	SET UP GAGE	LAYOUT	
-	NONE	.717	408-8039	458638-1	L1792	

-1	LEADMAKER & BENCH MODEL G	MECH POST FEED	
-2	BENCH MODEL K	MECH POST FEED	

REF	REF	-	A	22594-8	NUT, HEX	70
REF	REF	-	B	240628-1	PLATE, ADJ	69
REF	REF	-	B	240626-1	SHAFT, PIVOT	68
REF	REF	-	B	240633-1	BUSHING	67
REF	REF	-	A	455680-1	LEVER, INTERMEDIATE	66
REF	REF	-	B	240629-1	BLOCK, PIVOT	65
REF	REF	-	A	240632-2	SCR, ADJ	64
REF	REF	-	B	240659-3	PIN, CAM ROLLER	63
REF	REF	-	B	240658-1	CAM, ROLLER	62
REF	REF	-	B	454398-1	ROD, FEED	61
REF	REF	-	C	454220-1	CAP, RAM	59
REF	REF	-	D	453736-1	HOUSING	58
						57
						56
REF	REF	-	B	240624-1	PIN, FEED FINGER	55
REF	REF	-	B	691499-1	SPRING, FEED FINGER	54
REF	REF	-	B	240635-1	FINGER, FEED	53
REF	REF	-	B	240634-1	LEVER, TERMINAL	52
						51
						50
						49
1	-	-	B	690501-3	CAM, POST FEED 1 1/8 ST	48
-	1	-	B	690501-4	CAM, POST-FEED 1 5/8 ST	47
						46
1	1	-	A	690191-1	PLUG, NYLON	45
1	1	-	C	455674-1	RAM	44
1	1	-	A	690125-1	WASHER, LAMINATED	43
1	1	-	A	690124-1	WASHER, RAM	42
1	1	-	A	7-21002-9	BOLT, CRIMPER (5/16-24x1.00)	41
						40
						39
1	1	-	C	690223-2	SPACER, INSULATION DISC	38
1	1	-	D	354777-1	WIRE DISC, PLASTIC	37
1	1	-	A	22480-5	WASHER, SPRING	36
1	1	-	B	690212-1	POST, RAM	35
						34
						33
1	1	-	D	458980-1	APPLICATOR, BASIC (SUB ASSY)	32
						31
						30
						29
1	1	-	B	4-690451-7	SPACER, STRIPPER	28
REF	REF	-	A	240639-2	STRIPPER	27
REF	REF	-	C	455676-1	PLATE, BASE	26
2	2	-	A	22354-8	DRAG, STUD	25
1	1	-	B	455678-1	PLATE, STRIP GUIDE	24
1	1	-	C	240825-1	PLATE, STRIP HOLD DOWN	23
2	2	-	A	4-22281-1	SPRING, DRAG	22
						21
1	1	-	A	454177-1	DRAG, STOCK	20
						19
2	2	-	C	454204-3	GUIDE, STRIP (FRONT)	18
REF	REF	-	A	454178-1	GUIDE, FEED ROD	17
REF	REF	-	A	4-22284-9	SPRING, FEED RETURN	16
						15
						14
						13
1	1	-	A	23846-1	SPRING, HOLD DOWN	12
1	1	-	B	240644-1	PLATE, REAR SHEAR	11
						10
1	1	-	B	690482-6	PLATE, FRONT SHEAR	9
1	1	-	D	454435-6	ANVIL	8
1	1	-	B	690474-6	BLADE, SLUG	7
1	1	-	D	1-455892-5	HOLD DOWN, TERMINAL	6
1	1	-	C	7-240641-1	SPACER, SLUG BLADE	5
						4
1	1	-	C	1-459585-6	CRIMPER, INSULATION	3
						2
						1

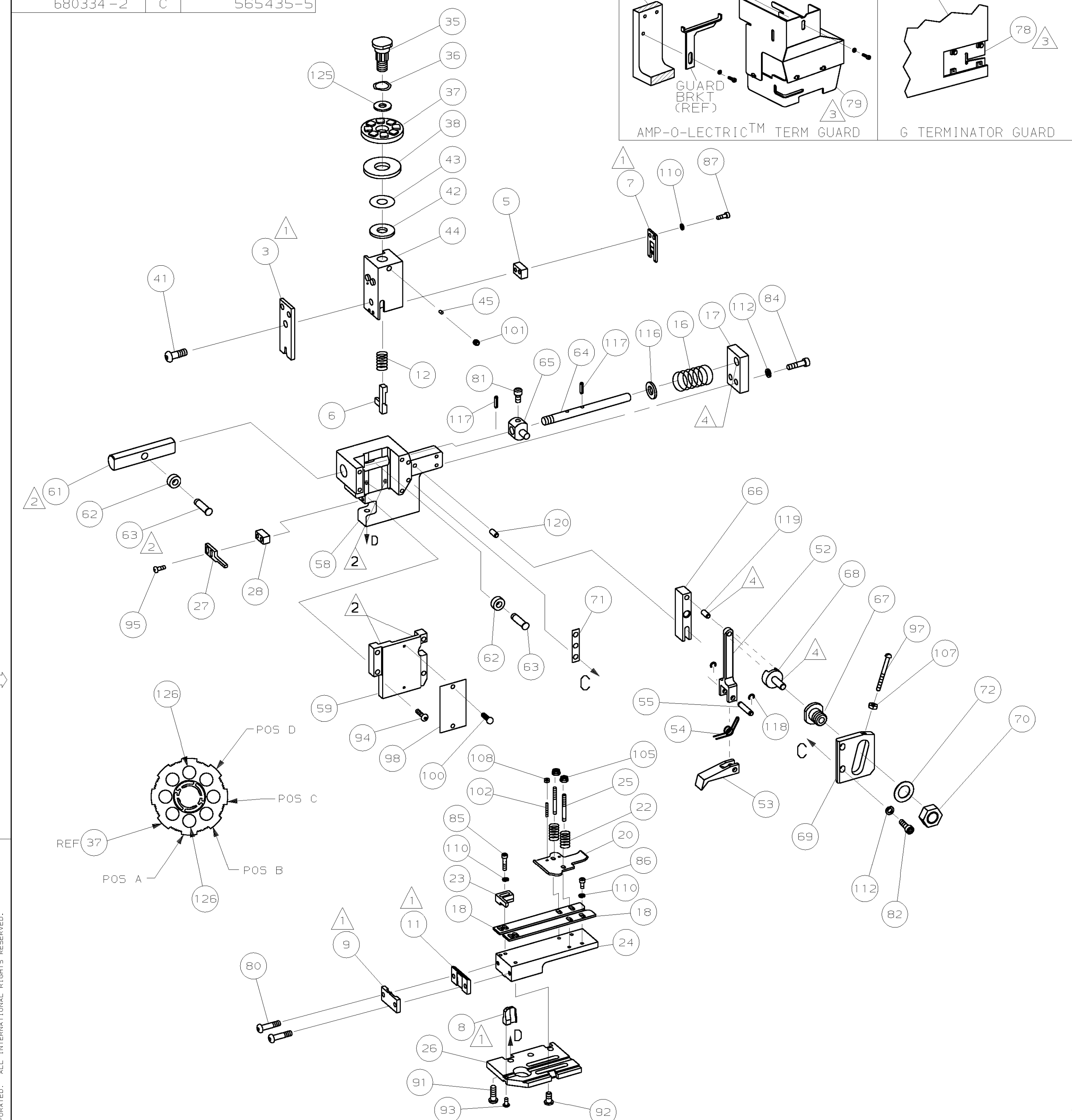

						129
						128
2	2	-	C	8-354778-2	PIN, WIRE DISC (.2905)B	127
2	2	-	C	7-354778-4	PIN, WIRE DISC (.2865)A	126
1	1	-	A	986950-1	WASHER, FLAT PRECISION	125
1	1	-	A	217238-1	GENERAL INSTRUCTION PACKAGE	124
1	1	-	-	4088039	EF APPL INST 408-8039	123
						122
						121
REF	REF	-	A	1-21030-7	PIN, DOWEL (Ø.187x1.50)H56	120
REF	REF	-	A	1-21030-1	PIN, DOWEL (Ø.187x.50)LEVER	119
REF	REF	-	A	21045-3	RING, RET "C" (Ø.187)FD PIN	118
REF	REF	-	A	5-21028-1	PIN, STD SPRING (Ø.12)FD ADJ ROD	117
REF	REF	-	A	21899-4	WASHER, FLAT (Ø5/16) SCR ADJ	116
						115
						114
						113
REF	REF	-	A	21024-5	WASHER, LOCK (NO.10)FD ROD GDE	112
						111
7	7	-	A	21024-4	WASHER, LOCK (NO.8)SHEAR BL	110
						109
2	2	-	A	21018-4	NUT, HEX (4-40)DRAG	108
REF	REF	-	A	21018-5	NUT, HEX (6-32)FD ADJ PL	107
						106
2	2	-	A	21022-2	NUT, HEX SL (8-32)DRAG STUD	105
						104
						103
2	2	-	A	2-21006-6	SCR, SKT SET (4-40x.62)DRAG	102
1	1	-	A	21009-2	SCR, SKT SET (1/4-20x.25)RAM	101
2	2	-	A	21017-2	SCR, DRIVE (#2x.19) ID PLATE	100
1	1	-	A	1-21002-7	SCR, BHC (6-32x.38)CAM	99
1	1	-	B	461264-1	PLATE, IDENTIFICATION	98
REF	REF	-	A	6-23715-5	SCR, PAN HD (6-32x1.50)FEED ADJ	97
						96
2	2	-	A	2-21002-2	SCR, BHC (8-32x.50)STRIPPER	95
REF	REF	-	A	2-21002-9	SCR, BHC (10-32x.75)H56 CAP	94
1	1	-	A	22733-8	SCR, BHC (8-32x.38 LW)ANVIL	93
4	4	-	A	3-21002-3	SCR, BHC (1/4-20x.50)ST 6D PL	92
REF	REF	-	A	2-22733-8	SCR, BHC (1/4-20x.62)BASE PL	91
						90
						89
						88
2	2	-	A	2-21000-7	SCR, SHC (8-32x.50)SLUG BLADE	87
3	3	-	A	2-21000-6	SCR, SHC (8-32x.38)STRIP GUIDE	86
2	2	-	A	2-21000-8	SCR, SHC (8-32x.62)R STRIP GUIDE	85
REF	REF	-	A	3-21000-7	SCR, SHC (10-32x.75)FEED ROD GDE	84
						83
REF	REF	-	A	3-21000-6	SCR, SHC (10-32x.62)FEED ADJ PL	82
REF	REF	-	A	3-21000-4	SCR, SHC (10-32x.38)PIVOT BLOCK	81
2	2	-	A	3-21002-0	SCR, BHC (10-32x.88)SHEAR PL	80
REF	-	-	A	455745-1	GUARD, WINDOW	79
-	REF	-	A	679532-1	INSERT, GUARD	78
						77
						76
						75
						74
						73
REF	REF	-	A	458109-1	WASHER, FLAT (SPECIAL)	72
REF	REF	-	A	690517-1	SPACER	71
						70
						69
						68
						67
						66
						65
						64
						63
						62
						61
						60
						59
						58
						57
						56
						55
						54
						53
						52
						51
						50
						49
						48
						47
						46
						45
						44
						43
						42
						41
						40
						39
						38
						37
						36
						35
						34
						33
						32
						31
						30
						29
						28
						27
						26
						25
						24
						23
						22
						21
						20
						19
						18
						17
						16
						15
						14
						13
						12
						11
						10
						9
						8
						7
						6
						5
						4
						3
						2
						1

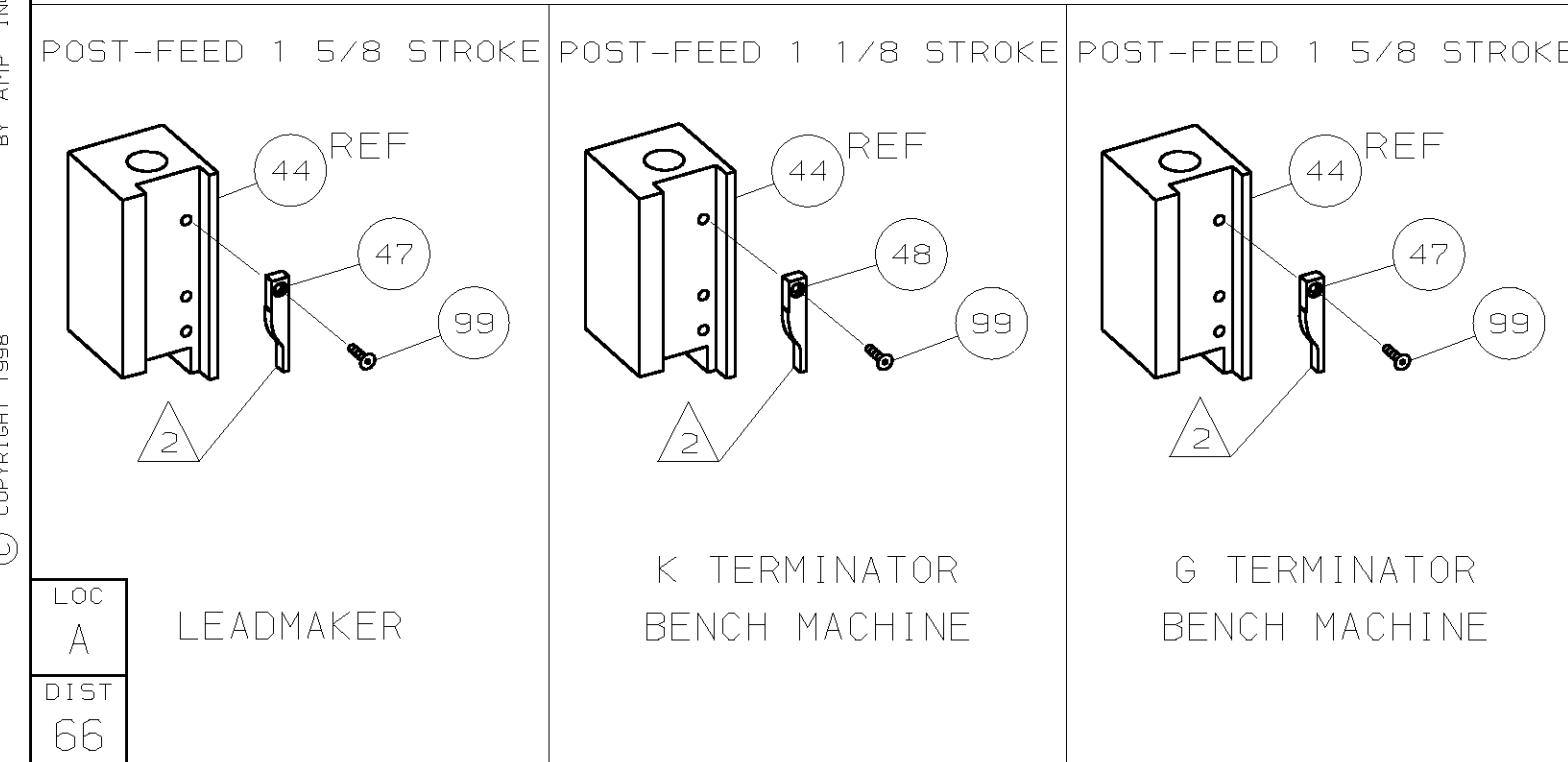

- 1 RECOMMENDED SPARE PARTS.
- 2 GREASE LIGHTLY.
- 3 GUARD MUST BE IN PLACE WHEN OPERATING APPLICATOR IN A BENCH MACHINE.
- 4 LUBRICATE DAILY USING NO. 20 MACHINE OIL.
- 5. ITEMS WITH QTY OF REF SPECIFIED (EXCEPT ITEMS 78 AND 79) ARE USED ON ITEM 32.
- 6 ITEM 78 USED WITH 6 TERMINATOR ONLY.
- 7 USE CUSTOMER WIRE FOR SET-UP.