

38999+ plus

Infinite Options Beyond the Mil-Spec Limits

FOR MILITARY, AEROSPACE AND HARSH ENVIRONMENTS



Amphenol
Aerospace

About Amphenol Aerospace

Your Source for Interconnect Products

Amphenol Aerospace

Contact Us:

Amphenol Aerospace
40-60 Delaware Avenue
Sidney, NY 13838-1395

Customer Service:

Mon - Fri 8AM - 5PM
Phone: (800) 678-0141
Fax: (607) 563-5157

Online: www.amphenol-aerospace.com



*Amphenol Aerospace, Amphenol Commercial Air,
and Amphenol Industrial Operations Main Facility in Sidney, NY USA*

About Amphenol Aerospace:

Amphenol Aerospace, a Division of Amphenol Corporation, is one of the largest manufacturers of interconnect products in the world for the Military, Commercial Aerospace and Industrial markets. Amphenol designs, manufactures and markets circular and rectangular, electronic, fiber optic, EMI/EMP filter, and a variety of special applications connectors and interconnect systems.

Our state-of-the-art facility is nestled at the foothills of the Catskill Mountains in Sidney, NY. The Amphenol complex houses many technologies including CNC machining, die-casting, molding, impact and extruding, plating, screw machining and process controls. Our fully equipped material evaluation lab and engineering organization utilize the latest in computer aided design software and analysis tools, allowing us to design, test, and qualify advanced interconnect systems. Amphenol's interconnect products are supplied to thousands of OEMs worldwide and are supported by our worldwide sales and engineering force, including the largest global network of electronic distributors.



Customer-Centric:

Our **#1 priority** is our customers who deserve quality product on time.

Accountable:

Clear owners, clear actions, clear results.

Reliable:

What we build matters and quality is imperative.

Enthusiastic:

Challenges create rewarding opportunities. Enthusiasm is contagious and we will spread it.

Quality Assurance:

Amphenol Aerospace has been awarded both AS9100 - Revision C and ISO9001:2008 Quality Assurance Certifications.

Contents

PCB	About Amphenol® Aerospace	1
	Infinite Possibilities/Beyond the Mil-Spec	4-5
	Shell Styles	6
	Amphenol RoHS Compliant Platings: Alternative to Cadmium	7
	MIL-DTL-38999, Series III TV: Finish Data	8
HD	38999 PCB Connectors	9
	PCB D38999, Series III TV: How to Order (Commercial)	10
Power	Wall Mounting Receptacles: Back Panel Mounting TVP00, TVPS00, CTVP00, TVP10, TVPS10	11
	Wall Mounting Receptacles with Clinch Nuts: Back Panel Mounting TVP10, TVPS10, CTVP10 & CTVPS10	12
	Wall Mounting Double Flange Receptacles: TVP40, TVPS40, CTVP40 & CTVPS40	13
	Box Mounting Receptacles: TVP02, TVPS02, CTVP02 & CTVPS02	14
Bulk	Box Mounting Receptacles with Clinch Nuts: TVP12 & TVPS12	15
	Jam Nut Receptacles: TV07, TVS07, CTV07 & CTVS07	16
	Jam Nut, Double Flange Receptacles: TV47 & TVS47	17
Integral	Reduced Flange Jam Nut Receptacles: TV97, TV 98	18
	38999 PCB Connector with Ground Pins	19
Plug	Series III High Density Interconnects	20
	High Density Interconnects: How to Order	21
Hermetic	Tri-Power with RADSOK® Technology	22
	Tri-Power with Radsok Contacts: How to Order	23
Speed	Bulkhead Feed-Through, Connector Savers & Plug Adapters	24
	Bulkhead Feed-Through & Connector Savers: How to Order (Ex: BTV07RW-21-35SPB)	25
	Bulkhead Feed-Through Connectors: BTV00-Wall Mount, BTV10 Wall Mount with Clinch Nuts, BTV01-Line Mount	26
	Bulkhead Feed-Through Connectors: BTV07 - Jam Nut	27
Filter	Plugs: 38999 Connectors with Integral Accessories	28
	Connectors with Integral Accessories: How to Order	29
	Plug with Integral Banding Platform: TV96, TVS96	30
	Jam Nut with Integral Banding Platform: TV87, TVS87	30
Access	Wall Mount with Integral Banding Platform: TVP80, TVPS80: Plug with Integral Strain Relief: TV76, TVS76	31
Tech	High Vibration Dualok	32
	High Vibration Dualok, 38999 Series III Type: How to Order (TV56, TVS56)	33
	High Vibration Dualok 38999 Series III Type: Plug (TV56, TVS56, CTV56, CTVS56)	34
	38999 Series III, TV, Plugs: How to Order (Commercial)	35
	RotoLok High Vibration Plug Solutions Wing Nut Plug with Integral Banding Platform	36
	TV Breakaway Fail-Safe Lanyard Release: Commercial Versions	37
	TV Breakaway Fail-Safe Lanyard Release: Commercial (725010, 725014, 725041) Version of D38999/31 Type 6	38
	TV Breakaway Fail-Safe Lanyard Release: Commercial (725010) Version of D38999/31 Type 6	39
	TV Breakaway Fail-Safe Lanyard Release	40
	Commercial (725014 & 725041) Version of D38999/31 Type 6	41
	TV Breakaway Fail-Safe Lanyard Release Plug: (88-5565 & 91-5565) Commercial Version of D38999/29 and /30	42
	PCB Hermetic Series III, D38999	43
	PCB Hermetic Box Mounting Receptacle	44
	PCB Hermetic Jam Nut Receptacle	45
	PCB Hermetic Solder Mounting Receptacle	46
	PCB Hermetic Weld Mounting Receptacle	47

AmpheSEAL: 38999 High Pressure Solution	47
Ground Plane Connectors: Coax/Triax/Twinax	48
OCS (Oval Contact System: Newest 38999 Style Connector	49
OCS (Oval Contact System) Connectors: BTVContact Eye Pattern at 10 Gbps	50
OCS (Oval Contact System) Connectors: How to Order	51
OCS (Oval Contact System) Connectors: Insert Arrangements - Front face of pins illustrated	52
OCS (Oval Contact System) Connectors: TVP00 - Crimp, Metal & CTVP00 - Crimp, Composite Wall Mounting	53
TV07R-Crimp, Metal & CTV07R-Crimp, Composite Jam Nut Receptacle	53
Quadrax Contacts	54
How to Order D38999, Series III Connectors with Standard 100 Ohm Quadrax Contacts.....	55
Octonet Contacts: Superior Ethernet Contact System for 38999, Series III	56
Octonet Contacts: Superior Ethernet Contact System for MIL-DTL-38999, Series III	57
Signal Integrity Contact Data: Insertion and Return Loss	58
Fiber Optic Connectors: 38999 Style	59
Multi Channel Fiber Optic Tri-Start: How to Order	60
MT38999 connectors and fiber optic cable assemblies.....	61
MT38999 Connectors: How to Order.....	62
MT38999 Fiber Optic Cable Assemblies: How to Order	63
Filter Section	64
How to Order - Standard: Filter Connectors	65
How to Order - Special: Filter Connectors (EMI Check Sheet).....	66-67
Connector Accessories	68
MIL-DTL-38999, Series III TV: Receptacle Protection Cap	69
MIL-DTL-38999, Series III TV: Plug Protection Cap	70
MIL-DTL-38999, Series III TV: Wall Mount Dummy Receptacle	71
MIL-DTL-38999, Series III TV: Jam Nut Dummy Receptacle	72
MIL-DTL-38999, Series III TV: Universal "Header Assembly" for Flex Print or PC Board	73
MIL-DTL-38999, Series III TV: Universal "Header Assembly" for Flex Print or PC Board	74
Technical Data	
MIL-DTL-38999, Series III TV, HD: Insert Availability and Identification Chart.....	75-77
MIL-DTL-38999, Series III TV, HD: Insert Arrangements	78-82
MIL-DTL-38999, Series III TV: Special Insert Arrangements	83
Alternate Keying Information	84
MIL-DTL-38999, Series III TV, HD: Contact Ratings/ Service Ratings.....	85
MIL-DTL-38999, Series III TV: Service Rating/Sealing Plugs	86

PCB
HD
Power
Bulk
Integral
Plug
Hermetic
Speed
Filter
Access
Tech

INFINITE OPTIONS

Amphenol Aerospace is the industry leader in the design and development of D38999 Series III connectors. While the qualified Mil-Spec versions offer plenty of features, the customization and design options outside of the Mil-Spec are virtually endless. This catalog collects many of these customized options while offering additional ways to take advantage of the most popular circular connector in the military and aerospace industries.

PCB

HD

Power

Bulk

Integral

Plug

Hermetic

Speed

Filter

Access

Tech

38999 + PCB Tails



**38999 + PCB Tails
+ Double Flange**



**38999 + Reduced
Flange Receptacle**



**38999 + PCB Tails
+ Ground Pins**



38999 + High Density



38999 + Power



**38999 +
Connector Saver**



**38999 + Integral
Accessories**



**38999 +
High Vibration Plug**



BEYOND THE MIL-SPEC LIMITS

Amphenol Aerospace offers the largest range of 38999 connectors on the market and manufactures many different types beyond the Mil-Spec limits. See our separate D38999 Circular Catalog for all of our Mil-Spec Offerings.

**38999 + Breakaway
Fail-Safe Lanyard
Release**



**38999 + PCB Tails
+ Hermetics**

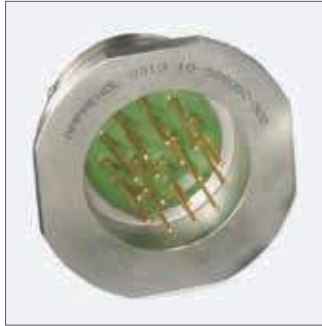

**38999 + High Pressure
Solutions**



38999 + High Speed



**38999 +
Data Transmissions**



38999 + Fiber Optics



38999 + Filtering



38999 + Accessories



**38999 + Custom
Materials and Finishes**



PCB

HD

Power

Bulk

Integral

Plug

Hermetic

Speed

Filter













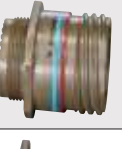







Access

Tech

Shell Style Quick Reference

Shell Styles:

Amphenol's standard and derivative 38999 Plus products are intermateable with all industry standard D38999 solutions. Amphenol offers a vast array of 38999 style options which can be found in the table below. If your design requires a custom solution contact Amphenol Aerospace for further options.

PCB	TVP00 - Pg 11 Wall Mount Receptacle		TVP40 - Pg 13 Double Flange Wall Mount		TV18 Flush Flange	
HD	TV01 Line Receptacle		TV42 Wall Mount with Integrated Helicoils		TV96 - Pg 30 Plug with Integral Banding Platform	
Power	TVP02 Box Mount Receptacle		TV47 & TV47-Pg 17 Double Flange Jam Nut		TV87 - Pg 30 Jam Nut with Integral Banding Platform	
Bulk	TV06 Straight Plug		TV97 - Pg 18 Reduced Flange Jam Nut		TVP80 - Pg 32 Wall Mount with Integral Banding Platform	
Integral	TV07 Jam Nut Receptacle		TV98 - Pg 18 Reduced Flange Jam Nut with Standoff		TV76 - Pg 31 Plug with Integral Strain Relief	
Plug	TV56 - Pg 33 Dualok Plug		TV48 - Reduced Flange Jam Nut with Standoff			
Hermetic	TV09 Flange Mounting Plug		TVP10 & 11 - Pg 12 Wall Mount with Clinch Nuts (self-locking)			
Speed	Deep Reach Receptacle		TVP12 & 13 - Pg 15 Box Mount with Clinch Nuts (self-locking)			
Filter	Solder Mount Hermetic Receptacle		TV06 - Pg 36 Plug with Winged Coupling Nut			
Access	Lanyard - Pg 37 Release Plug		TV17 Flush Flange Jam Nut			
Tech						

Amphenol RoHS Compliant Platings

Alternative to Cadmium

The Defense Logistics Agency (DLA) has added the following cadmium alternative finishes to MIL-DTL-38999, Rev L (and other connector specs):

- Nickel Fluorocarbon Polymer
- Zinc-Nickel

DURMALON™

Amphenol's Answer to EU RoHS/ELV/Cadmium Free Restrictions. Commercial, Industrial & Military markets are rapidly moving away from restricted materials such as Cadmium (Cd) & Hexavalent Chromium (Cr(VI)). Both of these restricted materials are toxic and are known carcinogens. Amphenol is offering alternative finishes that comply with all customer requirements tied to these specifications.

Amphenol has qualified Durmalon, with internal part number coding "DT" finish, which meets or exceeds the 38999 designated class "T" finish, Nickel Fluorocarbon Polymer. Durmalon is also EU RoHS and Reach compliant and is Cadmium free, Lead free, and Hexavalent Chromium free.

Durmalon, like Olive-Drab Cadmium plating (Class W), meets 500 hours of dynamic salt spray, combined with 500 mating cycles and meets specified millivolt drop shell-to-shell conductivity. Durmalon has been proven to meet Potassium Formate-Deicer fluid testing performed by Boeing.

BLACK ZINC NICKEL

Black Zinc Nickel is a non-reflective, conductive black finish approved for 500 hrs salt spray making it an excellent choice for harsh environments. Black Zinc Nickel has been qualified by the DLA, with internal part number coding "DZ" finish, which meets or exceeds the 38999 designated class "Z" finish. Black Zinc Nickel is RoHS & Reach compliant.

DURMALON™
Alternative to Cadmium



- PCB
- HD
- Power
- Bulk
- Integral
- Plug
- Hermetic
- Speed
- Filter
- Access
- Tech

Requirements	Cadmium	Durmalon™	Black Zinc Nickel
Coupling Torque Post 500 hr. salt	■	■	■
Shell to Shell Conductivity <2.5 millivolts	■	■	■
Cycles of Durability 500 mates	■	■	■
Salt Spray Dynamic 500 hours	■	■	■
Temperature Rating 175° C	■	■	■
Non-Reflective	■	■	■
EU RoHS/ELV Compliant*		■	■
Non-Magnetic	■	■	■
De-icing Fluid**		■	■

* Meets EU RoHS/ELV maximum concentration values (MCV) of 1000 ppm (0.1% w/w) or (0.01% w/w) per homogenous material.

** Potassium Formate/Acetate based de-icing fluids.

Note: Specifications are subject to change without notice.

MIL-DTL-38999, Series III TV

Shell and Finish Data

- PCB
- HD
- Power
- Bulk
- Integral
- Plug
- Hermetic
- Speed
- Filter
- Access
- Tech

ALUMINUM & STEEL SHELL COMPONENTS NON-HERMETIC*				
Finish	Shell Material	Military	Amphenol Commercial	Salt Spray (hours)
Anodic Coating (Non-Conductive)	Aluminum	C	RX (005)	500
Electroless Nickel	Aluminum	F	RF	48
Olive Drab Cadmium Plate, Nickel Base	Aluminum	W	RW	500
Durmalon™ (Nickel PTFE)	Aluminum	T	DT	500
Black Zinc Nickel	Aluminum	Z	DZ	500
Electroless Nickel Space Grade	Aluminum	G	RF (453)	48
Black Electroless Nickel	Aluminum		DB	100
Olive Drab Cadmium, Nickel Base (1,000 hour)	Aluminum		DW	1,000
Marine Bronze	Aluminum Bronze		RB	500
Passivated Stainless Steel	Stainless Steel	K	RK	500
Passivated Stainless Steel (non-firewall)	Stainless Steel		RKN	500
Stainless Steel w. Nickel Plate	Stainless Steel	S	RS	500
Stainless Steel w. Nickel Plate (non-firewall)	Stainless Steel	L	RL	500
Electroless Nickel	Composite	M	RF	2,000
Olive Drab Cadmium Plate, Nickel Base	Composite	J	RW	2,000
Titanium, Passivated	Titanium		TR	500
Titanium, Conductive Plate	Titanium		TNR	500



MARINE BRONZE

ELECTROLESS NICKEL PLATED ALUMINUM

ZINC NICKEL PLATED ALUMINUM

DURMALON PLATED ALUMINUM

SELECT NON-STANDARD PLATING-USE RX SERVICE CLASS AND ADD SUFFIX BELOW

Finish	Shell Material	Amphenol Commercial	Salt Spray (hours)
Black Anodized (Non-Conductive)	Aluminum	(002)	500
Black Zinc Cobalt	Aluminum	(027)	200
Green Zinc Cobalt	Aluminum	(024)	200
Green Zinc Nickel	Aluminum	(037)	500

Amphenol Aerospace has an on-site plating facility and offers even more plating options if the above platings do not meet your needs. Please contact Amphenol factory for further details and requests

MIL-DTL-38999 Connectors with PCB Contacts



Amphenol has simplified the process of ordering a D38999 Series III connector with PCB tails with the new 38999 Plus catalog. Currently all Series III arrangements (mil-spec or proprietary) with size 23, 22D, 20, 16 or 12 gauge contacts (including mixed arrangements) are available for order using the following How To Order pages (contact AAO for size 8 and larger contacts).

PCB Connectors are available in a number of shell styles and PCB lengths. Contact our factory for customized solutions.

DOUBLE FLANGE RECEPTACLES



REDUCED FLANGE RECEPTACLES



PCB MIL-DTL-38999, Series III TV

How to Order (Commercial)

Complete steps 1-8 to create your part number

PCB

HD

Power

Bulk

Integral

Plug

Hermetic

Speed

Filter

Access

Tech

1.	2.	3.	4.	5.	6.	7.	8.
Connector Type	Shell Style	Service Class	Shell Size - Insert Arrangement	Contact Type	Alternate Position	PCB Length	Modifications
TV or PTV CTV or PCTV	07	RF	15-35	P	A	(P25)	(optional)

1. Connector Type

TV	Tri-Start, 175°C
TVS	Tri-Start, 200°C
TVP	Panel Mounted, 175°C
TVPS	Panel Mounted, 200°C
CTV	Composite Tri-Start, 175°
CTVP	Composite Back Panel Mounted 175° Receptacle
CTVPS	Composite Back Panel Mounted 200° Receptacle

2. Shell Style

00	Wall Mount Receptacle
02	Box Mount Receptacle
07	Jam Nut Receptacle



2. Shell Style Double Flange

40	Wall Mount Double Flange
47	Jam Nut Double Flange







2. Shell Style Reduced Flange

97	Reduced Flange Jam Nut
98	Reduced Flange Jam Nut with Standoff
48	Reduced Flange Jam Nut with Standoff

3. 175°C Service Class

RW	Corrosion resistant olive drab cadmium plated aluminum, 500 hour extended salt spray	
DT	Durmalon plated, alternative to cadmium. Corrosion resistant, 500 hour extended salt spray	
DZ	Black Zinc-Nickel alternative to cadmium. 500 hour salt spray, conductive	
DW	Corrosion resistant olive drab cadmium plated aluminum, 1,000 hour extended salt spray	

3. 200°C Service Class

RB	Marine Bronze - 500 hour salt spray	
RF	Electroless nickel plated aluminum, 48 hour salt spray	
RK	Corrosion resistant stainless steel, firewall capability, plus 500 hour salt spray resistance	
RKN	Corrosion resistant stainless steel, Nonfirewall capability, plus 500 hour salt spray resistance	
RL	Corrosion resistant steel, electro deposited nickel, 500 hour salt spray, non firewall	
RS	Nickel plated, corrosion resistant steel, firewall capability, 500 hour salt spray	
DS	AP-93 Tri-Nickel Alloy, Aluminum, 1000 Hr., 200°C, -65dB@100Hz*	

*Add P prefix for potted ex: PTV and PCTV

4. Shell Size - Insert Arrangement

Shell Size & Insert Arrangements are on pages 75-83. First number represents Shell Size, second number is the Insert Arrangement.

2. Shell Style Clinch Nuts

10	Wall Mount (Clinch Nuts)
11	Wall Mount (Metric Clinch Nuts)
12	Box Mount (Clinch Nuts)
13	Box Mount (Metric Clinch Nuts)
42	Wall Mount with integrated helicoils

5. Contact Type

P	Pin Contacts
S	Socket Contacts
H	Pin, 1500 cycle
J	Socket, 1500 cycle

6. Alternate Position

A, B, C, D, E omit for normal rotation parts. See page 84 for complete information

7. PCB CONTACT

Contact Type	PCB Stickout ± .040
(P15)	.150" w/ pins
(P25)	.250" w/ pins
(P35)	.350" w/ pins
(S15)	.150" w/ sockets
(S25)	.250" w/ sockets
(S35)	.350" w/ sockets

7. PCB CONTACT

With Alignment Disk

(P15AD)	.150" w/ pins
(P25AD)	.250" w/ pins
(P35AD)	.350" w/ pins
(S15AD)	.150" w/ sockets
(S25AD)	.250" w/ sockets
(S35AD)	.350" w/ sockets

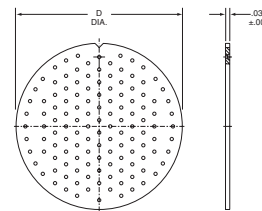

Shell Size	D Dia. ±.010
9	.234
11	.350
13	.500
15	.725
17	.750
19	.850
21	.953
23	1.147
25	1.250

Pre-Tin Options

Add "T" to end of suffix for Pre-tinned PC tails
Ex: (P15T), (S25ADT)

Note: Stick out is measured from the end of the connector shell to end of the contact

Wall Mounting Receptacles

Back Panel Mounting TVP00, TVPS00, CTVP00, CTVPS00

PART NUMBER BUILDER Page 10

ONLINE CONFIGURATOR www.amphenol-aerospace.com

ALUMINUM
TVPS00RF
TVP00RW
TVP00DT
TVP00DZ
TVPS00RB
TVPS00DS
TVP00DW

STAINLESS STEEL
TVPS00RK
TVPS00RKN
TVPS00RS
TVPS00RL

COMPOSITE
CTVP00RW
CTVP00RF
CTVP00DZ
CTVP00DT

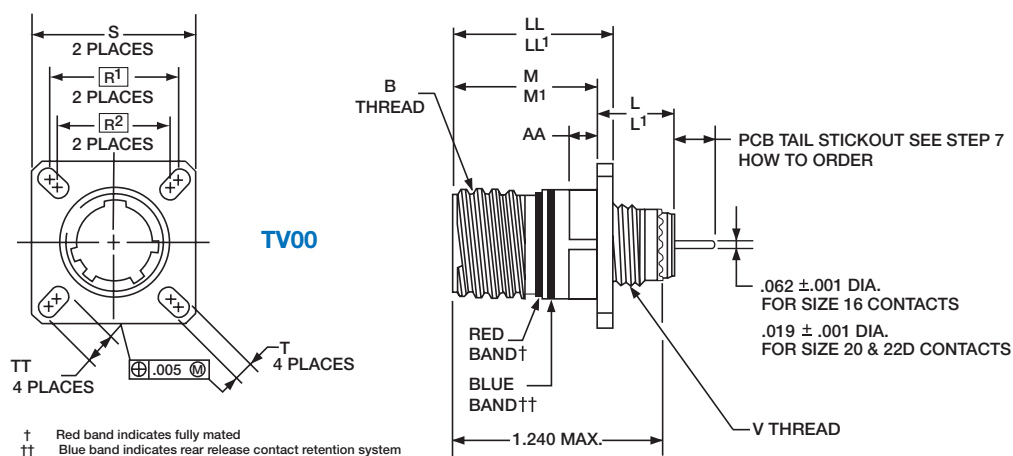

† Red band indicates fully mated
†† Blue band indicates rear release contact retention system

Shell Size	B Thread Class 2A (Plated) 0.1P-0.3L-TS	L Max. (TV)	L' Max. (CTV)	M +.000 - .005 (TV)	M' +.000 - .005 (CTV)	R1	R2	S Max. (TV)	S Max. (CTV)	T +.008 - .006	V Thread Metric	AA Max. Panel Thickness	LL +.006 - .000 (TV)	LL' ±.005 (CTV)	TT +.008 - .006
9	.6250	.469	.514	.820	.773	.719	.594	.948	.942	.128	M12X1-6g	.234	.905	.908	.216
11	.7500	.469	.514	.820	.773	.812	.719	1.043	1.037	.128	M15X1-6g	.234	.905	.908	.194
13	.8750	.469	.514	.820	.773	.906	.812	1.137	1.131	.128	M18X1-6g	.234	.905	.908	.194
15	1.0000	.469	.514	.820	.773	.969	.906	1.232	1.226	.128	M22X1-6g	.234	.905	.908	.173
17	1.1875	.469	.514	.820	.773	1.062	.969	1.323	1.316	.128	M25X1-6g	.234	.905	.908	.194
19	1.2500	.469	.514	.820	.773	1.156	1.062	1.449	1.442	.128	M28X1-6g	.234	.905	.908	.194
21	1.3750	.500	.545	.790	.741	1.250	1.156	1.575	1.568	.128	M31X1-6g	.204	.905	.904	.194
23	1.5000	.500	.545	.790	.741	1.375	1.250	1.701	1.694	.154	M34X1-6g	.204	.905	.904	.242
25	1.6250	.500	.545	.790	.741	1.500	1.375	1.823	1.816	.154	M37X1-6g	.204	.905	.904	.242

All dimensions for reference only.

Most common options are shown; other options are available.

□ Designates true position dimensioning

Wall Mounting Receptacles with Clinch Nuts

Back Panel Mounting TVP10, TVPS10, CTVP10 & CTVPS10, TVP11, TVPS11, CTVP11, CTVPS11

PART NUMBER BUILDER Page 10

ONLINE CONFIGURATOR www.amphenol-aerospace.com

PCB

HD

Power

Bulk

Integral

Plug

Hermetic

Speed

Filter

Access

Tech

ALUMINUM

TVP10RW TVP11RW
 TVP10DT TVP11DT
 TVP10DZ TVP11DZ
 TVPS10RF TVPS11RF
 TVPS10RB TVPS11RB
 TVPS10DS TVPS11DS
 TVP10DW TVP11DW

STAINLESS STEEL

TVPS10RK TVPS11RK
 TVPS10RKN TVPS11RKN
 TVPS10RS TVPS11RS
 TVPS10RL TVPS11RL

COMPOSITE

CTVPS10RF CTVPS11RF
 CTVP10RW CTVP11RW
 CTVP10DZ CTVP11DZ
 CTVP10DT CTVP11DT

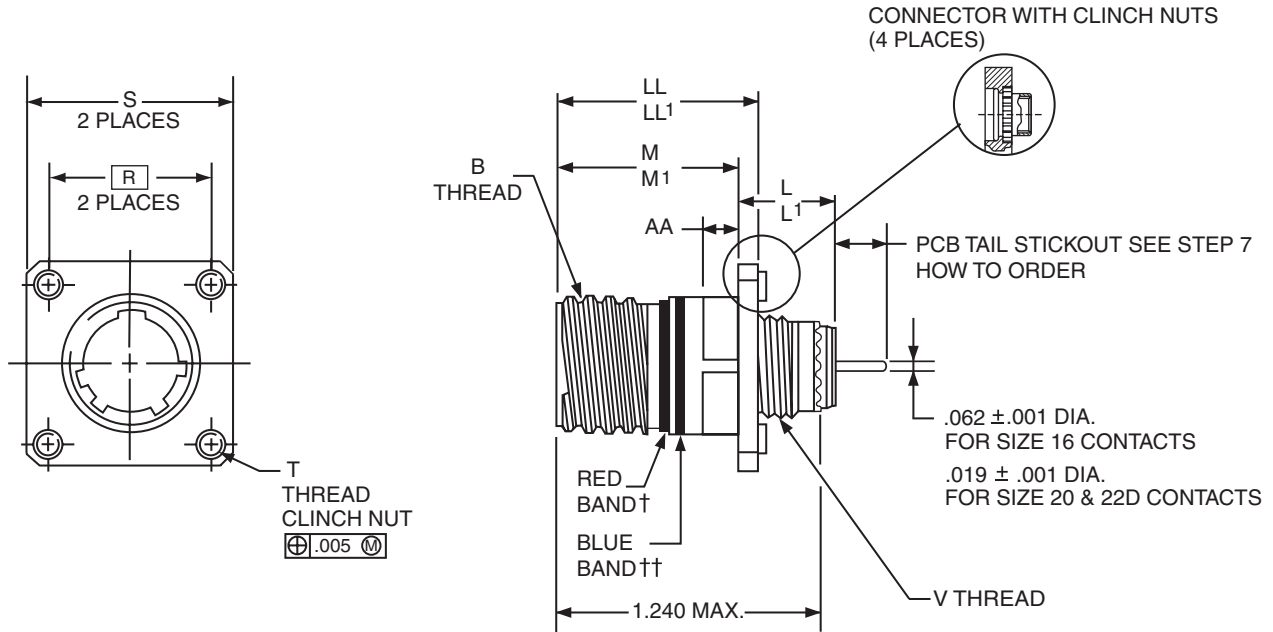

Shell Size	B Thread Class 2A (Plated) 0.1P-0.3L-TS	L Max. (TV)	L' Max. (CTV)	M +.000 - .005 (TV)	M' +.000 - .005 (CTV)	R	S Max. (TV)	S Max. (CTV)	T Thread	V Thread Metric	AA Max. Panel Thickness	LL +.006 - .000 (TV)	LL' ±.005 (CTV)
9	.6250	.469	.514	.820	.773	.719	1.094	.942	.112-40UNC-3B	M12X1-6g	.234	.905	.908
11	.7500	.469	.514	.820	.773	.812	1.187	1.037	.112-40UNC-3B	M15X1-6g	.234	.905	.908
13	.8750	.469	.514	.820	.773	.906	1.281	1.131	.112-40UNC-3B	M18X1-6g	.234	.905	.908
15	1.0000	.469	.514	.820	.773	.969	1.344	1.226	.112-40UNC-3B	M22X1-6g	.234	.905	.908
17	1.1875	.469	.514	.820	.773	1.062	1.437	1.316	.112-40UNC-3B	M25X1-6g	.234	.905	.908
19	1.2500	.469	.514	.820	.773	1.156	1.531	1.442	.112-40UNC-3B	M28X1-6g	.234	.905	.908
21	1.3750	.500	.545	.790	.741	1.250	1.625	1.568	.112-40UNC-3B	M31X1-6g	.204	.905	.904
23	1.5000	.500	.545	.790	.741	1.375	1.750	1.694	.138-32UNC-3B	M34X1-6g	.204	.905	.904
25	1.6250	.500	.545	.790	.741	1.500	1.875	1.816	.138-32UNC-3B	M37X1-6g	.204	.905	.904

All dimensions for reference only.

Consult Amphenol for more information on ordering connectors with clinch nuts.

Most common options are shown; other options are available.

□ Designates true position dimensioning

† Red band indicates fully mated

†† Blue band indicates rear release contact retention system

Wall Mounting Double Flange Receptacles

TVP40, TVPS40, CTVP40 & CTVPS40

PART NUMBER BUILDER Page 10

ONLINE CONFIGURATOR www.amphenol-aerospace.com

ALUMINUM
TVPS40RF
TVP40RW
TVP40DT
TVP40DZ
TVPS40RB
TVPS40DS
TVP40DW

STAINLESS STEEL
TVPS40RK
TVPS40RKN
TVPS40RS
TVPS40RL

COMPOSITE
CTVPS40RF
CTVP40RW
CTVP40DZ
CTVP40DT

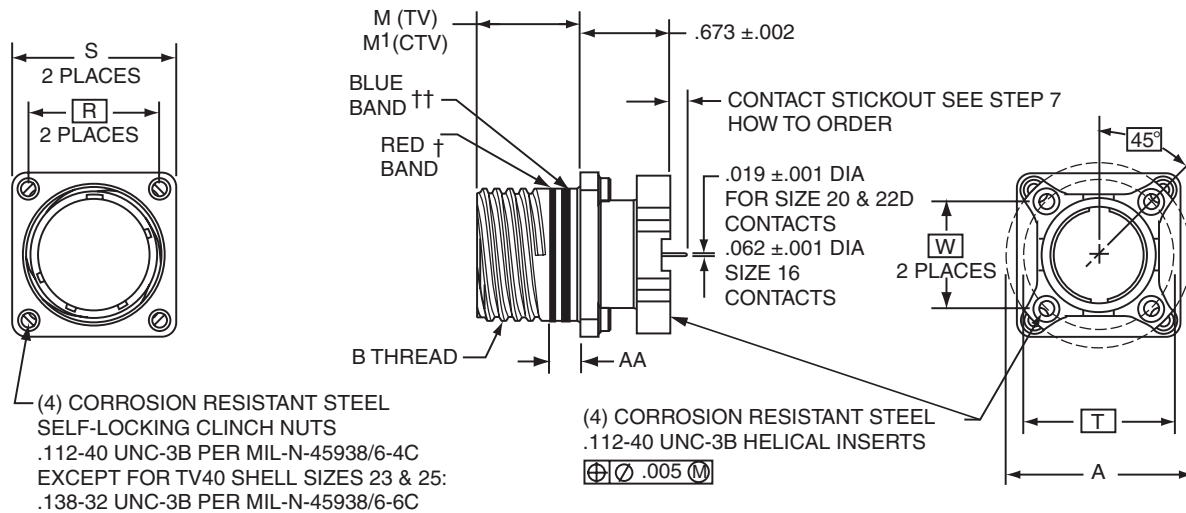

(4) CORROSION RESISTANT STEEL SELF-LOCKING CLINCH NUTS
.112-40 UNC-3B PER MIL-N-45938/6-4C
EXCEPT FOR TV40 SHELL SIZES 23 & 25:
.138-32 UNC-3B PER MIL-N-45938/6-6C

(4) CORROSION RESISTANT STEEL
.112-40 UNC-3B HELICAL INSERTS
⊕⊖ .005 M

⊕⊖ .005 M

Shell Size	MS Shell Size Code (For Ref.)	A Dia. ±.005 (TV)	A Dia. ±.005 (CTV)	B Thread Class 2A (Plated) 0.1P-0.3L-TS	M +.000 - .005	M1 ±.003 (CTV)	R Panel Mount (CTV)	R Panel Mount (TV)	S Max. (TV)	S Max. (CTV)	AA Max. Panel Thickness	PCB Mounting Dimensions	
												T Dia. (TV) TP	W (CTV) TP
9	A	NA	NA	.6250	.820	NA	NA	.686	1.124	NA	.234	NA	NA
11	B	1.062	1.148	.7500	.820	.770	.812	.766	1.217	1.043	.234	.850	.601
13	C	1.250	1.250	.8750	.820	.770	.906	.859	1.311	1.138	.234	.994	.703
15	D	1.375	1.375	1.0000	.820	.770	.969	.938	1.371	1.232	.234	1.119	.791
17	E	1.500	1.500	1.1875	.820	.770	1.062	1.016	1.467	1.323	.234	1.237	.875
19	F	1.625	1.625	1.2500	.820	.770	1.156	1.110	1.588	1.449	.234	1.379	.975
21	G	1.750	1.750	1.3750	.820	.738	1.250	1.206	1.714	1.573	.204	1.489	1.053
23	H	1.875	1.875	1.5000	.820	.738	1.375	1.312	1.840	1.701	.204	1.619	1.195
25	J	2.000	2.000	1.6250	.820	.738	1.500	1.438	1.962	1.823	.204	1.744	1.233

All dimensions for reference only.

† Red band indicates fully mated

†† Blue band indicates rear release contact retention system

Box Mounting Receptacles

TVP02 ,TVPS02, CTVP02 & CTVPS02

PCB HD Power Bulk Integral Plug Hermetic Speed Filter Access Tech

PART NUMBER BUILDER Page 10
 ONLINE CONFIGURATOR www.amphenol-aerospace.com

ALUMINUM	STAINLESS STEEL	COMPOSITE
TVPS02RF	TVPS02RK	CTVPS02RF
TVP02RW	TVPS02RKN	CTVP02RW
TVP02DT	TVPS02RS	CTVP02DZ
TVP02DZ	TVPS02RL	CTVP02DT
TVPS02RB		
TVPS02DS		
TVP02DW		

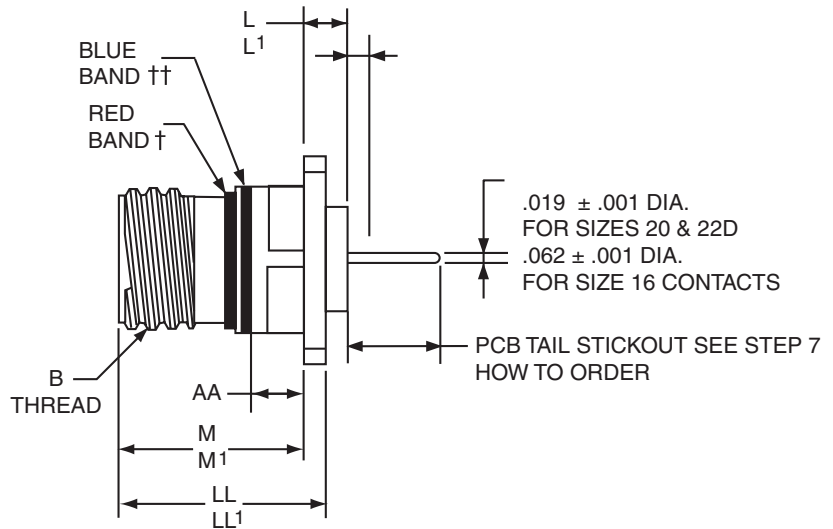
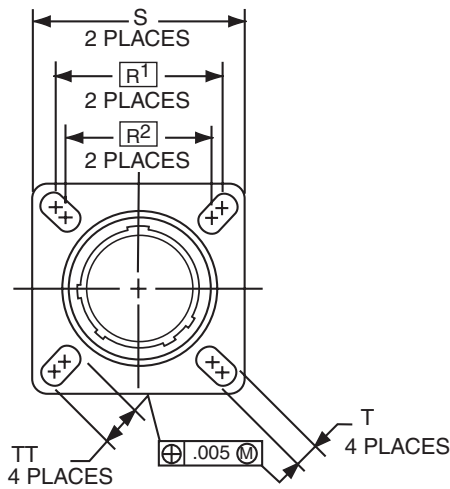

Shell Size	B Thread Class 2A (Plated) 0.1P-0.3L-TS	L Max. (TV)	L' Max. (CTV)	M +.000 - .005 (TV)	M' +.000 - .005 (CTV)	R1	R2	S Max. (TV)	S Max. (CTV)	T +.008 - .006	AA Max. Panel Thickness	LL +.006 - .000 (TV)	LL' ±.005 (CTV)	TT ±.008
9	.6250	.205	.250	.820	.773	.719	.594	.938	.942	.128	.234	.905	.908	.216
11	.7500	.205	.250	.820	.773	.812	.719	1.031	1.037	.128	.234	.905	.908	.194
13	.8750	.205	.250	.820	.773	.906	.812	1.125	1.131	.128	.234	.905	.908	.194
15	1.0000	.205	.250	.820	.773	.969	.906	1.219	1.226	.128	.234	.905	.908	.173
17	1.1875	.205	.250	.820	.773	1.062	.969	1.312	1.316	.128	.234	.905	.908	.194
19	1.2500	.205	.250	.820	.773	1.156	1.062	1.438	1.442	.128	.234	.905	.908	.194
21	1.3750	.235	.280	.790	.741	1.250	1.156	1.562	1.568	.128	.204	.905	.904	.194
23	1.5000	.235	.280	.790	.741	1.375	1.250	1.688	1.694	.154	.204	.905	.904	.242
25	1.6250	.235	.280	.790	.741	1.500	1.375	1.812	1.816	.154	.204	.905	.904	.242

All dimensions for reference only.

Most common options are shown; other options are available.

□ Designates true position dimensioning

† Red band indicates fully mated

†† Blue band indicates rear release contact retention system

Box Mounting Receptacles with Clinch Nuts

TVP12, TVPS12, CTVP12, CTVPS12, TVP13, CTVP13 & CTVPS13

PART NUMBER BUILDER Page 10

ONLINE CONFIGURATOR www.amphenol-aerospace.com

ALUMINUM

TVPS12RF TVPS13RF
TVP12RW TVP13RW
TVP12DT TVP13DT
TVP12DZ TVP13DZ
TVPS12RB TVPS13RB
TVPS12DS TVPS13DS
TVP12DW TVP13DW

STAINLESS STEEL

TVPS12RK TVPS13RK
TVPS12RKN TVPS13RKN
TVPS12RS TVPS13RS
TVPS12RL TVPS13RL

COMPOSITE

CTVP12RW CTVP13RW
CTVPS12RF CTVPS13RF
CTVP12DZ CTVP13DZ
CTVP12DT CTVP13DT

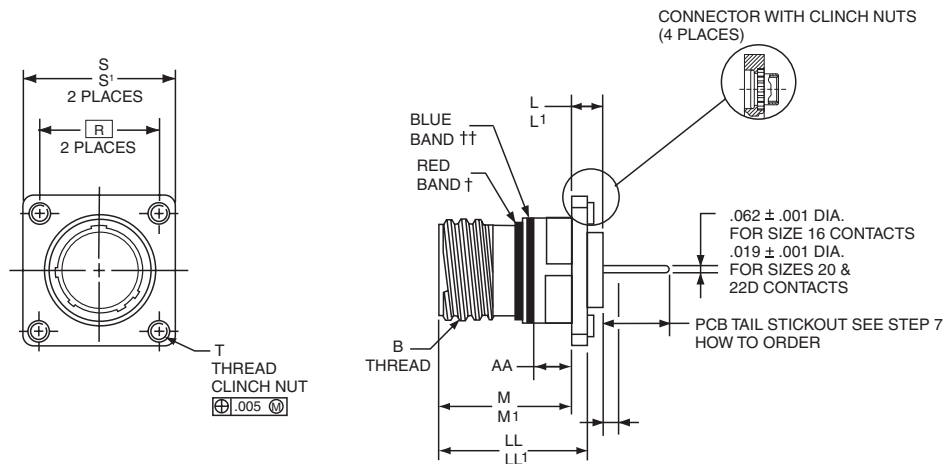

Shell Size	B Thread Class 2A (Plated) 0.1P-0.3L-TS	L Max. (TV)	L' Max. (CTV)	M +.000 - .005 (TV)	M' +.000 - .005 (CTV)	R	S Max. (TV)	S' Max. (CTV)	T Thread	AA Max. Panel Thickness	LL +.006 - .000 (TV)	LL' +.006 - .000 (CTV)
9	.6250	.205	.250	.820	.773	.719	1.031	.948	.112-40UNC-3B	.234	.905	.908
11	.7500	.205	.250	.820	.773	.812	1.125	1.043	.112-40UNC-3B	.234	.905	.908
13	.8750	.205	.250	.820	.773	.906	1.172	1.137	.112-40UNC-3B	.234	.905	.908
15	1.0000	.205	.250	.820	.773	.969	1.281	1.232	.112-40UNC-3B	.234	.905	.908
17	1.1875	.205	.250	.820	.773	1.062	1.375	1.322	.112-40UNC-3B	.234	.905	.908
19	1.2500	.205	.250	.820	.773	1.156	1.469	1.448	.112-40UNC-3B	.234	.905	.908
21	1.3750	.235	.280	.790	.741	1.250	1.625	1.574	.112-40UNC-3B	.204	.905	.904
23	1.5000	.235	.280	.790	.741	1.375	1.750	1.700	.112-40UNC-3B	.204	.905	.904
25	1.6250	.235	.280	.790	.741	1.500	1.875	1.822	.112-40UNC-3B	.204	.905	.904

All dimensions for reference only.

Most common options are shown; other options are available.

□ Designates true position dimensioning

† Red band indicates fully mated

†† Blue band indicates rear release contact retention system

Jam Nut Receptacles

TV07, TVS07, CTV07 & CTVS07

PART NUMBER BUILDER Page 10
ONLINE CONFIGURATOR www.amphenol-aerospace.com

PCB

HD

Power

Bulk

Integral

Plug

Hermetic

Speed

Filter

Access

Tech

ALUMINUM	STAINLESS STEEL	COMPOSITE
TVS07RF	TVS07RK	CTV07RW
TV07RW	TVS07RKN	CTVS07RF
TV07DT	TVS07RS	CTV07DZ
TV07DZ	TVS07RL	CTV07DT
TVS07RB		
TVS07DS		
TV07DW		

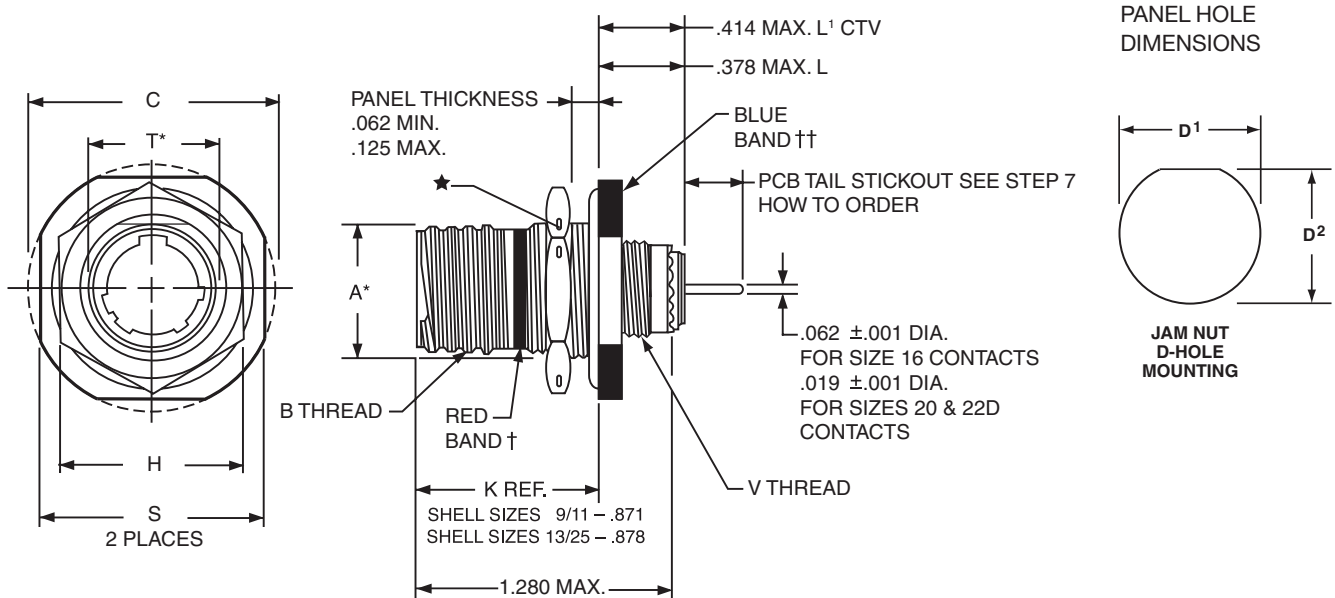

Shell Size	A* +.000 -.010	B Thread Class 2A (Plated) 0.1P-0.3L-TS	C Max.	D ¹ +.010 -.000	D ² +.010 -.000	H Hex +.017 -.016	L MAX (TV)	L ¹ MAX (CTV)	S ±.010	T +.010 -.000	V Thread Metric
9	.669	.6250	1.199	.700	.670	.875	.372	.414	1.062	.697	M12X1-6g
11	.769	.7500	1.386	.825	.770	1.000	.372	.414	1.250	.822	M15X1-6g
13	.955	.8750	1.511	1.010	.955	1.188	.365	.407	1.375	1.007	M18X1-6g
15	1.084	1.0000	1.636	1.135	1.085	1.312	.365	.407	1.500	1.134	M22X1-6g
17	1.208	1.1875	1.761	1.260	1.210	1.438	.365	.407	1.625	1.259	M25X1-6g
19	1.333	1.2500	1.949	1.385	1.335	1.562	.365	.407	1.812	1.384	M28X1-6g
21	1.459	1.3750	2.073	1.510	1.460	1.688	.365	.407	1.938	1.507	M31X1-6g
23	1.575	1.5000	2.199	1.635	1.585	1.812	.365	.407	2.062	1.634	M34X1-6g
25	1.709	1.6250	2.323	1.760	1.710	2.000	.365	.407	2.188	1.759	M37X1-6g

All dimensions for reference only.
Most common options are shown;
other options are available.

- † Red band indicates fully mated
- †† Blue band indicates rear release contact retention system
- * .059 dia. min. 3 lockwire holes or formed lockwire hole design (6 holes).
- **"D" shaped mounting hole dimensions

Jam Nut, Double Flange Receptacles

TV47 & TVS47

PART NUMBER BUILDER Page 10
ONLINE CONFIGURATOR www.amphenol-aerospace.com

ALUMINUM	STAINLESS STEEL
TVS47RF	TVS47RK
TV47RW	TVS47RKN
TV47DT	TVS47RS
TV47DZ	TVS47RL
TVS47RB	
TVS47DB	
TV47DW	

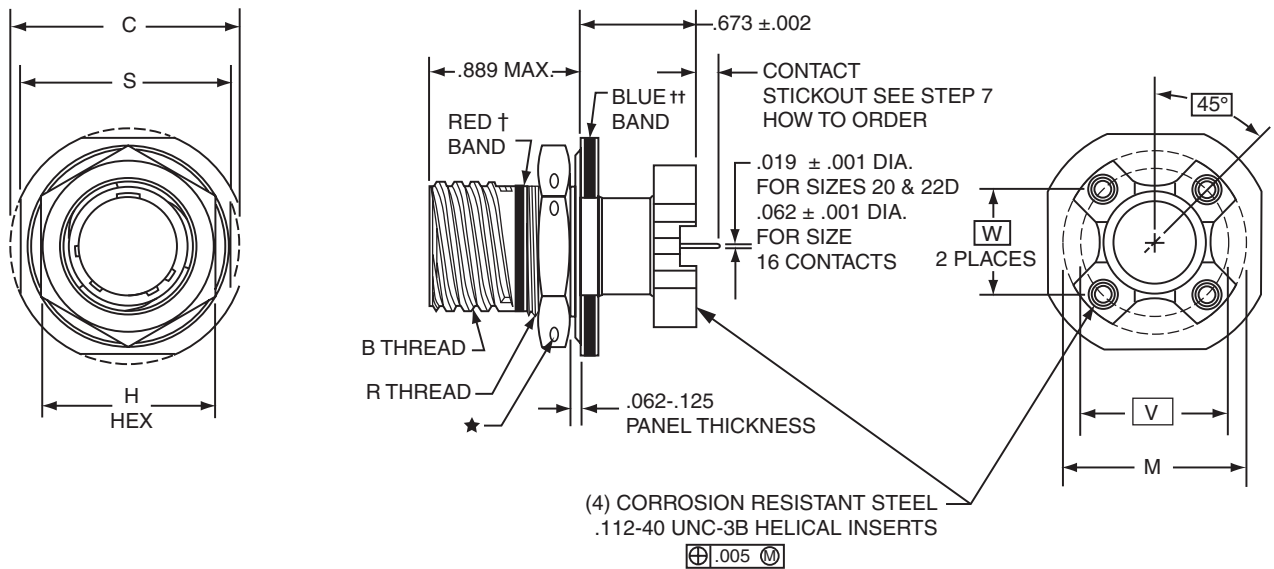
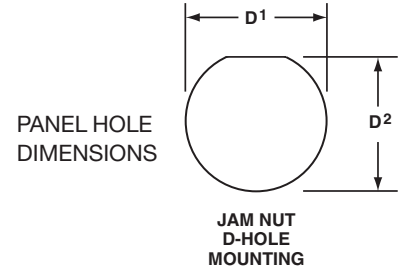

Shell Size	MS Shell Size Code (For Ref.)	B Thread Class 2A 0.1P-0.3L-TS (Plated)	C ±.005 (Jam Nut Flange Dia.)	D' +.010 -0.000	D ² +.000 -0.010	H Hex +.017 -0.016	M Dia. ±.005 (TV)	M Dia. ±.005 (CTV)	R Thread Metric (Plated)	S +.011 -0.010	PCB Mounting Dimensions	
											V Dia. (TV) TP	W (CTV) TP
9	A	.6250	1.188	.700	.670	.875	1.062	1.016	M17X1-6g0.100R	1.062	.753	.532
11	B	.7500	1.375	.825	.770	1.000	1.062	1.148	M20X1-6g0.100R	1.250	.850	.601
13	C	.8750	1.500	1.010	.955	1.188	1.250	1.250	M25X1-6g0.100R	1.375	.994	.703
15	D	1.0000	1.625	1.135	1.085	1.312	1.375	1.375	M28X1-6g0.100R	1.500	1.119	.791
17	E	1.1875	1.750	1.260	1.210	1.438	1.500	1.500	M32X1-6g0.100R	1.625	1.237	.875
19	F	1.2500	1.937	1.385	1.335	1.562	1.625	1.625	M35X1-6g0.100R	1.812	1.379	.975
21	G	1.3750	2.062	1.510	1.460	1.688	1.750	1.750	M38X1-6g0.100R	1.937	1.489	1.053
23	H	1.5000	2.188	1.635	1.585	1.812	1.875	1.875	M41X1-6g0.100R	2.062	1.644	1.145
25	J	1.6250	2.312	1.760	1.710	2.000	2.000	2.000	M44X1-6g0.100R	2.188	1.744	1.233

All dimensions for reference only.

† Red band indicates fully mated

†† Blue band indicates rear release contact retention system.

* .059 dia. min. (1.5 dia. min.) 3 lockwire holes or formed lockwire hole design (6 holes).

Reduced Flange Jam Nut Receptacles

TV97, TVS97, TV98, TVS98

PART NUMBER BUILDER Page 10
 ONLINE CONFIGURATOR www.amphenol-aerospace.com

PCB

HD

Power

Bulk

Integral

Plug

Hermetic

Speed

Filter

Access

Tech

ALUMINUM		STAINLESS STEEL
TVS97RF	TVS98RF	TVPS97RK
TV97RW	TV98RW	TVPS97RKN
TV97DT	TV98DT	TVPS97RS
TV97DZ	TV98DZ	TVPS97RL
TVS97RB	TVS98RB	
TVS97DB	TVS98DB	
TV97DW	TV98DW	

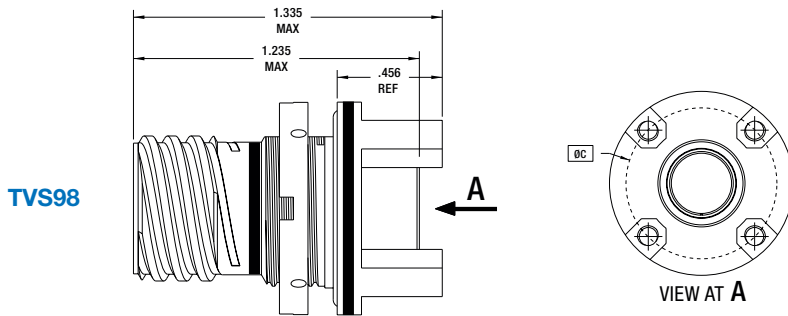
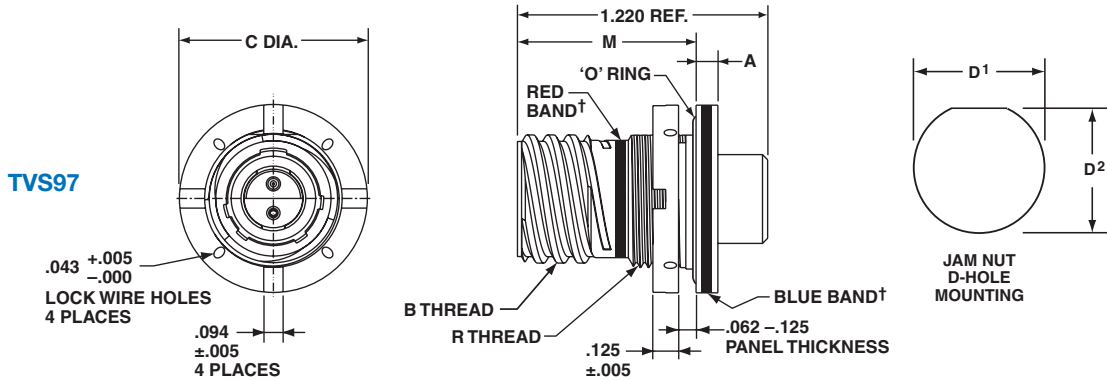

Shell Size	Footprint Reduction	Ø B Max	Ø GG Max	Ø C MAX
9	42%	.443	.915	.744
11	46%	.567	1.042	.862
13	37%	.680	1.240	1.020
15	36%	.811	1.357	1.141
17	21%	.936	1.630	1.385
19	21%	1.042	1.816	1.531
21	21%	1.167	1.942	1.656
23	21%	1.292	2.067	1.782
25	22%	1.417	2.190	1.910

Shell Size	MS Shell Size Code	B Thread Class 2A 0.1P-0.3L-TS (Plated)	A +.010 / -.005	C Dia. Max.	D1 +.010 / -.000	D2 +.000 / -.010	M	R Thread (Plated) 9-7543
9	A	.6250	.104	.915	.693	.657	.871	M17X1-6g
11	B	.7500	.104	1.042	.825	.770	.871	M20X1-6g
13	C	.8750	.104	1.240	1.010	.955	.878	M25X1-6g
15	D	1.0000	.104	1.357	1.135	1.085	.878	M28X1-6g
17	E	1.1875	.104	1.630	1.260	1.210	.878	M32X1-6g
19	F	1.2500	.135	1.816	1.385	1.335	.878	M35X1-6g
21	G	1.3750	.135	1.942	1.510	1.460	.878	M38X1-6g
23	H	1.5000	.135	2.067	1.635	1.585	.878	M41X1-6g
25	J	1.6250	.135	2.190	1.760	1.710	.878	M44X1-6g

38999 PCB Connector with Ground Pins



- Available in box mount and jam nut style shells
- Intermateable with any MIL-DTL-38999 Series III plugs and Accessories
- Allows for PCB to be grounded directly to board
- Multiple ground pin positions available
- Available in aluminum with all Amphenol standard plating options

Example: TV07DZ-15-35P(P25B)

Only available is shell style 02 and 07. See page 10 for complete How to Order options.

1. Connector Type	2. Shell Style	3. Service Class	4. Shell Size - Insert Arrangement	5. Contact Type	6. Alternate Position	7. PCB Length	8. Pin Orientation
TV or PTV (Potted Version)	07	RF	15-35	P	A	(P25)	B

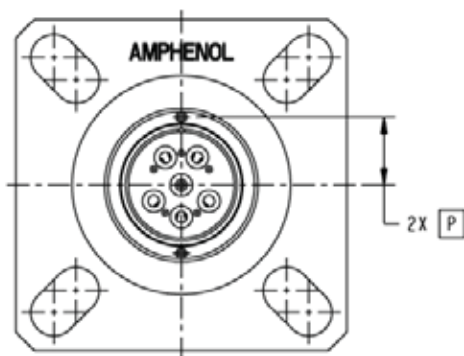

Shell Size	P
9	.194
11	.257
13	.315
15	.378
17	.441
19	.494
21	.556
23	.619
25	.681

Ground Pin Orientation Table		
# of Pins	Location	Suffix
1	Upper	U
	Lower	L
2	Both	B

High Density Interconnects



HD38999
High Density

The HD38999 family of connectors has 30% more contact density than the highest density Mil Spec 38999 connectors of comparable size. This series of connectors was designed to utilize Military Specified 38999 components with the exception of the contacts and inserts arrangement. Utilizing existing qualified M39029 size 23 contacts and 38999 insert materials, these connectors are essentially a drop-in replacement for a standard 38999 connector.

HD38999 is tested and meets the requirements of MIL-DTL-38999 Series III. If you need a customized version please contact us with your requirement.

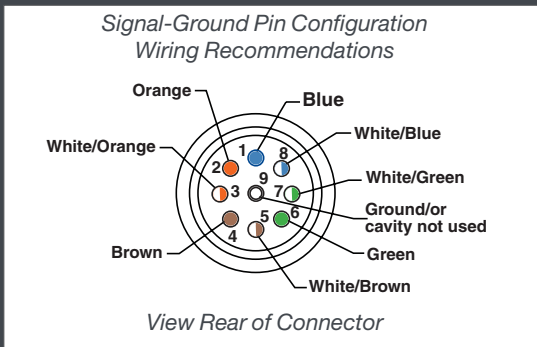

HD38999 for Gigabit Ethernet Applications

The HD38999 is available for high speed (Gigabit Ethernet) data transmission in the size 9-9 insert pattern. Data transmission performance of this connector insert:

- 10 Base T, 100 Base TX, and 1000 Base T networks using Cat 5e per TIA/EIA568B and Class D per ISO/IEC 11801. (Test report available - consult Amphenol Aerospace for more information)

Filtered HD38999 Connectors - for EMI/EMP Protection

High density patterns are available in filter 38999 connectors - consult Amphenol Aerospace for ordering.

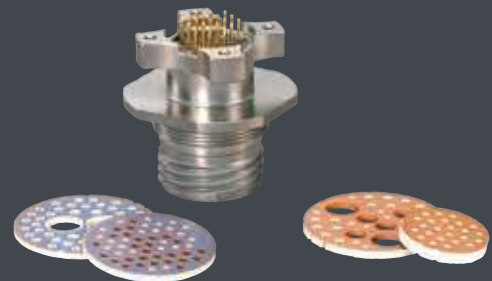

High Density Interconnects

How to Order

1.	2.	3.	4.	5.	6.	7.
Connector Type	Shell Style	Service Class	Shell Size - Insert Arrangement	Contact Type	Alternate Positions	PCB Optional
TV or PTV (Potted version)	07	RW	23-151	P	B	(P25)

P (prefix for Potted)

1. Connector Type	
TV	Tri-Start Series Connector
TVP	Panel Mounted Receptacle
CTV	Composite Tri-Start Series
CTVP	Panel Mounted Composite

*Add P prefix for potted ex: PTV











4. Shell Size - Insert Arrangement	
Shell Size	Insert Arrangement Number
9-	9
11-	19
13-	32
15-	55
17-	73
19-	88
21-	121
23-	151
25-	187

Shell Sizes are MIL-DTL-38999, Series III.

5. Contact Type	
P	500 Cycle Pin Contacts
S	500 Cycle Socket Contacts
H	1500 Cycle Pin Contacts
J	1500 Cycle Socket Contacts

2. Shell Style	
00	Wall Mount Receptacle
40	Wall Mount Double Flange Receptacle
10	Wall Mount (Clinch Nuts)
80	Wall Mount with Integral Backshell
02	Box Mount Receptacle
12	Box Mount (Clinch Nuts)
01	Line Receptacle
07	Jam Nut Receptacle
47	Jam Nut Double Flange Receptacle
87	Jam Nut with Integral Backshell
97	Reduced Flange Jam Nut Receptacle
98	Reduced Flange Jam Nut with Standoffs
06	Straight Plug
96	Straight Plug with Integral Backshell (not available in composite)
76	Plug with Integral Strain Relief

6. Alternate Position	
A, B, C, D, E and omit for normal Rotation. See page 84 for complete information	

3. Service Class (ALL 175°C)		
RW	Corrosion resistant olive drab cadmium plated aluminum, 500 hour extended salt spray	
DT	Durmalon plated, alternative to cadmium. Corrosion resistant, 500 hour extended salt spray	
DZ	Black Zinc-Nickel alternative to cadmium. 500 hour salt spray, conductive	
DW	Corrosion resistant olive drab cadmium plated aluminum, 1,000 hour extended salt spray	
RB	Marine Bronze - 500 hour salt spray	
RF	Electroless nickel plated aluminum, 48 hour salt spray	
RK	Corrosion resistant stainless steel, fire-wall capability, plus 500 hour salt spray resistance	
RKN	Corrosion resistant stainless steel, Nonfirewall capability, plus 500 hour salt spray resistance	
RL	Corrosion resistant steel, electro deposited nickel, 500 hour salt spray, non firewall	
RS	(Non-hermetic connectors), Nickel plated, corrosion resistant steel, firewall capability, 500 hour salt spray	
DB	Black Electroless Nickel, 100 hour salt spray	
DS	AP-93 Tri-Nickel Alloy, Aluminum, 1000 Hr., 200°C, -65dB@100Hz*	

7. PCB Contact Options				
Pin Contacts	Pin Contacts with Alignment Disc*	Socket Contacts	Socket Contacts with Alignment Disc	PCB tail stickout +/- .040 inch
P1	P1AD	S1	S1AD	.100*
P15	P15AD	S15	S15AD	.150*
P2	P2AD	S2	S2AD	.200*
P25	P25AD	S25	S25AD	.250*
P3	P3AD	S3	S3AD	.300*
P35	P35AD	S35	S35AD	.350*

Pre-Tin Options

Add "T" to end of suffix for Pre-tinned PC tails
Ex: (P15T), (S25ADT)

- PCB
- HD
- Power
- Bulk
- Integral
- Plug
- Hermetic
- Speed
- Filter
- Access
- Tech

Tri-Power with RADSOK® Technology



Amphenol has combined the reliability of D38999 connectors with the high-current RADSOK® contact design.

The Amphenol Power Connectors incorporate the proven design of the MIL-DTL-38999 Series III Tri-Start connectors with the evolving technology of the High Power RADSOK® contacts. This newly designed product enables customers to choose contacts ranging from 70 to 120 amps (240 to 620 amps per connector) allowing more power in a smaller connector.

Using standard shell sizes for 38999 connectors will allow the Power Connectors to mate to existing mounting holes without changing the customer's original design. In addition, Amphenol offers oversized 38999-style shells which are able to provide more power and amperage, while maintaining the proven, trusted MIL-DTL-38999 style design.

Low Contact Resistance:

The large interface area between the socket lamella and pin surface result in very low contact resistance, enabling the RADSOK® contacts' high current ratings compared to traditional power contact designs.

High Mating Cycle Durability:

Even with continuous exposure to harsh environmental abuse (salt, sand, and high humidity), RADSOK® contacts have been tested to maintain low contact resistance beyond 10,000 mating cycles.



High Reliability:

Unique RADSOK® design and construction technology create an electrical contact interface that exceeds typical interconnect requirements. Applications in aerospace, medical, industrial, automotive, mining, offshore, and other harsh environments depend on high reliability of the Amphenol RADSOK® technology.

Low Contact Engagement/ Separation Forces:

The hyperbolic lamella socket contact construction distributes normal forces over a high percentage of the mating pin surface. This creates a smooth, even engagement effort.

Tri-Power with Radsok Contacts

How to Order



1.	2.	3.	4.	5.	6.	7.
Connector Type	Shell Style	Service Class	Shell Size	Insert Arrangement	Contact Type	Alternate Positions
MP	00	RF	21	AH	P	B

1. Connector Type	
MP	Tri-Power

2. Shell Style	
00	Wall Mount Receptacle
06	Plug
07	Jam Nut Receptacle

3. Service Class	
RS	Nickel plated, corrosion resistant steel, firewall capability, 500 hour salt spray, 200°C
RF	Electroless nickel plated aluminum 48 hour salt spray, 200°C
RW	Corrosion resistant olive drab cadmium plated aluminum, 500 hour extended salt spray, 175°C
DT	Durmalon: Gray non-reflective finish, RoHS® compliant cad & Hexavalent Chromium free. 500 hours extended salt spray, 175°C
DZ	Black Zinc-Nickel alternative to cadmium. Corrosion resistant, 500 hour salt spray, conductive, 175°C

4. Shell Size	
21	MIL Shell Size G
23*	MIL Shell Size H
25	MIL Shell Size J
25L	-Proprietary
33	-Proprietary

5. Insert Arrangement	
See drawings to the right	

* Consult Amphenol for availability

6. Contact Type	
P	Pin Contacts
S	Socket Contacts

7. Alternate Position	
A, B, C, D, E omit for normal rotation parts. See page 84 for complete information	

* For Special termination methods such as threaded or solder cup, contact factory

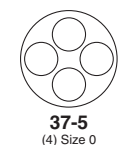
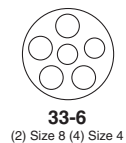
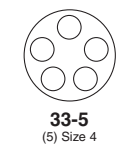

RADSOK Contact Derating Chart

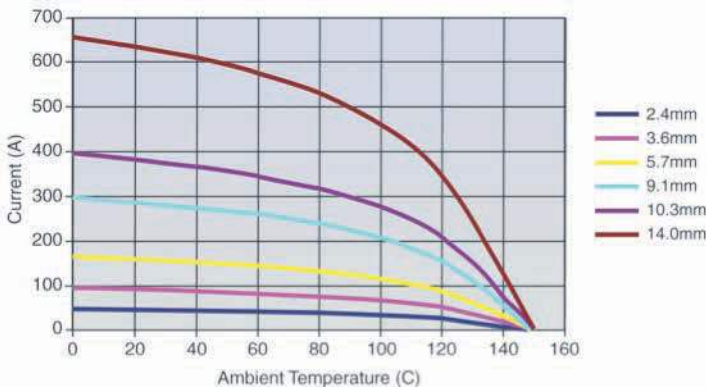

Standard Contacts	
Size	Amps
8	46
4	80
0	150

RADSOK Contacts	
Size	Amps
8	70
4	120
0	250



- PCB
- HD
- Power
- Bulk
- Integral
- Plug
- Hermetic
- Speed
- Filter
- Access
- Tech

Bulkhead Feed-Throughs, Connector Savers & Plug Adapters



Bulkhead Feed-Through Connectors remove the need for discrete wire termination when assembling the connector

Amphenol Aerospace's Bulkhead Feed-Through connectors are double-ended receptacles with feed through contacts that mate to standard MIL-DTL-D38999 plugs. Available in multiple shell and contact gender configurations, they are designed to meet applicable requirements for 38999 series III and allow for usage in new applications where standard connectors won't suffice.

Connector Savers:

Amphenol's Connector Savers protect connectors subjected to repeated mating cycles and prevent costly repairs associated with replacement of connectors and/or cables. These connectors can also be used when mating plugs to alternate plated receptacle in efforts to avoid corrosion. Fully compatible with standard MIL-DTL-38999 connectors and protection caps.

Options:

- Fully tooled in all Standard D38999 insert patterns
- Contact Amphenol for Firewall Capability
- Amphenol standard platings available for both aluminum and stainless steel shells
- Also available: thermocouple, filtering, custom, mixed keying arrangements, and high speed. Contact Amphenol for more information.

Features & Benefits:

- **Corrosion Resistance:**
Several Shell Finishes capable of withstanding 500 hours of salt spray.
- **Environmentally Sealed:**
Environmentally sealed when mated with Mil-Spec plug.
- **Gender Availability:**
Available in a variety of gender options tailored to your application needs.
- **Contact Protection:**
Recessed pins in this 100% scoop-proof connector minimize potential contact damage.
- **Versatile:**
Mates to standard D38999 plug connectors (D38999/26).
- **Temperature:**
Performs in ranges from -65°C through 200°C.



Bulkhead Feed-Through & Connector Savers

How to Order (Ex: BTV07RW-21-35SPB)



1. 2. 3. 4. 5. 6. 7.

Connector Type	Shell Style	Service Class	Shell Size - Insert Arrangement	Contact Type	Alternate Positions	Modifications
BTV	07	RW	21-35	SP	B	(Optional)

Note: Panel Accommodations .060 - .150"

1. Connector Type	
BTV	Bulkhead Feed-Through Connector
TVCS	Connector Saver





2. Shell Style	
00	Wall Mount Receptacle
01	Line Receptacle (Plug Adapter)
07	Jam Nut Receptacle
10	Wall Mount with Clinch Nuts
	Omit for Connector Saver

3. 175°C Service Class		
RW	Corrosion resistant olive drab cadmium plated aluminum, 500 hour extended salt spray	
DT	Durmalon plated, alternative to cadmium. Corrosion resistant, 500 hour extended salt spray	
DZ	Black Zinc-Nickel alternative to cadmium. 500 hour salt spray, conductive	
DW	Corrosion resistant olive drab cadmium plated aluminum, 1,000 hour extended salt spray	

4. Shell Size - Insert Arrangement	
9-	Fill in applicable 38999 Insert Pattern
11-	
13-	
15-	
17-	
19-	
21-	
25-	

5. Contact Type	
SP	Socket-Pin
PS	Pin-Socket
PP	Pin-Pin
SS	Socket-Socket

Note: For Jam Nut/Wall Mount versions the first letter designates the panel side of the connector (see drawing) while the second letter in the sequence designates the opposite side. The In-Line can be reversed. For connector savers, the first letter designates the contact gender on the plug side of the connector saver

3. 200°C Service Class		
RB	Marine Bronze - 500 hour salt spray	
RF	Electroless nickel plated aluminum, 48 hour salt spray	
RK	Corrosion resistant stainless steel, fire-wall capability, plus 500 hour salt spray resistance	
RL	Corrosion resistant steel, electro deposited nickel, 500 hour salt spray, non firewall	
DB	Black Electroless Nickel, 100 hour salt spray	

6. Alternate Position	
A, B, C, D, E omit for normal rotation parts. See page 84 for complete information	

7. Modifications	
(PWR)	Replace coax/twinax contacts with power contacts

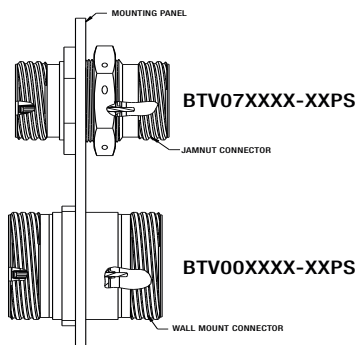

- PCB
- HD
- Power
- Bulk
- Integral
- Plug
- Hermetic
- Speed
- Filter
- Access
- Tech

Bulkhead Feed-Through Connectors

BTV00-Wall Mount, BTV10 Wall Mount with Clinch Nuts
BTV01-Line Mount

- PCB
- HD
- Power
- Bulk
- Integral
- Plug
- Hermetic
- Speed
- Filter
- Access
- Tech

BTV00 - Wall Mount

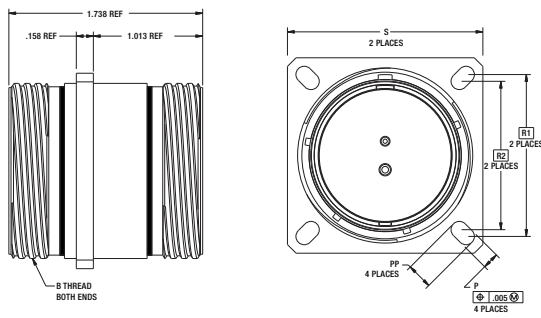

BTV10 - Wall Mount with Clinch Nuts

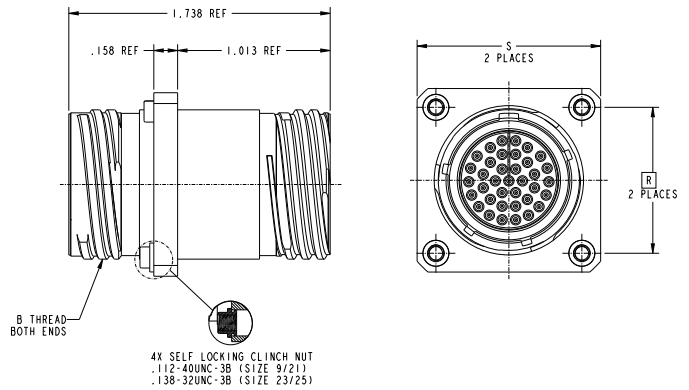

Connector Size	B Thread Class 2A, Blunt Start per 9-3200-2	P ±.007	PP ±.007	R1	R2	S ±.010
9	.6250-0.IP-0.3L-TS	.128	.216	.719	.594	.937
11	.7500-0.IP-0.3L-TS	.128	.194	.812	.719	1.031
13	.8750-0.IP-0.3L-TS	.128	.194	.906	.812	1.126
15	1.0000-0.IP-0.3L-TS	.128	.173	.969	.906	1.220
17	1.1875-0.IP-0.3L-TS	.128	.194	1.062	.969	1.311
19	1.2500-0.IP-0.3L-TS	.128	.194	1.156	1.062	1.437
21	1.3750-0.IP-0.3L-TS	.128	.194	1.250	1.156	1.563
23	1.5000-0.IP-0.3L-TS	.154	.242	1.375	1.250	1.689
25	1.6250-0.IP-0.3L-TS	.154	.242	1.500	1.375	1.811

BTV01- Line Mount

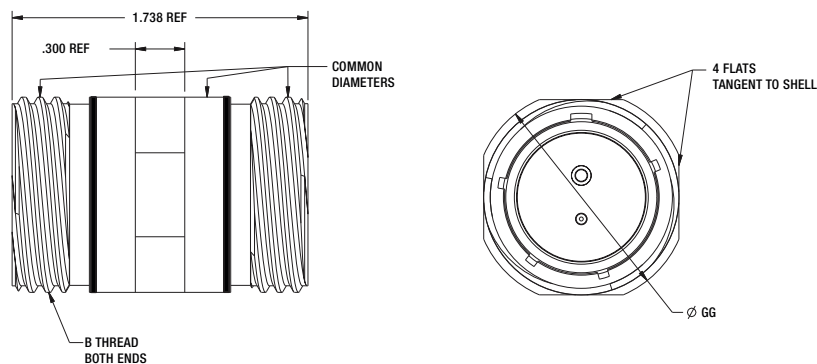

Connector Size	B Thread Class 2A, Blunt Start	Ø GG
9	.6250-0.IP0.3L-TS	.725
11	.7500-0.IP0.3L-TS	.850
13	.8750-0.IP0.3L-TS	.975
15	1.0000-0.IP0.3L-TS	1.100
17	1.1875-0.IP0.3L-TS	1.290
19	1.2500-0.IP0.3L-TS	1.350
21	1.3750-0.IP0.3L-TS	1.475
23	1.5000-0.IP0.3L-TS	1.600
25	1.6250-0.IP0.3L-TS	1.725

Bulkhead Feed-Through Connectors

BTV07 - Jam Nut

BTV07 - Jam Nut

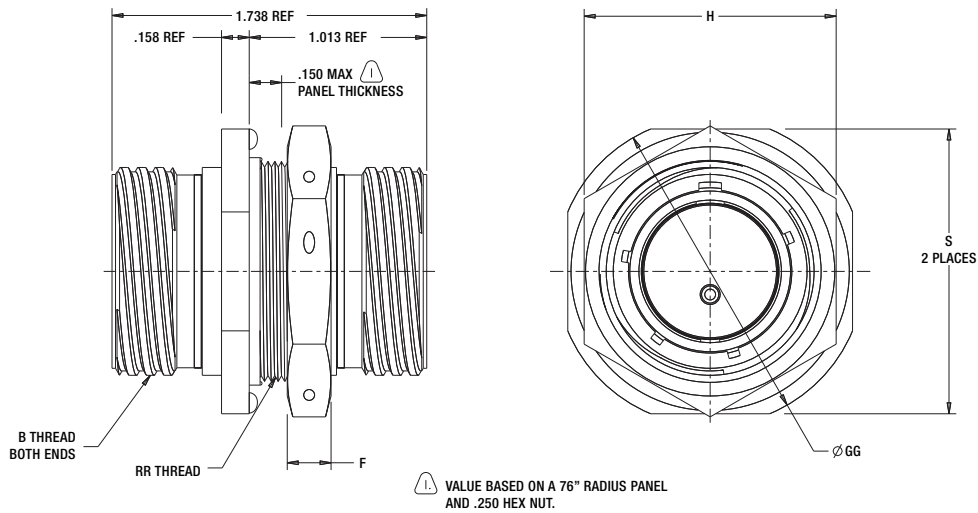

Connector Size	B Thread Class 2A	S	Ø GG	RR Thread		H Hex ±.016	F
9	.6250-0.IP-0.3L-TS	1.062	1.188	M17X1-6g	N/A	.875	.184 + .002 -.005
11	.7500-0.IP-0.3L-TS	1.250	1.375	M20X1-6g	N/A	1.000	
13	.8750-0.IP-0.3L-TS	1.375	1.500	M25X1-6g	N/A	1.188	.250 + .010 -.000
15	1.0000-0.IP-0.3L-TS	1.500	1.625	M28X1-6g	N/A	1.312	
17	1.1875-0.IP-0.3L-TS	1.625	1.750	M32X1-6g	31.92-31.80	1.438	
19	1.2500-0.IP-0.3L-TS	1.812	1.938	M35X1-6g	N/A	1.562	
21	1.3750-0.IP-0.3L-TS	1.938	2.062	M38X1-6g	N/A	1.688	
23	1.5000-0.IP-0.3L-TS	2.062	2.188	M41X1-6g	N/A	1.812	
25	1.6250-0.IP-0.3L-TS	2.188	2.312	M44X1-6g	N/A	2.000	

PCB
HD
Power
Bulk
Integral
Plug
Hermetic
Speed
Filter
Access
Tech

38999 Connectors with Integral Accessories



The 38999 Series III style connectors feature integral accessories that eliminate the need for an additional backshell

The backshell feature is incorporated into the rear of the connector shell, allowing the user to attach the shield of their cable directly to the connector, or provide strain relief for their wire bundle. This provides superior EMI shielding, enhanced sealing and ease for overmold applications. These are available in aluminum and stainless steel shells with most Amphenol platings.

Features & Benefits:

- Eliminates need for additional accessory
- Time savings during order and installation
- Cost effective
- Space and weight savings
- EMI protection
- Compatible with overmolding processes (Integral banding platform)
- Integral strain relief eliminates accessory backoff concern
- Eliminates industry problem of misaligned accessory teeth

Connectors with Integral Accessories

How to Order

1.	2.	3.	4.	5.	6.	7.
Connector Type	Shell Style	Service Class	Shell Size - Insert Arrangement	Contact Type	Alternate Position	Modifications (Optional)
TVS	76	DZ	15-35	P	A	

1. Connector Type	
TV	Tri-Start 175°C
TVS	Tri-Start 200°C
TVPS	Panel Mounted, 200°C

4. Shell Size - Insert Arrangement
See page 75-83 for Insert Arrangements chart and illustrations.



5. Contact Type	
P	Pin
S	Socket
H	1500 Cycle Pin Contacts
J	1500 Cycle Socket Contacts







7. Modifications (Optional)	
(PWR)	Replace coax/twinax contacts with power contacts

2. Shell Style	
96	Plug with Integral Banding Platform
87	Jam Nut with Integral Banding Platform
80	Wall Mount with Integral Banding Platform
81	Line Mount with Integral Banding Platform
76	Plug with Integral Strain Relief

6. Alternate Position Pg 84	
	Blank for normal rotation
A	A rotation
B	B rotation
C	C rotation
D	D rotation
E	E rotation

*See page 84 for more information.

3. 175°C Service Class		
RW	Corrosion resistant olive drab cadmium plated aluminum, 500 hour extended salt spray	
DT	Durmalon plated, alternative to cadmium. Corrosion resistant, 500 hour extended salt spray	
DZ	Black Zinc-Nickel alternative to cadmium. 500 hour salt spray, conductive	
DW	Corrosion resistant olive drab cadmium plated aluminum, 1,000 hour extended salt spray	

3. 200°C Service Class		
RB	Marine Bronze - 500 hour salt spray	
RF	Electroless nickel plated aluminum, 48 hour salt spray	
RK	Corrosion resistant stainless steel, fire-wall capability, plus 500 hour salt spray resistance	
RL	Corrosion resistant steel, electro deposited nickel, 500 hour salt spray, non firewall	
DB	Black Electroless Nickel, 100 hour salt spray	
DS	AP-93 Tri-Nickel Alloy, Aluminum, 1000 Hr., 200°C, -65dB@100Hz*	

PCB
HD
Power
Bulk
Integral
Plug
Hermetic
Speed
Filter
Access
Tech

Plug with Integral Banding Platform

TV96, TVS96

PART NUMBER BUILDER Page 29

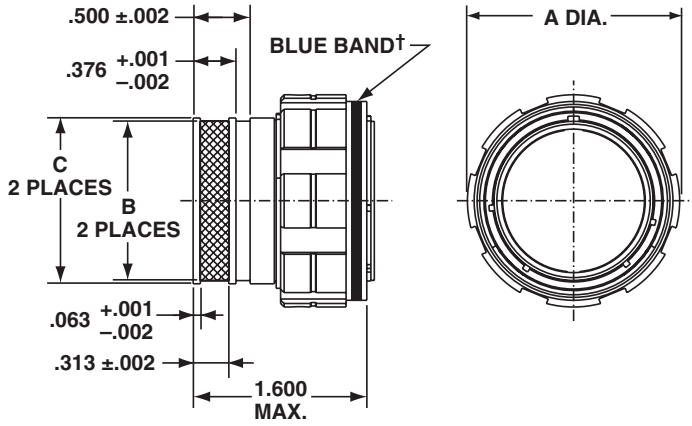

Shell Size	MS Shell Size Code	A Max.	B +.005 / -.000	C +.003 / -.002
9	A	.859	.416	.472
11	B	.969	.524	.580
13	C	1.141	.652	.708
15	D	1.266	.810	.866
17	E	1.391	.928	.984
19	F	1.500	1.046	1.102
21	G	1.625	1.164	1.220
23	H	1.750	1.282	1.338
25	J	1.875	1.400	1.456

Jam Nut with Integral Banding Platform

TV87, TVS87

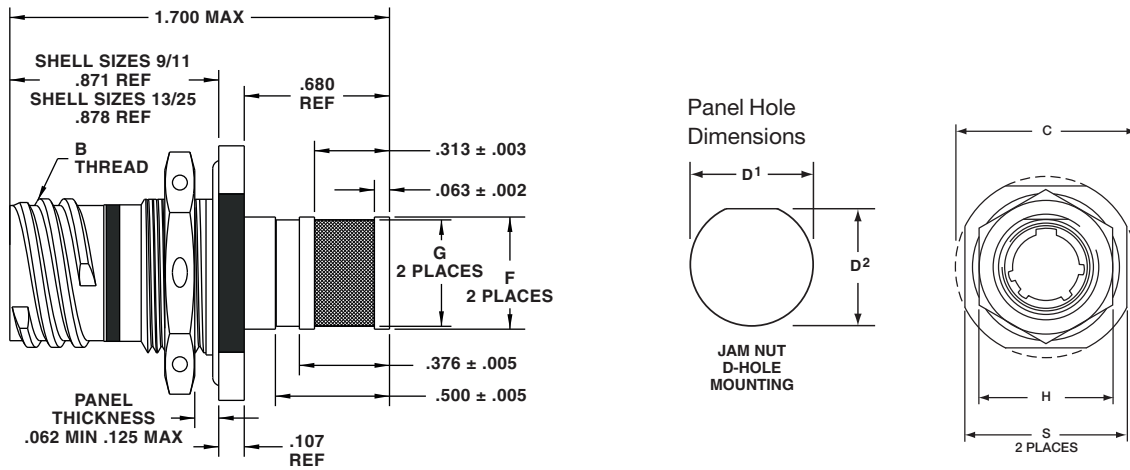

Shell Size	MS Shell Size Code	G +.005 / -.000	F +.003 / -.002	B Thread Class 2A 0.1P-0.3L-TS (Plated)	C Max.	D ¹ +.010 / -.000	D ² +.010 / -.000	H Hex +.017 / -.016	S ±.010
9	A	.416	.472	.6250	1.199	.693	.657	.875	1.062
11	B	.524	.580	.7500	1.386	.825	.770	1.000	1.250
13	C	.652	.708	.8750	1.511	1.010	.955	1.188	1.375
15	D	.810	.866	1.0000	1.636	1.135	1.085	1.312	1.500
17	E	.928	.984	1.1875	1.761	1.260	1.210	1.438	1.625
19	F	1.046	1.102	1.2500	1.949	1.385	1.335	1.562	1.812
21	G	1.164	1.220	1.3750	2.073	1.510	1.460	1.688	1.938
23	H	1.282	1.338	1.5000	2.199	1.635	1.585	1.812	2.062
25	J	1.400	1.456	1.6250	2.323	1.760	1.710	2.000	2.188

Wall Mount with Integral Banding Platform

TVP80, TVPS80

PART NUMBER BUILDER Page 29

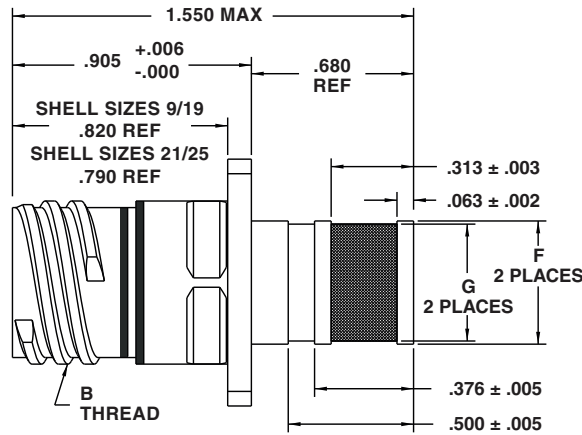
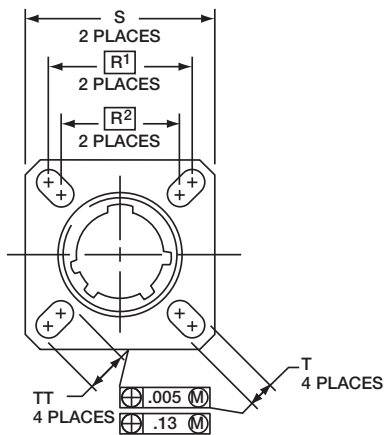

Panel Hole Dimensions

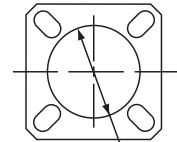

BACK PANEL MOUNTING

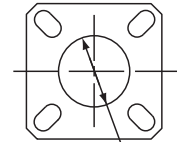

FRONT PANEL MOUNTING

Shell Size	MS Shell Size Code	G +.005 -.000	F +.003 -.002	B Thread Class 2A 0.1P-0.3L-TS (Plated)	R	R	S Max	T ±.008	A' Back Panel Mount	A'' Front Panel Mount	TT ±.008
9	A	.416	.472	.6250	.719	.594	.948	.128	.655	.516	.216
11	B	.524	.580	.7500	.812	.719	1.043	.128	.796	.625	.194
13	C	.652	.708	.8750	.906	.812	1.137	.128	.922	.750	.194
15	D	.810	.866	1.0000	.969	.906	1.232	.128	1.047	.906	.173
17	E	.928	.984	1.1875	1.062	.969	1.323	.128	1.219	1.016	.194
19	F	1.046	1.102	1.2500	1.156	1.062	1.449	.128	1.297	1.141	.194
21	G	1.164	1.220	1.3750	1.250	1.156	1.575	.128	1.442	1.266	.194
23	H	1.282	1.338	1.5000	1.375	1.250	1.701	.154	1.547	1.375	.242
25	J	1.400	1.456	1.6250	1.500	1.375	1.823	.154	1.672	1.484	.242

Plug with Integral Strain Relief

TV76, TVS76

Shell Size	MS Shell Size Code	A Max.	C	D DIA REF	L REF	T REF
9	A	0.859	0.688	0.950	1.890	0.815
11	B	0.969	0.812	1.110	1.985	0.910
13	C	1.141	0.945	1.270	2.080	1.005
15	D	1.266	1.062	1.430	2.175	1.100
17	E	1.391	1.250	1.590	2.270	1.195
19	F	1.500	1.344	1.750	2.365	1.290
21	G	1.625	1.500	1.880	2.490	1.415
23	H	1.750	1.656	2.010	2.615	1.540
25	J	1.875	1.781	2.150	2.740	1.665

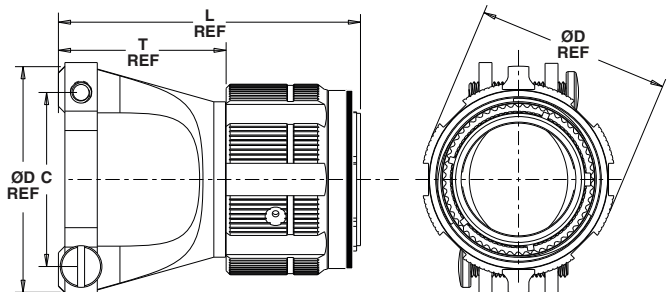

PCB
HD
Power
Bulk
Integral
Plug
Hermetic
Speed
Filter
Access
Tech

High Vibration Dualok

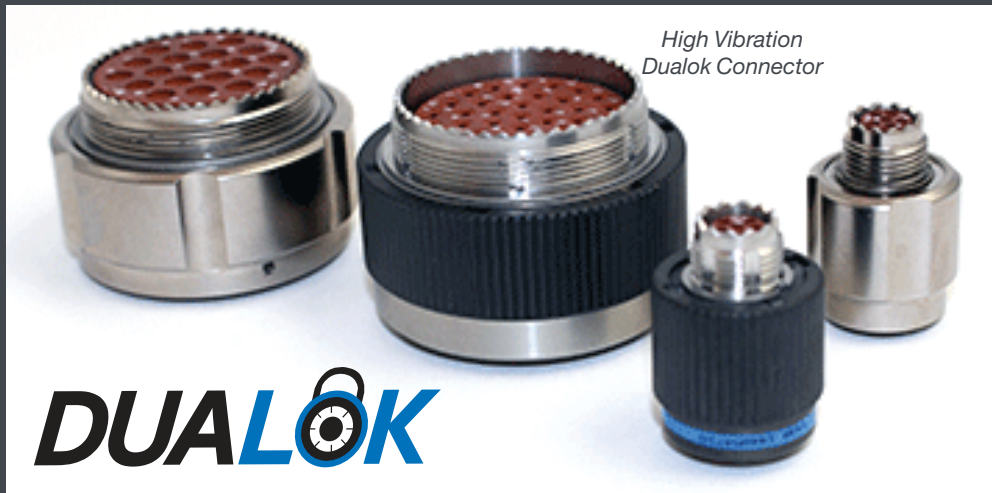

Testing on D38999 Series III aluminum plugs with Dualok showed 75% less millivolt drop than Mil-Spec requirements.

Dualok is an enhanced anti-decoupling mechanism designed to perform under severe vibration environments – far exceeding the performance of MIL-DTL-38999 Series III plugs.

The Dualok represents the latest in high performance connector designs from Amphenol. Featuring a newly developed locking mechanism, the Dualok plug ensures rock-solid coupling and metal-to-metal bottoming in the most severe vibration environments.

The Dualok system is proven to mitigate the negative effects of high vibration operation by eliminating connector back-off and reducing conditions that can cause fretting corrosion. Dualok is compatible with all D38999 Series III receptacle interfaces and has been qualified to Boeing Specification BACC63EK.



Features and Benefits:

- Mates with standard D38999 receptacles and utilizes standard D38999 inserts.
- Designed to withstand and stay mated under vibration levels that exceed MIL-DTL-38999 levels
- Dualok stainless steel provides a weight savings of up to 42% compared to standard D38999 stainless steel designs
- Stainless steel, aluminum, composite, or aluminum bronze materials of construction
- Dualok aluminum provides ~ 10% weight reduction over D38999 Aluminum
- Coupling mechanism that does not “settle” under vibration levels exceeding MIL-DTL-38999
- Metal-to-metal bottoming for maximum EMI shielding under extreme vibration
- Improved performance under lightning strikes



Minimized Contact Fretting:

The pin-socket interface remains tight under mated conditions. Dualok yields more consistent integrity across the contacts and reduces friction-induced oxides formation.



High Vibration Dualok, 38999 Series III Type

How to Order (TV56, TVS56)

1.	2.	3.	4.	5.	6.
Connector Type	Shell Style	Service Class	Shell Size - Insert Arrangement	Contact Type	Alternate Position
TVS	56	RF	15-35	P	A

1. Connector Type	
TV	Tri-Start 175°C
TVS	Tri-Start 200°C







2. Shell Style	
56	Dualok Plug

3. 175°C Service Class		
RW	Corrosion resistant olive drab cadmium plated aluminum, 500 hour extended salt spray	
DT	Durmalon plated, alternative to cadmium. Corrosion resistant, 500 hour extended salt spray	
DZ	Black Zinc-Nickel alternative to cadmium. 500 hour salt spray, conductive	

4. Shell Size - Insert Arrangement	
Shell Size & Insert Arrangements are on pages 75-83. First number represents Shell Size, second number is the Insert Arrangement. * Size 7 and 7H are Double Start Threads only	

5. Contact Type	
P	500 Cycle Pin Contacts
S	500 Cycle Socket Contacts
H	1500 Cycle Pin Contacts
J	1500 Cycle Socket Contacts

6. Alternate Position	
See page 84 for complete information	

3. 200°C Service Class		
RF	Electroless nickel plated aluminum, 48 hour salt spray	
RK	Corrosion resistant stainless steel, firewall capability, plus 500 hour salt spray resistance	
RKN	Corrosion resistant stainless steel, Nonfirewall capability, plus 500 hour salt spray resistance	
RL	Corrosion resistant steel, electro deposited nickel, 500 hour salt spray, non firewall	
RS	(Non-hermetic connectors), Nickel plated, corrosion resistant steel, firewall capability, 500 hour salt spray	
DS	AP-93 Tri-Nickel Alloy, Aluminum, 1000 Hr., 200°C, -65dB@100Hz*	

*Firewall connectors have stainless steel shell and coupling nut.

*Non-Firewall connectors have stainless steel shell and composite coupling nut.

- PCB
- HD
- Power
- Bulk
- Integral
- Plug
- Hermetic
- Speed
- Filter
- Access
- Tech

High Vibration Dualok 38999 Series III Type

Plug (TV56, TVS56, CTV56, CTVS56)

PART NUMBER BUILDER Page 33

- PCB
- HD
- Power
- Bulk
- Integral
- Plug
- Hermetic
- Speed
- Filter
- Access
- Tech

ALUMINUM	COMPOSITE	STAINLESS STEEL
TVS56RF	CTVS56RF	TVS56RK
TV56RW	CTV56RW	TVS56RKN
TV56DT	CTV56RGF	TVS56RS
TV56DZ	CTV56RGW	TVS56RL
TV56RGF		
TV56RGW		
TVS56RB		

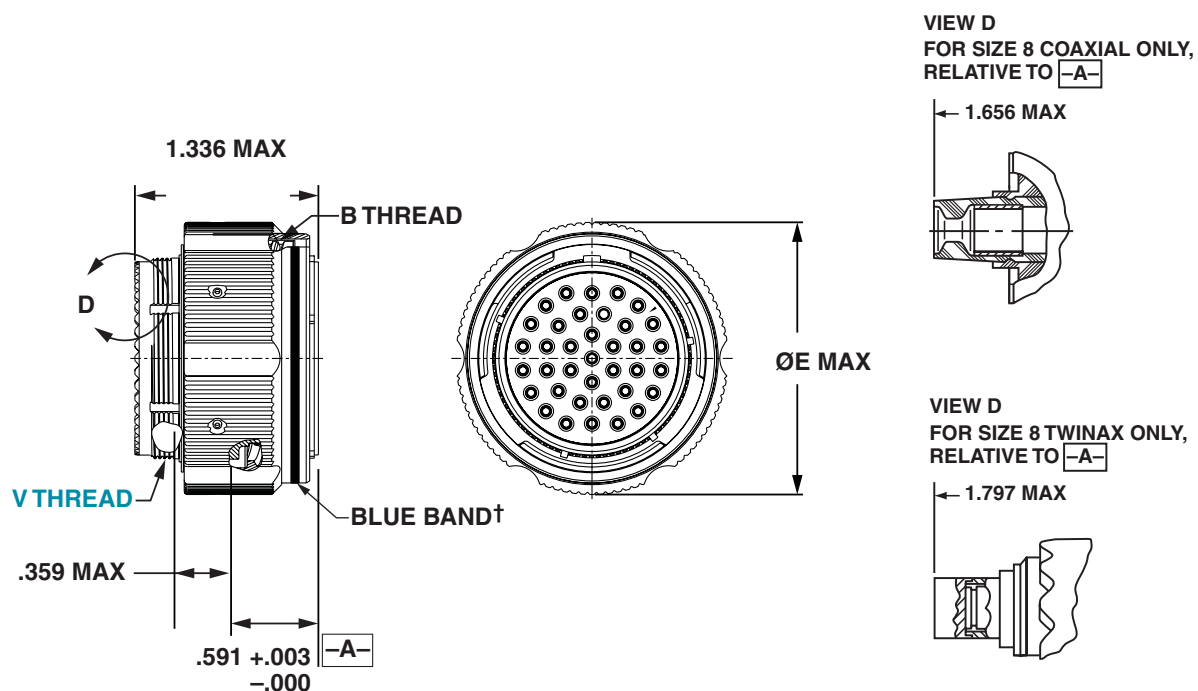

Shell Size	B Thread 0.1-0.3L-TS-2B (Plated)	E Dia. Max.	V Thread Metric.
9	.6250	.953	M12X1-6g
11	.7500	1.053	M15X1-6g
13	.8750	1.252	M18X1-6g
15	1.0000	1.365	M22X1-6g
19	1.2500	1.605	M28X1-6g
21	1.3750	1.735	M31X1-6g
25	1.6250	1.975	M37X1-6g



38999 Series III, TV, Plugs

How to Order (Commercial)

1.	2.	3.	4.	5.	6.	7.
Connector Type	Shell Style	Service Class	Shell Size - Insert Arrangement	Contact Type	Alternate Position	Modifications
TV or TVS	06	RF	15-35	P	A	(474)

1. Connector Type	
TV	Plug, 175°C
TVS	Plug, 200°C

2. Shell Style	
06	Straight Plug
09	Flange Mounted Plug









3. 175°C Service Class		
RW	Corrosion resistant olive drab cadmium plated aluminum, 500 hour extended salt spray	
DT	Durmalon plated, alternative to cadmium. Corrosion resistant, 500 hour extended salt spray	
DZ	Black Zinc-Nickel alternative to cadmium. 500 hour salt spray, conductive	
DW	Corrosion resistant olive drab cadmium plated aluminum, 1,000 hour extended salt spray	

4. Shell Size - Insert Arrangement
Shell Size & Insert Arrangements are on pages 75-83. First number represents Shell Size, second number is the Insert Arrangement.

5. Contact Type	
P	Pin Contacts
S	Socket Contacts
H	1500 Cycle Pin Contacts
J	1500 Cycle Socket Contacts

6. Alternate Position
A, B, C, D, E omit for normal rotation parts. See page 84 for complete information

7. Modifications	
(474)	RotoLok Plug see page 36
(734)	Wing Nut Plug (Glove applications) see page 36
Contact Amphenol for other modification codes.	

3. 200°C Service Class		
RB	Marine Bronze - 500 hour salt spray	
RF	Electroless nickel plated aluminum, 48 hour salt spray	
RK	Corrosion resistant stainless steel, firewall capability, plus 500 hour salt spray resistance	
RKN	Corrosion resistant stainless steel, Nonfirewall capability, plus 500 hour salt spray resistance	
RL	Corrosion resistant steel, electro deposited nickel, 500 hour salt spray, non firewall	
RS	Nickel plated, corrosion resistant steel, firewall capability, 500 hour salt spray	
DB	Black Electroless Nickel, 100 hour salt spray	
DS	AP-93 Tri-Nickel Alloy, Aluminum, 1000 Hr., 200°C, -65dB@100Hz*	

- PCB
- HD
- Power
- Bulk
- Integral
- Plug
- Hermetic
- Speed
- Filter
- Access
- Tech

RotoLok High Vibration Plug Solutions

Add the (474) suffix to the end of TV06 or TVS06 Part Number

PART NUMBER BUILDER Page 33

Amphenol extends its high vibration family of products with the RotoLok plugs. These plugs have been tried and tested for years in the field and remain a trusted product for high vibration requirements in the most demanding of environments.

Please refer to page 33 How-to-order. Add suffix (474) to modification code to order RotoLok high vibration plug

TV06 - add suffix (474)
TVS06 - add suffix (474)



- All Aluminum shell sizes available in most finishes
- Intermateable with any MIL-DTL-38999 Series III receptacle and accessory
- Improves electrical performance by minimizing contact fretting
- EMI/RFI shielding advantages of D38999 Series III plugs

Wing Nut Plug

Add the (734) suffix to the end of TV06 or TVS06 Part Number

TV06 - add suffix (734)
TVS06 - add suffix (734)

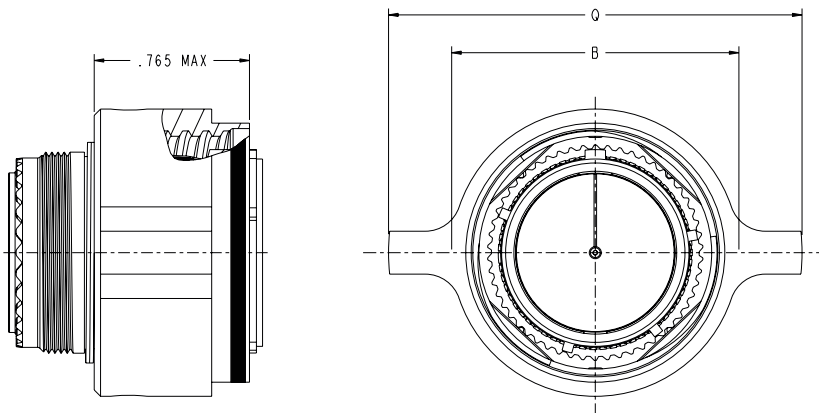

Shell Size	B Thread 0.1P-0.3L-YS (Plated)	B Dia. Max.	B Dia. Max.	Q Dia. Max.
9	.6250	.830	.830	1.485
11	.7500	.935	.935	1.598
13	.8750	1.106	1.106	1.772
15	1.0000	1.234	1.234	1.898
17	1.1875	1.371	1.371	2.024
19	1.2500	1.478	1.478	2.134
21	1.3750	1.605	1.605	2.256
23	1.5000	1.722	1.722	2.382
25	1.6250	1.849	1.849	2.677

TV Breakaway Fail-Safe Lanyard Release

Commercial version of D38999/31, Type 6 & others



**Quick-disconnect
with an axial pull
of lanyard**

Features and Benefits:

- 25 lanyard lengths
- Available in all size 25 arrangements
- Low force separation capabilities
- Compatible with all mil-spec backshells and accessories
- Mates to existing D38999 receptacles

Amphenol offers a commercial version of D38999/31 Series III, Type 6 connectors. Built from the same time-tested and quality components used in its Mil-Spec counterpart, Amphenol's commercial variant is designed to accept a wider variety of insert arrangements the Mil-Spec does not include. Available in shell size 25, these fail-safe connectors adopt an incredible amount of versatility without sacrificing performance or durability. Consult Amphenol Aerospace for more information.



Backshells are offered for use with Breakaway Fail Safe Connectors in three heights

Low Profile Backshells in shell size 25 with the following features:

- 90 degree termination
- Low profile design with three heights ranging from 1.010 to 1.660
- Rear access covers to help ease harness assembly and repairability
- Amphenol part numbers: 10-640000-XXX

Other Advantages Include:

- Lower profile compared to full metal breakaway Fail-Safe connectors
- Less weight
- Meets MIL-DTL-38999/31
- Random & sine vibration
- Ice resistance
- Fluid immersion and hydrolytic stability test.
- Available in shell sizes 25 and 17

Metal shells with Composite Operating Sleeve

New Hybrid Lanyard Breakaway Fail-Safe connector with a composite thermoplastic outer operating sleeve for greater durability.

Amphenol's hybrid lanyard design offers greater durability over D38999 aluminum and composite designs because of its ability to handle abuse taken after weapons release.

TV Breakaway Fail-Safe Lanyard Release

Commercial (725010, 725014, 725041) Version of D38999/31 Type 6

HOW TO ORDER

1.	2.	3.	4.	5.
Service Class	Shell Style	Insert Arrg.	Alternate Keying Position (End A)	Lanyard Length Code
88-	725010-	04	P	K

1. Service Class*	
88-	Olive Drab Cadmium
91-	Electroless Nickel
F2-	Black Zinc-Nickel alternative to cadmium. Corrosion resistant, 500 hour salt spray, 175°C
F7-	Durmalon plated, alternative to cadmium. Corrosion resistant, 500 hour extended salt spray, 175°C

2. Shell Style	
725010-	D38999/31 Type 6
725014-	Extended Backskirt
725041-	Integrated Banding Platform

3. Insert Arrangement	
04	25-4
07	25-7
11	25-11
17	25-17
20	25-20
24	25-24
26	25-26
29	25-29
35	25-35
37	25-37
41	25-41
43	25-43
46	25-46
61	25-61
62	25-62
90	25-90
F4	25-F4
187	25-187

4. Keying		
Key Position	Pin	Socket
N	P	S
A	G	H
B	I	J
C	K	L
D	M	N
E	R	T

5. Lanyard Length Code		
Lanyard Length (in.) ± .236	Lanyard Length (mm) ± 6.0	Lanyard Length Code For Part Number
4.016	102	A
4.528	115	B
5.000	127	C
5.512	140	D
6.024	153	E
6.535	166	F
7.008	178	G
7.520	191	H
7.992	203	I
8.503	216	J
9.016	229	K
9.528	242	L
10.000	254	M
10.512	267	N
11.024	280	P
11.535	293	R
12.008	305	S
12.520	318	T
13.031	331	U
14.016	356	V
15.000	381	W
16.024	407	X
17.008	432	Y
18.031	458	Z

* Contact Amphenol for availability of other finishes.

- PCB
- HD
- Power
- Bulk
- Integral
- Plug
- Hermetic
- Speed
- Filter
- Access
- Tech

TV Breakaway Fail-Safe Lanyard Release

Commercial (725010) Version of D38999/31 Type 6

PART NUMBER BUILDER Page 38

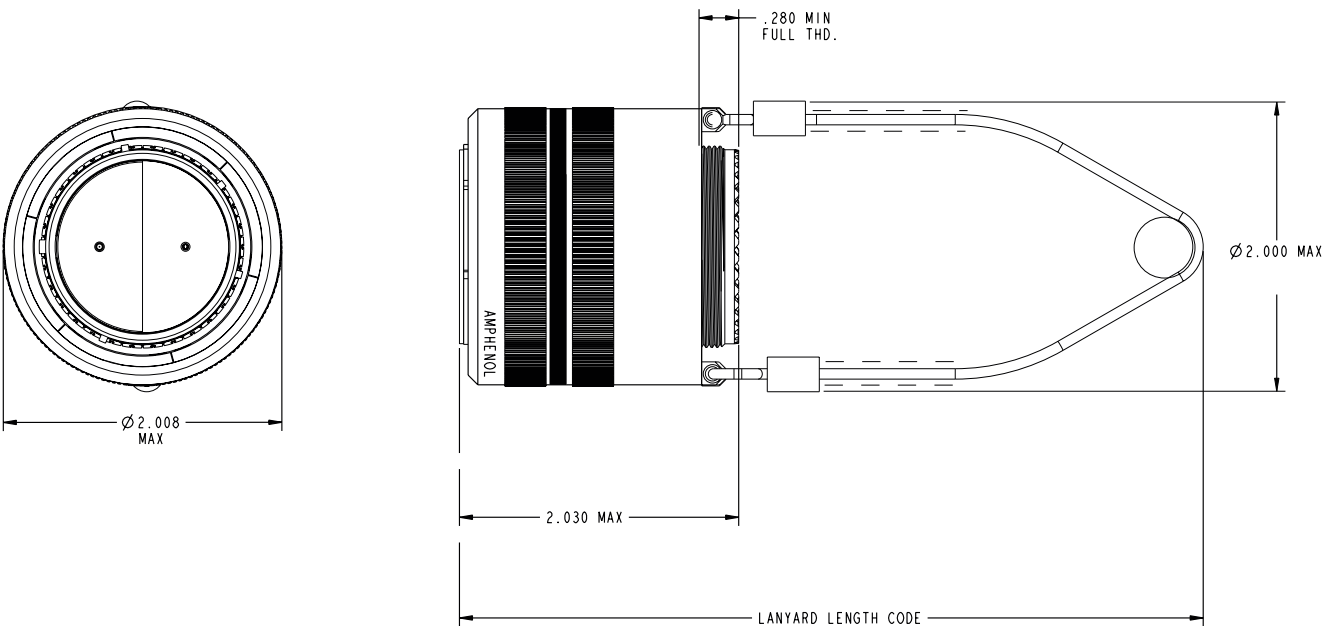

- PCB
- HD
- Power
- Bulk
- Integral
- Plug
- Hermetic
- Speed
- Filter
- Access
- Tech

TV Breakaway Fail-Safe Lanyard Release

Commercial (725014 & 725041) Version of D38999/31 Type 6

PART NUMBER BUILDER Page 38

PCB

HD

Power

Bulk

Integral

Plug

Hermetic

Speed

Filter

Access

Tech

725041 Integrated Banding Platform

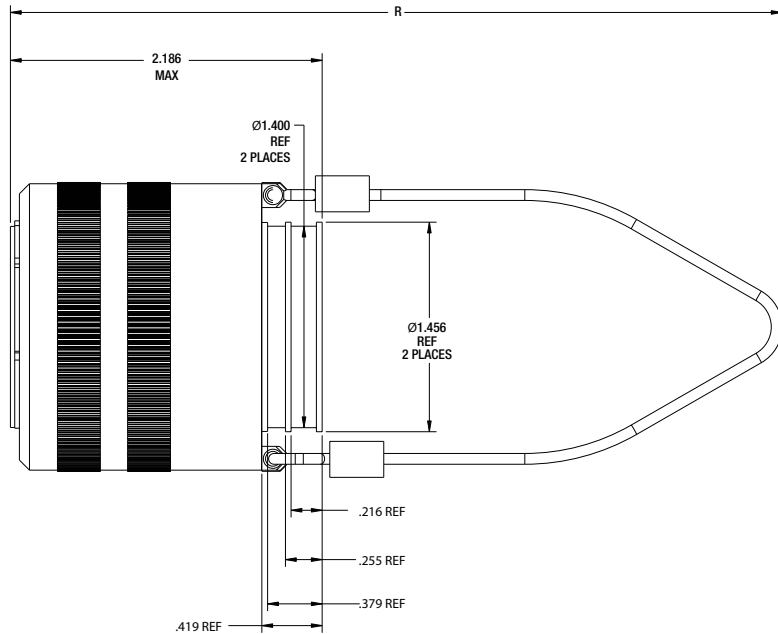
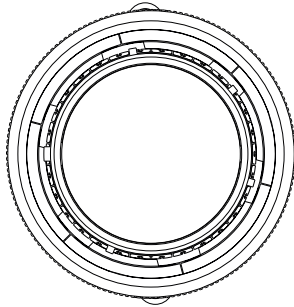

88-725014 Extended Backskirt

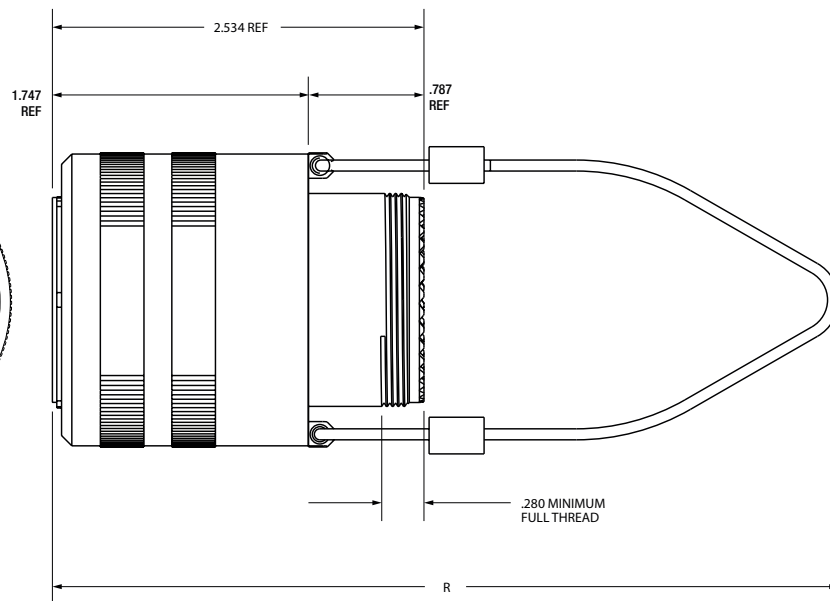
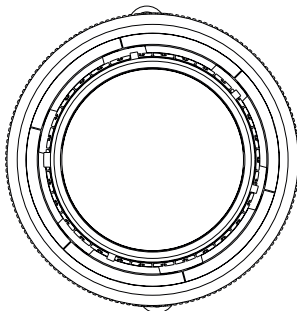

TV Breakaway Fail-Safe Lanyard Release Plug **Amphenol**

Aerospace

(88-5565 & 91-5565) Commercial Version of D38999/29 and /30

HOW TO ORDER

1.	2.	3.	4.	5.	6.
Service Class	Shell Style	Insert Arrg.	Required Field	Lanyard Length Code	Contact Type/Alternate Keying Position
88-	5565-	04	0	P	K

1. Service Class*	
88-	Olive Drab Cadmium
91-	Electroless Nickel
F2-	Black Zinc-Nickel alternative to cadmium. Corrosion resistant, 500 hour salt spray, conductive, -65°C to +175°C
F7-	Durmalon plated, alternative to cadmium. Corrosion resistant, 500 hour extended salt spray, 175°C

* Contact Amphenol for availability of other finishes.

2. Shell Style	
5565-	Designates MIL-DTL-38999, Series III Tri-Start Lanyard Release Plug

3. Insert Arrangement		3. Insert Arrangement	
08	11-2	40	19-35
06	11-35	47	21-11
07	11-98	48	21-16
10	13-4	49	21-35
11	13-8	51	21-39
14	13-35	50	21-41
13	13-98	57	23-21
18	15-5	58	23-35
23	15-15	59	23-53
22	15-18	61	23-54
19	15-19	60	23-55
20	15-35	71	25-4
21	15-97	66	25-19
27	17-6	74	25-20
28	17-8	72	25-24
29	17-26	67	25-29
30	17-35	68	25-35
31	17-99	69	25-43
37	19-11	73	25-46
39	19-32	70	25-61

* Contact Amphenol for other availability arrangement.

4. Required Field	
0	The required field is always 0

5. Lanyard Length Code		
Lanyard Length (in.) ± .236	Lanyard Length (mm) ± 6.0	Lanyard Length Code For Part Number
4.016	102	A
4.528	115	B
5.000	127	C
5.512	140	D
6.024	153	E
6.535	166	F
7.008	178	G
7.520	191	H
7.992	203	I
8.503	216	J
9.016	229	K
9.528	242	L
10.000	254	M
10.512	267	N
11.024	280	P
11.535	293	R
12.008	305	S
12.520	318	T
13.031	331	U
14.016	356	V
15.000	381	W
16.024	407	X
17.008	432	Y
18.031	458	Z

METAL

.374 MAX OUTER SLEEVE MOVEMENT DURING UNMATING THREAD RELEASE

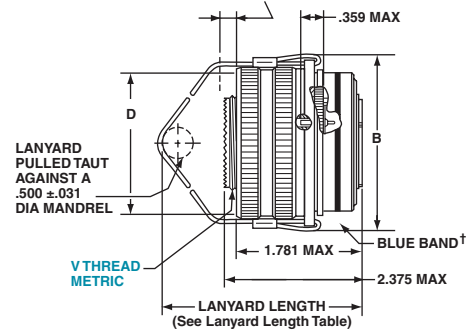

† Blue band indicates rear release contact retention system

Shell Size	MS Shell Size Code	B Max	D Max Accessory Dia.
11	B	1.846	1.109
13	C	1.972	1.250
15	D	2.079	1.375
17	E	2.205	1.500
19	F	2.301	1.625
21	G	2.472	1.750
23	H	2.594	1.875
25	J	2.705	2.000

6. Contact Type/Alternate Keying Position			
Pin Contacts		Socket Contacts	
MS Letter	Amphenol letter	MS Letter	Amphenol Letter
PN	P (normal)	SN	S (normal)
PA	G	SA	H
PB	I	SB	J
PC	K	SC	L
PD	M	SD	N
PE	R	SE	T

PCB Hermetic Series III

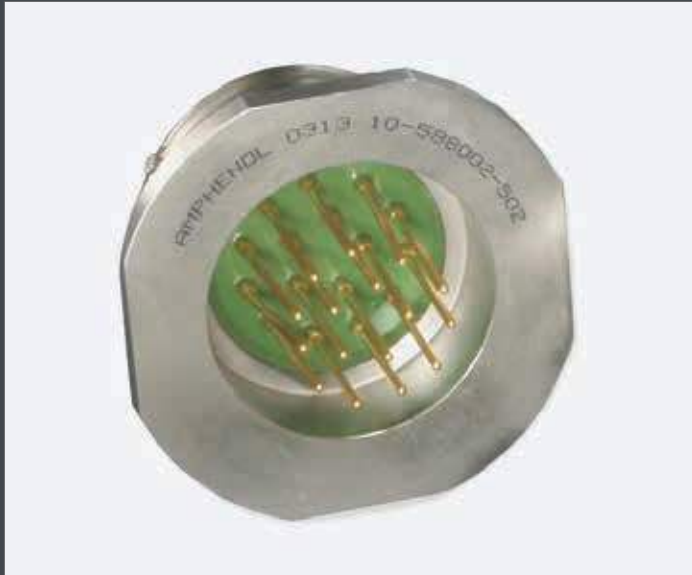

Tri-Start, MIL-DTL-38999, Series III with Stainless Steel shells

Amphenol Tri-Start 38999 Series III hermetic connectors offer the highest performance capabilities for severe environment applications; meeting or exceeding MIL-DTL-38999 Series III requirements.



Features:

- **Hermetic**
Air leakage limited to 1×10^{-7} cm³ per second
- **Fused Glass**
Fused glass in stainless or carbon steel shell
- **Tail Lengths**
Three standard stickout lengths available



Stainless Steel with Nickel Plating



Passivated Stainless Steel and Carbon Stainless Steel

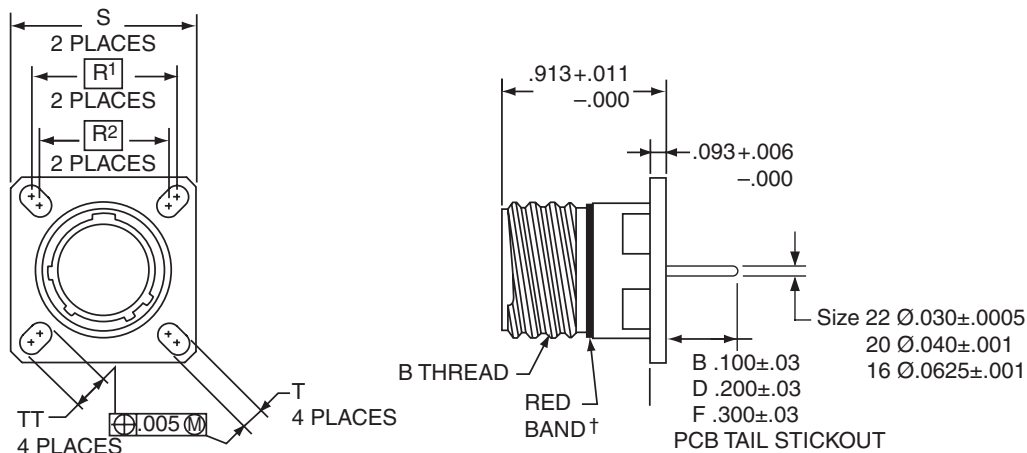

	1.	2.	3.	4.	5.	6.
PART # See chart below	Base Number 10-626	Coded Shell Size 501	Insert Arrg. -35	Contact Type/ Alt. Keying P	Shell Finish 1	Tail Length B

HOW TO ORDER

1. Base Number	
10-626	Base Number for MIL-DTL-38999 Series III Hermetic with PCB Tail

2. Coded Shell Size	
See chart below 501-509 , designates size 9-25 shell size.	

3. Insert Arrangements	
-35	Designates Insert Arrangement Number. Refer to chart on pages 75-83.

4. Contact Type/Alternate Keying	
P	Designates Pin Contacts in Normal Position.

Refer to page 84 for alternate rotation letters to use.

5. Shell Finish	
1	Hermetic seal, passivated Stainless Steel, 200°C
2	Hermetic seal, Stainless Steel w/Nickel Plate
3	Carbon Steel w/reflowed tin plate

6. Tail Length	
B	.100±.03
D	.200±.03
F	.300±.03

Shell Size	Part Number	B Thread 0.1P-0.3L-TS (Plated)	R1	R2	S ±.010	T ±.008	TT ±.008
9	10-626 501 -XXX	.6250	.719	.594	.938	.128	.216
11	502 -XXX	.7500	.812	.719	1.031	.128	.194
13	503 -XXX	.8750	.906	.812	1.125	.128	.194
15	504 -XXX	1.0000	.969	.906	1.219	.128	.173
17	505 -XXX	1.1875	1.062	.969	1.312	.128	.194
19	506 -XXX	1.2500	1.156	1.062	1.438	.128	.194
21	507 -XXX	1.3750	1.250	1.156	1.562	.128	.194
23	508 -XXX	1.5000	1.375	1.250	1.688	.154	.242
25	509 -XXX	1.6250	1.500	1.375	1.812	.154	.242

† Red band indicates fully mated

NOTE: Consult Amphenol Aerospace for availability of non-glass-sealed versions with printed circuit tail contacts.

All dimensions for reference.

□ Designates true position dimensioning



PCB Hermetic Jam Nut Receptacle

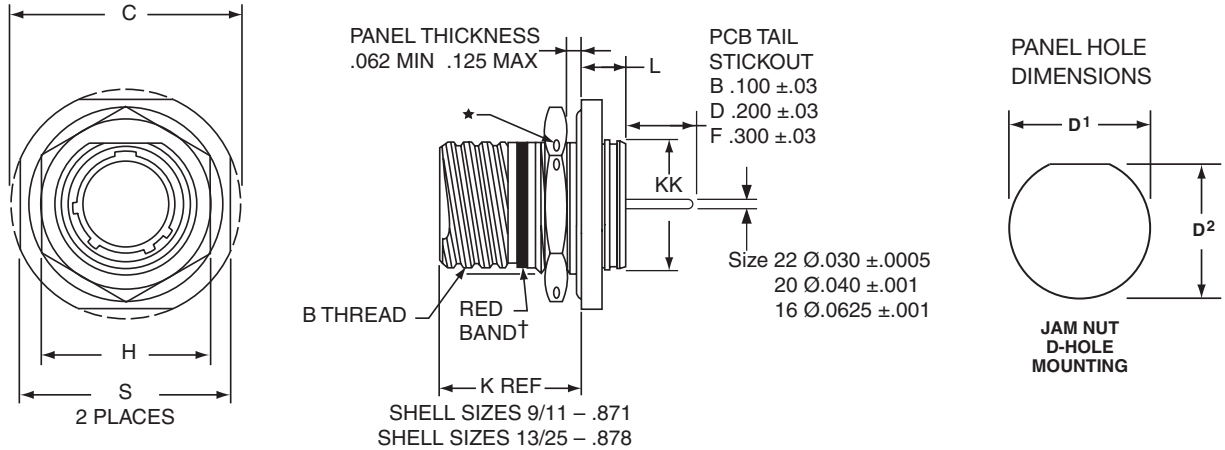

	1.	2.	3.	4.	5.	6.
PART #	Base Number	Coded Shell Size	Insert Arrg.	Contact Type/Alt. Keying	Shell Finish	Tail Length
See chart below	10-626	471	-35	P	1	B

HOW TO ORDER

1. Base Number

10-626	Base Number for MIL-DTL-38999 Series III Hermetic with PCB Tail
---------------	---

2. Coded Shell Size

See chart below **471-479**, designates size **9-25** shell size.

3. Insert Arrangements

-35	Designates Insert Arrangement Number. Refer to chart on pages 75-83.
------------	--

† Red band indicates fully mated

* .059 dia. min. (1.5 dia. min.) 3 lockwire holes. Formed lockwire hole design (6 holes) is optional.

4. Contact Type/Alternate Keying

P	Designates Pin Contacts in Normal Position.
----------	---

Refer to page 84 for alternate rotation letters to use.

5. Shell Finish

1	Hermetic seal, passivated Stainless Steel, 200°C
2	Hermetic seal, Stainless Steel w/Nickel Plate
3	Carbon Steel w/reflowed tin plate

6. Tail Length

B	.100±.03
D	.200±.03
F	.300±.03

Shell Size	Part Number	A+ +.000 -.010	B Thread Class 2A 0.1P-0.3L- TS (Plated)	C Max	D1 +.010 -.000	D1 +.000 -.010	H Hex +.017 -.016	L Max	S ±.010	T+ +.010 -.000	KK ±.011 -.000
9	10-626471-XXX	.669	.6250	1.199	.700	.670	.875	.357	1.062	.697	.642
11	472-XXX	.769	.7500	1.386	.825	.770	1.000	.357	1.250	.822	.766
13	473-XXX	.955	.8750	1.511	1.010	.955	1.188	.357	1.375	1.007	.892
15	474-XXX	1.084	1.0000	1.636	1.135	1.085	1.312	.357	1.500	1.134	1.018
17	475-XXX	1.208	1.1875	1.761	1.260	1.210	1.438	.357	1.625	1.259	1.142
19	476-XXX	1.333	1.2500	1.949	1.385	1.335	1.562	.381	1.182	1.384	1.268
21	477-XXX	1.459	1.3750	2.073	1.510	1.460	1.688	.381	1.938	1.507	1.392
23	478-XXX	1.575	1.5000	2.199	1.635	1.585	1.812	.381	2.062	1.634	1.518
25	479-XXX	1.709	1.6250	2.323	1.760	1.710	2.000	.381	2.188	1.759	1.642

All dimensions for reference only.

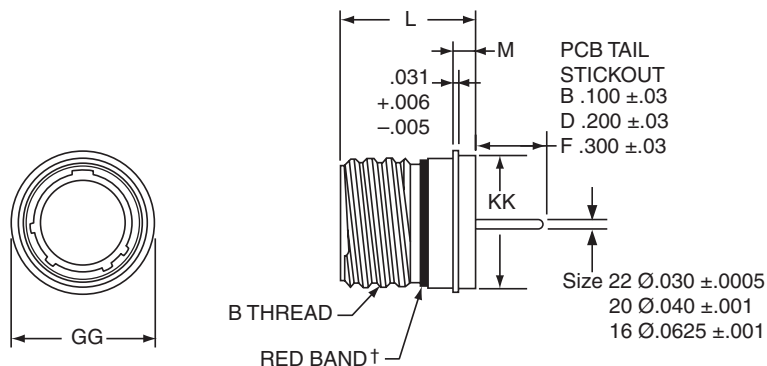

	1.	2.	3.	4.	5.	6.
PART #	Base Number	Coded Shell Size	Insert Arrg.	Contact Type/ Alt. Keying	Shell Finish	Tail Length
See chart below	10-626	481	-35	P	1	B

HOW TO ORDER

1. Base Number

10-626	Base Number for MIL-DTL-38999 Series III Hermetic with PCB Tail
---------------	---

4. Contact Type/Alternate Keying

P	Designates Pin Contacts in Normal Position.
----------	---

Refer to page 84 for alternate rotation letters to use.

2. Coded Shell Size

See chart below **481-489**, designates size **9-25** shell size.

5. Shell Finish

1	Hermetic seal, passivated Stainless Steel, 200°C
2	Hermetic seal, Stainless Steel w/Nickel Plate
3	Carbon Steel w/reflowed tin plate

3. Insert Arrangements

-35	Designates Insert Arrangement Number. Refer to chart on pages 75-83.
------------	--

6. Tail Length

B	.100±.03
D	.200±.03
F	.300±.03

† Red band indicates fully mated

Shell Size	Part Number	B Thread Class 2A 0.1P-0.3L- TS (Plated)	L +.011 -.005	M +.006 -.005	GG Dia. +.011 -.010	KK Dia +.011 -.005
9	10-626481-XXX	.6250	.806	.125	.750	.672
11	482-XXX	.7500	.806	.125	.844	.781
13	483-XXX	.8750	.806	.125	.969	.906
15	484-XXX	1.0000	.806	.125	1.094	1.031
17	485-XXX	1.1875	.806	.125	1.218	1.156
19	486-XXX	1.2500	.806	.125	1.312	1.250
21	487-XXX	1.3750	.806	.125	1.438	1.375
23	488-XXX	1.5000	.838	.156	1.563	1.500
25	489-XXX	1.6250	.838	.156	1.688	1.625



PCB Hermetic Weld Mounting Receptacle

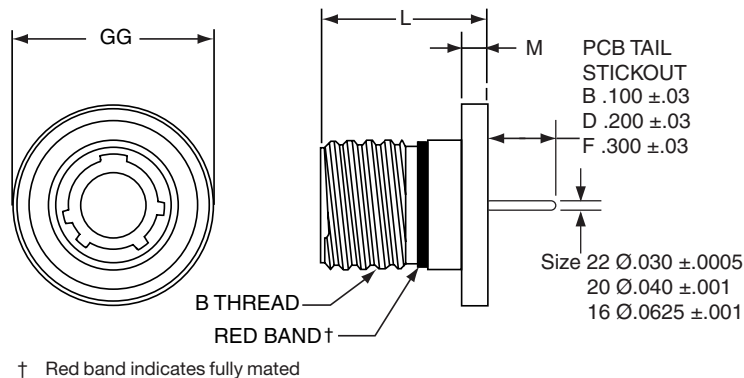

	1.	2.	3.	4.	5.	6.
PART #	Base Number	Coded Shell Size	Insert Arrg.	Contact Type/ Alt. Keying	Shell Finish	Tail Length
See chart below	10-626	491	-35	P	1	B

HOW TO ORDER

1. Base Number

10-626

Base Number for MIL-DTL-38999 Series III Hermetic with PCB Tail

4. Contact Type/Alternate Keying

P

Designates Pin Contacts in Normal Position.

Refer to page 84 for alternate rotation letters to use.

2. Coded Shell Size

See chart below **491-499**, designates size **9-25** shell size.

5. Shell Finish

- 1** Hermetic seal, passivated Stainless Steel, 200°C
- 2** Hermetic seal, Stainless Steel w/Nickel Plate
- 3** Carbon Steel w/reflowed tin plate

3. Insert Arrangements

-35

Designates Insert Arrangement Number. Refer to chart on pages 75-83.

6. Tail Length

- B** .100±.03
- D** .200±.03
- F** .300±.03

Shell Size	Part Number	B Thread Class 2A 0.1P-0.3L-TS (Plated)	L +.011 -.000	M +.006 -.005	GG Dia. +.011 -.010
9	10-626491-XXX	.6250	.806	.125	.973
11	492-XXX	.7500	.806	.125	1.095
13	493-XXX	.8750	.806	.125	1.221
15	494-XXX	1.0000	.806	.125	1.347
17	495-XXX	1.1875	.806	.125	1.434
19	496-XXX	1.2500	.806	.125	1.579
21	497-XXX	1.3750	.806	.125	1.721
23	498-XXX	1.5000	.838	.156	1.886
25	499-XXX	1.6250	.838	.156	1.973

* Not available for weld mount. All dimensions for reference only.

AmpheSEAL

38999 High Pressure Solution



The AmpheSEAL connectors provide sealing between the plug and receptacle interfaces and have been tested to withstand pressure to at least 300 PSI. Not intermateable with standard products. Must use AmpheSEAL on both sides of mated pair.

Features:

- Internal O-ring seals to at least 300 PSI
- Rear connector sealing method customized to meet the specific application
- Any D38999 size and insert arrangement is available
- All Aluminum shell sizes available in most finishes
- EMI/RFI shielding advantages of D38999 Series III plugs
- Contact Amphenol for how to order information

Ground Plane Connectors

Coax/Triax/Twinax



For High Speed Data Bus, LAN and Coax, Triax and Twinax Data Transmission:

MIL-DTL-38999 type connectors are available with metal inserts to maintain a common ground plane with the connector shell for all the shielded contacts contained in the connector.

These electrical connectors are available for all MIL-DTL-38999 insert patterns using size 16, 10, 12 or 8 contacts. This data sheet contains some of the popular insert patterns that are commonly used for ground plane connector applications. Options include crimp termination and printed circuit tail contacts in either solder or compliant pin configurations. Composite shells are also available. To order contact Amphenol Aerospace.

Applications:

Applications for ground plane connectors include MIL-STD 1553B data bus as well as video, signal and multiplex transmission.

Insert Arrangement Available

9-5
11-2
13-4
15-5
15-15
15-97
17-2
17-6
17-8
17-22
17-99
19-11
19-31
21-11
21-16
21-39
21-75
23-21
23-54
25-4
25-11
25-19
25-20
25-24
25-29
25-37
25-43
25-46

OCS (Oval Contact System)

Newest 38999 Style Connector



Plug



Receptacle

The OCS (Oval Contact System) is the newest 38999 Interconnect Product offering that provides many advantages for high speed data transmission.

OCS Mechanical/Physical Properties

- Mating Cycles 500 (min.)
- Operating temperature -65C to 175C
- Contact materials and platings consistent w/AS39029
- IR 500 VDC
- DWV 500 VAC rms

Max Current Rating:

- 1.5 amps inner contacts
- 3.0 amps outer contacts



Applications:

High Speed Applications-for use with, but not limited to, the following electrical protocols (Cable selection may limit data rate of protocols).

- 10G Base T
- HDMI
- Fibre Channel (AI)
- 40G Base-T
- SATA 2.0
- SATA 3.0 (limited to 3 meters max)
- Serial RapidIO
- PCI Express 3.0

Features and Benefits:

- A wide variety of insert arrangements available
- Patterns range from (1) to (21), 100 Ohm differential pairs capable of delivering data transfer speeds of 10Gbps per pair
- MIL-DTL-38999 shell styles available from size 9 to 25
- Front-release, rear-removable contact system for easy repair
- Meets environmental requirements of MIL-DTL-38999
- Uses off-the-shelf Mil Spec backshells
- PCB Tails contacts available, sockets only, epoxy backfilled.

OCS (Oval Contact System) Connectors

BTVContact Eye Pattern at 10 Gbps

OCS Signal Integrity Performance

Data rate: 10Gbps per pair
 Insertion loss: <0.3 dB up to 5 GHz
 Return loss: >20 dB up to 5 GHz
 NEXT and FEXT: >40 dB up to 5 GHz
 Differential to common mode conversion: >50 dB up to 5 GHz

Eye diagram (Real Part)

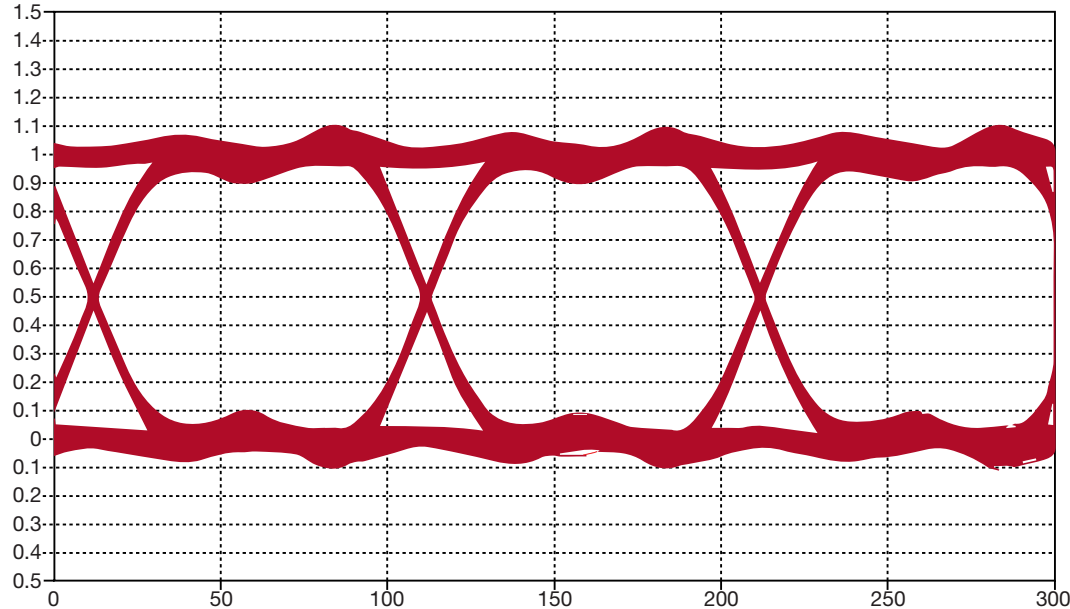

Individually Shielded Twinax cable is recommended for use with the OCS connectors. Other type of wires can be used, but will not be compatible with the rear accessory supplied with the connectors. Below is a list of recommended cables. Additional cables can be used if they meet specifications.

The provided grommet assembly will accommodate cable diameters ranging from Ø.124 to Ø.175. Larger diameters may work based on cable construction.

Impedance (Ohms)	Conductor (AWG)	Pairs	Cable Part Number
100	24	1	Tensolite 24463/9P025X-2(LD)
			Thermax MX100-24
			PIC E10224
			Gore GSC-05-82559-00 (space rated)
			Gore DXN2602
	24	4	Gore RCN 9034-24 (CAT6A Ethernet)*
	26	4	Gore RCN 9034-26 (CAT6A Ethernet)*
1		Spectra Strip 160-2699-952	

*Optimized for 13-53 insert pattern.

OCS cable assemblies available, please consult Amphenol Aerospace for details.

OCS (Oval Contact System) Connectors

How to Order

1. Connector Type and Shell Style	2. Service Class	3. Shell Size – Insert Arrangement	4. Contact Type	5. Alternate Keying Position	6. Suffix Code
TVP00	RZW	13 –53	P	B	(595)

1. Connector Type	
TVP00	Wall Mount Back panel mounted receptacle with metal shells
CTVP00	Wall Mount Back panel mounted receptacle with composite shells
TV06	Straight Plug
CTV06	Straight Plug composite shells
TV07	Jam Nut
CTV07	Jam Nut composite shells

3. Shell Size -Insert Arrangement	
Shell Size & Insert Arrangements are on pages 52. First number represents Shell Size, second number is the Insert Arrangement.	

4. Contact Type	
P	Pin contacts 21-033585-001
S	Socket contacts 21-033586-001

Inner contacts accept 28, 26, and 24 awg cable.

5. Alternate Keying Position	
A, B, C, D, and omit for Normal Position. See page 84 for more information.	

A plug with a given rotation letter will mate with a receptacle with the same rotation letter.

2. Service Class		
(Z) Threaded Backshell Style	(W) Integral Backshell Style*	Description
RZF	RWF	Electroless nickel plated
RGZF	RGWF	Electroless nickel plated ground plane
RZW	RWW	Olive drab cadmium plate
RGZW	RGWW	Olive drab cadmium plated ground plane
RZB	RWB	NiAlBronze
RGZB	RGWB	NiAlBronze ground plane
RZK	RWK	Corrosion resistance stainless steel
RGZK	RGWK	Stainless steel ground plane
ZDT	WDT	Durmalon plated, Nickel-PTFE alternative to cadmium
GZDT	GWDT	Groundplane Durmalon
ZDZ	WDZ	Black Zinc

6. Suffix code	
595	Space Grade
591	Space Grade with critical dimensions verified at 100%

Order information for Removal
Tool OCS Contact
10-6460C1-001

* Integral Backshell - an integral backshell style eliminates the need for costly backshell accessories, and allows the user to attach the shield of their cable directly to the backshell. The integral shell style also provides superior EMI shielding and ease for overmold applications.



For unused OCS connector cavities:

- Leave the contact insert cavity empty in the connector.
- Size 12 MS27488-12-2 (orange color) sealing plug can be installed into the grommet of the backshell large end first.



PCB
HD
Power
Bulk
Integral
Plug
Hermetic
Speed
Filter
Access
Tech

OCS (Oval Contact System) Connectors

Insert Arrangements - Front face of pins illustrated

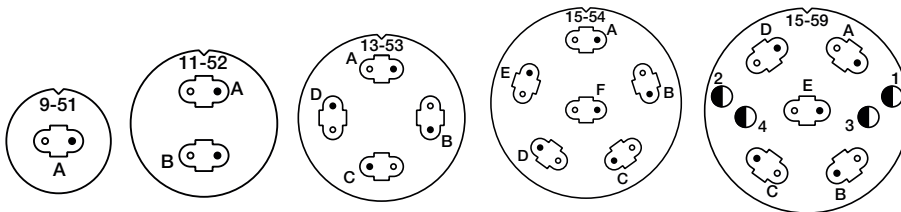

Insert Arrangement	9-51	11-52	13-53*	15-54	15-59*
Number of Contacts	1	2	4	6	5 OCS, 4 22D

38999 Insert Arrangements

The list is available patterns incorporating Octonet, Quadrax and Differential twinax contacts with D38999, Series III connectors. Unless otherwise stated, size 8 cavities can be filled with Quadrax or Differential Twinax contacts.

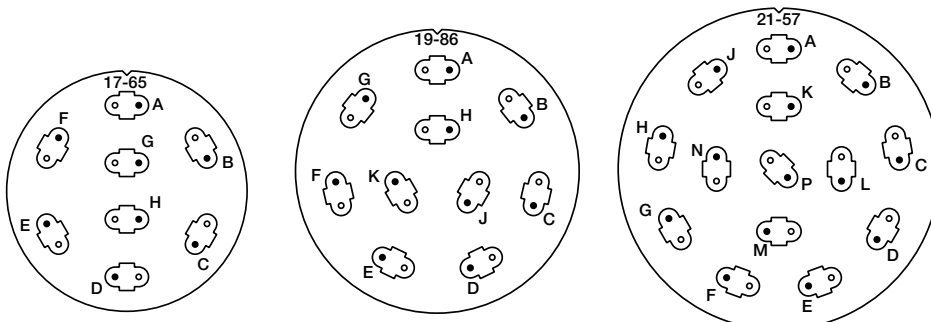

Insert Arrangement	17-65	19-86*	21-57*
Number of Contacts	8	10	14

Insert Arrangement Available

9-5
17-2
17-22
17-25
17-52
17-60
19-18
19-31
19-AB
19-AD
21-65
21-75
21-79
23-6
25-7
25-8
25-17
25-20
25-26
25-46
25-62
25-AT

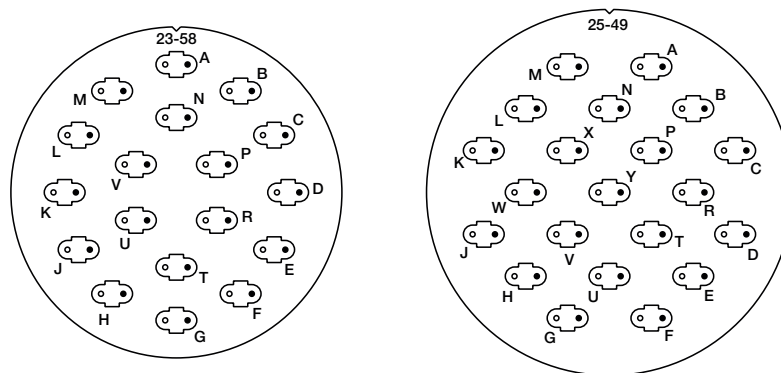

Insert Arrangement	23-58*	25-49*
Number of Contacts	18	21

* Indicates Insert currently tooled

• Designates pin 1 location within the OCS contact assembly

OCS (Oval Contact System) Connectors

TVP00 - Crimp, Metal & CTVP00 - Crimp, Composite Wall Mounting

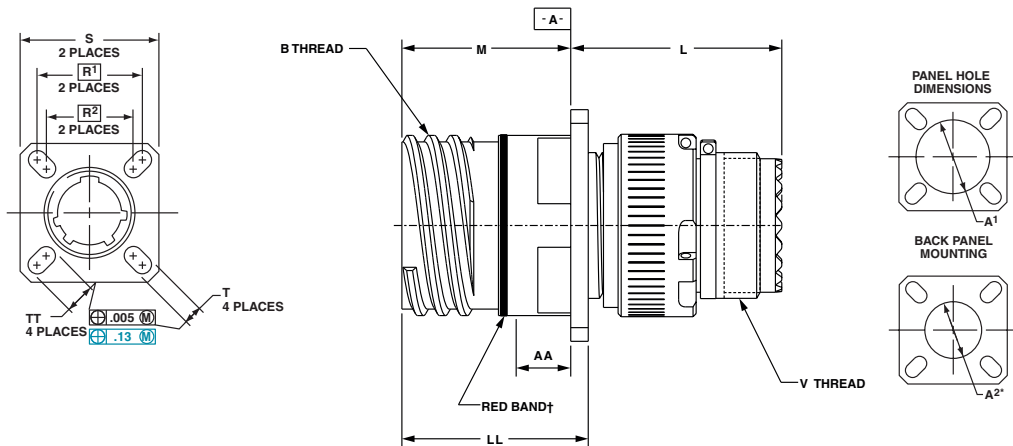

Shell Size	B Thread Class 2A 0.1P-0.3L-TS (Plated)	L Max. (TV)	L' Max. (CTV)	M +.000 - .005 (TV)	M' +.000 - .005 (CTV)	R ¹	R ²	S Max.	T ±.008	A ¹ Back Panel Mount	A ² Front Panel Mount	AA Max. Panel Thickness	LL +.006 - .000 (TV)	LL ±.005 (CTV)	TT ±.008	V Thread Metric
9	.6250	1.039	1.086	.820	.773	.719	.594	.948	.128	.655	.845	.234	.905	.908	.216	M12X1-6g
11	.7500	1.039	1.086	.820	.773	.812	.719	1.043	.128	.796	.963	.234	.905	.908	.194	M15X1-6g
13	.8750	1.039	1.086	.820	.773	.906	.812	1.137	.128	.922	1.081	.234	.905	.908	.194	M18X1-6g
15	1.0000	1.039	1.086	.820	.773	.969	.906	1.232	.128	1.047	1.239	.234	.905	.908	.173	M22X1-6g
17	1.1875	1.039	1.086	.820	.773	1.062	.969	1.323	.128	1.219	1.357	.234	.905	.908	.194	M25X1-6g
19	1.2500	1.039	1.086	.820	.773	1.156	1.062	1.449	.128	1.297	1.475	.234	.905	.908	.194	M28X1-6g
21	1.3750	1.069	1.118	.790	.741	1.250	1.156	1.575	.128	1.442	1.593	.204	.905	.904	.194	M31X1-6g
23	1.5000	1.069	1.118	.790	.741	1.375	1.250	1.701	.154	1.547	1.711	.204	.905	.904	.242	M34X1-6g
25	1.6250	1.069	1.118	.790	.741	1.500	1.375	1.823	.154	1.672	1.829	.204	.905	.904	.242	M37X1-6g

† Red band indicates fully mated * A2 dimensions are larger than standard D38999 dimensions to accommodate backshell. All dimensions for reference only.

OCS (Oval Contact System) Connectors

TV07R-Crimp, Metal & CTV07R-Crimp, Composite Jam Nut Receptacle

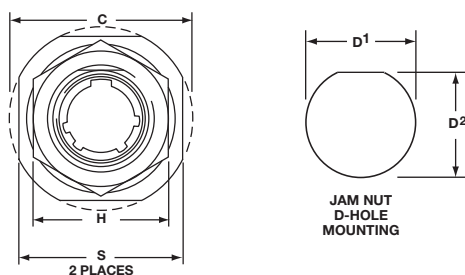

Shell Size	B Thread Class 2A 0.1P-0.3L-TS (Plated)	C Max.	D ¹ +.010 - .000	D ² +.000 - .010	H Hex +.017 - .016	K Ref.	S ±.010	V Thread Metric
9	.6250	1.199	.693	.657	.875	.871	1.062	M12X1-6g
11	.7500	1.386	.825	.770	1.000	.871	1.250	M15X1-6g
13	.8750	1.511	1.010	.955	1.188	.878	1.375	M18X1-6g
15	1.0000	1.636	1.135	1.085	1.312	.878	1.500	M22X1-6g
17	1.1875	1.761	1.260	1.210	1.438	.878	1.625	M25X1-6g
19	1.2500	1.949	1.385	1.335	1.562	.878	1.812	M28X1-6g
21	1.3750	2.073	1.510	1.460	1.688	.878	1.938	M31X1-6g
23	1.5000	2.199	1.635	1.585	1.812	.878	2.062	M34X1-6g
25	1.6250	2.323	1.760	1.710	2.000	.878	2.188	M37X1-6g

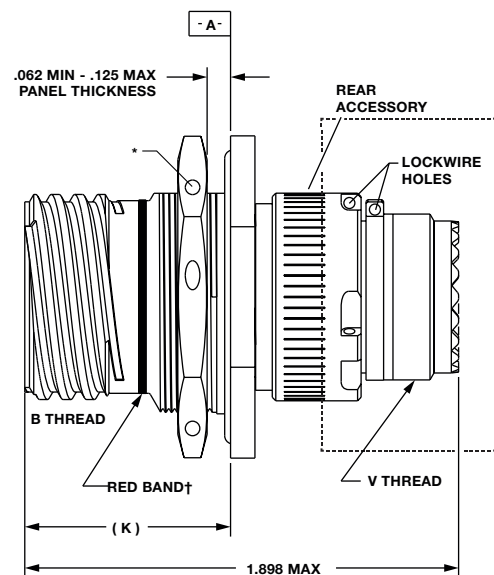

† Red band indicates fully mated
* .059 dia min., 3 lockwire holes, Formed lockwire hole design (6 holes) is optional

Quadrax Contacts



Typical Quadrax Socket Contacts

Has socket outer contact with a socket inner contact

Amphenol Quadrax Contacts

Offers several advantages for high data transfer rates, low power consumption, and excellent EMI compatibility. Four strategically spaced inner contacts form two 100 or 150 Ohm matched impedance differential pairs. The Outer contact has a rugged wall section for durability. Available in size 8 crimp termination style. Also available in size 8 with PC tails see online High-Speed Contact Product Guide. Requires modification of MIL-DTL-38999 connector to accommodate keyed contacts.

Cable Illustration - Quadrax Contact

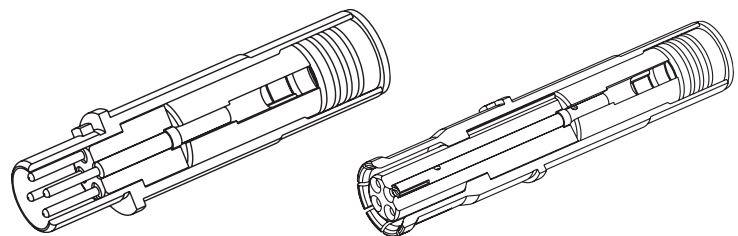
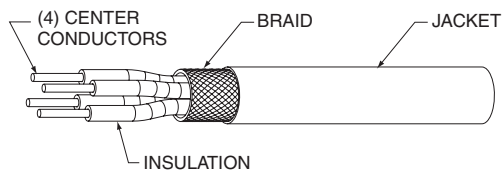

Quadrax Contacts are Gold Plated, Crimp Termination

Finish of mating contact parts: supplied with 0.000050 min. gold over nickel on mating interface.

Quadrax Size 8 Contact Performance:

Bandwidth: Up to 1.25 GHz
Data Rate: Exceeding 2.5 Gbps.
Voltage Rating: 500 Vrms max. @ sea level

Dielectric Withstanding Voltage:
1000 VAC rms between all inner contacts
@ sea level, 500 VAC rms between inner
and outer contacts @ sea level

Typical Quadrax Pin Contact:

Has pin outer contact with a pin inner contact

How to Order D38999, Series III Connectors with Standard 100 Ohm Quadrax Contacts

21-033385-051 Socket, 21-033384-051 Pin Contacts*

For all other quadrax contacts or differential twinax contacts, please consult Amphenol Aerospace for part numbers.

1.	2.	3.	4.	5.	6.
Connector Type	Shell Type	Service Class	Shell Size – Insert Arrangement	Contact Type	Alternate Keying Position
TVP	00	RQW	21-75	P	B

1. Connector Type	
TV	Tri-Start series connector with metal shells
TVP	Back panel mounted receptacle with metal shells
CTV	Tri-Start series connector with composite shells
CTVP	Back panel mounted receptacle with composite shells

6. Alternate Keying Position
A, B, C, D, and omit for normal rotation please see page 84 for more information.

2. Shell Style	
00	Wall mount receptacle
02	Box mount receptacle available only with the PCB tails and epoxy backfilled (non-removable)
06	Straight plug
07	Jam nut receptacle

3. Service Class with Quadrax	
RQF	Electroless nickel plated
RGQF	Electroless nickel plated ground plane
RQW	Olive drab cadmium plate
RGQW	Olive drab cadmium plated ground plane
RQK	Corrosion resistance stainless steel
RGQK	Stainless steel ground plane
QDT	Durmalon plated, Nickel-PTFE alternative to cadmium
GQDT	Groundplane Durmalon
QDZ	Zinc nickel black conductive
RQS	Stainless steel
JFW	Aluminum Bronze

4. Shell Size and Insert Arrangement
See insert arrangements available with Quadrax contacts on pages 75-83. First number represents shell size, second number is the insert arrangement.

5. Contact Type	
P	Pin contacts
S	Socket contacts

* The incorporation of Quadrax or Differential Twinax contacts requires a modified connector to accommodate keyed contacts.

Suggested Numbering for Quadrax Contacts

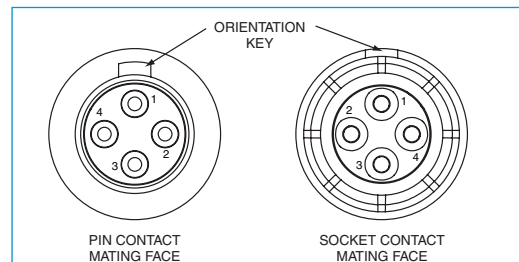

Differential Pairs, contacts 1-3, 2-4.
Quadrax differential pairs are 1 and 3, 2 and 4.

- PCB
- HD
- Power
- Bulk
- Integral
- Plug
- Hermetic
- Speed
- Filter
- Access
- Tech

Octonet Contacts

Superior Ethernet Contact System for MIL-DTL-38999, Series III



Eight strategically spaced inner contacts form four 100 Ohm matched impedance differential pairs.



Pin for 24 awg



Socket for 24 awg



Pin PCB Tail



Socket PCB Tail

Specs:

Environmental Sealing:	IAW connector specification
Corrosion Resistance:	500 hours salt spray
EMI Shielding:	360 degree shielding on each pair
Mating Cycles:	500 cycles
Voltage Rating:	500 Vrms max @ sea level
Dielectric Withstanding Voltage:	500 VAC RMS sea level

Features:

- Available in size 8 crimp termination style
- Can be installed in existing size 8 Quadrax cavities
- Meets performance specifications of CAT-6A cable
- 10G Ethernet compliant
- Overall higher bandwidth than standard CAT5E Quadrax-supports up to 4.0 Gbps per pair
- Enhanced crosstalk performance (compared to standard Quadrax)
- Supports wire ranges 26 to 24 gauge
- Requires modification of MIL-DTL-38999 connector to accommodate keyed contacts
- Operating Temp -65°C to 175°C
- Requires special backshell.
- Easy drop-in replacement to installed connectors
- Self removing contact feature - no extra contact extraction tool needed (24 Gauge only) no need to redesign

*Not limited to cables shown

Pin	Socket	*Cable	AWG
21-032904-001	21-032905-001	Thermax: MX10G-24HP	24
21-032904-011	21-032905-011	W.L.Gore: RCN8966-24	
21-032904-021	21-032905-021	PIC E6A3824, Harbour E10024065, E10024064	
21-032904-031	21-032905-031	W.L.Gore: GSC-03-84043-01	
21-032904-041	21-032905-041	Axon P542810	
21-032904-051	21-032905-051	PIC E6A6826	
21-032904-061	21-032905-061	Thermax MX10G-24FLX4	
PCB Pin	PCB Socket	L Dimension + or - 15	
21-032906-001	21-032907-001	Pin .884 / Socket 1.024	
21-032906-011	21-032907-011	.884	
21-032906-021	21-032907-021	.884	
21-032906-031	21-032907-031	.950	
21-032906-041	21-032907-041	.859	
21-032906-051	21-032907-051	.518	
21-032906-061	21-032907-061	.788	

finish table	
Prefix	Description
F2	Black Zinc Nickel
F4	Green Zinc Nickel
F7	Durmaol
F9	Thick OD Cadmium plate, Nickle Base
FH	Thick Electroless Nickel
FJ	Black Electroless Nickel

Length table	
Prefix	S ±.060
3	1.500
4	2.000
5	2.500
6	3.000
7	3.500
8	4.000
9	4.500

Note: it does not indicate stickout length when installed in D38999 connector.

PCB L dimension length given in chart is the distance from the rear of the contact retention shoulder to the tip of the PCB tails.

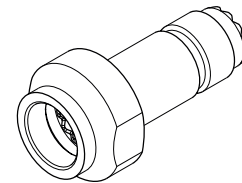
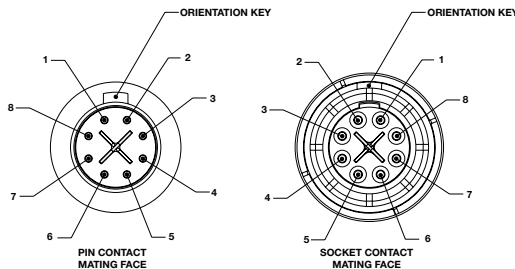
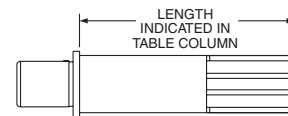

Backshell Extender

Due to the protusion of the Octonet Contacts through the rear of the grommet, a Backshell Extender must be used. The Extender is compatible with any Mil-Spec Backshell. Consult the factory for more information.

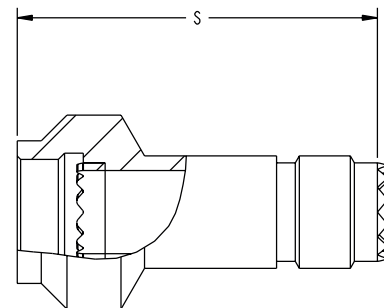

Part Number	Shell Size
FX-646409-01 ()	9
FX-646409-02 ()	11
FX-646409-03 ()	13
FX-646409-04 ()	15
FX-646409-05 ()	17
FX-646409-06 ()	19
FX-646409-07 ()	21
FX-646409-08 ()	23
FX-646409-09 ()	25

Signal Integrity Contact Data

Insertion and Return Loss

CONTACT DIFFERENTIAL INSERTION LOSS

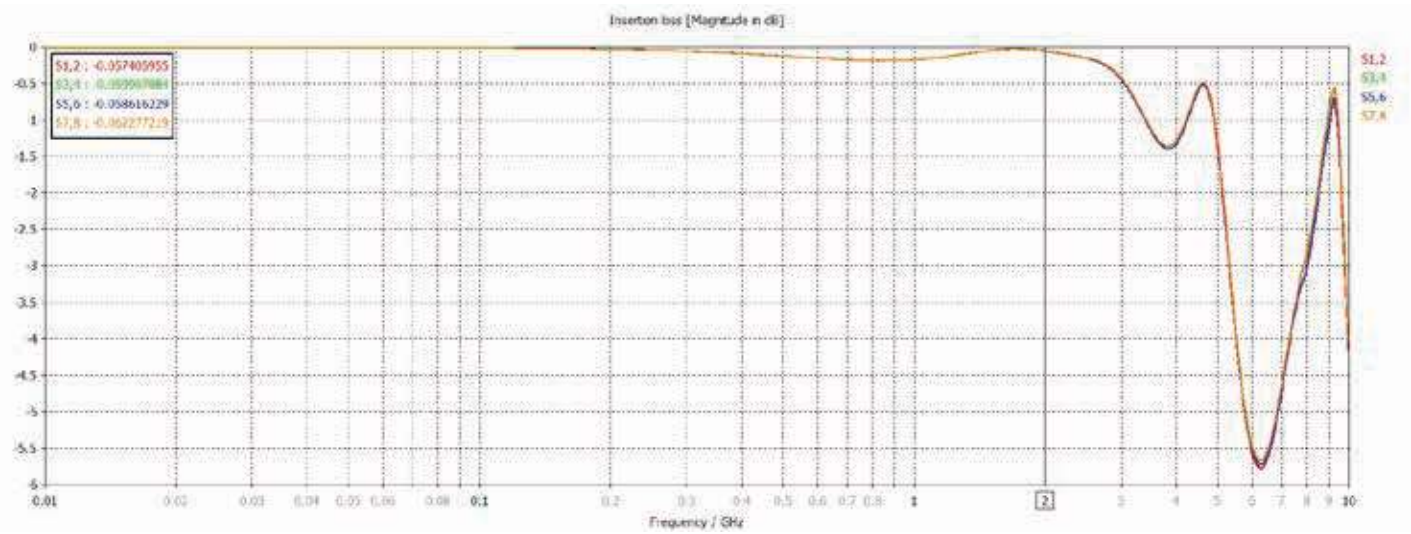

CONTACT DIFFERENTIAL RETURN LOSS

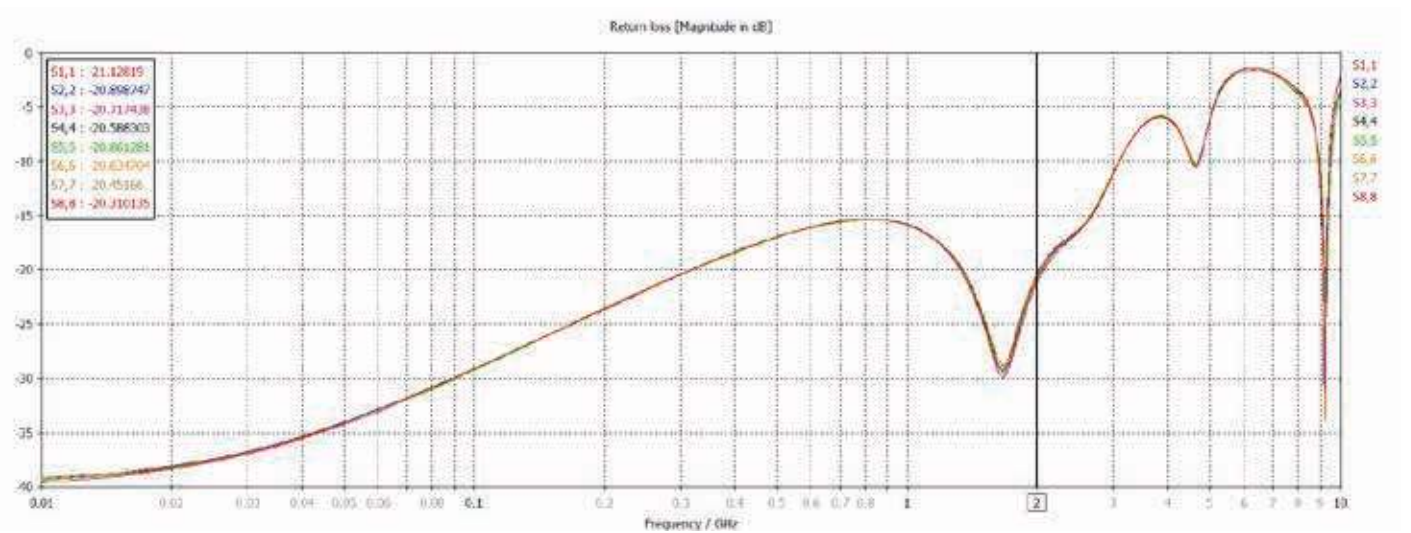

CONTACT DIFFERENTIAL REAR-END CROSSTALK

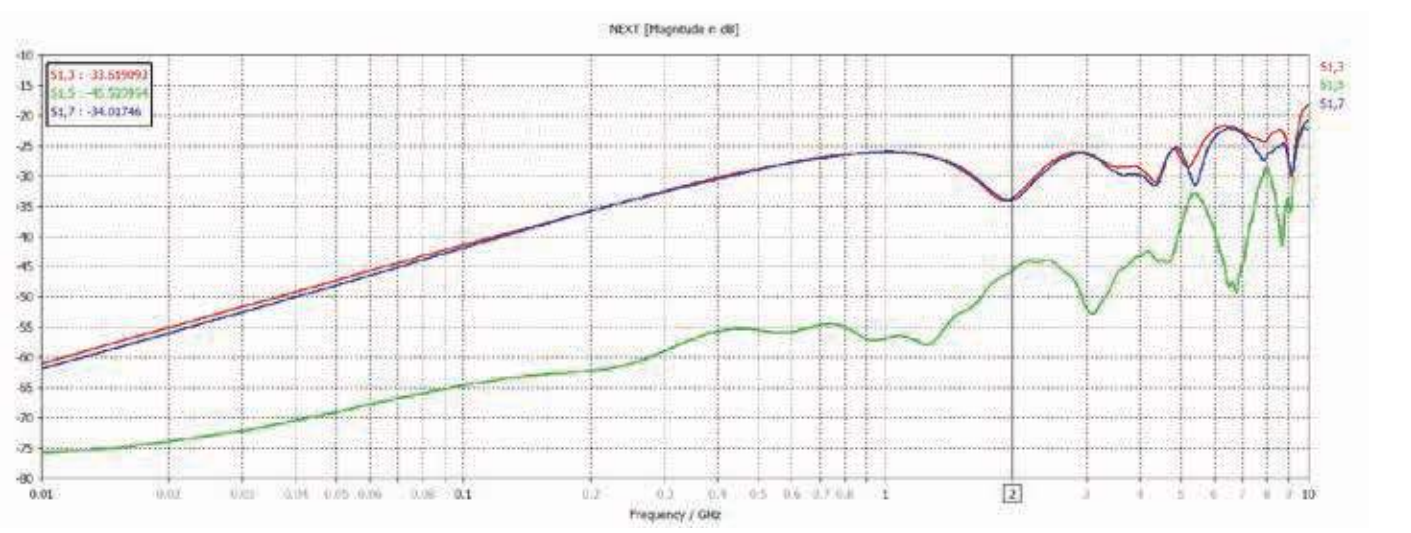

Tri-Start, Series III Fiber Optic Connectors

38999 Style



Our 38999 Fiber Optic connectors meets or exceeds MIL-DTL-38999 Series III requirements EMI Shielding-solid metal to metal coupling, grounding fingers, electroless nickel plating, and thicker wall sections provide superior EMI shielding capability of 65dB min. at 10 GHz. Termini Protection-recessed pins in this 100% scoop-proof connector minimize potential termini damage. Corrosion Resistance-shells of stainless steel or cadmium over nickel plating withstand 500 hr. salt spray exposure. Vibration/Shock-operates under severe high temperature vibration. Threaded coupling quickly and completely mates in one 360° turn of the coupling nut Amphenol.

Mechanical/Environmental:

Parameter	Performance
Maintenance Aging	MIL-STD-1344 Method 2002
Mating Durability	500 mating cycles
Insert Retention	100 PSI/25 lbs minimum
Sine Vibration	60 G (140-2000 Hz), 4 hours each at ambient, -55 deg C, and +175 deg C
Standard Shock	300 G half-sine, 3 ms duration
High Impact Shock	MIL-S-901 grade A with lightweight fixture
Temperature Life	1000 hours @ high temp rating
Thermal Shock	-55° C to +165° C - 5 cycles

This illustration shows the key features of the MIL-DTL-38999 CF-50- The highest optical performance connector.

1. Beryllium-copper retention clip for improved termini stability
2. Precision-aligned inserts
3. Modified master key
4. Integrated wave washer for improved performance in high vibration environments

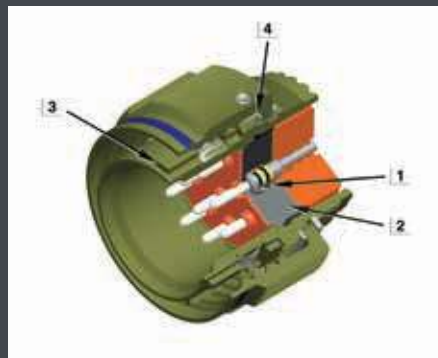

Multi Channel Fiber Optic Tri-Start

How to Order

Amphenol® Multi-Channel fiber optic connectors for use with multi-mode and single mode termini can be ordered by coded part number. Ordering procedure is illustrated by part number CF-509017-8P as shown below:

1.	2.	3.	4.	5.	6.
Connector Type	Series	Finish	Shell Style	Shell Size and Insert Arrangement	Contact Type and Key/Keyway Position
CF	50	9	0	17-8	p

1. Connector Type	
CF-	Multi-channel fiber optic

2. Series	
50	Aluminum, tight tolerance
60	Aluminum, tight tolerance
80	Stainless steel shell, tight tolerance

3. Finish	
4	Electroless nickel plated aluminum, 48 hour salt spray resistance, 200°C
5	Unplated composite
6	Corrosion resistant stainless steel, 500 hour salt spray resistance, 200°C
9	Corrosion resistant olive drab cadmium
D	Durmalon™ (Nickel-PTFE)

4. Shell Style	
0	Wall mount receptacle
1	Line receptacle
2	Box mount receptacle
6	Straight plug
7	Jam nut receptacle

5. Shell Size/Arrangement
09-94
09-98
11-2
11-5
11-98
11-99
13-4
13-8
13-13
13-98
15-5
15-15
15-18
15-19
15-97
17-8
17-26
17-99
19-11
19-28
19-32
21-16
21-29
21-39
21-41
23-21
23-53
23-54
23-55
25-4
25-11***
25-20***
25-24
25-26
25-29
25-37
25-41
25-43
25-46
25-61
25-90
25-F4

6. Contact Type and Key/keyway Position	
P	Pin contacts
S	Socket contacts

For more information on key/keyway rotation, see page 84, MIL-DTL-38999 Series III section.

For key/keyway positioning, choose the alternate rotation suffix letter from the chart below.

Alternate Position	Suffix Letter	
	Pins	Sockets
Normal	P	S
A	G	H
B	I	J
C	K	L
D	M	N
E	R	T

Fiber optic termini can be accommodated in any size 16 or size 20 contact cavity of MIL-DTL-38999 Series III type connector insert patterns, as listed in the following chart. See pages 73-80 for more information.

MT38999 Connectors and Fiber Optic Cable Assemblies

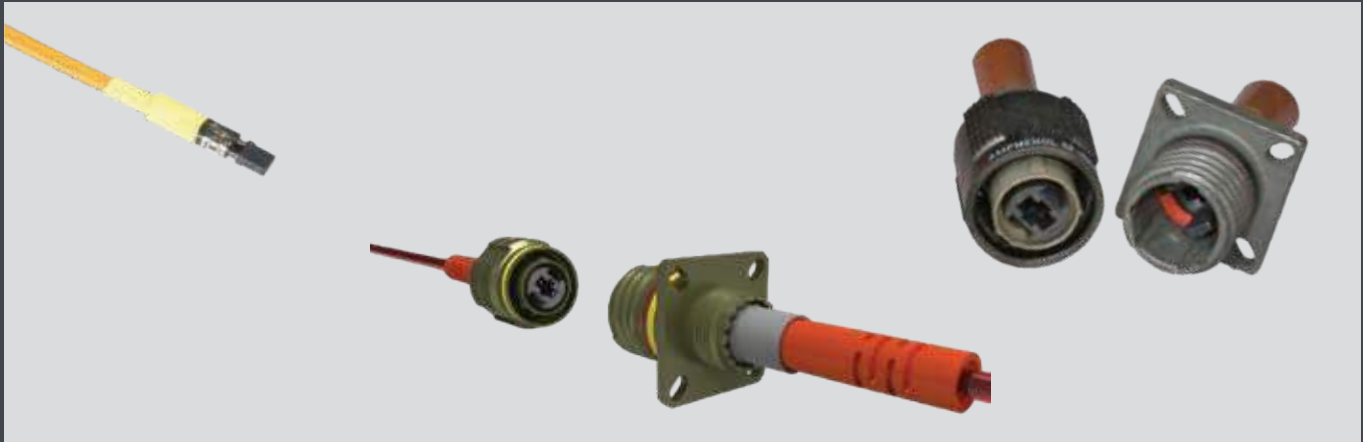

MT38999 Connectors

Amphenol MT 38999 Connectors are designed for high density fiber optic interconnect solutions.

Features:

- High fiber density in a relatively small circular connector package with all the advantages of the MIL-DTL-38999 series III connector
- Three levels of alignment provide for precision fiber to fiber interface:
 - Shell to shell with keying to allow for alternate positions
 - Insert plug to insert receptacle
 - MT contact guide pins
- Compatible with 12-fiber, 24-fiber, or 48-fiber MT ferrules in multi-mode PC single mode PC, and single mode APC configurations
- Two arrangements are available, shell size 11 with one ferrule, and shell size 21 with four ferrules
- Up to 48 fiber channels in a size 11 shell
- Up to 192 fiber channels in a size 11 shell

MT38999 Connectors

How to Order

1.	2.	3.	4.	5.	6.	7.
Connector Type	Connector Class	Terminus Style	Shell Finish	Shell Style	Shell Size- Insert Arrangement	Insert Type & Keyway Position
CF-	6	9	9	0	11-01	P

1. Connector Type	
CF-	Multi-channel fiber optic connector

2. Connector Class	
5	Aluminum
6	Composite
8	Stainless steel

3. Terminus Style	
9	MT terminus - Flat ribbon cable

4. Shell Finish	
4	Electroless nickel
6	Corrosion resistant stainless steel (connector class 8 only)
9	Olive drab cadmium
D	Durmalon™ (Nickel-PTFE)

Durmalon is a trademark of Amphenol Aerospace. For more information on Durmalon, go to amphenol-aerospace.com. Other shell finishes are available. Consult Amphenol Aerospace for more information.

MT Assembly Tool

Order Number: 11-100000-000



MT Removal Tool

Order Number: CF-008025-000

Optical / Mechanical / Environment

Parameter	Performance
Insertion Loss (850 nm)*	0.40 dB (typ)
Return Loss (850 nm)	-40.0 dB (typ)
Thermal Cycling	EIA-364-03D, test condition VII -40° to 85°C
Temperature Life	TIA/EIA-455-4; 85° for 336 hours
Vibration	MIL-STD-810F, Method 514.5
Mechanical Shock (Operational)	MIL-STD-810F, Method 516.5 75G half-sine, 10 ms duration
Mechanical Shock (Non-Operational)	MIL-STD-810F, Method 516.5 36-44G sawtooth, 10-12 ms duration
Humidity	TIA/EIA-455-5

* Values shown are typical. Optical loss performance dependant on optical launch conditions, end face geometry, end face quality, and grade of MT ferrule.

5. Shell Type	
0	Wall mount receptacle
1	Line receptacle
6	Straight plug
7	Jam nut receptacle

6. Select a Shell Size – Insert Arrangement		
	Shell Size-Insert Arrg	
Single cavity	11 - 01	
Four cavity	21 - 04	

MT Insert Availability
Front face of socket inserts illustrated

Alternate Position	Suffix Letter	
	Pins	Sockets
Normal	P	S
A	G	H
B	I	J
C	K	L
D	M	N
E	R	T

Insert Type and Keyway Position
P-designates pin insert, S-designates socket insert

MT Termini Assembly Kit

Amphenol supplies MT termini assemblies in kits, minus the MT ferrule. MT ferrules that meet the IEC1754-5 specification are recommended for use.

Kit Order Numbers

(MT Ferrules are not included with kit)

MT male assembly kit (flat ribbon): CF-198136-000

MT female assembly kit (flat ribbon): CF-198137-000

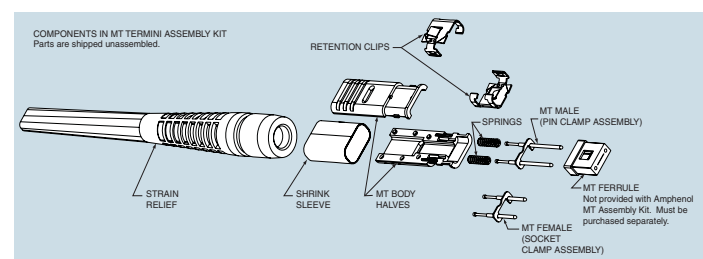

MT38999 Fiber Optic Cable Assemblies

How to Order

1.	2.	3.	4.	5.	6.
Fiber Optic Connector	Round Cable MT	Shell Finish	Shell Style	Shell Size –Insert Pattern	Alternate Position Suffix
CF-	5R	4	7	11-2	Blank for Normal

1. Fiber Optic Connector	
CF-	

2. Round Cable MT	
5R	

3. Shell Finish	
4	Electroless Nickel
9	Olive Drab
D	Durmalon

4. Shell Style	
0	Wall mount receptacle
1	In line receptacle
6	Straight plug
7	Jam nut

5. Shell Size - Insert Pattern	
Shell Size	Insert Pattern
11-2	2 Single MT Ferrule
21-4	4 Four MT Ferrules

6. Alternate Position Suffix		
Alternate Position	Suffix Letter	
	Pins	Sockets
Normal	P	S
A	G	H
B	I	J
C	K	L
D	M	N
E	R	T

MT38999 Fiber Optic Cable Assemblies:

Amphenol Aerospace offers the High Performance Interconnect Solution for your High Speed Needs.



Features and Benefits:

- Maneuverability
- Very high density in cylindrical connectors:
- Up to 48 fiber channels in size 11 shell
- Up to 192 fiber channels in size 21 shell

Round MT Cable Assemblies:

- From simple to complex
- Ruggedization with full testing (temperature, shock, vibration)
- Insertion loss and return loss testing capabilities
- Industry leading polish and termination capabilities
- Using COTS cable from across the country

PCB

HD

Power

Bulk

Integral

Plug

Hermetic

Speed

Filter

Access

Tech

38999 Filter Section



Being the original inventor of filter interconnects, Amphenol manufactures MIL-DTL 38999 Series III Filter Connectors, and are available in multiple versions, including many environmental-classes, with high and medium density insert arrangements. The “Tri-Start” mating thread makes them well suited to high-vibration and high-shock applications.

Amphenol’s Filter Connectors are available in several termination configurations, including PC tails, solder cups, and crimp contacts. They are also available with various plating and keying options, and are all intermateable with standard MIL-DTL-38999 Series III connectors.

Specifications Environmental

- Temperature Range: -55°C to 125°C
- Physical Shock: Typical to EIA-364-27
- Vibration: Typical to EIA-364-28
- Fungus Resistance: Based on MIL-STD-810
- Fluid Immersion: Typically tested to EIA-364-10
- Salt Spray: Typically based on EIA/ECA-364-26
- Humidity: Typically EIA-364-31 test method IV
- Durability: 1500 cycles for Classes J and M and 500 cycles for all other connectors as per 38999 spec

Electrical

- Grounded Line Resistance (Typ.): 30 mΩ max
- Insulation Resistance (Typ.): >10 GΩ
- Dielectric Withstand Voltage (Typ): 500 VDC
- Working Voltage (Typ): 200 VDC max
- Typical Test Specifications Used:
- Mil-STD-810: Test Method Standard
- Mil-STD-202: Electrical & Electrical Components Parts
- RTCA DO-160: Test Procedures for Airborne Equipment
- EIA-364: Electrical Connector & Socket Test Procedures

Reliable

- Triple-start, self-locking threaded coupling mechanism
- 100% scoop proof design
- Shell-to-Shell Continuity (ground strap between shells)

Filtering Capabilities

- Capacitance Range: 50 pF to 1.6 μF
- Capacitance Tolerance: Typically +/-20%
- Filtering Types Available: C, PI, LC, CL, T

Features Versatility:

- Wide range of connector shell configurations
- Configurable filter topologies

Designed for Harsh Environments:

- Vibration and shock
- Temperature extremes
- High humidity
- Altitude
- Salt spray

Mating Compatibility:

- MIL-DTL-38999 Series III connectors
- DEUTSCH DTS Series connectors
- DEUTSCH ACT Series composite connectors

How to Order - Standard

Filter Connectors

1.	2.	3.	4.	5.	6.	7.
Filter Connector Designator	Connector and Filter Type	Shell Finish	Shell Styles	Shell Size – Insert Arrg.	Type of Contact and Keyway Position	Printed Circuit Board Tail Length
21-	24	9	2	16-26	P	1

1. Connector Type	
21-	Filter Connector

3. Shell Finish	
0	Chromate
1	Bright cadmium
2	Stainless steel (electrolytic nickel plated)
4	Electroless nickel, MS (F)
7	Cadmium plate over nickel, MS(A)
8	Bright nickel
9	Cadmium plate, nickel base, OD, MS(B), (500 hr. salt spray test)
D	Durmalon™ Nickel-PTFE (cadmium alternative) - 38999 Class T refer to page 7
Z	Black Zinc

5. Shell Size and Insert Arrangement	
9 through 25	Shell sizes available for TV, Series III

Shell Size & Insert Arrangements are together in one chart. First number represents Shell Size, second number is the Insert Arrangement. See pages 75-83.

7. (Optional) This will change Connector to PCB Termination from default Solder Cup

Code	± .030	Pre-Tinned?
1	0.120	NO
2		YES
3	0.185	NO
4		YES
5	0.270	NO
6		YES

2. Connector/Filter Type	
50	FTV (UTS-crimp) with VHF-1 filter
51	FTV (UTS-crimp) with HF-1 filter (long shell)
52	FTV with VHF-1 filter
53	FTV with HF-1 filter (long shell)
76	FCTV with VHF-1 filter with composite shell
77	FTV with VHF-1 filter and standard series III shells
78	FCTV PCB mount with standard flange and VHF-1 filter
79	Same as 77 with no filter - Epoxy sealed
80	FTV PCB mount with standard flange, standard nut and VHF-1 filter
81	Same as 80 with no Filter - Epoxy sealed
82	FTV with ±8 volt diode/VHF-1 filter combination
84	FTV (UTS-crimp) with ±8 volt diode only
85	Same as 76 with no filter - Epoxy sealed

4. Shell Style	
0	Wall mount receptacle
2	Box mount receptacle
4	Minimum penetration jam nut receptacle
7	Jam nut receptacle

6. Type of Contact	
P	Pins in a normal rotation
S	Socket in a normal rotation

Alternate Rotation Suffix Letters

Alternate Position	FTV FCTV Suffix Letter	
	Pins	Sockets
Normal	P	S
A	G	H
B	I	J
C	K	L
D	M	N
E	R	T

Note:

-2XX Suffix

Any combination of filters, non-filters, grounds, and non-standard contact terminations will require -2XX suffix. Please consult Amphenol Aerospace for assistance in setting up these part numbers.

- Standard voltage for diode is ±8 volts. Any deviation requires a -2XX suffix.
- Standard voltage for a MOV is 47 volts. Any deviation requires a -2XX suffix.
- Standard diode/filter combination is ±8 volt/VHF-1 filter. Any deviation requires a -2XX suffix.
- Standard MOV/filter combination is 47 volt/VHF-1 filter. Any deviation requires a -2XX suffix.

Requesting Company: _____

End Customer: _____

Program/Application: _____

Date: _____

Mil-Spec Series or Style: Shell Size-Arrangement:

Customer Part ID:

Required Insertion Loss	
Frequency (MHz)	Enter Insertion Loss in db and either "min" or "max"
0.3	
1	
3	
10	
30	
100	
300	
1000	

Electrical Requirements

Filter Type	
<input type="checkbox"/> PI	<input type="checkbox"/> C
<input type="checkbox"/> CL	<input type="checkbox"/> T
<input type="checkbox"/> LC	<input type="checkbox"/> Casc PI

Capacitance	Nominal Capacitance (See Note 1)
Capacitance 1	
Capacitance 2	
Capacitance 3	

Working Voltage	
<input type="checkbox"/> 26 VDC	<input type="checkbox"/> 115VAC (RMS), 60 Hz
<input type="checkbox"/> 50 VDC	<input type="checkbox"/> 115VAC (RMS), 400 Hz
<input type="checkbox"/> 100 VDC	<input type="checkbox"/> Other
<input type="checkbox"/> 200 VDC	<input type="checkbox"/>

Insulation Resistance (Check the least)	
<input type="checkbox"/> >1 M-ohm	<input type="checkbox"/> >1 G-ohm
<input type="checkbox"/> >10 M-ohm	<input type="checkbox"/> >10 G-ohm
<input type="checkbox"/> >100 M-ohm	<input type="checkbox"/> Other: _____

Dielectric Withstanding Voltage	
<input type="checkbox"/> 100 VDC	<input type="checkbox"/> 500 VDC
<input type="checkbox"/> 200 VDC	<input type="checkbox"/> Other: _____

Transient Requirements	Transient Parameters
RTCA-DO-160	
MIL-STD-461	

Mechanical Requirements

Shell Style	
<input type="checkbox"/> Box Mount	<input type="checkbox"/> Adapter
<input type="checkbox"/> Jam Nut	<input type="checkbox"/> Plug
<input type="checkbox"/> Dual Flange	<input type="checkbox"/> Bulkhead Feedthrough
<input type="checkbox"/> Solder Mount	

Contact Termination	Stick out Dim. (From End of Shell)	Pre-tin (Y/N)
<input type="checkbox"/> PCB Tail		
<input type="checkbox"/> Solder Cup		
<input type="checkbox"/> Crimp Contacts		

Connector Mating Interface	Adapter Mating Interface
<input type="checkbox"/> Pins	<input type="checkbox"/> PS (Pin receptacle, socket plug)
<input type="checkbox"/> Sockets	<input type="checkbox"/> SP (Socket receptacle, pin plug)

Shell Finish	
<input type="checkbox"/> Durmalon (Nickel-PTFE, Cadmium alt.)	<input type="checkbox"/> Bright Nickel
<input type="checkbox"/> Cadmium Plate over Nickel (OD)	<input type="checkbox"/> Bright Cadmium
<input type="checkbox"/> Stainless Steel (Electrolytic nickel)	<input type="checkbox"/> Black Zinc
<input type="checkbox"/> Electroless Nickel	<input type="checkbox"/> Chromate
<input type="checkbox"/> Gold Plate over Nickel	<input type="checkbox"/>

Note 1: Capacitance can range from 50 pFd to 1.6 uFd, with a tolerance of +/-20%. Typical max capacitance spread within one connector is 10:1. Consult Amphenol with capacitance parameters outside of the specifications above.

Additional Comments:

Specific Requirements per Contact

If necessary, please indicate your individual pin filter requirements against the relevant contact number (or letter) below.

Contact Ref (s)	Filter Value Requirements: Feedthrough locations, Grounds, etc.	Contact Ref (s)	Filter Value Requirements: Feedthrough locations, Grounds, etc.	Contact Ref (s)	Filter Value Requirements: Feedthrough locations, Grounds, etc.	Contact Ref (s)	Filter Value Requirements: Feedthrough locations, Grounds, etc.
1 / A		48 / v		95		142	
2 / B		49 / w		96		143	
3 / C		50 / x		97		144	
4 / D		51 / y		98		145	
5 / E		52 / z		99		146	
6 / F		53 / AA		100		147	
7 / G		54 / BB		101		148	
8 / H		55 / CC		102		149	
9 / I		56 / DD		103		150	
10 / J		57 / EE		104		151	
11 / K		58 / FF		105		152	
12 / L		59 / GG		106		153	
13 / M		60 / HH		107		154	
14 / N		61 / II		108		155	
15 / O		62 / JJ		109		156	
16 / P		63 / KK		110		157	
17 / Q		64 / LL		111		158	
18 / R		65 / MM		112		159	
19 / S		66 / NN		113		160	
20 / T		67 / PP		114		161	
21 / U		68		115		162	
22 / V		69		116		163	
23 / W		70		117		164	
24 / X		71		118		165	
25 / Y		72		119		166	
26 / Z		73		120		167	
27 / a		74		121		168	
28 / b		75		122		169	
29 / c		76		123		170	
30 / d		77		124		171	
31 / e		78		125		172	
32 / f		79		126		173	
33 / g		80		127		174	
34 / h		81		128		175	
35 / i		82		129		176	
36 / j		83		130		177	
37 / k		84		131		178	
38 / l		85		132		179	
39 / m		86		133		180	
40 / n		87		134		181	
41 / o		88		135		182	
42 / p		89		136		183	
43 / q		90		137		184	
44 / r		91		138		185	
45 / s		92		139		186	
46 / t		93		140		187	
47 / u		94		141			



Connector Accessories



Amphenol offers a full range of accessories that are designed to enhance the performance of Amphenol 38999 connectors, both military and non-military.

Backshells are an integral part of any circular connector when it comes to reliable cable connections. Amphenol divisions team up globally to provide a very large assortment of backshells for use with 38999 Series of connectors, as well as other circular series.

The variety of types of backshells and adapters covered in the Backshells section of this catalog include:

- Non-environmental backshells
- Environmental backshells
- Non-environmental EMI/RFI backshells
- Environmental EMI/RFI backshells
- Shrink boot adapters
- Crimp ring adapters
- Band lock adapters
- Pre-shield adapters

MIL-DTL-38999, Series III TV

Receptacle Protection Cap

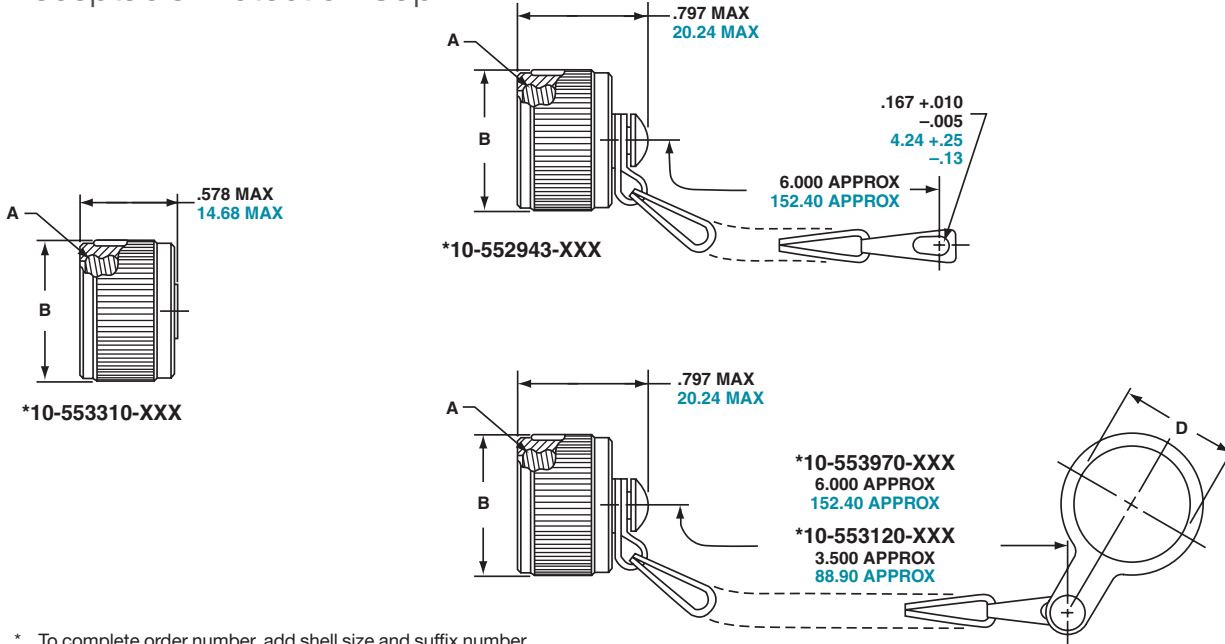

* To complete order number, add shell size and suffix number.
For example, shell size 11 with olive drab cadmium nickel base, 10-552943-119

Inches				Millimeters			
Shell Size	A Thread Class 2B 0.1P-0.3L-TS	B Dia. Max.	D Dia. +.010 - .000	Shell Size	MS Shell Size Code	B Dia. Max.	D Dia. +.25 - .00
9	.6250	.875	.703	9	A	22.23	17.86
11	.7500	1.000	.844	11	B	25.40	21.44
13	.8750	1.125	1.016	13	C	28.58	25.81
15	1.0000	1.250	1.141	15	D	31.75	28.98
17	1.1875	1.438	1.266	17	E	36.53	32.16
19	1.2500	1.500	1.391	19	F	38.10	35.33
21	1.3750	1.625	1.516	21	G	41.28	38.51
23	1.5000	1.750	1.641	23	H	44.45	41.68
25	1.6250	1.875	1.766	25	J	47.63	44.86

All dimensions for reference only.

TV Series III MS Metal Protection Caps

Shell Size	MS Shell Size Code	MS Receptacle Protection Cap
9	A	D38999/33W9X*
11	B	D38999/33W11X*
13	C	D38999/33W13X*
15	D	D38999/33W15X*
17	E	D38999/33W17X*
19	F	D38999/33W19X*
21	G	D38999/33W21X*
23	H	D38999/33W23X*
25	J	D38999/33W25X*

* To complete order number, replace X with applicable letter as follows:
R - designates eyelet type
N - designates washer type

MS metal protection caps are supplied with service class W which designates corrosion resistant olive drab cadmium plate aluminum.
Consult Amphenol Aerospace for more detailed information on ordering MS Metal protection caps.

Finish	10-No Suffix
Olive Drab, Cadmium, Nickel base	-XX9
Electroless Nickel	-XXG

Consult Amphenol Aerospace for availability of stainless steel protection caps, black zinc nickel, Durmalon, and other plating options.

TV Series III Plastic Protection Caps

Shell Size	Receptacle
9	10-70500-10
11	10-70500-12
13	10-70500-14
15	10-70500-16
17	10-70500-19
19	10-70500-20
21	10-70500-22
23	10-70500-24
25	10-70524-1

MIL-DTL-38999, Series III TV

Plug Protection Cap

- PCB
- HD
- Power
- Bulk
- Integral
- Plug
- Hermetic
- Speed
- Filter
- Access
- Tech

*10-552944-XXX

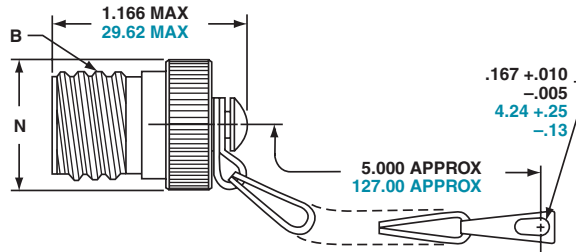

*10-553998-XXX

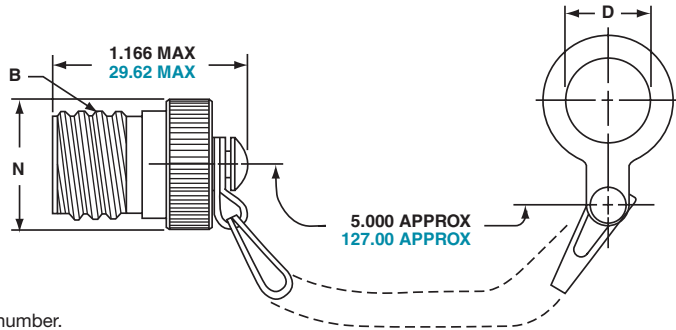

* To complete order number, add shell size and suffix number.
For example, shell size 11 with olive drab cadmium nickel base, 10-552944-119

Inches				Millimeters			
Shell Size	A Thread Class 2B 0.1P-0.3L-TS	D Dia. +.010 -.000	N Dia. Max.	Shell Size	MS Shell Size Code	D Dia. +.25 - .00	N Dia. Max.
9	.6250	.516	.895	9	A	13.11	22.73
11	.7500	.641	1.000	11	B	16.28	25.40
13	.8750	.766	1.171	13	C	19.46	29.74
15	1.0000	.891	1.299	15	D	22.63	32.99
17	1.1875	1.016	1.436	17	E	25.81	36.47
19	1.2500	1.141	1.543	19	F	28.98	39.19
21	1.3750	1.266	1.670	21	G	32.16	42.42
23	1.5000	1.343	1.787	23	H	34.11	45.39
25	1.6250	1.516	1.914	25	J	38.51	48.62

All dimensions for reference only.

TV Series III MS Metal Protection Caps

Shell Size	MS Shell Size Code	MS Plug Protection Cap
9	A	D38999/32W9X*
11	B	D38999/32W11X*
13	C	D38999/32W13X*
15	D	D38999/32W15X*
17	E	D38999/32W17X*
19	F	D38999/32W19X*
21	G	D38999/32W21X*
23	H	D38999/32W23X*
25	J	D38999/32W25X*

* To complete order number, replace X with applicable letter as follows:
R - designates eyelet type
N - designates washer type

MS metal protection caps are supplied with service class W which designates corrosion resistant olive drab cadmium plate aluminum.
Consult Amphenol Aerospace for more detailed information on ordering MS Metal protection caps.

Finish	10-No Suffix
Olive Drab, Cadmium, Nickel base	-XX9
Electroless Nickel	-XXG

Consult Amphenol Aerospace for availability of stainless steel protection caps, black zinc nickel, Durmalon, and other plating options.

TV Series III Plastic Protection Caps

Shell Size	Plug
9	10-70506-14
11	10-70506-16
13	10-70500-18
15	10-70500-20
17	10-70500-22
19	10-70500-24
21	10-70524-1
23	10-70506-28
25	10-70500-28

MIL-DTL-38999, Series III TV

Wall Mount Dummy Receptacle

- PCB
- HD
- Power
- Bulk
- Integral
- Plug
- Hermetic
- Speed
- Filter
- Access
- Tech

**PART NUMBER REFERENCE.
SEE NOTE BELOW TO COMPLETE.**

***10-553974-XXX**

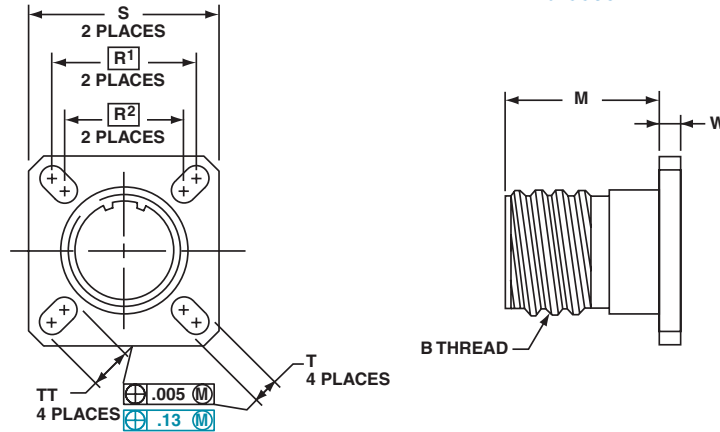

* To complete order number, add shell size and suffix number.
For example, shell size 11 with olive drab cadmium nickel base, 10-553974-119

Inches

Shell Size	MS Shell Size Coded	B Thread 0.1P-0.3L-TS (Plated)	M $\begin{matrix} +.020 \\ -.000 \end{matrix}$	$\boxed{R^1}$	$\boxed{R^2}$	S $\pm .010$	T $\begin{matrix} \pm .008 \\ -.006 \end{matrix}$	W $\pm .010$	TT $\begin{matrix} \pm .008 \\ -.006 \end{matrix}$
9	A	.6250	.822	.719	.594	.938	.128	.098	.216
11	B	.7500	.822	.812	.719	1.031	.128	.098	.194
13	C	.8750	.822	.906	.812	1.125	.128	.098	.194
15	D	1.0000	.822	.969	.906	1.219	.128	.098	.173
17	E	1.1875	.822	1.062	.969	1.312	.128	.098	.194
19	F	1.2500	.822	1.156	1.062	1.438	.128	.098	.194
21	G	1.3750	.791	1.250	1.156	1.562	.128	.125	.194
23	H	1.5000	.791	1.375	1.250	1.688	.154	.125	.242
25	J	1.6250	.791	1.500	1.375	1.812	.154	.125	.242

Millimeters

Finish	10-No Suffix
Olive Drab, Cadmium, Nickel Base	-XX9
Electroless Nickel	-XXG

Consult Amphenol Aerospace for availability of stainless steel protection caps, black zinc nickel, Durmalon, and other plating options.

Shell Size	MS Shell Size Coded	M $\begin{matrix} +.51 \\ -.00 \end{matrix}$	$\boxed{R^1}$	$\boxed{R^2}$	S $\pm .25$	T $\begin{matrix} +.20 \\ -.15 \end{matrix}$	W $\pm .25$	TT $\begin{matrix} +.20 \\ -.15 \end{matrix}$
9	A	20.88	18.26	15.09	23.83	3.25	2.49	5.49
11	B	20.88	20.62	18.26	26.19	3.25	2.49	4.93
13	C	20.88	23.01	20.62	28.58	3.25	2.49	4.93
15	D	20.88	24.61	23.01	30.96	3.25	2.49	4.93
17	E	20.88	26.97	24.61	33.32	3.25	2.49	4.93
19	F	20.88	29.36	26.97	36.53	3.25	2.49	4.93
21	G	20.09	31.75	29.36	39.67	3.25	3.18	4.93
23	H	20.09	34.93	31.75	42.88	3.91	3.18	6.15
25	J	20.09	38.10	34.93	46.02	3.91	3.18	6.15

All dimensions for reference only.

$\boxed{}$ Designates true position dimensioning.

MIL-DTL-38999, Series III TV

Jam Nut Dummy Receptacle

PCB

HD

Power

Bulk

Integral

Plug

Hermetic

Speed

Filter

Access

Tech

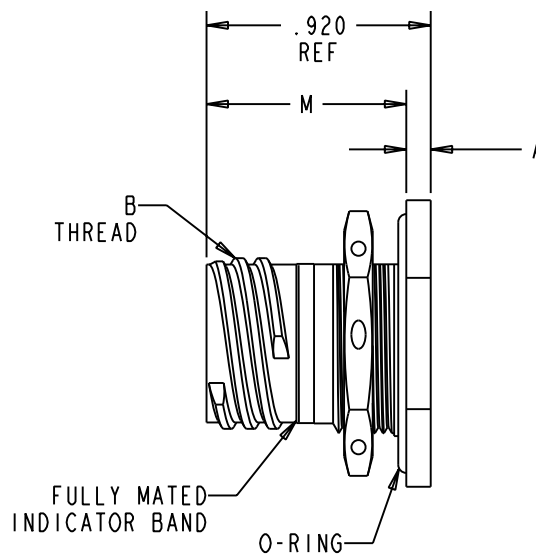
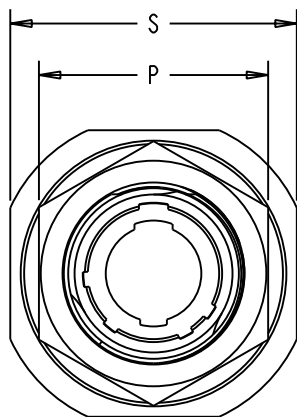

Inches

Shell Size	MS Shell Size Coded	A +.010 -.005	B Thread 0.1P-0.3L-TS (Plated)	M +.020 -.000	P Hex +.017 -.016	S +.011 -.010	RR Thread Plated 9-7543
9	A	.104	.6250	.871	.875	1.062	M17X1-6g 0.100R
11	B	.104	.7500	.871	1.000	1.250	M20X1-6g 0.100R
13	C	.104	.8750	.878	1.188	1.375	M25X1-6g 0.100R
15	D	.104	1.0000	.878	1.312	1.500	M28X1-6g 0.100R
17	E	.104	1.1875	.878	1.438	1.625	M32X1-6g 0.100R
19	F	.135	1.2500	.878	1.562	1.812	M35X1-6g 0.100R
21	G	.135	1.3750	.878	1.688	1.938	M38X1-6g 0.100R
23	H	.135	1.5000	.878	1.812	2.062	M41X1-6g 0.100R
25	J	.135	1.6250	.878	2.000	2.188	M44X1-6g 0.100R

MIL-DTL-38999, Series III TV

Universal “Header Assembly” for Flex Print or PC Board

Mounts to all MIL-DTL-38999

The universal header assembly from Amphenol provides for easy separation of the connector from the board.

The header assembly is comprised of a short pin/socket contact. The tail end of the contact is soldered to the through hole of the flex or printed circuit board. The socket is embedded in the insulator, making electrical contact with the printed circuit tail of the connector.



Headers provide easy separation of the connector from the PC board.

Features and Benefits:

- Circular and square header assemblies available
- Cost and time savings in the manufacturing process
- Assemblies can be vapor phase or wave soldered to flex/printed circuit board
- Allows electrical testing when installed properly.
- Connector assemblies can be easily removed from and reattached to the header assembly.

Mounting Applications

- Amphenol **square** universal headers are slotted to allow mounting to all series of MIL-DTL-38999 connectors without special alterations.
- Amphenol **circular** universal headers are designed to accommodate the rear flange of PCB Board Mount shells, series MIL-DTL-38999 connectors without special alterations.
- The header assembly can be attached to connectors with standard flange placement or directly to the circuit board.
- Connectors with dual flange mounting hardware can be provided to allow easy mounting to the panel or the header assembly.
 - Forward flange would mount the connector to the panel
 - Rear flange would be used to mount to the header assembly.
- Various types of captivated or loose attaching screws can be utilized for unique applications.

Mounting to Rectangular ARINC Connectors

- Headers for ARINC connector arrangements accommodate up to 150 pins
- Consult Amphenol Canada, Ontario for ARINC configurations.

Materials

- Body is molded or machined from FR-4.
- Electrical engagement areas of the header contact are plated with .00003 inches minimum of gold over .00005 inches minimum of nickel.

See drawing of standard header on next page.

PCB

HD

Power

Bulk

Integral

Plug

Hermetic

Speed

Filter

Access

Tech

MIL-DTL-38999, Series III TV

Universal "Header Assembly" for Flex Print or PC Board

The drawing below shows the standard header assembly for use with MIL-DTL-38999 connectors.

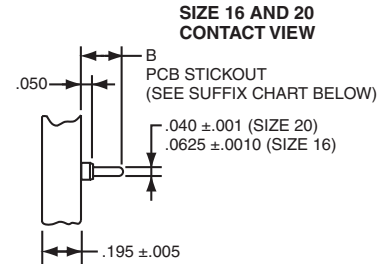
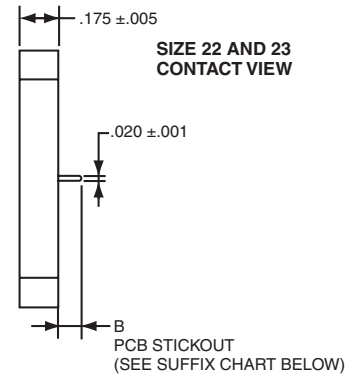
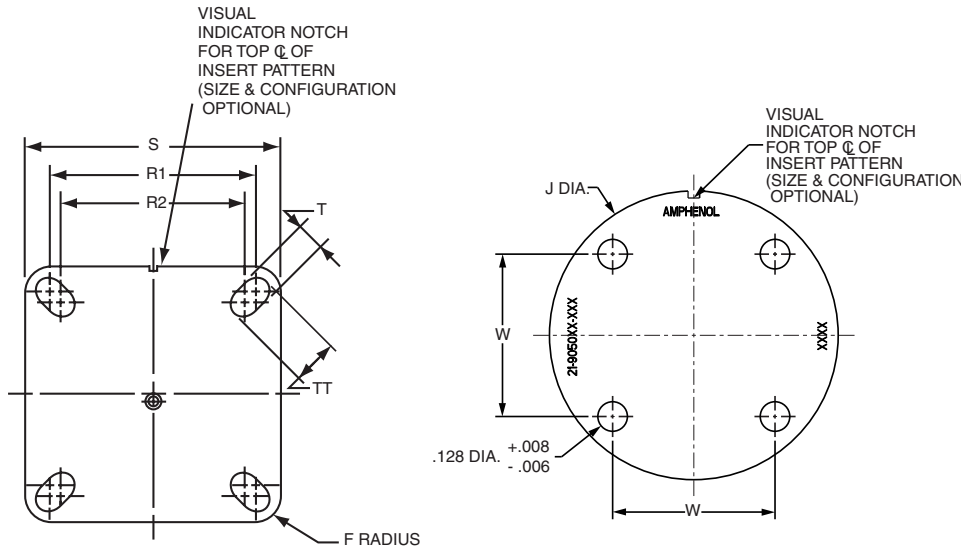

NOTE:
 Size 16 accepts .048 to .064 dia. PCB tails.
 Size 20 accepts .037 to .043 dia. PCB tails.
 Size 22 & 23 accepts .018 to .022 dia. PCB tails

Square Assembly Part Number	Shell Size	F Radius	S ± .005	T + .008 - .006	R1 TP†	R2 TP†	TT + .008 - .006
21-904008-XX()	9	.094	.938	.128	.719	.594	.216
21-904010-XX()	11	.094	1.031	.128	.812	.719	.194
21-904012-XX()	113	.094	1.125	.128	.906	.812	.194
21-904014-XX()	15	.125	1.219	.128	.969	.906	.173
21-904016-XX()	17	.125	1.312	.128	1.062	.969	.194
21-904018-XX()	19	.125	1.438	.128	1.156	1.062	.194
21-904020-XX()	21	.125	1.562	.128	1.250	1.156	.194
21-904022-XX()	23	.125	1.688	.154	1.375	1.250	.242
21-904024-XX()	25	.125	1.812	.154	1.500	1.375	.242

† TP designates true position dimensioning.

Circular Assembly Part Number	Shell Size	J Dia. ± .005	W
21-905008-XX()	9	1.016	.532
21-905010-XX()	11	1.062	.601
21-905012-XX()	13	1.250	.703
21-905014-XX()	15	1.375	.791
21-905016-XX()	17	1.500	.875
21-905018-XX()	19	1.625	.975
21-905020-XX()	21	1.750	1.053
21-905022-XX()	23	1.875	1.145
21-905024-XX()	25	2.000	1.233

How to Order Information For Header Assembly with MIL-DTL-38999 Connectors

1. Series	2. Type	3. Shell Size & Insert Arrg.	4. PCB Suffix
21-	9040	8-3	1

1. Series		2. Type	
21-	Header Assembly	9040	Square
		9050	Circular

3. Shell Size and Insert Arrangement

See insert arrangements available with Quadrax contacts on pages 75-83. First number represents shell size, second number is the insert arrangement. See MIL-STD-1560 document for coordinates of inserts.

* Shell size designation for MIL-DTL-38999

4. Contact PCB Stickout

Suffix	Shell Size*	Contact PCB Stickout Length
		B ± .015 Stickout
1	08	.120
1	09	.120
2	10	.185
3	12	.270
NA	14	
NA	15	
2	16	.185
3	16	.270
	18	
2	20	.185
3	20	.270
1	22	.120
2	22	.185
3	22	.270
1	23	.120
	24	
	25	

MIL-DTL-38999, Series III TV, HD

Insert Availability and Identification Chart

TV III	Crimp	Hermetic TV*	Service Rating	Total Contacts	Contact Size										
					23 HD	22D	22M	22	20	16	12	12 (Coax)	8 (Coax)	8†† (Twinax)	
9-5*			Grounded	1											1
9-9	X		N	9	9										
9-35	X	P	M	6		6									
9-94	◆		M	2					2						
9-98	X	P	I	3					3						
11-2*	X		I	2						2					
11-4	2		I	4					4						
11-5	X	P	I	5					5						
11-19			N	19	19										
11-35	X	P	M	13		13									
11-54	X		II	4		4									
11-98	X	P	I	6					6						
11-99	X	P	I	7					7						
13-4*	X	P	I	4						4					
13-8	X	P	I	8					8						
13-13	◆		I, Fiber Optic	4						2**	2				
13-26	2		M	8		6					2				
13-32	◆		N	32	32										
13-35	X	P	M	22		22									
13-63	◆		I	4						2	2				
13-98	X	P	I	10					10						
15-AT	X		I	13		10					3				
15-4	◆		I	4							4				
15-5*	X	P	II	5						5					
15-15	X	P	I	15					14	1					
15-18	X	P	I	18					18						
15-19	X	P	I	19					19						
15-35	X	P	M	37		37									
15-55	◆		N	55	55										
15-97	X	P	I	12					8	4					
17-2	X	◆	M	39		38									1
17-EA	◆		M	19		10			3	2	4				
17-EC	◆		M	41		32			9						
17-6	X	P	I	6							6				
17-8*	X	P	II	8						8					
17-22*	◆		Coax	4								2	2		
17-25	2		M	24		22							2		
17-26	X	P	I	26					26						
17-35	X	P	M	55		55									
17-52	X ◆		M	2											2
17-60	X		I/Coax	10		8							2		
17-73	X		N	73	73										
17-99	X		I	23					21	2					
19-AD	X ◆		Inst.	17					16						1
19-FA	◆		M	23		6			8	7	2				
19-11*	X	P	II	11						11					
19-18	2		M	18		14									4
19-28	X		I	28					26	2					
19-31	X		M	15		12					1		2		
19-32	X	P	I	32					32						
19-35	X	P	M	66		66									
19-68	X		I	18						18					

PCB
HD
Power
Bulk
Integral
Plug
Hermetic
Speed
Filter
Access
Tech

MIL-DTL-38999, Series III TV, HD

Insert Availability and Identification Chart

- PCB
- HD
- Power
- Bulk
- Integral
- Plug
- Hermetic
- Speed
- Filter
- Access
- Tech

TV III	Crimp	Hermetic TV*	Service Rating	Total	Contact Size															
					23 HD	22D	22M	22	20	16	16 (Coax)	12 (Pwr)	12 (Coax)	10 (Power)	8 (Power)	8 (Coax)	8†† (Twinax)	8 Quadrax	4	
19-88■	X		N	88	88															
21-11*	X		I	11								11								
21-16*	X	P	II	16																
21-29	X		I	27						19	4		4							
21-35	X	P	M	79		79														
21-39	X	P	I	39						37	2									
21-41	X	P	I	41						41										
21-48■	X		M	4											4					
21-75*◇	X		M	4												4	(4)			
21-79■	X		II	19		17										2	(2)			
21-121■	X		N	121	121															
23-6*■	X		M	6														6		
23-14■	◆		I	14								14								
23-21*	X	P	II	21						21										
23-35	X	P	M	100		100														
23-53	X	P	I	53					53											
23-54■	X		M	53		40			9		4									
23-55	X	P	I	55					55											
23-63■	S		M	57		49					4		4							
23-151■	X		N	151	151															
25-4	X	P	I	56					48	8										
25-7	X		Twinax	99		97										2				
25-8*	◆		Twinax	8													8			
25-11***	◆		N	11					2					9						
25-16■	◆		M	8					6											2
25-17■	◆		M	42		36												6		
25-19*	X	P	I	19								19								
25-20***	◆		N	30					10	13			4					3		
25-24*	X		I	24						12		12								
25-26■*	F		I	25					16			5				4				
25-29*	X		I	29						29										
25-35	X	P	M	128		128														
25-37*	X		I	37						37										
25-41■		N	Inst.	41		22			3	11			2					3		
25-43	◆		I	43					23	20										
25-46	◆		I	46					40	4					2					
25-61	X	P	I	61					61											
25-62■*	X	◆	I	12						8									4	
25-88*	◆		Twinax/ Coax	8											8					
25-90	◆		I	46					40	4								2		
25-187■	X		N	187	187															
25-1A■			N	8						4										4
25-AT■	X		M	60		31			12	13			2	2				2		
25-F4■	X		M/I	66		49				13			4							

- X Completely tooled.
- ◆ Not tooled for 02-R.
- P Available with Pin contacts only
- S Available with Socket contacts only
- P/S Available with Pin contacts or Socket contacts
- * Ground plane proprietary option available. Arrg. 9-5 is exclusively ground plane type.
- Not Mil-Qualified.
- ◇ 21-75 is Mil-Qualified with twinax contacts only.
Note: MS connector 21-75 is supplied with size 8 twinax.
Commercial connector 21-75 is supplied with size 8 coax.

- HD designates High Density 38999 Series III insert patterns which use size 23 contacts only. Not rated over 175°C.
- * Hermetic inserts - solder termination standard. (Contact Amphenol Aerospace for optional PCB or eyelet termination).
- ** Two size 16 contacts dedicated to fiber optics. See the Fiber Optic section for more information.
- *** For use in MIL-STD-1760 applications (see pages 75 and 76).
- † For RG 180/U and RG 195/U cables only.
- †† Size 8 Coax and Twinax are interchangeable.
- (2) Not Tooled for RP or 02RE
- (3) Pin inserts only, not tooled for RP or 02RE (Consult Amphenol Aerospace for avail.)
- (5) MS Connector 21-79 has provision for two size 8 coax contacts. Coax contacts are not supplied unless specified by customer.

MIL-DTL-38999, Series III TV, HD

Insert Availability and Identification Chart

Select Shell Size - Special Insert Arrangement (Not Mil-Spec Qualified)

Shell Size-Insert Arrg.	Crimp	Hermetics*	Service Rating	Total Contacts	Comments	Contact Size			
						22D	20	16	12
9-2	X		I	2	Formerly Pyle		2		
15-4	X		II	4	Formerly Pyle			4	
15-25	X		M	25	Formerly Pyle	22		3	
17-20	X		M	20	Formerly Pyle	16			4
21-12	X		I	12	Formerly Pyle		3		9
21-21	X		M/Inst.	41	Improved sealing	32			9
21-99	X		M	16	Formerly Pyle	5			11
25-92	X		M	101	Formerly Pyle	92		9	
25-97	X		M	42	Formerly Pyle	26		3	13

Shell Size-Insert Arrg.	Crimp	Service Rating	Total Contacts	Contact Size				
				22D	20	8	4	0
25L-3	X	II	3			1	2	
25L-7	X	II	7			7		
33-3	X	II	3				1	2
33-5	X	II	5				5	
33-6	X	II	6			2	4	
37-5	X	II	4					4

Select Non-Standard Shell Size
- Special Insert Arrangement, contact Amphenol Aerospace for connector dimensional information

Common Modification Options

(Contact Amphenol for more options)

Modification Description	Mod Code	Plug	Jam Nut	Wall Mount
Power contacts to replace coax/twinax	(PWR)	√	√	√
Deep Reach Version	(DPR)		√	√
Radsok Contacts	(RDS)	√	√	√
Temper Grip Contacts	(B65)	√	√	√
Outgassing (Space Grade)	(453)	√	√	√
5-Web Grommet Enhanced Sealing	(539)	√	√	√
AmpheSeal	(737)	√	√	√
High Vibration Plug - "RotoLok"	(474)	√		
Wing Nut Plug for Gloved Applications	(734)	√		
Spanner Nut in place of Hex Nut	(730)		√	
Jet Fuel Resistance	(481)	√	√	√
EMI Conductive O-Ring	(735)		√	
Compliant Pins/Press Fit Contacts	See AAO for details		√	√
First Mate Last Break Contacts	See AAO for details	√	√	√
Thermocouple Contacts	See AAO for details	√	√	√
Solder Cup Contacts	See AAO for details	√	√	√
Right Angle PCB Contacts	See AAO for details		√	√

PCB

HD

Power

Bulk

Integral

Plug

Hermetic

Speed

Filter

Access

Tech

MIL-DTL-38999, Series III TV, HD

Insert Arrangements

Front face of pin inserts illustrated

PCB

HD

Power

Bulk

Integral

Plug

Hermetic

Speed

Filter

Access

Tech

Shell Size & Insert Arrg. for:

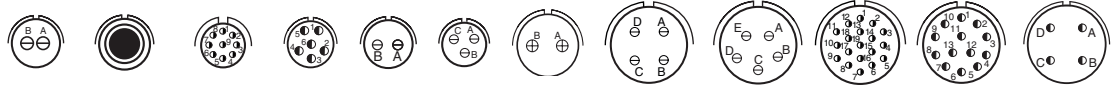

Series III TV	9-2	9-5	9-9 HD	9-35	9-94	9-98	11-2	11-4	11-5	11-19 HD	11-35	11-54
Service Rating	I	Grounded	N	M	M	I	I	I	I	N	M	II
Number of Contacts	2	1	9	6	2	3	2	4	5	19	13	4
Contact Size	20	8 Twinax	23	22D	20	20	16	20	20	23	22D	22D

Shell Size & Insert Arrg. for:

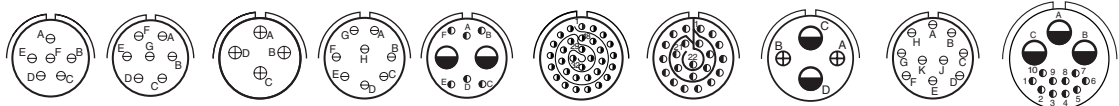

Series III TV	11-98	11-99	13-4	13-8	13-26	13-32 HD	13-35	13-63	13-98	15-AT		
Service Rating	I	I	I	I	M	N	M	I	I	I		
Number of Contacts	6	7	4	8	6	2	32	2	2	10	10	3
Contact Size	20	20	16	20	22D	12	23	16	12	20	22D	12

Shell Size & Insert Arrg. for:

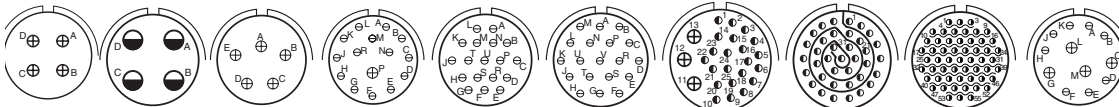

Series III TV	15-4*	15-4	15-5	15-15	15-18	15-19	15-25	15-35	15-55 HD	15-97			
Service Rating	II	I	II	I	I	I	M	M	N	I			
Number of Contacts	4	4	5	14	1	18	19	22	3	37	55	8	4
Contact Size	16	12	16	20	16	20	20	22D	16	22D	23	20	16

Shell Size & Insert Arrg. for:

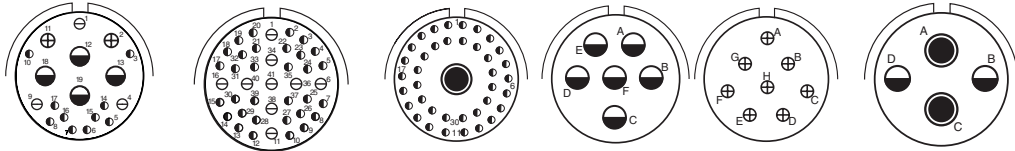

Series III TV	17-EA	17-EC	17-2	17-6	17-8	17-22						
Service Rating			M	I	II	Coax						
Number of Contacts	10	3	2	4	32	9	38	1	6	8	2	2
Contact Size	22D	20	16	12	22D	20	22D	8 Twinax	12	16	12 Coax	8 Coax

Shell Size & Insert Arrg. for:

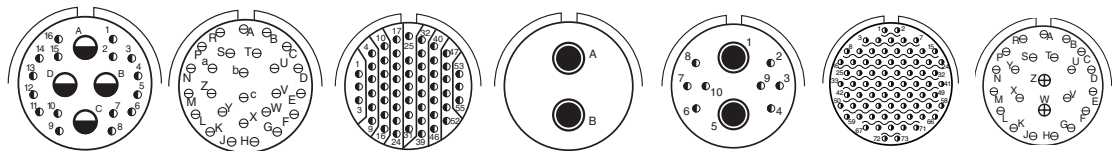

Series III TV	17-20	17-26	17-35	17-52	17-60	17-73 HD	17-99	
Service Rating	M	I	M	M	I/Coax	N	I	
Number of Contacts	16	4	26	55	8	2	21	2
Contact Size	22D	12	20	22D	8	2	20	16
					22D	8	23	
					Coax	23		

HD: High Density HD38999 (use size 23 contacts only)

CONTACT LEGEND

8	10	12	16	20	22	22M	22D	23

MIL-DTL-38999, Series III TV, HD

Insert Arrangements

Front face of pin inserts illustrated

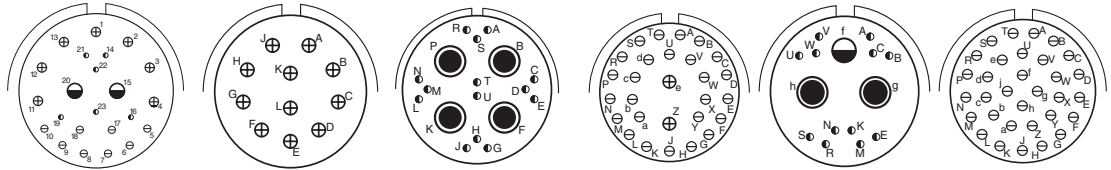

Shell Size & Insert Arrg. for:

Series III TV	19-FA				19-11	19-18		19-28		19-31			19-32
Service Rating	M				II	M		M		M			1
Number of Contacts	6	8	7	2	11	14	4	26	2	2	1	12	32
Contact Size	22D	20	16	12	16	22D	8 Twinax	20	16	8	12	22D	20
										Coax			

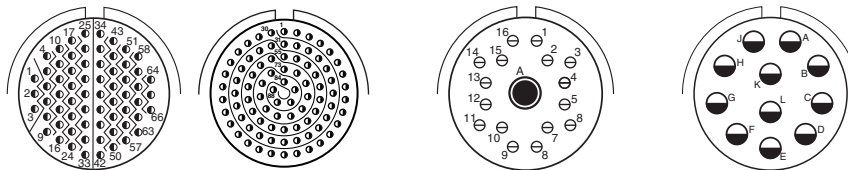

Shell Size & Insert Arrg. for:

Series III TV	19-35	19-88 HD	19-AD	21-11
Service Rating	M	N	Inst.	I
Number of Contacts	66	88	16	11
Contact Size	22D	23	20	12
			8 Twinax	

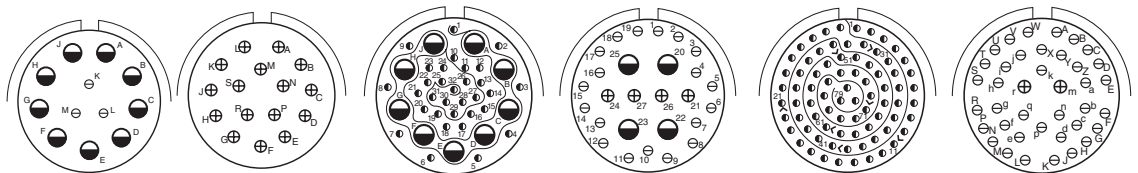

Shell Size & Insert Arrg. for:

Series III TV	21-12		21-16	21-21		21-29			21-35		21-39	
Service Rating	I		II	M/Inst.		I			M		1	
Number of Contacts	3	9	16	32	9	19	4	4	79	37	2	
Contact Size	20	12	16	22D	12	20	16	12	22D	20	16	

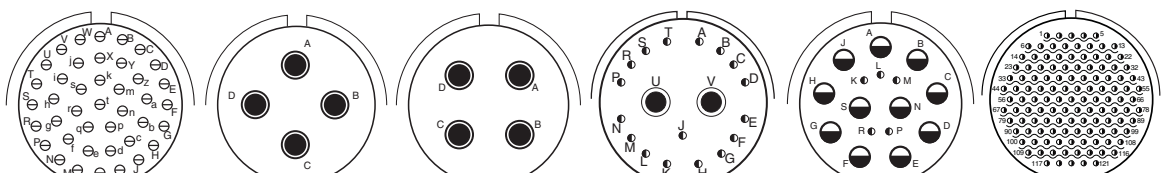

Shell Size & Insert Arrg. for:

Series III TV	21-41	21-48	21-75	21-79	21-99		21-121 HD
Service Rating	I	M	N	II	M		N
Number of Contacts	41	4	4	17 (See Note)	5	11	121
Contact Size	20	8 power	(See Note)	22D	22D	12	23



HD: High Density HD38999
(use size 23 contacts only)

PCB

HD

Power

Bulk

Integral

Plug

Hermetic

Speed

Filter

Access

Tech

MIL-DTL-38999, Series III TV, HD

Insert Arrangements

Front face of pin inserts illustrated

- PCB
- HD
- Power
- Bulk
- Integral
- Plug
- Hermetic
- Speed
- Filter
- Access

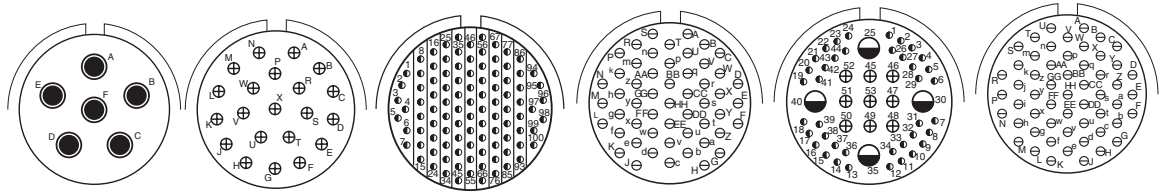

Shell Size & Insert Arrg. for:

Series III TV	23-6	23-21	23-35	23-53	23-54	23-55
Service Rating	M	II	M	I	M	I
Number of Contacts	6	21	100	53	40 9 4	55
Contact Size	8 Twinax	16	22D	20	22D 16 12	20

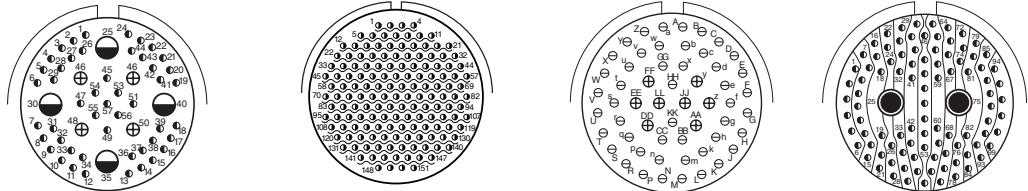

Shell Size & Insert Arrg. for:

Series III TV	23-63			23-151 HD	25-4		25-7	
Service Rating	M			N	I		M	
Number of Contacts	49	4	4	151	48	8	97	2
Contact Size	22D	16 Coax	12 Coax	23	20	16	22D	8 Twinax

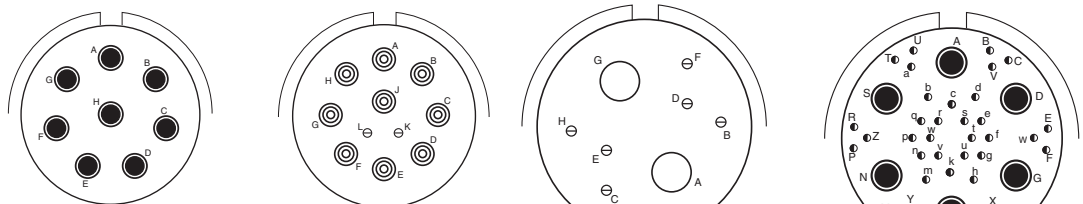

Shell Size & Insert Arrg. for:

Series III TV	25-8 25-10^ 25-88	25-11***		25-16		25-17	
Service Rating	Twinax / Coax		N		M		M
Number of Contacts	8		2	9	6	2	36 6
Contact Size	8 Twinax / 8 Coax (88)		20	10	20	4	22D 8 Twinax

HD: High Density HD38999 (use size 23 contacts only)
Note: MS connector 21-75 is supplied with four size 8 twinax contacts.
 Commercial connector 21-75 is supplied with four size 8 coax contacts.
 MS connector 21-79 has provision for two size 8 coax contacts.
 Coax contacts are not supplied unless specified by customers.

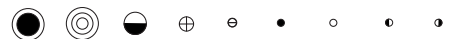

CONTACT LEGEND 8 10 12 16 20 22 22M 22D 23

MIL-DTL-38999, Series III TV

Insert Arrangements

Front face of pin inserts illustrated

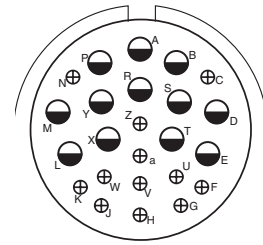
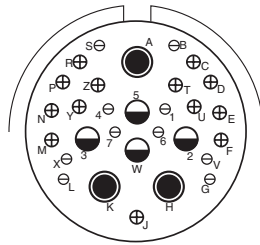
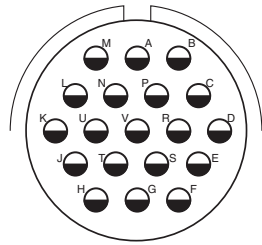

Shell Size &
Insert Arrg. for:

Series III TV	25-19		25-20***				25-24	
Service Rating	I		N				I	
Number of Contacts	19		10	13	3	4	12	12
Contact Size	12		20	16	8 Twinax	12 Coax	16	12
			(With Matched Impedance)					

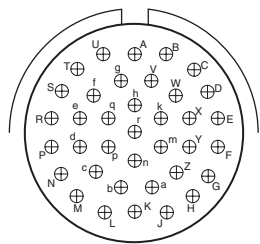
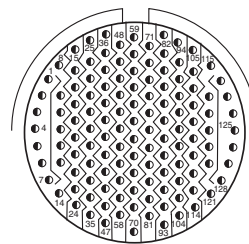
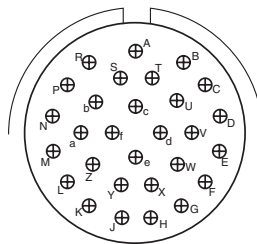
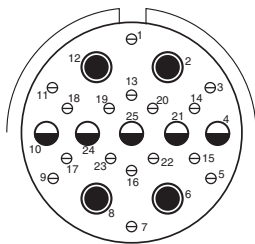

Shell Size &
Insert Arrg. for:

Series III TV	25-26			25-29		25-35		25-37	
Service Rating	I			I		M		I	
Number of Contacts	16	5	4	29		128		37	
Contact Size	20	12	8 Coax	16		22D		16	

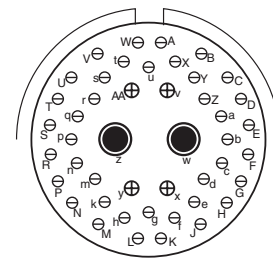
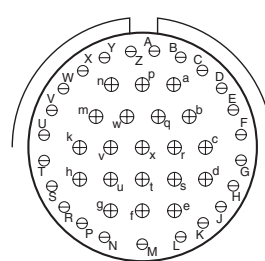
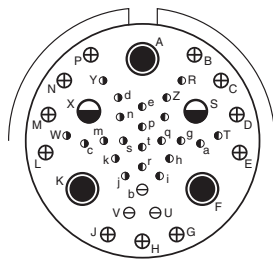

Shell Size &
Insert Arrg. for:

Series III TV	25-41					25-43		25-46		
Service Rating	N/Inst.					I		I		
Number of Contacts	22	3	11	2	3	23	20	40	4	2
Contact Size	22D	20	16	12 Coax	8 Twinax	20	16	20	16	8 Coax †



CONTACT LEGEND 8 10 12 16 20 22 22M 22D 23

PCB
HD
Power
Bulk
Integral
Plug
Hermetic
Speed
Filter
Access
Tech

MIL-DTL-38999, Series III TV, HD

Insert Arrangements

Front face of pin inserts illustrated

- PCB
- HD
- Power
- Bulk
- Integral
- Plug
- Hermetic
- Speed
- Filter
- Access

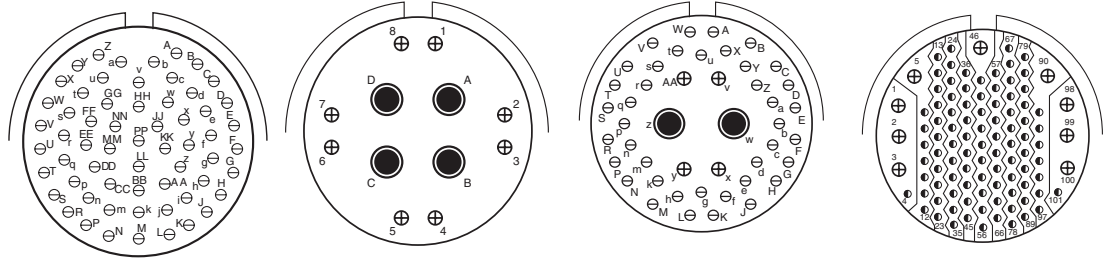

Shell Size & Insert Arrg. for:

Series III TV	25-61	25-62	25-90	25-92
Service Rating	I	I	I	M
Number of Contacts	61	8 4	40 4 2	92 9
Contact Size	20	16 8	20 16 8 Twinax	22D 16
		Ground Plane Only		

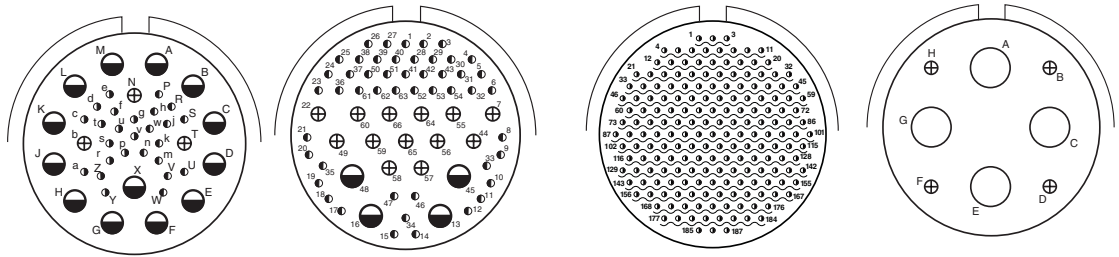

Shell Size & Insert Arrg. for:

Series III TV	25-97	25-F4	25-187 HD	25-1A
Service Rating	M	Size 22D=M, Balance =I	N	N
Number of Contacts	26 3 13	49 13 4	187	4 4
Contact Size	22D 16 12	22D 16 12	23	16 4

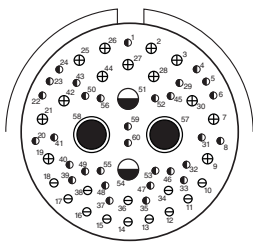

Shell Size & Insert Arrg. for:

Series III TV	25-AT
Service Rating	N
Number of Contacts	2 2 13 12 31
Contact Size	10 12 16 20 22D

NOTE: Some specials shown here were formerly known as Pyle arrangements. Consult Amphenol for how to order information for connectors with these inserts. For further information on special arrangements consult Amphenol Aerospace, Sidney NY. * Pyle 15-4 does not mate with Amphenol Tri-Start 15-4 insert.



† Coax contacts for RG180/U or RG195/U cable.

HD: High Density HD38999 (use size 23 contacts only)

Special Insert Arrangements

Non-Standard Shells or Large Contacts

Front face of pin inserts illustrated

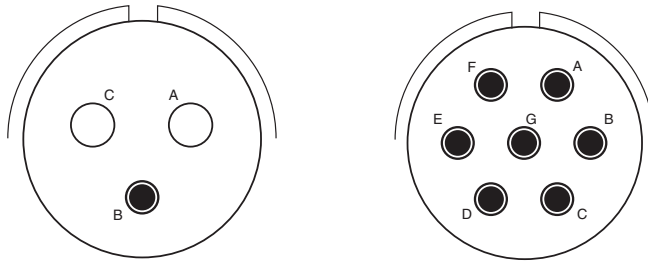

Shell Size &
Insert Arrg. for:

Series III TV	25L-3		25L-7	
Service Rating	II		II	
Number of Contacts	1	2	7	
Contact Size	8	4	8	

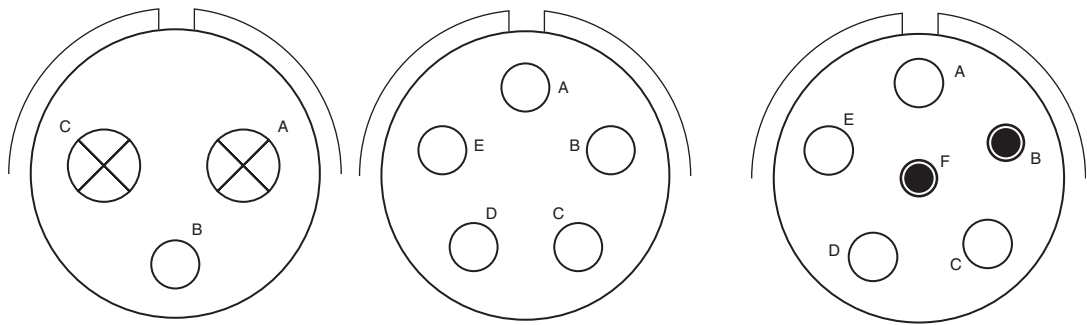

Shell Size &
Insert Arrg. for:

Series III TV	33-3		33-5		33-6	
Service Rating	II		II		II	
Number of Contacts	1	2	5		2	4
Contact Size	4	0	4		8	4

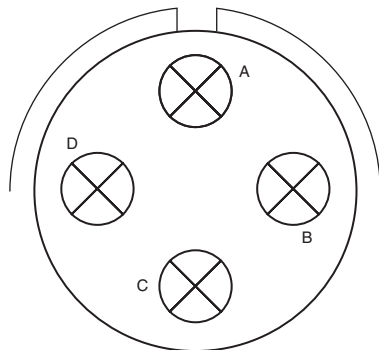

Shell Size &
Insert Arrg. for:

Series III TV	37-5
Service Rating	II
Number of Contacts	4
Contact Size	0

NOTE: Some specials shown here were formerly known as Pyle arrangements. Consult Amphenol for how to order information for connectors with these inserts.
Consult Amphenol Aerospace for longer shell drawings.

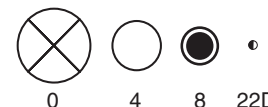

CONTACT LEGEND

PCB
HD
Power
Bulk
Integral
Plug
Hermetic
Speed
Filter
Access
Tech

Alternate Keying Information

6. Select a Alternate Keying

A, B, C, D, E or blank for normal.

Shell Size	Key & Keyway Arrangement Identification Letter	AR° or AP° BSC	BR° or BP° BSC	CR° or CP° BSC	DR° or DP° BSC
7, 7H	N*	120	240	NA	NA
	A	132	248		
	B	80	230		
	C	140	275		
	D	155	234		
9	N*	105	140	215	265
	A	102	132	248	320
	B	80	118	230	312
	C	35	140	205	275
	D	64	155	234	304
11, 13, and 15	N*	95	141	208	236
	A	113	156	182	292
	B	90	145	195	252
	C	53	156	220	255
	D	119	146	176	298
17 and 19	N*	80	142	196	293
	A	135	170	200	310
	B	49	169	200	244
	C	66	140	200	257
	D	62	145	180	280
21, 23, and 25	N*	80	142	196	293
	A	135	170	200	310
	B	49	169	200	244
	C	66	140	200	257
	D	62	145	180	280
25L, 33, and 37	N*	80	142	188	293
	A	135	170	188	310
	B	49	169	188	244
	C	66	140	188	257
	D	62	145	188	280
	N*	80	142	188	293
	A	135	170	188	310
	B	49	169	188	244
	C	66	140	188	257
	D	62	145	188	280
	N*	80	142	188	293
	A	135	170	188	310
	B	49	169	188	244
	C	66	140	188	257
	D	62	145	188	280
	N*	80	142	188	293
	A	135	170	188	310
	B	49	169	188	244
	C	66	140	188	257
	D	62	145	188	280
	N*	80	142	188	293
	A	135	170	188	310
	B	49	169	188	244
	C	66	140	188	257
	D	62	145	188	280
	N*	80	142	188	293
	A	135	170	188	310
	B	49	169	188	244
	C	66	140	188	257
	D	62	145	188	280
	N*	80	142	188	293
	A	135	170	188	310
	B	49	169	188	244
	C	66	140	188	257
	D	62	145	188	280

* An "N" designation is used on D38999 military part number but not on the commercial versions

Key/Keyway Position

A plug with a given rotation letter will mate with a receptacle with the same rotation letter. The angles for a given connector are the same whether it contains pins or sockets. Master key stays fixed, minor keys rotate. Inserts are not rotated in conjunction with the master key/keyway.

RECEPTACLE (front face shown)

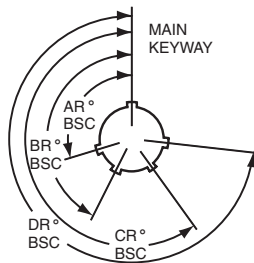

PLUG (front face shown)

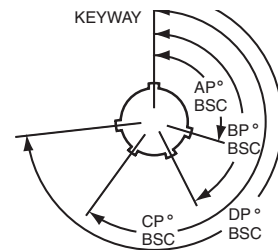

A plug with a given rotation letter will mate with a receptacle with the same rotation letter. The angles for a given connector are the same whether it contains pins or sockets. Inserts are not rotated in conjunction with the master key/keyway.

Contact Ratings/ Service Ratings

CONTACT RATING FOR TV III, HD

Contact Size	Test Current (Amps)		Maximum Millivolt Drop Crimp*	Maximum Millivolt Drop Hermetic*
	Crimp	Hermetic		
23	5	3	73	85
22M	3	2	45	60
22D	5	3	73	85
22	5	3	73	85
20	7.5	5	55	60
16	13	10	49	85
12	23	17	42	85
10 (Power)	33	NA	33	NA
8 (Power)	46	NA	26	NA
4	80	NA	23	NA
0	150	NA	21	NA

*When tested using silver plated wire.

Contact Size	Crimp Well Data		Solder Well Data	
	Well Diameter	Normal Well Depth	Well Diameter	Nominal Well Depth
23	.0345 ± .0010	.141	.0345 ± .0010	.130
22M	.028 ± .001	.141	.029 +.004 - .000	
22D	.0345 ± .0010	.141	.036 +.004 - .000	.094
22	.0365 ± .0010	.141	.036 +.004 - .000	.094
20	.047 ± .001	.209	.044 +.004 - .004	.125
16	.067 ± .001	.209	.078 +.000 - .004	.141
12	.100 ± .002	.209	.116 +.004 - .002	.141
10 (Power)	.137 ± .002	.355	NA	NA
8	.181 ± .002	.490	NA	NA
4	.281 ± .002	.490	NA	NA
0	.453 ± .002	.585	NA	NA

MIL-DTL-38999 SERIES III STANDARD 500 CYCLE CONTACTS FOR TV AND CTV, P & S

Contact Size	TV/CTV Pins		TV/CTV Sockets	
	Military No.	Supersedes	Military No.	Supersedes
8 (Coax)*	M39029/60-367	MS27536	M39029/59-366	MS27535
8 (Power)	Contact Factory	"	"	"
8 (Twinax)	M39029/90-529**	N/A	M39029/91-530	N/A
10 (Power)	M39029/58-528	N/A	M39029/56-527	N/A
12	M39029/58-365	MS27493-12	M39029/56-353	MS27490-12
16	M39029/58-364	MS27493-16	M39029/56-352	MS27490-16
20	M39029/58-363	MS27493-20	M39029/56-351	MS27490-20
22D	M39029/58-360	MS27493-22D	M39029/56-348	MS27490-22D
4	N/A	N/A	N/A	N/A
0	N/A	N/A	N/A	N/A

Above part numbers include standard 500 cycle finish designation - gold plating over suitable underplate in accordance with SAE AS39029. For other finish variations, consult Amphenol Aerospace.

*For use with RG180B/U and RG195A/U cable. For other size 8 coax or optional sizes 12 and 16 coax contacts available for use in Tri-Start connectors, see High Speed catalog or consult Amphenol Aerospace.

MIL-DTL-38999 SERIES III 1500 CYCLE CONTACTS, CLASSES H & J

Contact Size	CTV Pins			CTV Sockets		
	Commercial No.	Military No.	Supersedes	Commercial No.	Military No.	Supersedes
12	10-597072-2X	M39029/107-623	-	10-597073-2X	M39029/106-617	-
16	10-597068-2X	M39029/107-622	-	10-597069-2X	M39029/106-616	-
20	10-597064-2X	M39029/107-621	-	10-597065-2X	M39029/106-615	-
22D	10-597058-3X	M39029/107-620	-	10-597061-2X	M39029/106-614	-



MIL-DTL-38999, Series III TV

Service Rating/Sealing Plugs

- PCB
- HD
- Power
- Bulk
- Integral
- Plug
- Hermetic
- Speed
- Filter
- Access
- Tech

SERVICE RATING**

Service Rating	Suggested Oper. Voltage (Sea Level)		Test Voltage (Sea Level)	Test Voltage 50,000 Ft.	Test Voltage 70,000 Ft	Test Voltage 110,000 Ft.
	AC (RMS)	DC				
M	400	500	1300 VRMS	550 VRMS	350 VRMS	200 VRMS
N	300	450	1000 VRMS	400 VRMS	260 VRMS	200 VRMS
I	600	850	1800 VRMS	600 VRMS	400 VRMS	200 VRMS
II	900	1250	2300 VRMS	800 VRMS	500 VRMS	200 VRMS

** Please note that the establishment of electrical safety factors is left entirely in the designer's hands, since they are in the best position to know what peak voltage, switching surges, transients, etc. can be expected in a particular circuit.

MIL-DTL-38999 SERIES III SEALING PLUGS

Contact Size	Commercial No.	Military No.
8 (Coax)	10-482099-8	N/A
8 (Twinax)	T3-4008-59P	N/A
8 (Power)	10-405996-83	MS27488-8-3
10 (Power)	T3-4010-59P	M85049/81-10
12	10-405996-122	MS27488-12-2
16	10-405996-162	MS27488-16-2
20	10-405996-202	MS27488-20-2
22D	10-405996-222	MS27488-22-2
4	10-405996-43	MS27488-4-3
0	10-405996-03	MS27488-0-3

Standard Amphenol Contact AWG Ranges		
Contact Size	Max	Min
23-22	22	28
22D	22	28
22M	24	28
22	22	26
20	20	24
16	16	20
12 (Power)	12	14
10 (Power)	10	12*
8 (Power)	8	10*
4 (Power)	4	6*
0 (Power)	0	2*

*with crimp reducing adapter/bushing AS39029/112

** For use with M17/M176-00002 cable.

† Optional design - see slash sheet MS39029.

For other contact options available for use in Tri-Start connectors (wire wrap, thermocouple, fiber optic), consult Amphenol.