

# RCS Series

Current Sensing Shunts  
77 Amp - 173 Amp



- 3W Power
- 77 Amp to 173 Amp
- 0.1 - 0.5 mOhm Resistance Values
- Simple 4-port Kelvin Structure
- Lead Free Construction
- Non-inductive Metal Element
- Common Applications: Switchgear, Welding, Power Supply



SPECIFICATIONS				
Type	Resistance (mOhm)	Current (A)*	Max Current (A)*	Dimension E (mm)
RCS1	0.1	173	865	7
RCS2	0.2	122	610	9.6
RCS3	0.3	100	500	12
RCS4	0.4	86	430	14.5
RCS5	0.5	77	385	17.5

\*Note: Current & Max current based on bus-bar mounting

All dimensions are nominal (mm)

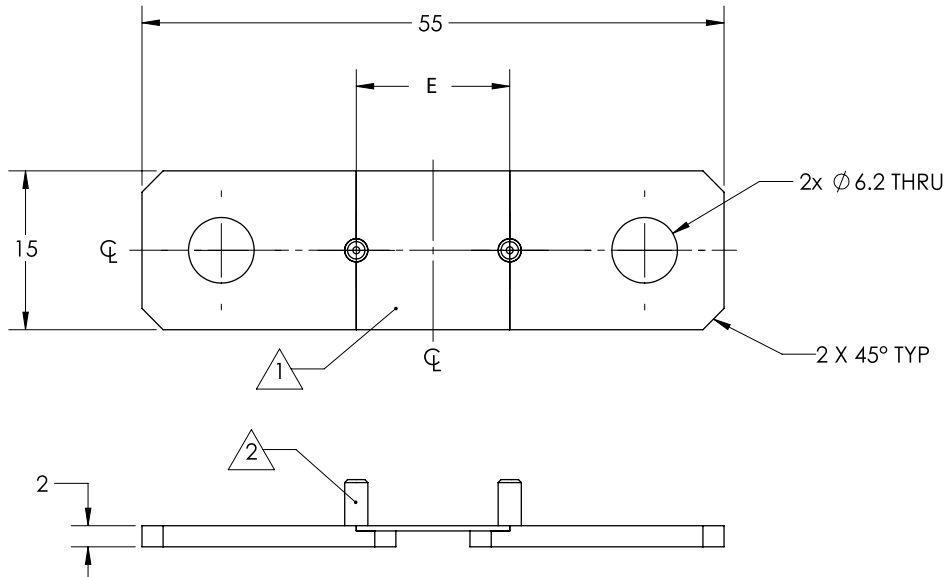

1 — Black epoxy paint over resistance element

2 — #2-56 threaded stainless steel studs 4.2mm protrusion, or 0.8mm thru hole for no stud option

## Ordering Information

Part Description: Part Type - OHM - Tolerance - NS (without studs option)

Example: **RCS1 0.0001 OHM 5%**

# RCS Series

Current Sensing Shunts  
77 Amp - 173 Amp



SPECIFICATIONS	
Resistance Values	0.1 to 0.5 mOhm
Tolerance	±1% or ±5%
TCR	+0 to +100 ppm, please see below
Power	3W
Max Power (Pulse Capability)	100W / 0.1s
Storage Temperature	-55 to +125 C
Operating Temperature	-55 to +175 C
Materials	Flame proof metal construction Contact: Nickel plated Copper Element: Black epoxy paint over Manganin

## Power Derating

% Rated Power

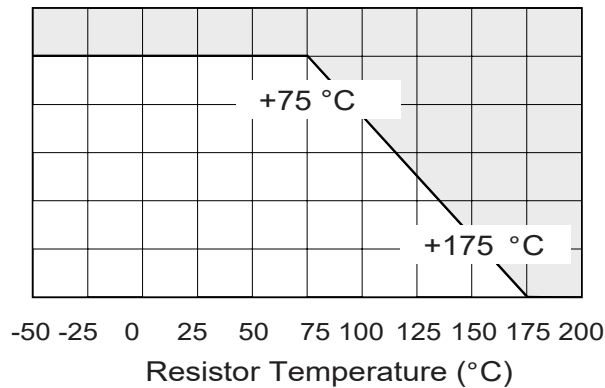

Manganin Temperature Coefficient of Resistance ±15 PPM/C

