



ispMACH™ 5000VG Family

3.3V In-System Programmable
SuperBIG™, SuperWIDE™ High Density PLDs

December 2001

Data Sheet

Features

■ High Density

- 768 to 1,024 macrocells
- 196 to 384 I/Os

■ sysCLOCK™ PLL – Timing Control

- Multiply and divide factors between 1 and 32
- Clock shifting capability ± 3.5 ns in 500ps steps
- Multiple output frequencies
- External feedback capability for board-level clock deskew
- LVDS/LVPECL clock input capability

■ High Speed Logic Implementation

- SuperWIDE 68-input logic block
- Up to 160 product terms per output
- Hierarchical routing structure provides fast interconnect

■ sysIO™ Capability

- LVC MOS 1.8, 2.5 and 3.3
- LVTTTL
- SSTL 2 (I & II)
- SSTL 3 (I & II)
- CTT 3.3, CTT 2.5
- HSTL (I & III)
- PCI-X, PCI 3.3
- GTL+
- AGP-1X
- 5V tolerance
- Programmable drive strength

■ Ease of Design

- Product term sharing
- Extensive clocking and OE capability

■ Easy System Integration

- 3.3V power supply
- Hot socketing
- Input pull-up, pull-down or bus-keeper
- Open drain capability
- Slew rate control
- Macrocell-based power management
- IEEE 1149.1 boundary scan testable
- In-system programmable via IEEE 1532 ISC compliant interface

ispMACH 5000VG Introduction

The ispMACH 5000VG represents the third generation of Lattice's SuperWIDE CPLD architecture. Through their wide 68-input blocks, these devices give significantly improved speed performance for typical designs over architectures with fewer inputs.

The ispMACH 5000VG takes the unique benefits of the SuperWIDE architecture and extends it to higher densities referred to as SuperBIG, by using the combination of an innovative product term architecture and a two-tiered hierarchical routing architecture. Additionally, sysCLOCK and sysIO capabilities have been added to maximize system-level performance and integration.

Table 1. ispMACH 5000VG Family Selection Guide

| | ispMACH 5768VG | ispMACH 51024VG |
|--|----------------------------------|----------------------------------|
| Macrocells | 768 | 1,024 |
| User I/O Options | 196/304 | 304/384 |
| t _{PD} (ns) | 5.0 | 5.0 |
| t _S – Set-up with 0 Hold (ns) | 3.0 | 3.0 |
| t _{CO} (ns) | 4.4 | 4.4 |
| f _{MAX} (MHz) | 178 | 178 |
| Supply Voltage (V) | 3.3V | 3.3V |
| Package | 256-ball fpBGA 484-ball fpBGA | 484-ball fpBGA 676-ball fpBGA |

Figure 1. Functional Block Diagram

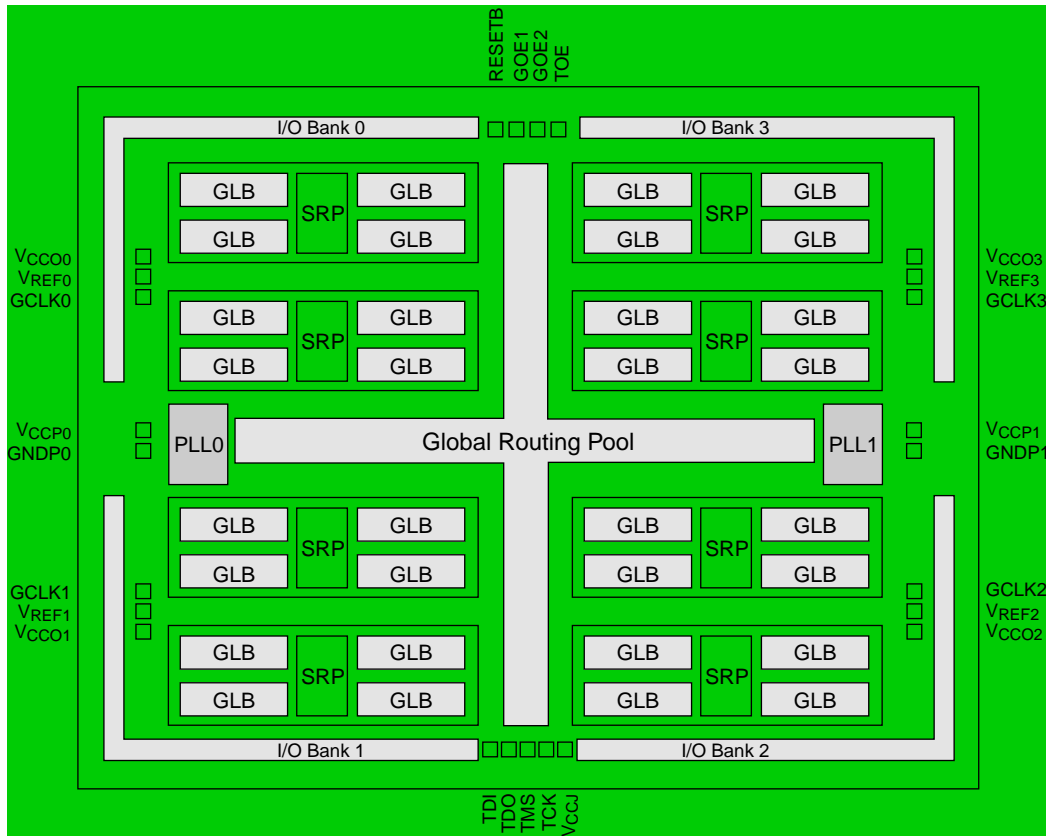

Overview

The ispMACH 5000VG devices consist of multiple SuperWIDE 68-input, 32-macrocell Generic Logic Blocks (GLBs) interconnected by a tiered routing system. Figure 1 shows the functional block diagram of the ispMACH 5000VG. Groups of four GLBs, referred to as segments, are interconnected via a Segment Routing Pool (SRP). Segments are interconnected via the Global Routing Pool (GRP.) Together the GLBs and the routing pools allow designers to create large designs in a single device without compromising performance.

Each GLB has 68 inputs coming from the SRP and contains 163 product terms. These product terms form groups of five product term clusters, which feed the PT sharing array or the macrocell directly. The ispMACH 5000VG allows up to 160 product terms to be connected to a single macrocell via the product term expanders and PT Sharing Array.

The macrocell is designed to provide flexible clocking and control functionality with the capability to select between global, product term and block-level resources. The outputs of the macrocells are fed back into the switch matrices and, if required, the sysIO cell.

All I/Os in the ispMACH 5000VG family are sysIOs, which are split into four banks. Each bank has a separate I/O power supply and reference voltage. The sysIO cells allow operation with a wide range of today’s emerging interface standards. Within a bank, inputs can be set to a variety of standards, providing the reference voltage requirements of the chosen standards are compatible. Within a bank, the outputs can be set to differing standards, providing the I/O power supply voltage and the reference voltage requirements of the chosen standard are compatible. Support for this wide range of standards allows designers to achieve significantly higher board-level performance compared to the more traditional LVCMOS standards.

The ispMACH5000VG devices also contain sysCLOCK Phase Locked Loops (PLLs) that provide designers with increased clocking flexibility. The PLLs can be used to synthesize new clocks for use on-chip or elsewhere within the system. They can also be used to deskew clocks, again both at the chip and system levels. A variable delay line capability further improves this and allows designers to retard or advance the clock in order to tune set-up and clock-to-out times for optimal results. The ispMACH 5000VG Family Selection Guide (Table 1) details the key attributes and packages for the ispMACH 5000VG devices.

ispMACH 5000VG Architecture

The ispMACH 5000VG Family of In-System Programmable High Density Logic Devices is based on segments containing four Generic Logic Blocks (GLBs) and a hierarchical routing pool (GRP) structure interconnecting the segments. A segment routing pool (SRP) connects each GLB in a segment allowing the maximum flexibility and speed.

Outputs from the GLBs drive the Segment Routing Pool (SRP) and the Global Routing Pool (GRP). Enhanced switching resources are provided to allow signals in the Segment Routing Pool to drive any or all the GLBs in the segment. Optimal switching is provided to allow all signals in the Global Routing Pool to be routed to any or all SRPs. This mechanism allows fast, efficient connections across the entire device.

Segment

Each segment contains four GLBs and a segment routing pool (SRP). Each GLB has 32 internal feedback outputs and 16 external feedback outputs, for a total of 48 outputs from each GLB feeding the SRP. The SRP contains up to 384 signals, 48 from each GLB and 192 from the GRP, with full routing capability. This routing scheme maximizes the flexibility and speed of the device without sacrificing the routing.

Figure 2. Segment

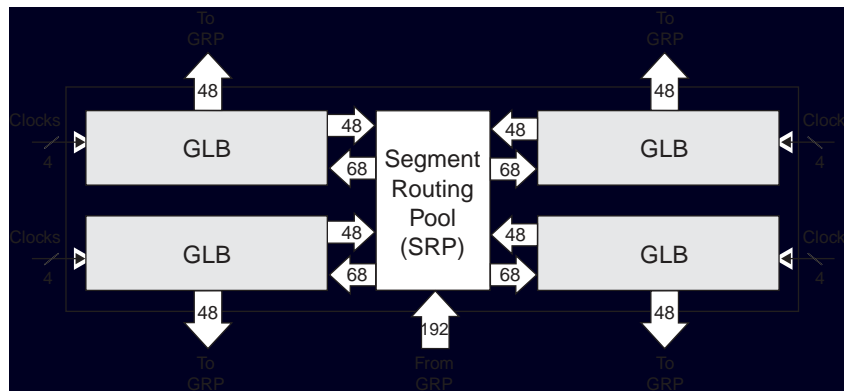

Generic Logic Block

Each GLB contains 32 macrocells and a fully populated, programmable AND-array with 160 logic product terms and three control product terms. The GLB has 68 inputs from the Segment Routing Pool, which are available in both true and complement form for every product term. The three control product terms are used for shared reset, clock and output enable functions. Figure 3 shows the structure of the GLB from the macrocell perspective. This is referred to as a macrocell slice. There are 32 macrocell slices per GLB.

AND-Array

The programmable AND-Array consists of 68 inputs and 163 output product terms. The 68 inputs from the SRP are used to form 136 lines in the AND-Array (true and complement of the inputs). Each line in the array can be connected to any of the 163 output product terms via a wired AND. Each of the 160 logic product terms feed the Dual-OR Array with the remaining three control product terms feeding the Shared PT Clock, Shared PT Reset and Shared PT OE. Every set of five product terms from the 160 logic product terms forms a product term cluster start-

Figure 3. Macrocell Slice

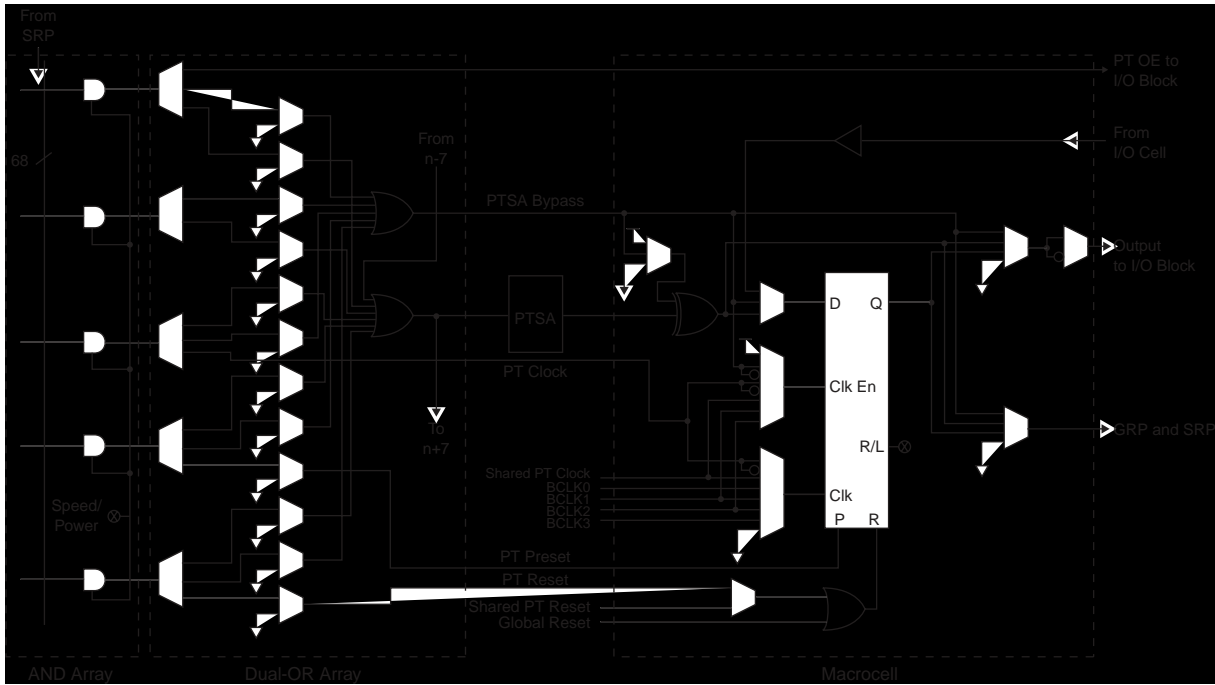
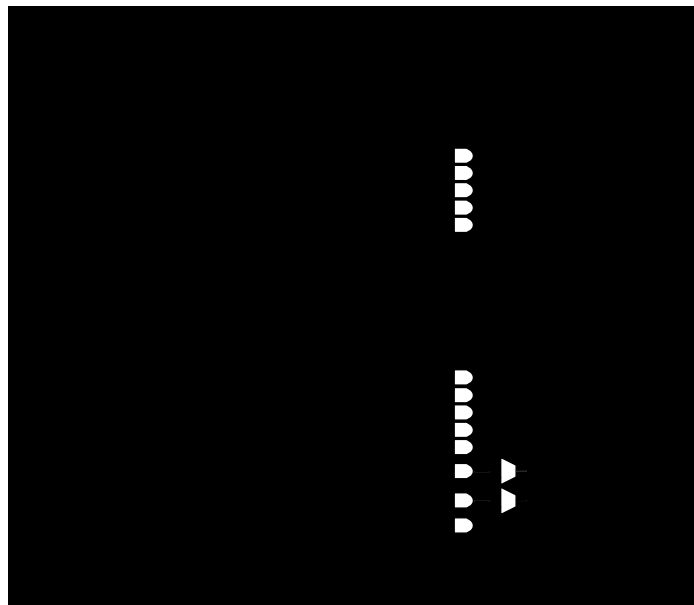

Figure 4. AND-Array



ing with PT0. There is one product term cluster for every macrocell in the GLB. In addition to the three control product terms, the first, third, fourth and fifth product terms of each cluster can be used as a PTOE (output macrocells only), PT Clock, PT Preset and PT Reset, respectively. Figure 4 is a graphical representation of the AND-Array.

Enhanced Dual-OR Array

To facilitate logic functions requiring a very large number of product terms, the ispMACH 5000VG architecture has been enhanced with an innovative product term expander capability. This capability is embedded in the Dual-OR Array. The Dual-OR Array consists of 64 OR gates. There are two OR gates per macrocell in the GLB. These OR gates are referred to as the Expandable PTSA OR gate and the PTSA-Bypass OR gate.

The PTSA-Bypass OR gate receives its five inputs from the combination of product terms associated with the product term cluster. The PTSA-Bypass OR gate feeds the macrocell directly for fast narrow logic. The Expandable PTSA OR gate receives five inputs from the combination of product terms associated with the product term cluster. It also receives an additional input from the Expanded PTSA OR gate of the N-7 macrocell, where N is the number of the macrocell associated with the current OR gate. The Expandable PTSA OR gate feeds the PTSA for sharing with other product terms and the N+7 Expandable PTSA OR gate. This allows cascading of multiple OR gates for wide functions. There is a small timing adder for each level of expansion. Figure 5 is a graphical representation of the Enhanced Dual-OR Array.

Figure 5. Enhanced Dual-OR Array

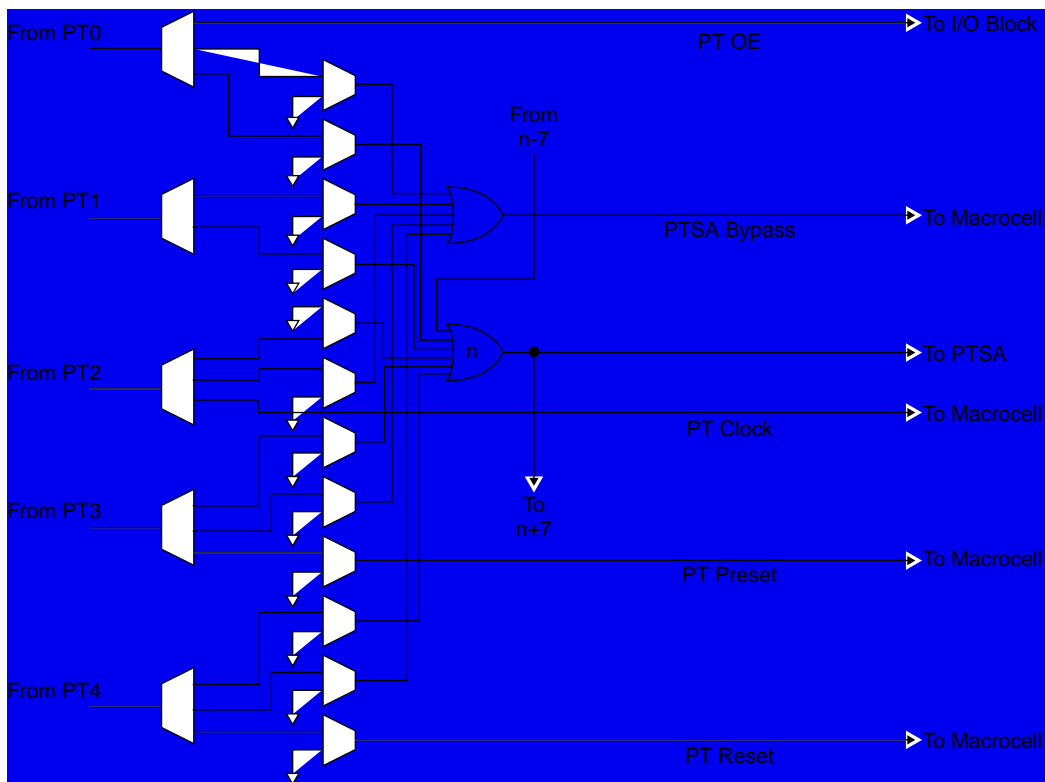

Product Term Sharing Array

The Product Term Sharing Array (PTSA) consists of 32 inputs from the Dual-OR Array (Expandable PTSA OR) and 32 outputs directly to the macrocells. Each output is the OR term of any combination of the seven Expandable PTSA OR terms connected to that output. Every Nth macrocell is connected to N-3, N-2, N-1, N, N+1, N+2 and N+3 PTSA OR terms via a programmable connection. This wraps around the logic, Macrocell 0 gets its logic from 29, 30, 31, 0, 1, 2, 3. The Expandable PTSA OR used in conjunction with the PTSA allows wide functions to be implemented easily and efficiently. Without using the Expandable PTSA OR capability, the greatest number of product terms that can be included in a single function with one pass of delay is 35. Figure 6 shows the graphical representation of the PTSA.

Figure 6. Product Term Sharing Array

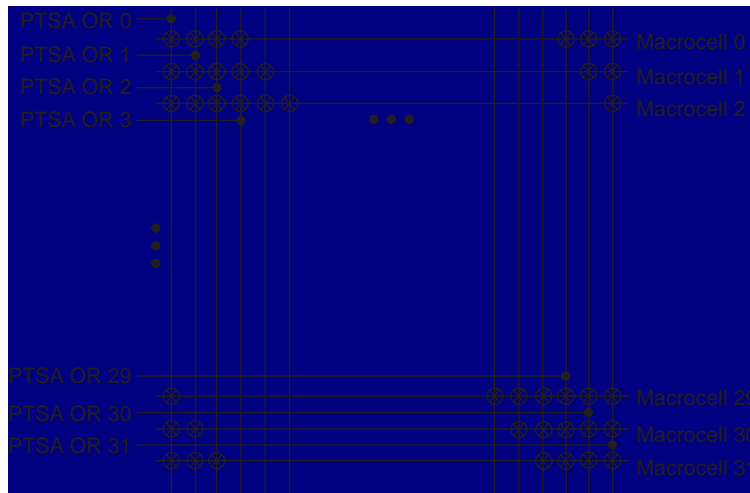

Macrocell

The 32 registered macrocells in the GLB are driven by the 32 outputs from the PTSA or the PTSA bypass. Each macrocell contains a programmable XOR gate, a programmable register/latch flip-flop and the necessary clocks and control logic to allow combinatorial or registered operation.

The macrocells each have two outputs, which can be fed to the SRP, GRP and I/O cell. This dual or concurrent output capability from the macrocell gives efficient use of the hardware resources. One output can be a registered function for example, while the other output can be an unrelated combinatorial function. A direct register input from the I/O cell facilitates efficient use of the macrocell to construct high-speed input registers.

Macrocell registers can be clocked from one of several global or product term clocks available on the device. A global and product term clock enable is also provided, eliminating the need to gate the clock to the macrocell registers directly. Reset and preset for the macrocell register is provided from both global and product term signals. The macrocell register can be programmed to operate as a D-type register or a D-type latch. Figure 7 is a graphical representation of the ispMACH 5000VG macrocell.

Figure 7. Macrocell

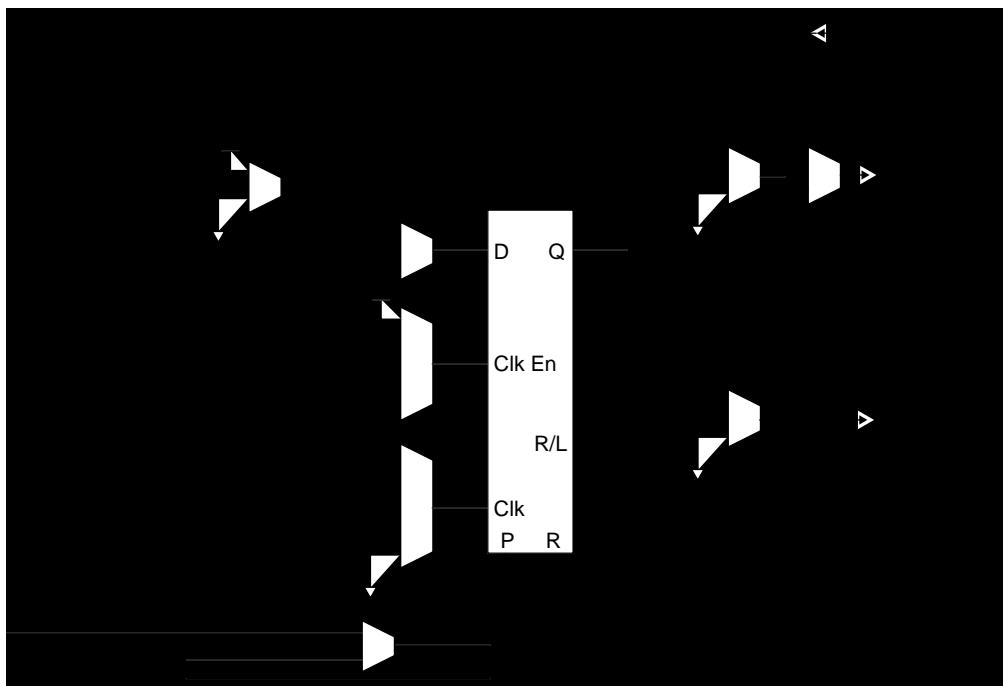

I/O Cell

The I/O cell of the ispMACH 5000VG device provides a high degree of flexibility. It includes the sysIO feature and an enhanced output enable MUX for optimal performance both on- and off-chip. The sysIO feature allows I/O cells to be configured to different I/O standards, drive strengths and slew rates. The enhanced output enable MUX provides up to 14 different output enable choices per I/O cell.

The I/O cell contains an output enable (OE) MUX, a programmable tri-state output buffer, a programmable input buffer, a programmable pull-up resistor, a programmable pull-down resistor and a programmable bus-keeper latch. The I/O cell receives its input from its associated macrocell. The I/O cell has a feedback line to its associated macrocell and a direct path to the GRP and SRP.

The output enable (OE) MUX selects the OE signal per I/O cell. The inputs to the OE MUX are the four Shared PTOE signals, PTOE and the two GOE signals. The OE MUX also has the ability to choose either the true or inverse of each of these signals. The output of the OE MUX goes through a logical AND with the TOE signal to allow easy tri-stating of the outputs for testing purposes.

The four shared PTOE signals are derived from PT163 of each GLB in the segment. The PTOE signal is derived from the first product term in each macrocell cluster, which is directly routed to the OE MUX. Therefore, every I/O cell can have a different OE signal. Figure 8 is a graphical representation of the I/O cell.

Figure 8. I/O Cell

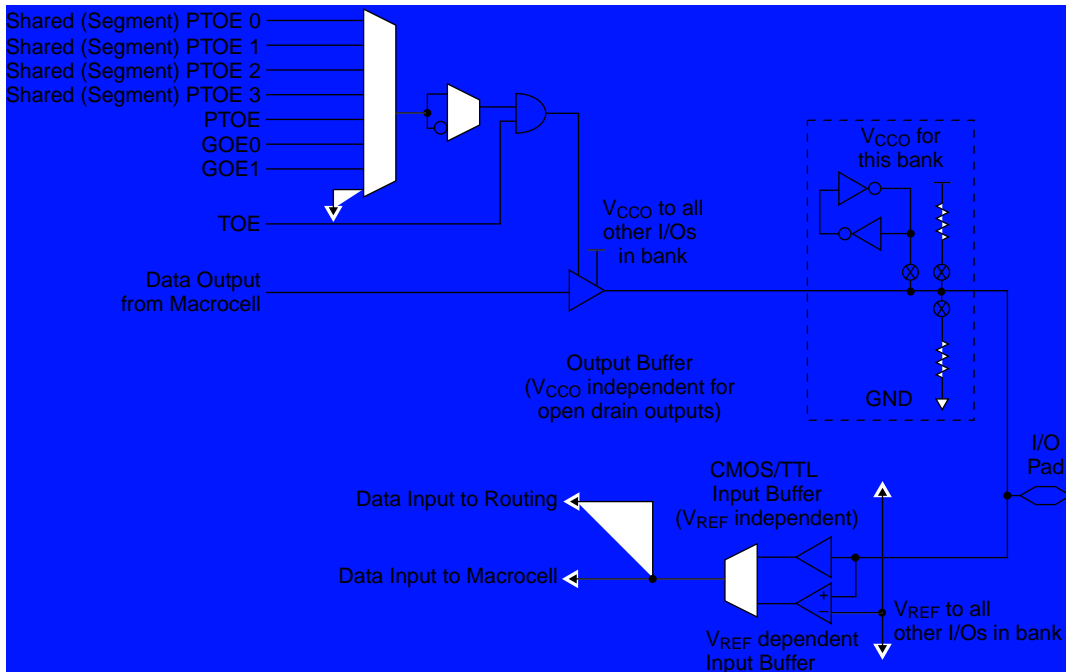

sysIO Capability

The ispMACH 5000VG devices are divided into four sysIO banks, where each bank is capable of supporting 14 different I/O standards. Each sysIO bank has its own I/O supply voltage (V_{CCO}) and reference voltage (V_{REF}) resources allowing each bank complete independence from the others. Each I/O within a bank is individually configurable based on the V_{CCO} and V_{REF} settings. Table 2 lists the sysIO standards with the typical values for V_{CCO}, V_{REF} and V_{TT}.

Table 2. ispMACH 5000VG Supported I/O Standards

| sysIO Standard | V _{CCO} | V _{REF} | V _{TT} |
|-----------------------------------|------------------|------------------|-----------------|
| LVTTTL | 3.3V | N/A | N/A |
| LVC MOS-3.3 | 3.3V | N/A | N/A |
| LVC MOS-2.5 | 2.5V | N/A | N/A |
| LVC MOS-1.8 | 1.8V | N/A | N/A |
| PCI 3.3 | 3.3V | N/A | N/A |
| PCI-X | 3.3V | N/A | N/A |
| AGP-1X | 3.3V | N/A | N/A |
| SSTL3, Class I & II | 3.3V | 1.5V | 1.5V |
| SSTL2, Class I & II | 2.5V | 1.25V | 1.25V |
| CTT 3.3 | 3.3V | 1.5V | 1.5V |
| CTT 2.5 | 2.5V | 1.25V | 1.25V |
| HSTL, Class I | 1.5V | 0.75V | 0.75V |
| HSTL, Class III | 1.5V | 0.9V | 1.5V |
| GTL+ | N/A | 1.0V | 1.5V |
| LVPECL, Differential ¹ | N/A | N/A | N/A |
| LVDS ¹ | N/A | N/A | N/A |

1. LVDS and LVPECL are only supported on the dedicated clock pins.

Global clock pins have additional capabilities that allow for higher performance applications. Two global clock pins can be paired together to create a single global clock pin that can interface with certain differential signals.

The TOE and JTAG pins of the ispMACH 5000VG device are the only pins that do not have sysIO capabilities. These pins only support the LVTTTL and LVCMOS standards.

There are three classes of I/O interface standards that are implemented in the ispMACH 5000VG devices. The first is the unterminated, single-ended interface. It includes the 3.3V LVTTTL standard along with the 1.8V, 2.5V and 3.3V LVCMOS interface standards. Additionally, PCI 3.3, PCI-X and AGP-1X are all subsets of this type of interface.

The second type of interface implemented is the terminated, single-ended interface standard. This group of interfaces includes different versions of SSTL and HSTL interfaces along with CTT and GTL+. Usage of these particular I/O interfaces requires the use of an additional VREF signal. At the system level, a termination voltage, VTT, is also required. Typically, an output will be terminated to VTT at the receiving end of the transmission line it is driving.

The final types of interfaces implemented are the differential standards LVDS and LVPECL. These interfaces are implemented on clock pins only. When using one of the differential standards, a pair of global clock pins (GCLK0 and GCLK1 or GCLK3 and GCLK2) is combined to create a single clock signal.

For more information on the sysIO capability, please refer to Technical Note TN1000: *ispMACH 5000VG sysIO Design and Usage Guidelines*.

GLB Clock Distribution

The ispMACH 5000VG family has four dedicated clock input pins: GCLK0-GCLK3. GCLK0 and GCLK3 can be routed through a PLL circuit or routed directly to the internal clock nets. The internal clock nets (CLK0-CLK3) are directly related to the dedicated clock pins (see Secondary Clock Divider exception when using the sysCLOCK circuit). These feed the GLB clock multiplexes which generate the GLB clock signals (BCLK0-BCLK3). The GLB clock multiplexer allows a variety of true and complementary versions of the clocks to be used within the GLB. Each block clock can be the true or inverse of its associated global clock or the inverse of the adjacent global clock. Figure 9 shows the clock distribution network.

Figure 9. Clock Distribution Network

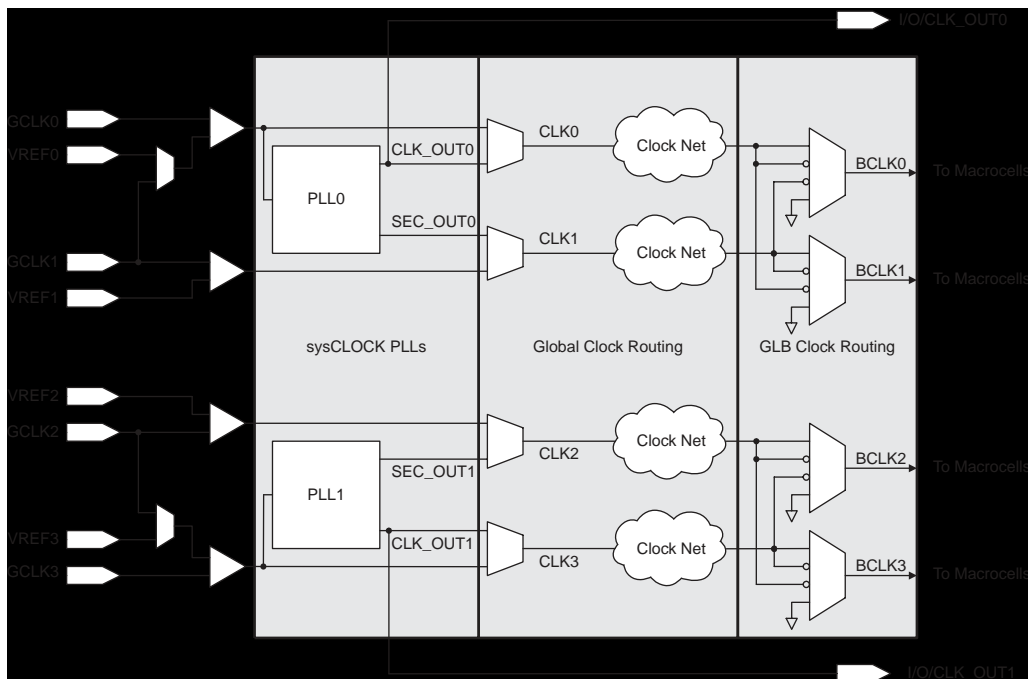

sysCLOCK PLL

The sysCLOCK PLL circuitry consists of Phase-Lock Loops (PLLs) and the various dividers, reset and feedback signals associated with the PLLs. This feature gives the user the ability to synthesize clock frequencies and generate multiple clock signals for routing within the device. Furthermore, it can generate clock signals that are deskewed either at the board level or the device level.

The ispMACH 5000VG devices provide two PLL circuits. PLL0 receives its clock inputs from GCLK 0 and provides outputs to CLK 0 (CLK 1 when using the secondary clock). PLL1 operates with signals from GCLK 3 and CLK 3 (CLK 2 when using the secondary clock). The PLL outputs (CLK_OUT) are routed via a dedicated net to a dedicated pad. Further the buffers at these dedicated pads are regular I/O buffers that can select either the I/O macro-cell or the CLK_OUT (CLK_OUT0/CLK_OUT1) signal. The CLK_OUT nets are not routed through the GRP. Additionally, there are two sets of signals used for external control. Each PLL has a set of PLL_RST, PLL_FBK and PLL_LOCK signals. Figure 10 shows the ispMACH 5000VG PLL block diagram.

Figure 10. PLL Block Diagram

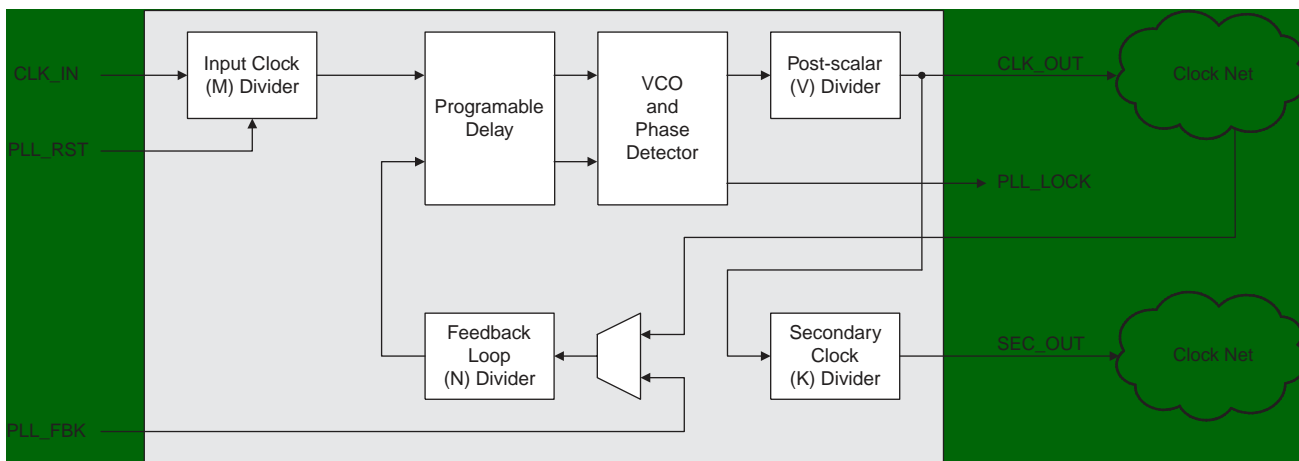

In order to facilitate the multiply and divide capabilities of the PLL, each PLL has dividers associated with it: M, N and K. The M divider is used to divide the clock signal, while the N divider is used to multiply the clock signal. The K divider is only used when a secondary clock output is needed. This divider divides the primary clock output and feeds to a separate global clock net. The V divider is used to provide lower frequency output clocks, while maintaining a stable, high frequency output from the PLL's VCO circuit.

The PLL also has a delay feature that allows the output clock to be advanced or delayed to improve set-up and clock-to-out times for better performance. This operates by inserting delay on the input or feedback lines in 0.5ns increments from 0 to 3.5ns. For more information on the PLL, please refer to Technical Note TN1003: *ispMACH 5000VG PLL Usage Guidelines*.

Power Management

The ispMACH 5000VG devices provide unique power management controls. The devices have two power settings, high power and low power, on a per node basis. Low power consumption is approximately 50% of high power consumption with a timing delay adder (tLP) to the routing delay of the low power node. Each node can be configured as either high power or low power. However, care should be taken when sharing product terms between nodes with different power settings.

The ispMACH 5000VG devices also have a power-off feature for unused product terms. By default, any product term that is not used is configured as such. This allows the device to operate at minimal power consumption without affecting the timing of the design. For more information on power management, please refer to Technical Note TN1002: *Power Estimation in ispMACH 5000VG Devices*.

IEEE 1149.1-Compliant Boundary Scan Testability

All ispMACH 5000VG devices have boundary scan cells and are compliant to the IEEE 1149.1 standard. This allows functional testing of the circuit board on which the device is mounted through a serial scan path that can access all critical logic nodes. Internal registers are linked internally, allowing test data to be shifted in and loaded directly onto test nodes, or test node data to be captured and shifted out for verification. In addition, these devices can be linked into a board-level serial scan path for more board-level testing. The test access port has its own supply voltage and can operate with LVCMOS3.3, 2.5 and 1.8V standards.

sysIO Quick Configuration

To facilitate the most efficient board test, the physical nature of the I/O cells must be set before running any continuity tests. As these tests are fast, by nature, the overhead and time that is required for configuration of the I/Os' physical nature should be minimal so that board test time is minimized. The ispMACH 5000VG family of devices allows this by offering the user the ability to quickly configure the physical nature of the sysIO cells. This quick configuration takes milliseconds to complete, whereas it takes seconds for the entire device to be programmed. Lattice's ispVM™ System programming software can either perform the quick configuration through the PC parallel port, or can generate the ATE or test vectors necessary for a third-party test system.

IEEE 1532-Compliant In-System Programming

In-system programming of devices provides a number of significant benefits including rapid prototyping, lower inventory levels, higher quality and the ability to make in-field modifications. All ispMACH 5000VG devices provide In-System Programming (ISP™) capability through their Boundary Scan Test Access Port. This capability has been implemented in a manner that ensures that the port remains compliant to the IEEE 1532 standard. By using IEEE 1532 as the communication interface through which ISP is achieved, customers get the benefit of a standard, well-defined interface.

The ispMACH 5000VG devices can be programmed across the commercial temperature and voltage range. The PC-based Lattice software facilitates in-system programming of ispMACH 5000VG devices. The software takes the JEDEC file output produced by the design implementation software, along with information about the scan chain, and creates a set of vectors used to drive the scan chain. The software can use these vectors to drive a scan chain via the parallel port of a PC. Alternatively, the software can output files in formats understood by common automated test equipment. This equipment can then be used to program ispMACH 5000VG devices during the testing of a circuit board.

Security Bit

A programmable security bit is provided on the ispMACH 5000VG devices as a deterrent to unauthorized copying of the array configuration patterns. Once programmed, this bit prevents readback of the programmed pattern by a device programmer, securing proprietary design from competitors. The security bit also prevents programming and verification. The entire device must be erased in order to erase the security bit.

Hot Socketing

The ispMACH 5000VG devices are well suited for those applications that require hot socketing capability. Hot socketing a device requires that the device, when powered down, can tolerate active signals on the I/Os and inputs without being damaged. Additionally, it requires that the effects of the powered-down device be minimal on active signals.

Density Migration

The ispMACH 5000 family has been designed to ensure that different density devices in the same package have the same pin-out. Furthermore, the architecture ensures a high success rate when performing design migration from lower density parts to higher density parts. In many cases, it is possible to shift a lower utilization design targeted for a high density device to a lower density device. However, the exact details of the final resource utilization will impact the likely success in each case.

Absolute Maximum Ratings^{1, 2, 3}

- Supply Voltage (V_{CC}) -0.5 to 5.4V
- PLL Supply Voltage (V_{CCP}) -0.5 to 5.4V
- Output Supply Voltage (V_{CCO}) -0.5 to 5.4V
- Input Voltage Applied⁴ -0.5 to 5.6V
- Tri-state Output Voltage Applied. -0.5 to 5.6V
- Storage Temperature -65 to 150°C
- Junction Temperature (T_j) with Power Applied -55 to 130°C

1. Stress above those listed under the “Absolute Maximum Ratings” may cause permanent damage to the device. Functional operation of the device at these or any other conditions above those indicated in the operational sections of this specification is not implied.
2. Compliance with Lattice *Thermal Management* document is required.
3. All voltages referenced to GND.
4. Overshoot and Undershoot of -2V to (V_{IH} (MAX)+2) volts is permitted for a duration of < 20ns.

Recommended Operating Conditions

| Symbol | Parameter | Min | Max | Units |
|--------------------|--|------|-----|-------|
| V_{CC} | Supply Voltage | 3.0 | 3.6 | V |
| V_{CCP} | Supply Voltage for PLL block | 3.0 | 3.6 | V |
| V_{CCJ} | Supply Voltage for IEEE1149.1 Test Access Port | 1.65 | 3.6 | V |
| T_j (Commercial) | Junction Commercial Operation | 0 | 90 | C |
| T_j (Industrial) | Junction Industrial Operation | -40 | 105 | C |

Note: V_{CCJ} must be set in appropriate range to be compatible with desired LVCMOS standard.

Erase Reprogram Specifications

| Parameter | Min | Max | Units |
|-----------------------|------|-----|--------|
| Erase/Reprogram Cycle | 1000 | — | Cycles |

Hot Socketing Characteristics^{1,2,3}

| Symbol | Parameter | Condition | Min | Typ | Max | Units |
|----------|------------------------------|--|-----|-----|--------|---------|
| I_{DK} | Input or I/O Leakage Current | $0 \leq V_{IN} \leq V_{IH}$ (MAX) | — | — | +/-100 | μ A |
| | | V_{IH} (MAX) $\leq V_{IN} \leq 5.5V$ | — | — | +/-100 | μ A |

1. Insensitive to sequence of V_{CC} and V_{CCO} . However, assumes monotonic rise / fall rates for V_{CC} and V_{CCO} .
2. LVTTTL, LVCMOS only
3. $0 < V_{CC} \leq V_{CC}$ (MAX), $0 < V_{CCO} \leq V_{CCO}$ (MAX)

DC Electrical Characteristics

Over Recommended Operating Conditions

| Symbol | Parameter | Condition | Min | Typ | Max | Units | |
|--------------------|---------------------------------------|--|-----------------|-----|----------------|---------|---------|
| I_{IL}, I_{IH}^1 | Input or I/O Leakage Current | $0V \leq V_{IN} \leq V_{IH} (MAX)$ | — | — | +/-10 | μA | |
| I_{PU}^2 | I/O Weak Pull-up Resistor Current | $0 \leq V_{IN} \leq 0.7 V_{CCO}$ | $V_{CCO} = 3.3$ | -30 | — | -150 | μA |
| | | | $V_{CCO} = 2.5$ | -20 | — | -150 | μA |
| | | | $V_{CCO} = 1.8$ | -10 | — | -150 | μA |
| I_{PD}^2 | I/O Weak Pull-down Resistor Current | $V_{IL} (MAX) \leq V_{IN} \leq V_{IH} (MAX)$ | 30 | — | 150 | μA | |
| I_{BHLS}^2 | Bus Hold Low Sustaining Current | $V_{IN} = V_{IL} (MAX)$ | 30 | — | — | μA | |
| I_{BHHS}^2 | Bus Hold High Sustaining Current | $V_{IN} = 0.7 V_{CCO}$ | $V_{CCO} = 3.3$ | -30 | — | — | μA |
| | | | $V_{CCO} = 2.5$ | -20 | — | — | μA |
| | | | $V_{CCO} = 1.8$ | -10 | — | — | μA |
| I_{BHLO}^2 | Bus Hold Low Overdrive Current | $0V \leq V_{IN} \leq V_{IH} (MAX)$ | — | — | 150 | μA | |
| I_{BHHO}^2 | Bus Hold High Overdrive Current | $0V \leq V_{IN} \leq V_{IH} (MAX)$ | — | — | -150 | μA | |
| $I_{CC}^{3,4,5}$ | Operating Power Supply Current | $V_{CC} = 3.3V$ | — | 380 | — | mA | |
| V_{BHT} | Bus Hold Trip Points | | $V_{IL} (MAX)$ | — | $V_{IH} (MIN)$ | V | |
| C_1 | I/O Capacitance ³ | $V_{CC} = 3.3V, V_{IO} = 0 \text{ to } V_{IH} (MAX)$ | — | 10 | — | pf | |
| | | $V_{CCO} = 3.3V, 2.5, 1.8, 1.5$ | | | | | |
| C_2 | Clock Capacitance ³ | $V_{CC} = 3.3V, V_{IO} = 0 \text{ to } V_{IH} (MAX)$ | — | 10 | — | pf | |
| | | $V_{CCO} = 3.3V, 2.5, 1.8, 1.5$ | | | | | |
| C_3 | Global Input Capacitance ³ | $V_{CC} = 3.3V, V_{IO} = 0 \text{ to } V_{IH} (MAX)$ | — | 10 | — | pf | |
| | | $V_{CCO} = 3.3V, 2.5, 1.8, 1.5$ | | | | | |

1. Input or I/O leakage current is measured with the pin configured as an input or as an I/O with the output driver tri-stated. It is not measured with the output driver active. Bus maintenance circuits are disabled.

2. Only available for LVCMOS and LVTTL standards.

3. $T_A = 25^\circ C$, $f = 1.0MHz$.

4. Device configured with 16-bit counters.

5. I_{CC} varies with specific device configuration and operating frequency.

sysIO Recommended Operating Conditions²

| Standard | V _{CCO} (V) | | V _{REF} (V) | |
|--------------------------|----------------------|------|----------------------|-------|
| | Min | Max | Min | Max |
| LVC MOS 3.3 ¹ | 3.0 | 3.6 | — | — |
| LVC MOS 2.5 | 2.3 | 2.7 | — | — |
| LVC MOS 1.8 | 1.65 | 1.95 | — | — |
| LV TTL | 3.0 | 3.6 | — | — |
| PCI 3.3 | 3.0 | 3.6 | — | — |
| PCI-X | 3.0 | 3.6 | — | — |
| AGP-1X | 3.15 | 3.45 | — | — |
| SSTL 2 | 2.3 | 2.7 | 1.15 | 1.35 |
| SSTL 3 | 3.0 | 3.6 | 1.3 | 1.7 |
| CTT 3.3 | 3.0 | 3.6 | 1.35 | 1.65 |
| CTT 2.5 | 2.3 | 2.7 | 1.35 | 1.65 |
| HSTL | 1.4 | 1.6 | 0.68 | 0.9 |
| GTL+ | 1.4 | 3.6 | 0.882 | 1.122 |

1. Software default setting.

2. Typical values for V_{CCO} and V_{REF} are the average of the Min and Max values.

sysIO DC Electrical Characteristics

Over Recommended Operating Conditions

| Standard | V_{IL} | | V_{IH} | | V_{OL} Max (V) | V_{OH} Min (V) | I_{OL}^2 (mA) | I_{OH}^2 (mA) |
|-------------------------|----------|------------------|------------------|---------|---------------------|---------------------|--------------------|-------------------------|
| | Min (V) | Max (V) | Min (V) | Max (V) | | | | |
| LVCMOS 3.3 ¹ | -0.3 | 0.8 | 2.0 | 5.5 | 0.4 | 2.4 | 20 | -20 |
| LVCMOS 3.3 | -0.3 | 0.8 | 2.0 | 5.5 | 0.4 | 2.4 | 16, 12, 8, 5.33, 4 | -16, -12, -8, -5.33, -4 |
| | | | | | 0.2 | $V_{CCO} - 0.2$ | 0.1 | -0.1 |
| LVTTTL | -0.3 | 0.8 | 2.0 | 5.5 | 0.4 | 2.4 | 20 | -20 |
| | | | | | 0.2 | $V_{CCO} - 0.2$ | 0.1 | -0.1 |
| LVCMOS 2.5 | -0.3 | 0.7 | 1.7 | 3.6 | 0.4 | $V_{CCO} - 0.4$ | 16, 12, 8, 5.33, 4 | -16, -12, -8, -5.33, -4 |
| | | | | | 0.2 | $V_{CCO} - 0.2$ | 0.1 | -0.1 |
| LVCMOS 1.8 | -0.3 | $0.35V_{CCO}$ | $0.65V_{CCO}$ | 3.6 | 0.4 | $V_{CCO} - 0.4$ | 12, 8, 5.33, 4 | -12, -8, -5.33, -4 |
| | | | | | 0.2 | $V_{CCO} - 0.2$ | 0.1 | -0.1 |
| PCI 3.3 | -0.3 | $0.3V_{CCO}$ | $0.5V_{CCO}$ | 3.6 | $0.1V_{CCO}$ | $0.9V_{CCO}$ | 1.5 | -0.5 |
| PCI-X | -0.3 | $0.35V_{CCO}$ | $0.5V_{CCO}$ | 3.6 | $0.1V_{CCO}$ | $0.9V_{CCO}$ | 1.5 | -0.5 |
| AGP-1X | -0.3 | $0.3V_{CCO}$ | $0.5V_{CCO}$ | 3.6 | $0.1V_{CCO}$ | $0.9V_{CCO}$ | 1.5 | -0.5 |
| SSTL3 class I | -0.3 | $V_{REF} - 0.2$ | $V_{REF} + 0.2$ | 3.6 | 0.7 | $V_{CCO} - 1.1$ | 8 | -8 |
| SSTL3 class II | -0.3 | $V_{REF} - 0.2$ | $V_{REF} + 0.2$ | 3.6 | 0.5 | $V_{CCO} - 0.9$ | 16 | -16 |
| SSTL2 class I | -0.3 | $V_{REF} - 0.18$ | $V_{REF} + 0.18$ | 3.6 | 0.54 | $V_{CCO} - 0.62$ | 7.6 | -7.6 |
| SSTL2 class II | -0.3 | $V_{REF} - 0.18$ | $V_{REF} + 0.18$ | 3.6 | 0.35 | $V_{CCO} - 0.43$ | 15.2 | -15.2 |
| CTT 3.3 | -0.3 | $V_{REF} - 0.2$ | $V_{REF} + 0.2$ | 3.6 | $V_{REF} - 0.4$ | $V_{REF} + 0.4$ | 8 | -8 |
| CTT 2.5 | -0.3 | $V_{REF} - 0.2$ | $V_{REF} + 0.2$ | 3.6 | $V_{REF} - 0.4$ | $V_{REF} + 0.4$ | 8 | -8 |
| HSTL class I | -0.3 | $V_{REF} - 0.1$ | $V_{REF} + 0.1$ | 3.6 | 0.4 | $V_{CCO} - 0.4$ | 8 | -8 |
| HSTL class III | -0.3 | $V_{REF} - 0.1$ | $V_{REF} + 0.1$ | 3.6 | 0.4 | $V_{CCO} - 0.4$ | 24 | -8 |
| GTL+ | -0.3 | $V_{REF} - 0.2$ | $V_{REF} + 0.2$ | 3.6 | 0.6 | n/a | 36 | n/a |

1. Software default setting

2. The average DC current drawn by I/Os between adjacent bank GND connections, or between the last GND in an I/O bank and the end of the I/O bank, as shown in the logic signals connection table, shall not exceed 96mA.

sysIO Differential Input DC Electrical Characteristics and Operating Conditions

| Symbol | Parameter | Test Conditions | Min | Max |
|-------------------------|-----------------------------------|---------------------------------|--------------------|-----------------|
| $V_{INP} \cdot V_{INM}$ | LVDS Input voltage | — | 0 | 2.4 |
| V_{THD} | LVDS Differential input threshold | — | $\pm 100\text{mV}$ | — |
| V_{IL} | LVPECL Input Voltage Low | $V_{CC} = 3.0$ to 3.6V | $V_{CC} - 1.81$ | $V_{CC} - 1.48$ |
| | | $V_{CC} = 3.3\text{V}$ | 1.49V | 1.83V |
| V_{IH} | LVPECL Input Voltage High | $V_{CC} = 3.0$ to 3.6V | $V_{CC} - 1.17$ | $V_{CC} - 0.88$ |
| | | $V_{CC} = 3.3\text{V}$ | 2.14V | 2.42V |

ispMACH 5768VG External Switching Characteristics

Over Recommended Operating Conditions

| Parameter | Description ^{1,2,3} | -5 | | -75 | | -10 | | -12 | | Units |
|-------------------------------|---|-------|------|-------|-------|-------|------|-------|------|-------|
| | | Min | Max | Min | Max | Min | Max | Min | Max | |
| t _{PD} | Data propagation delay, 5-PT bypass | — | 5.0 | — | 7.5 | — | 10.0 | — | 12.0 | ns |
| t _{PD_PTSA} | Data propagation delay, intrasegment path | — | 6.0 | — | 9.0 | — | 11.5 | — | 13.5 | ns |
| t _{PD_GLOBAL} | Data propagation delay, intersegment path | — | 6.5 | — | 9.75 | — | 13.0 | — | 16.0 | ns |
| t _S | GLB register setup time before clock, 5-PT bypass | 3.0 | — | 5.0 | — | 7.5 | — | 9.3 | — | ns |
| t _{S_PTSA} | GLB register setup time before clock | 3.0 | — | 6.0 | — | 8.5 | — | 10.0 | — | ns |
| t _{SIR} | GLB register setup time before clock, input register path | 2.8 | — | 3.0 | — | 4.0 | — | 5.0 | — | ns |
| t _H | GLB register hold time before clock, 5-PT bypass | 0.0 | — | 0.0 | — | 0.0 | — | 0.0 | — | ns |
| t _{H_PTSA} | GLB register hold time before clock | 0.0 | — | 0.0 | — | 0.0 | — | 0.0 | — | ns |
| t _{HIR} | GLB register hold time before clock, input reg. path | 0.0 | — | 0.0 | — | 0.0 | — | 0.0 | — | ns |
| t _{CO} | GLB register clock-to-output delay | — | 4.4 | — | 5.0 | — | 6.0 | — | 7.0 | ns |
| t _R | External reset pin to output delay | — | 6.5 | — | 9.0 | — | 10.0 | — | 10.9 | ns |
| t _{RW} | External reset pulse duration | 4.0 | — | 6.0 | — | 8.0 | — | 9.5 | — | ns |
| t _{LPTOE/DIS} | Input to output local product term output enable/disable | — | 7.0 | — | 9.75 | — | 11.5 | — | 13.4 | ns |
| t _{SPTOE/DIS} | Input to output segment product term output enable/disable | — | 8.0 | — | 11.25 | — | 17.5 | — | 20.4 | ns |
| t _{GOE/DIS} | Global OE input to output enable/disable | — | 6.2 | — | 7.5 | — | 8.85 | — | 10.0 | ns |
| t _{CW} | Global clock width, high or low | 1.6 | — | 2.75 | — | 3.6 | — | 4.3 | — | ns |
| t _{GW} | Global gate width low (for low transparent) or high (for high transparent) | 1.8 | — | 2.75 | — | 3.6 | — | 4.3 | — | ns |
| t _{WIR} | Input register clock width, high or low | 1.8 | — | 2.75 | — | 3.6 | — | 4.3 | — | ns |
| t _{SKEW} | Clock-to-out skew, block level | — | 0.25 | — | 0.35 | — | 0.45 | — | 0.55 | ns |
| | Clock-to-out skew, segment level | — | 0.4 | — | 0.5 | — | 0.6 | — | 0.7 | ns |
| f _{MAX} ⁴ | Clock frequency with internal feedback | 178.6 | — | 117.0 | — | 87.0 | — | 73.0 | — | MHz |
| f _{MAX} (Ext.) | Clock frequency with external feedback, 1/ (t _{S_PTSA} + t _{CO}) | 135.1 | — | 90.9 | — | 69.0 | — | 58.8 | — | MHz |
| f _{MAX} (Tog.) | Clock frequency max Toggle | 312.5 | — | 181.0 | — | 138.0 | — | 116.0 | — | MHz |

Timing v.1.20

1. Timing numbers are based on default LVCMOS 3.3 I/O Buffers. Use timing adjusters provided to calculate timing for other standards.
2. Measured using standard switching circuit, assuming segment and global routing loading of 1, worst case PTSA loading and 1 output switching.
3. Pulse widths and clock widths less than minimum will cause unknown behavior.
4. Standard 16-bit counter using SRP feedback.

ispMACH 51024VG External Switching Characteristics

Over Recommended Operating Conditions

| Parameter | Description ^{1,2,3} | -5 | | -75 | | -10 | | -12 | | Units |
|-------------------------------|--|-------|------|-------|-------|-------|------|-------|------|-------|
| | | Min | Max | Min | Max | Min | Max | Min | Max | |
| t _{PD} | Data propagation delay, 5-PT bypass | — | 5.0 | — | 7.5 | — | 10.0 | — | 12.0 | ns |
| t _{PD_PTSA} | Data propagation delay, intrasegment path | — | 6.0 | — | 9.0 | — | 11.5 | — | 13.5 | ns |
| t _{PD_GLOBAL} | Data propagation delay, intersegment path | — | 6.5 | — | 9.75 | — | 13.0 | — | 16.0 | ns |
| t _S | GLB register setup time before clock, 5-PT bypass | 3.0 | — | 5.0 | — | 7.5 | — | 9.3 | — | ns |
| t _{S_PTSA} | GLB register setup time before clock | 3.0 | — | 6.0 | — | 8.5 | — | 10.0 | — | ns |
| t _{SIR} | GLB register setup time before clock, input register path | 2.8 | — | 3.0 | — | 4.0 | — | 5.0 | — | ns |
| t _H | GLB register hold time before clock, 5-PT bypass | 0.0 | — | 0.0 | — | 0.0 | — | 0.0 | — | ns |
| t _{H_PTSA} | GLB register hold time before clock | 0.0 | — | 0.0 | — | 0.0 | — | 0.0 | — | ns |
| t _{HIR} | GLB register hold time before clock, input reg. path | 0.0 | — | 0.0 | — | 0.0 | — | 0.0 | — | ns |
| t _{CO} | GLB register clock-to-output delay | — | 4.4 | — | 5.0 | — | 6.0 | — | 7.0 | ns |
| t _R | External reset pin to output delay | — | 6.5 | — | 9.0 | — | 10.0 | — | 10.9 | ns |
| t _{RW} | External reset pulse duration | 4.0 | — | 6.0 | — | 8.0 | — | 9.5 | — | ns |
| t _{LPTOE/DIS} | Input to output local product term output enable/disable | — | 7.0 | — | 9.75 | — | 11.5 | — | 13.4 | ns |
| t _{SPTOE/DIS} | Input to output segment product term output enable/disable | — | 8.0 | — | 11.25 | — | 17.5 | — | 20.4 | ns |
| t _{GOE/DIS} | Global OE input to output enable/disable | — | 6.2 | — | 7.5 | — | 8.85 | — | 10.0 | ns |
| t _{CW} | Global clock width, high or low | 1.6 | — | 2.75 | — | 3.6 | — | 4.3 | — | ns |
| t _{GW} | Global gate width low (for low transparent) or high (for high transparent) | 1.8 | — | 2.75 | — | 3.6 | — | 4.3 | — | ns |
| t _{WIR} | Input register clock width, high or low | 1.8 | — | 2.75 | — | 3.6 | — | 4.3 | — | ns |
| t _{SKEW} | Clock-to-out skew, block level | — | 0.25 | — | 0.35 | — | 0.45 | — | 0.55 | ns |
| | Clock-to-out skew, segment level | — | 0.4 | — | 0.5 | — | 0.6 | — | 0.7 | ns |
| f _{MAX} ⁴ | Clock frequency with internal feedback | 178.6 | — | 117.0 | — | 87.0 | — | 73.0 | — | MHz |
| f _{MAX} (Ext.) | Clock frequency with external feedback, 1/(t _{S_PTSA} + t _{CO}) | 135.1 | — | 90.9 | — | 69.0 | — | 58.8 | — | MHz |
| f _{MAX} (Tog.) | Clock frequency max Toggle | 312.5 | — | 181.0 | — | 138.0 | — | 116.0 | — | MHz |

Timing v.1.10

1. Timing numbers are based on default LVCMOS 3.3 I/O Buffers. Use timing adjusters provided to calculate timing for other standards.
2. Measured using standard switching circuit, assuming segment and global routing loading of 1, worst case PTSA loading and 1 output switching.
3. Pulse widths and clock widths less than minimum will cause unknown behavior.
4. Standard 16-bit counter using SRP feedback.

Timing Model

The task of determining the timing through the ispMACH 5000VG family, like any CPLD, is relatively simple. The timing model provided in Figure 11 shows the specific delay paths. Once the implementation of a given function is determined either conceptually or from the software report file, the delay path of the function can easily be determined from the timing model. The Lattice design tools report the timing delays based on the same timing model for a particular design. Note that the internal timing parameters are given for reference only, and are not tested. The external timing parameters are tested and guaranteed for every device. For more information on the timing model and usage, please refer to Technical Note TN1001: *ispMACH 5000VG Timing Model Design and Usage Guidelines*.

Figure 11. ispMACH 5000VG Timing Model

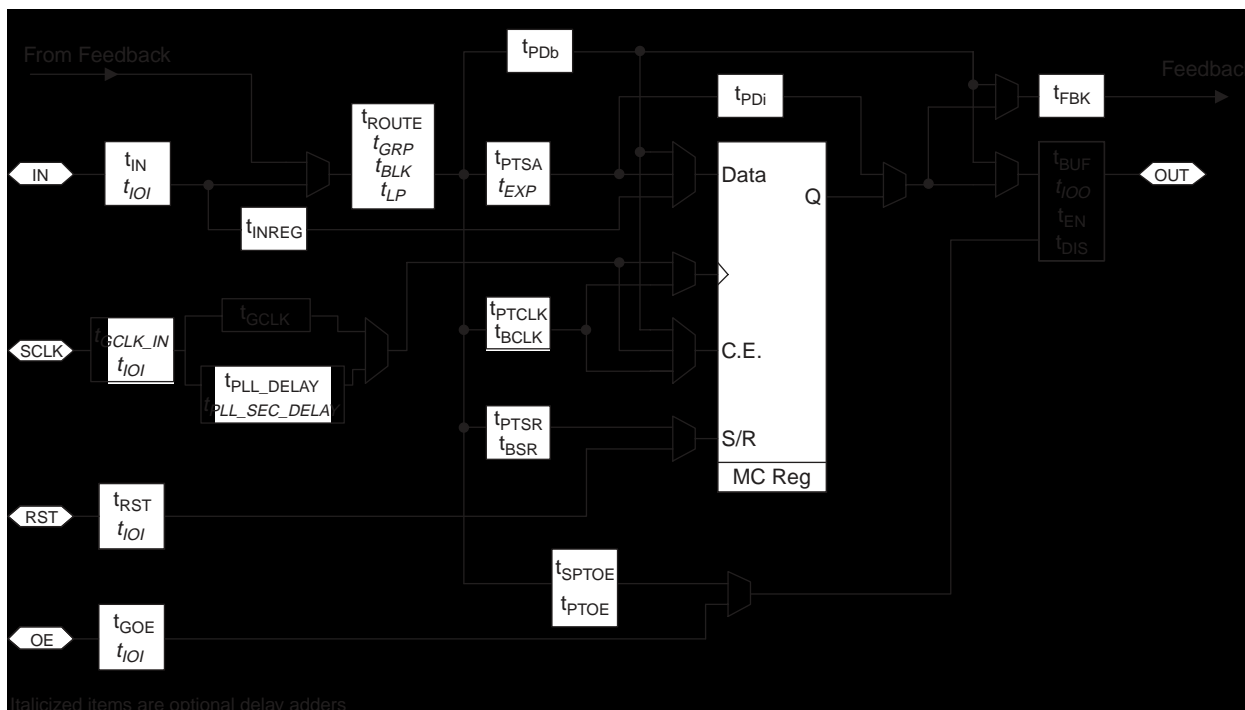

ispMACH 5768VG Internal Timing Parameters

Over Recommended Operating Conditions

| Parameter | Description | -5 | | -75 | | -10 | | -12 | | Units |
|------------------------------|--|------|------|------|------|------|------|------|------|-------|
| | | Min | Max | Min | Max | Min | Max | Min | Max | |
| In/Out Delays | | | | | | | | | | |
| t_{IN} | Input Buffer Delay | — | 0.65 | — | 0.95 | — | 1.25 | — | 1.40 | ns |
| t_{GCLK_IN} | Global Clock Input Buffer Delay | — | 0.65 | — | 0.95 | — | 1.25 | — | 1.40 | ns |
| t_{GOE} | Global OE Pin Delay | — | 4.05 | — | 5.00 | — | 6.00 | — | 7.00 | ns |
| t_{BUF} | Delay through Output Buffer | — | 1.15 | — | 1.50 | — | 1.75 | — | 1.90 | ns |
| t_{EN} | Output Enable Time | — | 2.15 | — | 2.50 | — | 2.85 | — | 3.00 | ns |
| t_{DIS} | Output Disable Time | — | 2.15 | — | 2.50 | — | 2.85 | — | 3.00 | ns |
| t_{RSTb} | Global RESETbar Pin Delay | — | 4.60 | — | 6.50 | — | 7.00 | — | 7.50 | ns |
| Routing Delays | | | | | | | | | | |
| t_{ROUTE} | Delay through SRP | — | 2.80 | — | 4.20 | — | 5.65 | — | 6.90 | ns |
| t_{PTSA} | Product Term Sharing Array Delay | — | 0.40 | — | 1.85 | — | 2.35 | — | 2.50 | ns |
| t_{PDB} | 5-PT Bypass Propagation Delay | — | 0.40 | — | 0.85 | — | 1.35 | — | 1.80 | ns |
| t_{PDi} | Macrocell Propagation Delay | — | 1.00 | — | 0.50 | — | 0.50 | — | 0.80 | ns |
| t_{INREG} | Input Buffer to Macrocell Register Delay | — | 3.00 | — | 3.05 | — | 3.50 | — | 4.40 | ns |
| t_{FBK} | Internal Feedback Delay | — | 0.00 | — | 0.00 | — | 0.00 | — | 0.00 | ns |
| t_{GCLK} | Global Clock Tree Delay | — | 0.85 | — | 0.70 | — | 0.55 | — | 0.65 | ns |
| t_{PLL_DELAY} | Programmable PLL Delay Increment | — | 0.50 | — | 0.50 | — | 0.50 | — | 0.50 | ns |
| $t_{PLL_SEC_DELAY}$ | Additional Delay When Using Secondary PLL Output | — | 0.60 | — | 0.60 | — | 0.60 | — | 0.60 | ns |
| t_{GRP} | Global Routing Pool Delay | — | 1.50 | — | 2.25 | — | 3.00 | — | 4.00 | ns |
| Register/Latch Delays | | | | | | | | | | |
| t_S | D-Register Setup Time | 0.65 | — | 0.65 | — | 1.05 | — | 1.25 | — | ns |
| t_{S_PT} | D-Register Setup Time with PT Clock | 0.65 | — | 0.65 | — | 1.05 | — | 1.25 | — | ns |
| t_H | D-Register Hold Time | 0.00 | — | 0.00 | — | 0.00 | — | 0.00 | — | ns |
| t_{ST} | T-Register Setup Time | 1.15 | — | 1.15 | — | 1.55 | — | 1.75 | — | ns |
| t_{ST_PT} | T-Register Setup Time with PT Clock | 1.15 | — | 1.15 | — | 1.55 | — | 1.75 | — | ns |
| t_{HT} | T-Register Hold Time | 0.00 | — | 0.00 | — | 0.00 | — | 0.00 | — | ns |
| t_{COi} | Register Clock to Output/Feedback MUX Time | — | 1.75 | — | 1.85 | — | 2.45 | — | 3.05 | ns |
| t_{CES} | Clock Enable Setup Time | 2.60 | — | 3.90 | — | 5.05 | — | 5.95 | — | ns |
| t_{CEH} | Clock Enable Hold Time | 0.60 | — | 0.90 | — | 1.20 | — | 1.45 | — | ns |
| t_{SL} | Latch Setup Time | 2.80 | — | 4.20 | — | 5.50 | — | 6.60 | — | ns |
| t_{SL_PT} | Latch Setup Time with PT Clock | 2.80 | — | 4.20 | — | 5.50 | — | 6.60 | — | ns |
| t_{HL} | Latch Hold Time | 0.00 | — | 0.00 | — | 0.00 | — | 0.00 | — | ns |
| t_{GOi} | Latch Gate to Output/Feedback MUX Time | — | 1.75 | — | 2.50 | — | 3.50 | — | 4.50 | ns |
| t_{PDLi} | Propagation Delay through Transparent Latch to Output/Feedback MUX | — | 2.40 | — | 3.50 | — | 4.00 | — | 4.50 | ns |
| t_{SRi} | Asynchronous Reset or Set to Output/Feedback MUX Delay | — | 0.75 | — | 1.00 | — | 1.25 | — | 1.50 | ns |
| t_{SRR} | Asynchronous Reset or Set Recovery Delay | — | 1.00 | — | 1.50 | — | 2.00 | — | 2.50 | ns |
| Control Delays | | | | | | | | | | |
| t_{BCLK} | GLB PT Clock Delay | — | 3.10 | — | 4.65 | — | 6.00 | — | 7.00 | ns |
| t_{PTCLK} | Macrocell PT Clock Delay | — | 3.00 | — | 4.50 | — | 6.00 | — | 7.00 | ns |

ispMACH 5768VG Internal Timing Parameters (Continued)

Over Recommended Operating Conditions

| Parameter | Description | -5 | | -75 | | -10 | | -12 | | Units |
|--------------------|------------------------------|-----|------|-----|------|-----|------|-----|------|-------|
| | | Min | Max | Min | Max | Min | Max | Min | Max | |
| t _{BSR} | Block PT Set/Reset Delay | — | 2.00 | — | 3.00 | — | 4.00 | — | 4.80 | ns |
| t _{PTSR} | Macrocell PT Set/Reset Delay | — | 2.00 | — | 3.00 | — | 4.00 | — | 4.80 | ns |
| t _{SPTOE} | Segment PT OE Delay | — | 2.40 | — | 3.60 | — | 7.75 | — | 9.10 | ns |
| t _{PTOE} | Macrocell PT OE Delay | — | 1.40 | — | 2.10 | — | 1.75 | — | 2.10 | ns |

Notes:

Timing v.1.20

1. Internal Timing Parameters are not tested and are for reference only. Refer to Timing Model in this data sheet for further details.
2. t_{PLL_DELAY} is the unit increment by which the clock signal can be incremented. The PLL can adjust the clock signal by up to 3.5ns in either direction in units of 0.5ns for each step.

ispMACH 51024VG Internal Timing Parameters

Over Recommended Operating Conditions

| Parameter | Description | -5 | | -75 | | -10 | | -12 | | Units |
|------------------------------|--|------|------|------|------|------|------|------|------|-------|
| | | Min | Max | Min | Max | Min | Max | Min | Max | |
| In/Out Delays | | | | | | | | | | |
| t _{IN} | Input Buffer Delay | — | 0.65 | — | 0.95 | — | 1.25 | — | 1.40 | ns |
| t _{GCLK_IN} | Global Clock Input Buffer Delay | — | 0.65 | — | 0.95 | — | 1.25 | — | 1.40 | ns |
| t _{GOE} | Global OE Pin Delay | — | 4.05 | — | 5.00 | — | 6.00 | — | 7.00 | ns |
| t _{BUF} | Delay through Output Buffer | — | 1.15 | — | 1.50 | — | 1.75 | — | 1.90 | ns |
| t _{EN} | Output Enable Time | — | 2.15 | — | 2.50 | — | 2.85 | — | 3.00 | ns |
| t _{DIS} | Output Disable Time | — | 2.15 | — | 2.50 | — | 2.85 | — | 3.00 | ns |
| t _{RSTb} | Global RESETbar Pin Delay | — | 4.60 | — | 6.50 | — | 7.00 | — | 7.50 | ns |
| Routing Delays | | | | | | | | | | |
| t _{ROUTE} | Delay through SRP | — | 2.80 | — | 4.20 | — | 5.65 | — | 6.90 | ns |
| t _{PTSA} | Product Term Sharing Array Delay | — | 0.40 | — | 1.85 | — | 2.35 | — | 2.50 | ns |
| t _{PDB} | 5-PT Bypass Propagation Delay | — | 0.40 | — | 0.85 | — | 1.35 | — | 1.80 | ns |
| t _{PDi} | Macrocell Propagation Delay | — | 1.00 | — | 0.50 | — | 0.50 | — | 0.80 | ns |
| t _{INREG} | Input Buffer to Macrocell Register Delay | — | 3.00 | — | 3.05 | — | 3.50 | — | 4.40 | ns |
| t _{FBK} | Internal Feedback Delay | — | 0.00 | — | 0.00 | — | 0.00 | — | 0.00 | ns |
| t _{GCLK} | Global Clock Tree Delay | — | 0.85 | — | 0.70 | — | 0.55 | — | 0.65 | ns |
| t _{PLL_DELAY} | Programmable PLL Delay Increment | — | 0.50 | — | 0.50 | — | 0.50 | — | 0.50 | ns |
| t _{PLL_SEC_DELAY} | Additional Delay When Using Secondary PLL Output | — | 0.60 | — | 0.60 | — | 0.60 | — | 0.60 | ns |
| t _{GRP} | Global Routing Pool Delay | — | 1.50 | — | 2.25 | — | 3.00 | — | 4.00 | ns |
| Register/Latch Delays | | | | | | | | | | |
| t _S | D-Register Setup Time | 0.65 | — | 0.65 | — | 1.05 | — | 1.25 | — | ns |
| t _{S_PT} | D-Register Setup Time with PT Clock | 0.65 | — | 0.65 | — | 1.05 | — | 1.25 | — | ns |
| t _H | D-Register Hold Time | 0.00 | — | 0.00 | — | 0.00 | — | 0.00 | — | ns |
| t _{ST} | T-Register Setup Time | 1.15 | — | 1.15 | — | 1.55 | — | 1.75 | — | ns |
| t _{ST_PT} | T-Register Setup Time with PT Clock | 1.15 | — | 1.15 | — | 1.55 | — | 1.75 | — | ns |
| t _{HT} | T-Register Hold Time | 0.00 | — | 0.00 | — | 0.00 | — | 0.00 | — | ns |
| t _{COi} | Register Clock to Output/Feedback MUX Time | — | 1.75 | — | 1.85 | — | 2.45 | — | 3.05 | ns |

ispMACH 51024VG Internal Timing Parameters (Continued)

Over Recommended Operating Conditions

| Parameter | Description | -5 | | -75 | | -10 | | -12 | | Units |
|-----------------------|--|------|------|------|------|------|------|------|------|-------|
| | | Min | Max | Min | Max | Min | Max | Min | Max | |
| t _{CES} | Clock Enable Setup Time | 2.60 | — | 3.90 | — | 5.05 | — | 5.95 | — | ns |
| t _{CEH} | Clock Enable Hold Time | 0.60 | — | 0.90 | — | 1.20 | — | 1.45 | — | ns |
| t _{SL} | Latch Setup Time | 2.80 | — | 4.20 | — | 5.50 | — | 6.60 | — | ns |
| t _{SL_PT} | Latch Setup Time with PT Clock | 2.80 | — | 4.20 | — | 5.50 | — | 6.60 | — | ns |
| t _{HL} | Latch Hold Time | 0.00 | — | 0.00 | — | 0.00 | — | 0.00 | — | ns |
| t _{GOi} | Latch Gate to Output/Feedback MUX Time | — | 1.75 | — | 2.50 | — | 3.50 | — | 4.50 | ns |
| t _{PDLi} | Propagation Delay through Transparent Latch to Output/Feedback MUX | — | 2.40 | — | 3.50 | — | 4.00 | — | 4.50 | ns |
| t _{SRI} | Asynchronous Reset or Set to Output/Feedback MUX Delay | — | 0.75 | — | 1.00 | — | 1.25 | — | 1.50 | ns |
| t _{SRR} | Asynchronous Reset or Set Recovery Delay | — | 1.00 | — | 1.50 | — | 2.00 | — | 2.50 | ns |
| Control Delays | | | | | | | | | | |
| t _{BCLK} | GLB PT Clock Delay | — | 3.10 | — | 4.65 | — | 6.00 | — | 7.00 | ns |
| t _{PTCLK} | Macrocell PT Clock Delay | — | 3.00 | — | 4.50 | — | 6.00 | — | 7.00 | ns |
| t _{BSR} | Block PT Set/Reset Delay | — | 2.00 | — | 3.00 | — | 4.00 | — | 4.80 | ns |
| t _{PTSR} | Macrocell PT Set/Reset Delay | — | 2.00 | — | 3.00 | — | 4.00 | — | 4.80 | ns |
| t _{SPTOE} | Segment PT OE Delay | — | 2.40 | — | 3.60 | — | 7.75 | — | 9.10 | ns |
| t _{PTOE} | Macrocell PT OE Delay | — | 1.40 | — | 2.10 | — | 1.75 | — | 2.10 | ns |

Notes:

Timing v.1.10

- Internal Timing Parameters are not tested and are for reference only. Refer to Timing Model in this data sheet for further details.
- t_{PLL_DELAY} is the unit increment by which the clock signal can be incremented. The PLL can adjust the clock signal by up to 3.5ns in either direction in units of 0.5ns for each step.

ispMACH 5768VG Timing Adders

| Adder Type | Base Parameter | Description | -5 | | -75 | | -10 | | -12 | | Units |
|---|---|---|-----|------|-----|------|-----|------|-----|------|-------|
| | | | Min | Max | Min | Max | Min | Max | Min | Max | |
| t_{BLA} | t_{ROUTE} | GLB Loading Adder | — | 0.0 | — | 0.0 | — | 0.0 | — | 0.0 | ns |
| t_{EXP} | t_{PTSA} | PT Expander Adder | — | 1.5 | — | 2.0 | — | 2.5 | — | 2.5 | ns |
| t_{LP} | t_{ROUTE} | Low Power Adder | — | 1.5 | — | 1.5 | — | 1.5 | — | 1.5 | ns |
| t_{IOI} Input Adders | | | | | | | | | | | |
| LVC MOS18_in | $t_{IN}, t_{GCLK_IN}, t_{RSTb}, t_{GOE}$ | Using LVC MOS1.8 standard | — | 0.90 | — | 0.90 | — | 0.90 | — | 0.90 | ns |
| LVC MOS25_in | $t_{IN}, t_{GCLK_IN}, t_{RSTb}, t_{GOE}$ | Using LVC MOS2.5 standard | — | 0.15 | — | 0.15 | — | 0.15 | — | 0.15 | ns |
| LVC MOS33_in | $t_{IN}, t_{GCLK_IN}, t_{RSTb}, t_{GOE}$ | Using LVC MOS3.3 standard | — | 0.0 | — | 0.0 | — | 0.0 | — | 0.0 | ns |
| LVTTL | $t_{IN}, t_{GCLK_IN}, t_{RSTb}, t_{GOE}$ | Using LVTTL standard | — | 0.0 | — | 0.0 | — | 0.0 | — | 0.0 | ns |
| PCI_in | $t_{IN}, t_{GCLK_IN}, t_{RSTb}, t_{GOE}$ | Using PCI standard | — | 0.0 | — | 0.0 | — | 0.0 | — | 0.0 | ns |
| PCI_X_in | $t_{IN}, t_{GCLK_IN}, t_{RSTb}, t_{GOE}$ | Using PCI_X standard | — | 0.0 | — | 0.0 | — | 0.0 | — | 0.0 | ns |
| AGP_1X_in | $t_{IN}, t_{GCLK_IN}, t_{RSTb}, t_{GOE}$ | Using AGP-1X standard | — | 0.0 | — | 0.0 | — | 0.0 | — | 0.0 | ns |
| SSTL3_I_in | $t_{IN}, t_{GCLK_IN}, t_{RSTb}, t_{GOE}$ | Using SSTL3_I standard | — | 1.00 | — | 1.00 | — | 1.00 | — | 1.00 | ns |
| SSTL3_II_in | $t_{IN}, t_{GCLK_IN}, t_{RSTb}, t_{GOE}$ | Using SSTL3_II standard | — | 1.00 | — | 1.00 | — | 1.00 | — | 1.00 | ns |
| SSTL2_I_in | $t_{IN}, t_{GCLK_IN}, t_{RSTb}, t_{GOE}$ | Using SSTL2_I standard | — | 1.00 | — | 1.00 | — | 1.00 | — | 1.00 | ns |
| SSTL2_II_in | $t_{IN}, t_{GCLK_IN}, t_{RSTb}, t_{GOE}$ | Using SSTL2_II standard | — | 1.00 | — | 1.00 | — | 1.00 | — | 1.00 | ns |
| CTT33_in | $t_{IN}, t_{GCLK_IN}, t_{RSTb}, t_{GOE}$ | Using CTT3.3 standard | — | 0.0 | — | 0.0 | — | 0.0 | — | 0.0 | ns |
| CTT25_in | $t_{IN}, t_{GCLK_IN}, t_{RSTb}, t_{GOE}$ | Using CTT2.5 standard | — | 0.15 | — | 0.15 | — | 0.15 | — | 0.15 | ns |
| HSTL_I_in | $t_{IN}, t_{GCLK_IN}, t_{RSTb}, t_{GOE}$ | Using HSTL_I standard | — | 1.25 | — | 1.25 | — | 1.25 | — | 1.25 | ns |
| HSTL_III_in | $t_{IN}, t_{GCLK_IN}, t_{RSTb}, t_{GOE}$ | Using HSTL_III standard | — | 1.25 | — | 1.25 | — | 1.25 | — | 1.25 | ns |
| GTL+_in | $t_{IN}, t_{GCLK_IN}, t_{RSTb}, t_{GOE}$ | Using GTL+ standard | — | 1.50 | — | 1.50 | — | 1.50 | — | 1.50 | ns |
| LVDS_in | t_{GCLK_IN} | Using LVDS standard | — | 1.70 | — | 1.70 | — | 1.70 | — | 1.70 | ns |
| LVPECL_in | t_{GCLK_IN} | Using LVPECL standard | — | 2.10 | — | 2.10 | — | 2.10 | — | 2.10 | ns |
| t_{IOO} Output Adders | | | | | | | | | | | |
| LVC MOS18_4mA_out | t_{BUF}, t_{EN}, t_{DIS} | Output configured as 1.8V & 4mA Buffer | — | 3.00 | — | 3.00 | — | 3.00 | — | 3.00 | ns |
| LVC MOS18_5mA_out | t_{BUF}, t_{EN}, t_{DIS} | Output configured as 1.8V & 5.33mA Buffer | — | 2.50 | — | 2.50 | — | 2.50 | — | 2.50 | ns |
| LVC MOS18_8mA_out | t_{BUF}, t_{EN}, t_{DIS} | Output configured as 1.8V & 8mA Buffer | — | 1.85 | — | 1.85 | — | 1.85 | — | 1.85 | ns |

Note: Open drain timing is the same as corresponding LVC MOS timing.

Timing v.1.20

ispMACH 5768VG Timing Adders (Continued)

| Adder Type | Base Parameter | Description | -5 | | -75 | | -10 | | -12 | | Units |
|--------------------|----------------------------------|---|-----|-------|-----|-------|-----|-------|-----|-------|-------|
| | | | Min | Max | Min | Max | Min | Max | Min | Max | |
| LVC MOS18_12mA_out | t_{BUF} , t_{EN} , t_{DIS} | Output configured as 1.8V & 12mA Buffer | — | 1.35 | — | 1.35 | — | 1.35 | — | 1.35 | ns |
| LVC MOS25_4mA_out | t_{BUF} , t_{EN} , t_{DIS} | Output configured as 2.5V & 4mA Buffer | — | 1.50 | — | 1.50 | — | 1.50 | — | 1.50 | ns |
| LVC MOS25_5mA_out | t_{BUF} , t_{EN} , t_{DIS} | Output configured as 2.5V & 5.33mA Buffer | — | 1.25 | — | 1.25 | — | 1.25 | — | 1.25 | ns |
| LVC MOS25_8mA_out | t_{BUF} , t_{EN} , t_{DIS} | Output configured as 2.5V & 8mA Buffer | — | 0.70 | — | 0.70 | — | 0.70 | — | 0.70 | ns |
| LVC MOS25_12mA_out | t_{BUF} , t_{EN} , t_{DIS} | Output configured as 2.5V & 12mA Buffer | — | 0.50 | — | 0.50 | — | 0.50 | — | 0.50 | ns |
| LVC MOS25_16mA_out | t_{BUF} , t_{EN} , t_{DIS} | Output configured as 2.5V & 16mA Buffer | — | 0.25 | — | 0.25 | — | 0.25 | — | 0.25 | ns |
| LVC MOS33_4mA_out | t_{BUF} , t_{EN} , t_{DIS} | Output configured as 3.3V & 4mA Buffer | — | 1.50 | — | 1.50 | — | 1.50 | — | 1.50 | ns |
| LVC MOS33_5mA_out | t_{BUF} , t_{EN} , t_{DIS} | Output configured as 3.3V & 5.33mA Buffer | — | 1.25 | — | 1.25 | — | 1.25 | — | 1.25 | ns |
| LVC MOS33_8mA_out | t_{BUF} , t_{EN} , t_{DIS} | Output configured as 3.3V & 8mA Buffer | — | 0.40 | — | 0.40 | — | 0.40 | — | 0.40 | ns |
| LVC MOS33_12mA_out | t_{BUF} , t_{EN} , t_{DIS} | Output configured as 3.3V & 12mA Buffer | — | 0.10 | — | 0.10 | — | 0.10 | — | 0.10 | ns |
| LVC MOS33_16mA_out | t_{BUF} , t_{EN} , t_{DIS} | Output configured as 3.3V & 16mA Buffer | — | 0.0 | — | 0.0 | — | 0.0 | — | 0.0 | ns |
| LVC MOS33_20mA_out | t_{BUF} , t_{EN} , t_{DIS} | Output configured as 3.3V & 20mA Buffer | — | 0.0 | — | 0.0 | — | 0.0 | — | 0.0 | ns |
| LV TTL | t_{BUF} , t_{EN} , t_{DIS} | Output configured as LV TTL Buffer | — | 0.0 | — | 0.0 | — | 0.0 | — | 0.0 | ns |
| Slow Slew | t_{BUF} , t_{EN} | Output configured for slow slew rate | — | 1.50 | — | 1.50 | — | 1.50 | — | 1.50 | ns |
| PCI_out | t_{BUF} , t_{EN} , t_{DIS} | Using PCI standard | — | 0.0 | — | 0.0 | — | 0.0 | — | 0.0 | ns |
| PCI_X_out | t_{BUF} , t_{EN} , t_{DIS} | Using PCI-X standard | — | 0.0 | — | 0.0 | — | 0.0 | — | 0.0 | ns |
| AGP_1X_out | t_{BUF} , t_{EN} , t_{DIS} | Using AGP-1X standard | — | 0.0 | — | 0.0 | — | 0.0 | — | 0.0 | ns |
| SSTL3_I_out | t_{BUF} , t_{EN} , t_{DIS} | Using SSTL3_I standard | — | -0.25 | — | -0.25 | — | -0.25 | — | -0.25 | ns |
| SSTL3_II_out | t_{BUF} , t_{EN} , t_{DIS} | Using SSTL3_II standard | — | -0.35 | — | -0.35 | — | -0.35 | — | -0.35 | ns |
| SSTL2_I_out | t_{BUF} , t_{EN} , t_{DIS} | Using SSTL2_I standard | — | 0.0 | — | 0.0 | — | 0.0 | — | 0.0 | ns |
| SSTL2_II_out | t_{BUF} , t_{EN} , t_{DIS} | Using SSTL2_II standard | — | -0.25 | — | -0.25 | — | -0.25 | — | -0.25 | ns |
| CTT33_out | t_{BUF} , t_{EN} , t_{DIS} | Using CCT3.3 standard | — | 0.0 | — | 0.0 | — | 0.0 | — | 0.0 | ns |
| CTT25_out | t_{BUF} , t_{EN} , t_{DIS} | Using CCT2.5 standard | — | 0.25 | — | 0.25 | — | 0.25 | — | 0.25 | ns |
| HSTL_I_out | t_{BUF} , t_{EN} , t_{DIS} | Using HSTL_I standard | — | -0.30 | — | -0.30 | — | -0.30 | — | -0.30 | ns |

Note: Open drain timing is the same as corresponding LVC MOS timing.

Timing v.1.20

ispMACH 5768VG Timing Adders (Continued)

| Adder Type | Base Parameter | Description | -5 | | -75 | | -10 | | -12 | | Units |
|--------------|----------------------------------|-------------------------|-----|------|-----|------|-----|------|-----|------|-------|
| | | | Min | Max | Min | Max | Min | Max | Min | Max | |
| HSTL_III_out | t_{BUF} , t_{EN} , t_{DIS} | Using HSTL_III standard | — | 0.00 | — | 0.00 | — | 0.00 | — | 0.00 | ns |
| GTL+_out | t_{BUF} , t_{EN} , t_{DIS} | Using GTL+ standard | — | 0.30 | — | 0.30 | — | 0.30 | — | 0.30 | ns |

Note: Open drain timing is the same as corresponding LVCMOS timing.

Timing v.1.20

ispMACH 51024VG Timing Adders

| Adder Type | Base Parameter | Description | -5 | | -75 | | -10 | | -12 | | Units |
|--|--|--------------------------|-----|------|-----|------|-----|------|-----|------|-------|
| | | | Min | Max | Min | Max | Min | Max | Min | Max | |
| t_{BLA} | t_{ROUTE} | GLB Loading Adder | — | 0.0 | — | 0.0 | — | 0.0 | — | 0.0 | ns |
| t_{EXP} | t_{PTSA} | PT Expander Adder | — | 1.5 | — | 2.0 | — | 2.5 | — | 2.5 | ns |
| t_{LP} | t_{ROUTE} | Low Power Adder | — | 1.5 | — | 1.5 | — | 1.5 | — | 1.5 | ns |
| t_{IOI} Input Adders | | | | | | | | | | | |
| LVC MOS18_in | t_{IN} , t_{GCLK_IN} , t_{RSTb} , t_{GOE} | Using LVCMOS1.8 standard | — | 0.90 | — | 0.90 | — | 0.90 | — | 0.90 | ns |
| LVC MOS25_in | t_{IN} , t_{GCLK_IN} , t_{RSTb} , t_{GOE} | Using LVCMOS2.5 standard | — | 0.15 | — | 0.15 | — | 0.15 | — | 0.15 | ns |
| LVC MOS33_in | t_{IN} , t_{GCLK_IN} , t_{RSTb} , t_{GOE} | Using LVCMOS3.3 standard | — | 0.0 | — | 0.0 | — | 0.0 | — | 0.0 | ns |
| LV TTL | t_{IN} , t_{GCLK_IN} , t_{RSTb} , t_{GOE} | Using LV TTL standard | — | 0.0 | — | 0.0 | — | 0.0 | — | 0.0 | ns |
| PCI_in | t_{IN} , t_{GCLK_IN} , t_{RSTb} , t_{GOE} | Using PCI standard | — | 0.0 | — | 0.0 | — | 0.0 | — | 0.0 | ns |
| PCI_X_in | t_{IN} , t_{GCLK_IN} , t_{RSTb} , t_{GOE} | Using PCI_X standard | — | 0.0 | — | 0.0 | — | 0.0 | — | 0.0 | ns |
| AGP_1X_in | t_{IN} , t_{GCLK_IN} , t_{RSTb} , t_{GOE} | Using AGP-1X standard | — | 0.0 | — | 0.0 | — | 0.0 | — | 0.0 | ns |
| SSTL3_I_in | t_{IN} , t_{GCLK_IN} , t_{RSTb} , t_{GOE} | Using SSTL3_I standard | — | 1.00 | — | 1.00 | — | 1.00 | — | 1.00 | ns |
| SSTL3_II_in | t_{IN} , t_{GCLK_IN} , t_{RSTb} , t_{GOE} | Using SSTL3_II standard | — | 1.00 | — | 1.00 | — | 1.00 | — | 1.00 | ns |
| SSTL2_I_in | t_{IN} , t_{GCLK_IN} , t_{RSTb} , t_{GOE} | Using SSTL2_I standard | — | 1.00 | — | 1.00 | — | 1.00 | — | 1.00 | ns |
| SSTL2_II_in | t_{IN} , t_{GCLK_IN} , t_{RSTb} , t_{GOE} | Using SSTL2_II standard | — | 1.00 | — | 1.00 | — | 1.00 | — | 1.00 | ns |
| CTT33_in | t_{IN} , t_{GCLK_IN} , t_{RSTb} , t_{GOE} | Using CTT3.3 standard | — | 0.0 | — | 0.0 | — | 0.0 | — | 0.0 | ns |
| CTT25_in | t_{IN} , t_{GCLK_IN} , t_{RSTb} , t_{GOE} | Using CTT2.5 standard | — | 0.15 | — | 0.15 | — | 0.15 | — | 0.15 | ns |
| HSTL_I_in | t_{IN} , t_{GCLK_IN} , t_{RSTb} , t_{GOE} | Using HSTL_I standard | — | 1.25 | — | 1.25 | — | 1.25 | — | 1.25 | ns |
| HSTL_III_in | t_{IN} , t_{GCLK_IN} , t_{RSTb} , t_{GOE} | Using HSTL_III standard | — | 1.25 | — | 1.25 | — | 1.25 | — | 1.25 | ns |
| GTL+_in | t_{IN} , t_{GCLK_IN} , t_{RSTb} , t_{GOE} | Using GTL+ standard | — | 1.50 | — | 1.50 | — | 1.50 | — | 1.50 | ns |

Note: Open drain timing is the same as corresponding LVCMOS timing.

Timing v.1.10

ispMACH 51024VG Timing Adders (Continued)

| Adder Type | Base Parameter | Description | -5 | | -75 | | -10 | | -12 | | Units |
|--------------------------------------|---|---|-----|-------|-----|-------|-----|-------|-----|-------|-------|
| | | | Min | Max | Min | Max | Min | Max | Min | Max | |
| LVDS_in | t _{GCLK_IN} | Using LVDS standard | — | 1.70 | — | 1.70 | — | 1.70 | — | 1.70 | ns |
| LVPECL_in | t _{GCLK_IN} | Using LVPECL standard | — | 2.10 | — | 2.10 | — | 2.10 | — | 2.10 | ns |
| t₁₀₀ Output Adders | | | | | | | | | | | |
| LVCMOS18_4mA_out | t _{BUF} , t _{EN} , t _{DIS} | Output configured as 1.8V & 4mA Buffer | — | 3.00 | — | 3.00 | — | 3.00 | — | 3.00 | ns |
| LVCMOS18_5mA_out | t _{BUF} , t _{EN} , t _{DIS} | Output configured as 1.8V & 5.33mA Buffer | — | 2.50 | — | 2.50 | — | 2.50 | — | 2.50 | ns |
| LVCMOS18_8mA_out | t _{BUF} , t _{EN} , t _{DIS} | Output configured as 1.8V & 8mA Buffer | — | 1.85 | — | 1.85 | — | 1.85 | — | 1.85 | ns |
| LVCMOS18_12mA_out | t _{BUF} , t _{EN} , t _{DIS} | Output configured as 1.8V & 12mA Buffer | — | 1.35 | — | 1.35 | — | 1.35 | — | 1.35 | ns |
| LVCMOS25_4mA_out | t _{BUF} , t _{EN} , t _{DIS} | Output configured as 2.5V & 4mA Buffer | — | 1.50 | — | 1.50 | — | 1.50 | — | 1.50 | ns |
| LVCMOS25_5mA_out | t _{BUF} , t _{EN} , t _{DIS} | Output configured as 2.5V & 5.33mA Buffer | — | 1.25 | — | 1.25 | — | 1.25 | — | 1.25 | ns |
| LVCMOS25_8mA_out | t _{BUF} , t _{EN} , t _{DIS} | Output configured as 2.5V & 8mA Buffer | — | 0.70 | — | 0.70 | — | 0.70 | — | 0.70 | ns |
| LVCMOS25_12mA_out | t _{BUF} , t _{EN} , t _{DIS} | Output configured as 2.5V & 12mA Buffer | — | 0.50 | — | 0.50 | — | 0.50 | — | 0.50 | ns |
| LVCMOS25_16mA_out | t _{BUF} , t _{EN} , t _{DIS} | Output configured as 2.5V & 16mA Buffer | — | 0.25 | — | 0.25 | — | 0.25 | — | 0.25 | ns |
| LVCMOS33_4mA_out | t _{BUF} , t _{EN} , t _{DIS} | Output configured as 3.3V & 4mA Buffer | — | 1.50 | — | 1.50 | — | 1.50 | — | 1.50 | ns |
| LVCMOS33_5mA_out | t _{BUF} , t _{EN} , t _{DIS} | Output configured as 3.3V & 5.33mA Buffer | — | 1.25 | — | 1.25 | — | 1.25 | — | 1.25 | ns |
| LVCMOS33_8mA_out | t _{BUF} , t _{EN} , t _{DIS} | Output configured as 3.3V & 8mA Buffer | — | 0.40 | — | 0.40 | — | 0.40 | — | 0.40 | ns |
| LVCMOS33_12mA_out | t _{BUF} , t _{EN} , t _{DIS} | Output configured as 3.3V & 12mA Buffer | — | 0.10 | — | 0.10 | — | 0.10 | — | 0.10 | ns |
| LVCMOS33_16mA_out | t _{BUF} , t _{EN} , t _{DIS} | Output configured as 3.3V & 16mA Buffer | — | 0.0 | — | 0.0 | — | 0.0 | — | 0.0 | ns |
| LVCMOS33_20mA_out | t _{BUF} , t _{EN} , t _{DIS} | Output configured as 3.3V & 20mA Buffer | — | 0.0 | — | 0.0 | — | 0.0 | — | 0.0 | ns |
| LVTTTL | t _{BUF} , t _{EN} , t _{DIS} | Output configured as LVTTTL Buffer | — | 0.0 | — | 0.0 | — | 0.0 | — | 0.0 | ns |
| Slow Slew | t _{BUF} , t _{EN} | Output configured for slow slew rate | — | 1.50 | — | 1.50 | — | 1.50 | — | 1.50 | ns |
| PCI_out | t _{BUF} , t _{EN} , t _{DIS} | Using PCI standard | — | 0.0 | — | 0.0 | — | 0.0 | — | 0.0 | ns |
| PCI_X_out | t _{BUF} , t _{EN} , t _{DIS} | Using PCI-X standard | — | 0.0 | — | 0.0 | — | 0.0 | — | 0.0 | ns |
| AGP_1X_out | t _{BUF} , t _{EN} , t _{DIS} | Using AGP-1X standard | — | 0.0 | — | 0.0 | — | 0.0 | — | 0.0 | ns |
| SSTL3_I_out | t _{BUF} , t _{EN} , t _{DIS} | Using SSTL3_I standard | — | -0.25 | — | -0.25 | — | -0.25 | — | -0.25 | ns |
| SSTL3_II_out | t _{BUF} , t _{EN} , t _{DIS} | Using SSTL3_II standard | — | -0.35 | — | -0.35 | — | -0.35 | — | -0.35 | ns |

Note: Open drain timing is the same as corresponding LVCMOS timing.

Timing v.1.10

ispMACH 51024VG Timing Adders (Continued)

| Adder Type | Base Parameter | Description | -5 | | -75 | | -10 | | -12 | | Units |
|--------------|----------------------------------|-------------------------|-----|-------|-----|-------|-----|-------|-----|-------|-------|
| | | | Min | Max | Min | Max | Min | Max | Min | Max | |
| SSTL2_I_out | t_{BUF} , t_{EN} , t_{DIS} | Using SSTL2_I standard | — | 0.0 | — | 0.0 | — | 0.0 | — | 0.0 | ns |
| SSTL2_II_out | t_{BUF} , t_{EN} , t_{DIS} | Using SSTL2_II standard | — | -0.25 | — | -0.25 | — | -0.25 | — | -0.25 | ns |
| CTT33_out | t_{BUF} , t_{EN} , t_{DIS} | Using CCT3.3 standard | — | 0.0 | — | 0.0 | — | 0.0 | — | 0.0 | ns |
| CTT25_out | t_{BUF} , t_{EN} , t_{DIS} | Using CCT2.5 standard | — | 0.25 | — | 0.25 | — | 0.25 | — | 0.25 | ns |
| HSTL_I_out | t_{BUF} , t_{EN} , t_{DIS} | Using HSTL_I standard | — | -0.30 | — | -0.30 | — | -0.30 | — | -0.30 | ns |
| HSTL_III_out | t_{BUF} , t_{EN} , t_{DIS} | Using HSTL_III standard | — | 0.00 | — | 0.00 | — | 0.00 | — | 0.00 | ns |
| GTL+_out | t_{BUF} , t_{EN} , t_{DIS} | Using GTL+ standard | — | 0.30 | — | 0.30 | — | 0.30 | — | 0.30 | ns |

Note: Open drain timing is the same as corresponding LVCMOS timing.

Timing v.1.10

sysCLOCK PLL Timing

Over Recommended Operating Conditions¹

| Symbol | Parameter | Conditions | Min | Max | Units |
|---------------------|--|--|----------|----------|---------------|
| t_R, t_F | Input clock, rise and fall time | 20% to 80% | — | 3.0 | ns |
| t_{INSTB} | Input clock stability, period jitter (peak) ¹ | — | — | +/- 200 | ps |
| t_{PWH} | Input clock, high time | — | 1.6 | — | ns |
| t_{PWL} | Input clock, low time | — | 1.6 | — | ns |
| f_{MDIVIN} | M Divider input, frequency range | — | 5 | 180 | MHz |
| $f_{MDIVOUT}$ | M Divider output, frequency range | — | 5 | 180 | MHz |
| f_{VDIVIN} | V Divider input, frequency range | — | 60 | 200 | MHz |
| $f_{VDIVOUT}$ | V Divider output, frequency range | — | 5 | 180 | MHz |
| $t_{OUTDUTY}$ | Output clock, duty cycle | — | 40 | 60 | % |
| $t_{JIT(CC)}$ | Output clock, cycle to cycle jitter (peak) | Clean Reference, $5\text{MHz} \leq f_{MDIVOUT} < 80\text{MHz}$ | — | +/- 200 | ps |
| | | Clean Reference, $80\text{MHz} \leq f_{MDIVOUT} \leq 180\text{MHz}$ | — | +/- 100 | ps |
| $t_{JIT(\phi)}$ | Output clock, accumulated phase jitter (peak) ² | Clean Reference, $5\text{MHz} \leq f_{MDIVOUT} < 80\text{MHz}$ | — | +/- 200 | ps |
| | | Clean Reference, $80\text{MHz} \leq f_{MDIVOUT} \leq 180\text{MHz}$ | — | +/- 100 | ps |
| $t_{CLK_OUT_DLY}$ | Input clock to CLK_OUT delay | Internal feedback | — | 1 | ns |
| t_ϕ | Input clock to external feedback delta | External feedback | — | 500 | ps |
| t_{LOCK} | Time to acquire phase lock after input stable | — | — | 30 | μs |
| t_{PLL_DELAY} | Delay increment | — | +/- 0.35 | +/- 0.65 | ns |
| t_{RANGE} | Total output delay range | — | +/- 2.45 | +/- 4.55 | ns |
| t_{PLL_RSTR} | Reset recovery time of the M-divider | — | 11.0 | — | ns |
| t_{PLL_RSTW} | Minimum reset pulse width | — | 6.0 | — | ns |

1. This condition assures that the output phase jitter ($t_{JIT(\phi)}$) will remain within specification.

2. Accumulated jitter measured over 10,000 waveform samples.

Boundary Scan Timing Specifications

| Symbol | Parameter | Min. | Max. | Units |
|----------------|--|------|------|-------|
| t_{BTCP} | TCK [BSCAN test] clock cycle | 40 | — | ns |
| t_{BTCH} | TCK [BSCAN test] pulse width high | 20 | — | ns |
| t_{BTCL} | TCK [BSCAN test] pulse width low | 20 | — | ns |
| t_{BTSU} | TCK [BSCAN test] setup time | 8 | — | ns |
| t_{BTH} | TCK [BSCAN test] hold time | 10 | — | ns |
| t_{BRF} | TCK [BSCAN test] rise and fall time | 50 | — | mV/ns |
| t_{BTO} | TAP controller falling edge of clock to valid output | — | 10 | ns |
| t_{BTOZ} | TAP controller falling edge of clock to data output disable | — | 10 | ns |
| t_{BTVO} | TAP controller falling edge of clock to data output enable | — | 10 | ns |
| $t_{BVTCPUSU}$ | BSCAN test Capture register setup time | 8 | — | ns |
| t_{BTCPH} | BSCAN test Capture register hold time | 10 | — | ns |
| t_{BTUCO} | BSCAN test Update reg, falling edge of clock to valid output | — | 25 | ns |
| t_{BTUOZ} | BSCAN test Update reg, falling edge of clock to output disable | — | 25 | ns |
| t_{BTUOV} | BSCAN test Update reg, falling edge of clock to output enable | — | 25 | ns |

Power Consumption

ispMACH 5000VG Typical Power vs. Frequency

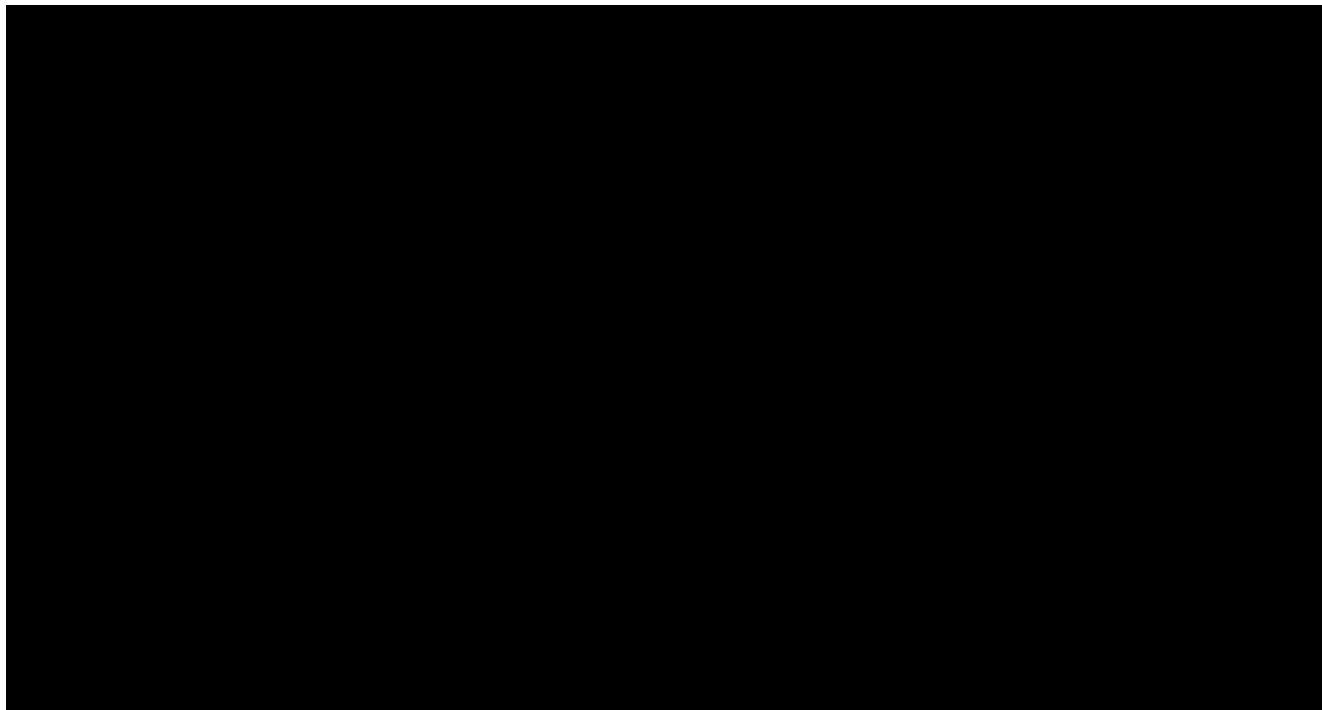

Power Estimation Coefficients

| Device | K0 | K1 | K2 | K3 | K4 | K5 | K6 | I _{DC} (mA) | I _{DCO} (mA) |
|-----------------|--------|--------|-------|-----|-------|-------|-----|----------------------|-----------------------|
| ispMACH 5768VG | 0.0014 | 0.0014 | 0.054 | 1.5 | 0.152 | 0.105 | 5.0 | 65 | 20 |
| ispMACH 51024VG | 0.0014 | 0.0014 | 0.054 | 1.5 | 0.152 | 0.105 | 5.0 | 80 | 20 |

Note: For further information about the use of these coefficients, refer to Technical Note TN1002, *Power Estimation in ispMACH 5000VG Devices*.

- K0 = average current per product term in high power/MHz
- K1 = average current per product term in low power/MHz
- K2 = average current per GRP line/MHz
- K3 = average current per PLL/MHz
- K4 = DC current per product terms in high power
- K5 = DC current per product terms in low power
- K6 = Static DC current per PLL
- I_{DC} = Static device current with all product terms powered off
- I_{DCO} = Static I/O bank current

I_{CC} estimates are based on typical conditions (V_{CC} = 3.3V, room temperature) and an assumption of one GLB load on average exists. These values are for estimates only. Since the value of I_{CC} is sensitive to operating conditions and the program in the device, the actual I_{CC} should be verified.

Switching Test Conditions

Figure 12 shows the output test load that is used for AC testing. The specific values for resistance, capacitance, voltage, and other test conditions are shown in Table 3.

Figure 12. Output Test Load, LVTTTL and LVCMOS Standards

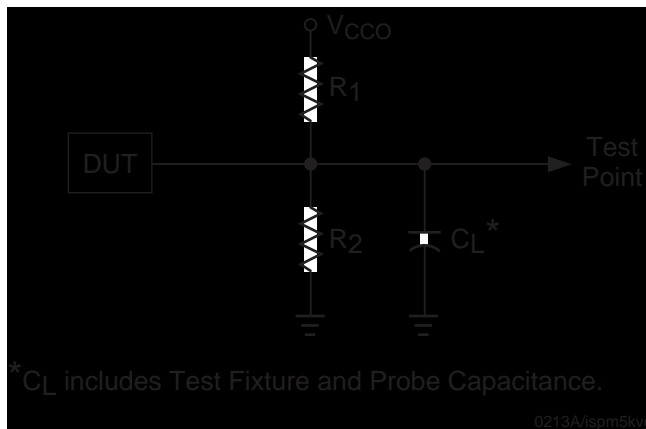

Table 3. Test Fixture Required Components

| Test Condition | R ₁ | R ₂ | C _L | Timing Ref. | V _{CCO} |
|---|----------------|----------------|----------------|----------------------------------|--------------------|
| Default LVCMOS 3.3 I/O (L -> H, H -> L) | 110 | 110 | 35pF | 1.5 | 3.0V |
| Other LVCMOS Settings, (L -> H, H -> L) | ∞ | ∞ | 35pF | LVCMOS 3.3 = 1.5V | LVCMOS 3.3 = 3.0V |
| | | | | LVCMOS 2.5 = V _{CCO} /2 | LVCMOS 2.5 = 2.3V |
| | | | | LVCMOS 1.8 = V _{CCO} /2 | LVCMOS 1.8 = 1.65V |
| Default LVCMOS 3.3 I/O (Z -> H) | ∞ | 110 | 35pF | 1.5V | 3.0V |
| Default LVCMOS 3.3 I/O (Z -> L) | 110 | ∞ | 35pF | 1.5V | 3.0V |
| Default LVCMOS 3.3 I/O (H -> Z) | ∞ | 110 | 5pF | V _{OH} - 0.3 | 3.0V |
| Default LVCMOS 3.3 I/O (L -> Z) | 110 | ∞ | 5pF | V _{OL} + 0.3 | 3.0V |

Output test conditions for all other interfaces are determined by the respective standards. For further details, please refer to the following technical note:

- *ispMACH 5000VG sysIO Design and Usage Guidelines (TN1000)*

Signal Descriptions

| Signal Names | Description |
|---|--|
| TMS | Input - This pin is the Test Mode Select input, which is used to control the 1149.1 state machine. |
| TCK | Input - This pin is the Test Clock input pin, used to clock the 1149.1 state machine. |
| TDI | Input - This pin is the 1149.1 Test Data In pin, used to load data. |
| TDO | Output - This pin is the 1149.1 Test Data Out pin used to shift data out. |
| TOE | Input - Test Output Enable pin. TOE tristates all I/O pins when a logic low is driven. |
| GOE0, GOE1 | Input - These two pins are the Global Output Enable input pins. |
| RESETB | Dedicated Reset Input - This pin resets all registers in the devices. The global polarity (active high or low input) for this pin is selectable. |
| xyzz (e.g. 0A16) | Input/Output - These are the general purpose I/O used by the logic array. x is segment reference (numeric), y is GLB reference (alpha) and z is macrocell reference (numeric). x: 0-7 (1024) x: 0-5 (768) y: A-D z: 0-31 |
| GND | Ground |
| NC | No connect |
| V _{CC} | V _{CC} - These are the power supply pins for the logic core. |
| GCLK0, GCLK3 | Input - These pins are configured to be either dedicated CLK input or PLL input. |
| GCLK1, GCLK2 | Input - These pins are dedicated CLK input. |
| CLK_OUT0, CLK_OUT1 | Output - These pins are the PLL output pins. |
| PLL_RST0, PLL_RST1 | Input - These pins are for resetting the PLL, input clock (M) divider. |
| VREF0, VREF1, VREF2, VREF3 | Input - These are the reference supplies for the I/O banks. |
| PLL_FBK0, PLL_FBK1 | Input - These PLL feedback inputs allow optional external PLL feedback. |
| V _{CCP0} , V _{CCP1} | V _{CC} - These are the V _{CC} supplies for the PLLs. |
| V _{CCO0} , V _{CCO1} , V _{CCO2} , V _{CCO3} | V _{CC} - These are the V _{CC} supplies for each I/O bank. |
| GNDP0, GNDP1 | GND - These are the separate ground connections for the PLLs. |
| V _{CCJ} | V _{CC} - This pin is for the 1149.1 test access port. |

Note: For above, signal CLK_OUT0 connects to PLL0, and signal CLK_OUT1 connects to PLL1.

ispMACH 5768VG Power Supply and NC Connections¹

| Signal | 256-Ball fpBGA ² | 484-Ball fpBGA ² |
|-------------------|---|---|
| V _{CC} | F8, F9, H6, H11, J6, J11, L8, L9 | B17, B2, B21, B6, C14, C9, E18, E5, F2, F21, J20, J3, P20, P3, U2, U21, Y14, Y9, AA17, AA2, AA21, AA6 |
| V _{CCO0} | C3, C7, G3 | B5, D7, E2, E6, E9, F5, G4, J5 |
| V _{CCO1} | K3, P3, P7 | P5, U5, V6, V9, Y3 |
| V _{CCO2} | K14, P10, P14 | P18, U18, V14, V17, Y20 |
| V _{CCO3} | C10, C14, G14 | B18, D16, E14, E17, E21, F18, G19, J18 |
| V _{CCP0} | H1 | L7 |
| V _{CCP1} | H16 | N18 |
| V _{CCJ} | J1 | P4 |
| V _{REF0} | E7 | A9 |
| V _{REF1} | M7 | AA10 |
| V _{REF2} | R13 | AA13 |
| V _{REF3} | A8 | A15 |
| GND PLL 0 | H7 | L6 |
| GND PLL 1 | J10 | L16 |
| GND | A1, C5, C12, E3, E14, G7, G8, G9, G10, H8, H9, H10, J7, J8, J9, K7, K8, K9, K10, M3, M14, P5, P12 | A1, A22, C3, C20, D4, D19, E7, E16, G5, G7, G8, G9, G10, G11, G12, G13, G14, G15, G16, G18, H7, H8, H9, H10, H11, H12, H13, H14, H15, H16, J7, J8, J9, J10, J11, J12, J13, J14, J15, J16, K7, K8, K9, K10, K11, K12, K13, K14, K15, K16, L8, L9, L10, L11, L12, L13, L14, L15, M7, M8, M9, M10, M11, M12, M13, M14, M15, M16, N7, N8, N9, N10, N11, N12, N13, N14, N15, N16, P7, P8, P9, P10, P11, P12, P13, P14, P15, P16, R7, R8, R9, R10, R11, R12, R13, R14, R15, R16, T4, T7, T8, T9, T10, T11, T12, T13, T14, T15, T16, T19, W7, W16, AB1, AB22 |
| NC ³ | — | AA1 |

1. All grounds must be electrically connected at the board level.
2. Not all grounds internally connected within the device.
3. NC pins are not to be connected to any active signals, VCC or GND.

ispMACH 51024 Power Supply and NC Connections¹

| Signal | 484-Ball fpBGA ² | 676-Ball fpBGA ² |
|-------------------|---|--|
| V _{CC} | B17, B2, B21, B6, C14, C9, E18, E5, F2, F21, J20, J3, P20, P3, U2, U21, Y14, Y9, AA17, AA2, AA21, AA6 | B29, D6, D10, D12, D19, D21, D25, F4, F27, K4, K27, M4, M27, W4, W27, AA4, AA27, AE4, AE27, AG6, AG10, AG12, AG19, AG21, AG25, AJ2 |
| V _{CCO0} | B5, D7, E2, E6, E9, F5, G4, J5 | E5, E7, E9, E11, F10, G5, J5, K6, L5 |
| V _{CCO1} | P5, U5, V6, V9, Y3 | Y5, AA6, AB5, AD5, AE10, AF5, AF7, AF9, AF11 |
| V _{CCO2} | P18, U18, V14, V17, Y20 | Y26, AA25, AB26, AD26, AE21, AF20, AF22, AF24, AF26 |
| V _{CCO3} | B18, D16, E14, E17, E21, F18, G19, J18 | E20, E22, E24, E26, F21, G26, J26, K25, L26 |
| V _{CCP0} | L7 | P5 |
| V _{CCP1} | N18 | N26 |
| V _{CCJ} | P4 | U6 |
| V _{REF0} | A9 | C11 |
| V _{REF1} | AA10 | AK10 |
| V _{REF2} | AA13 | AJ21 |
| V _{REF3} | A15 | E19 |
| GND PLL 0 | L6 | R6 |
| GND PLL 1 | L16 | P25 |
| GND | A1, A22, C3, C20, D4, D19, E7, E16, G5, G7, G8, G9, G10, G11, G12, G13, G14, G15, G16, G18, H7, H8, H9, H10, H11, H12, H13, H14, H15, H16, J7, J8, J9, J10, J11, J12, J13, J14, J15, J16, K7, K8, K9, K10, K11, K12, K13, K14, K15, K16, L8, L9, L10, L11, L12, L13, L14, L15, M7, M8, M9, M10, M11, M12, M13, M14, M15, M16, N7, N8, N9, N10, N11, N12, N13, N14, N15, N16, P7, P8, P9, P10, P11, P12, P13, P14, P15, P16, R7, R8, R9, R10, R11, R12, R13, R14, R15, R16, T4, T7, T8, T9, T10, T11, T12, T13, T14, T15, T16, T19, W7, W16, AB1, AB22 | A1, A30, B2, C3, C28, D8, D23, F7, F9, F11, F12, F19, F20, F22, F24, G6, G25, H4, H27, J6, J25, L6, L11, L12, L13, L14, L15, L16, L17, L18, L19, L20, L25, M6, M11, M12, M13, M14, M15, M16, M17, M18, M19, M20, M25, N11, N12, N13, N14, N15, N16, N17, N18, N19, N20, P11, P12, P13, P14, P15, P16, P17, P18, P19, P20, R11, R12, R13, R14, R15, R16, R17, R18, R19, R20, T11, T12, T13, T14, T15, T16, T17, T18, T19, T20, U11, U12, U13, U14, U15, U16, U17, U18, U19, U20, V11, V12, V13, V14, V15, V16, V17, V18, V19, V20, W6, W11, W12, W13, W14, W15, W16, W17, W18, W19, W20, W25, Y6, Y11, Y12, Y13, Y14, Y15, Y16, Y17, Y18, Y19, Y20, Y25, AB6, AB25, AC4, AC27, AD6, AD25, AE7, AE9, AE11, AE12, AE19, AE20, AE22, AE24, AG8, AG23, AH3, AH28, AK1, AK30 |
| NC ³ | AA1 | A14, A15, A16, A17, B14, B15, B16, B17, C13, C14, C15, C16, C17, C18, D13, D14, D15, D16, D17, D18, E13, E14, E15, E16, E17, E18, F13, F14, F15, F16, F17, F18, AE13, AE14, AE15, AE16, AE17, AE18, AF13, AF14, AF15, AF16, AF17, AF18, AG13, AG14, AG15, AG16, AG17, AG18, AH14, AH15, AH16, AH17, AH18, AJ14, AJ15, AJ16, AJ17, AJ18, AK14, AK15, AK16, AK17 |

1. All grounds must be electrically connected at the board level.
2. Not all grounds internally connected within the device.
3. NC pins are not to be connected to any active signals, VCC or GND.

ispMACH 5768VG Logic Signal Connections

| Bank No. | Signal | 256 fpBGA | 484 fpBGA |
|----------|-------------|-----------|-----------|
| 0 | 0C-30 | C8 | D11 |
| 0 | 0C-28 | B6 | B11 |
| 0 | 0C-26 | A5 | E12 |
| 0 | 0C-24 | D8 | C11 |
| 0 | 0C-22 | E8 | F12 |
| 0 | 0C-20 | B5 | B10 |
| 0 | GNDIO0 | GND | GND |
| 0 | 0C-18 | A4 | A10 |
| 0 | 0C-16 | D7 | D10 |
| 0 | 0C-14/VREF0 | E7 | A9 |
| 0 | 0C-12 | C6 | E11 |
| 0 | 0C-10 | B4 | B9 |
| 0 | 0C-8 | A3 | F11 |
| 0 | 0C-6 | NC | A8 |
| 0 | 0C-4 | NC | C10 |
| 0 | 0C-2 | NC | A7 |
| 0 | 0C-0 | NC | E10 |
| 0 | 0D-30 | NC | B8 |
| 0 | 0D-28 | NC | C8 |
| 0 | GNDIO0 | GND | GND |
| 0 | 0D-26 | NC | F10 |
| 0 | 0D-24 | NC | A6 |
| 0 | 0D-22 | NC | F9 |
| 0 | 0D-20 | NC | C7 |
| 0 | 0D-18 | NC | D9 |
| 0 | 0D-16 | NC | B7 |
| 0 | 0D-14 | D6 | E8 |
| 0 | 0D-12 | E6 | A5 |
| 0 | 0D-10 | A2 | F8 |
| 0 | 0D-8 | B3 | C6 |
| 0 | 0D-6 | C4 | D8 |
| 0 | 0D-4 | D5 | A3 |
| 0 | GNDIO0 | GND | GND |
| 0 | 0D-2 | NC | A2 |
| 0 | 0D-0 | NC | A4 |
| 0 | 0A-0 | NC | F7 |
| 0 | 0A-2 | NC | C5 |
| 0 | 0A-4 | NC | F6 |
| 0 | 0A-6 | NC | B3 |
| 0 | 0A-8 | NC | NC |
| 0 | 0A-10 | NC | NC |
| 0 | GNDIO0 | GND | GND |
| 0 | 0A-12 | NC | NC |

| Bank No. | Signal | 256 fpBGA | 484 fpBGA |
|----------|--------|-----------|-----------|
| 0 | 0A-14 | NC | NC |
| 0 | 0A-16 | NC | B4 |
| 0 | 0A-18 | NC | D5 |
| 0 | 0A-20 | NC | B1 |
| 0 | 0A-22 | NC | D6 |
| 0 | 0A-24 | NC | C4 |
| 0 | 0A-26 | NC | E4 |
| 0 | GNDIO0 | GND | GND |
| 0 | 0A-28 | B2 | C2 |
| 0 | 0A-30 | B1 | C1 |
| 0 | 0B-30 | C2 | D1 |
| 0 | 0B-28 | C1 | D2 |
| 0 | 0B-26 | NC | D3 |
| 0 | 0B-24 | NC | E1 |
| 0 | 0B-22 | NC | E3 |
| 0 | 0B-20 | NC | F4 |
| 0 | 0B-18 | NC | F1 |
| 0 | 0B-16 | NC | F3 |
| 0 | 0B-14 | NC | G6 |
| 0 | 0B-12 | NC | G1 |
| 0 | GNDIO0 | GND | GND |
| 0 | 0B-10 | NC | G2 |
| 0 | 0B-8 | NC | H1 |
| 0 | 0B-6 | NC | G3 |
| 0 | 0B-4 | NC | H2 |
| 0 | 0B-2 | NC | H5 |
| 0 | 0B-0 | NC | H6 |
| 0 | 1A-0 | F7 | J1 |
| 0 | 1A-2 | F6 | K1 |
| 0 | 1A-4 | E5 | H3 |
| 0 | 1A-6 | D4 | J2 |
| 0 | 1A-8 | D3 | H4 |
| 0 | 1A-10 | D2 | K2 |
| 0 | GNDIO0 | GND | GND |
| 0 | 1A-12 | D1 | J6 |
| 0 | 1A-14 | E4 | L1 |
| 0 | 1A-16 | NC | K3 |
| 0 | 1A-18 | NC | J4 |
| 0 | 1A-20 | NC | L2 |
| 0 | 1A-22 | NC | M1 |
| 0 | 1A-24 | NC | K6 |
| 0 | 1A-26 | NC | K4 |
| 0 | 1A-28 | NC | L3 |

ispMACH 5768VG Logic Signal Connections (Continued)

| Bank No. | Signal | 256 fpBGA | 484 fpBGA |
|----------|----------------|-----------|-----------|
| 0 | 1A-30 | NC | K5 |
| 0 | GNDIO0 | GND | GND |
| 0 | 1B-30/CLK_OUT0 | G6 | N1 |
| 0 | 1B-28 | NC | M2 |
| 0 | 1B-26 | NC | P1 |
| 0 | 1B-24 | NC | L4 |
| 0 | 1B-22 | F5 | N2 |
| 0 | 1B-20 | E2 | M3 |
| 0 | 1B-18 | E1 | L5 |
| 0 | 1B-16 | F4 | R1 |
| 0 | 1B-14 | F3 | P2 |
| 0 | 1B-12 | F2 | N3 |
| 0 | GNDIO0 | GND | GND |
| 0 | 1B-10 | G5 | M6 |
| 0 | 1B-8 | G4 | M5 |
| 0 | 1B-6/PLL_RST0 | F1 | M4 |
| 0 | 1B-4/PLL_FBK0 | G2 | N4 |
| 0 | 1B-2 | G1 | N6 |
| 0 | 1B-0 | H5 | N5 |
| 1 | 2B-0 | K1 | R5 |
| 1 | 2B-2 | K2 | T2 |
| 1 | 2B-4 | L1 | T5 |
| 1 | 2B-6 | J5 | T3 |
| 1 | 2B-8 | L2 | U1 |
| 1 | 2B-10 | K4 | U4 |
| 1 | GNDIO1 | GND | GND |
| 1 | 2B-12 | M1 | V1 |
| 1 | 2B-14 | L3 | U3 |
| 1 | 2B-16 | L4 | V5 |
| 1 | 2B-18 | K5 | V2 |
| 1 | 2B-20 | M2 | W1 |
| 1 | 2B-22 | N1 | V3 |
| 1 | 2B-24 | NC | W2 |
| 1 | 2B-26 | K6 | Y1 |
| 1 | 2B-28 | L5 | Y2 |
| 1 | 2B-30 | N2 | W3 |
| 1 | 2A-30 | L6 | AA3 |
| 1 | 2A-28 | L7 | W4 |
| 1 | GNDIO1 | GND | GND |
| 1 | 2A-26 | P1 | W5 |
| 1 | 2A-24 | P2 | Y4 |
| 1 | 2A-22 | N3 | T6 |
| 1 | 2A-20 | R4 | Y5 |

| Bank No. | Signal | 256 fpBGA | 484 fpBGA |
|----------|-------------|-----------|-----------|
| 1 | 2A-18 | NC | U6 |
| 1 | 2A-16 | R1 | AA4 |
| 1 | 2A-14 | NC | NC |
| 1 | 2A-12 | NC | NC |
| 1 | GNDIO1 | GND | GND |
| 1 | 2A-10 | NC | NC |
| 1 | 2A-8 | NC | NC |
| 1 | 2A-6 | T1 | W6 |
| 1 | 2A-4 | T2 | V4 |
| 1 | 2A-2 | R2 | U7 |
| 1 | 2A-0 | T3 | AB2 |
| 1 | 2D-0 | R3 | V7 |
| 1 | 2D-2 | P4 | AA5 |
| 1 | GNDIO1 | GND | GND |
| 1 | 2D-4 | T4 | AB3 |
| 1 | 2D-6 | N4 | Y6 |
| 1 | 2D-8 | M4 | AB4 |
| 1 | 2D-10 | N5 | Y7 |
| 1 | 2D-12 | R5 | AB5 |
| 1 | 2D-14 | T5 | V8 |
| 1 | 2D-16 | NC | AA7 |
| 1 | 2D-18 | NC | Y8 |
| 1 | 2D-20 | NC | AB6 |
| 1 | 2D-22 | T6 | W8 |
| 1 | 2D-24 | R6 | AA8 |
| 1 | 2D-26 | P6 | Y10 |
| 1 | GNDIO1 | GND | GND |
| 1 | 2D-28 | M5 | U8 |
| 1 | 2D-30 | T7 | AB7 |
| 1 | 2C-0 | T8 | U9 |
| 1 | 2C-2 | R8 | AA9 |
| 1 | 2C-4 | M6 | W9 |
| 1 | 2C-6 | N6 | AB8 |
| 1 | 2C-8 | R7 | U10 |
| 1 | 2C-10 | T9 | AB9 |
| 1 | 2C-12 | T10 | V11 |
| 1 | 2C-14/VREF1 | M7 | AA10 |
| 1 | 2C-16 | N7 | V10 |
| 1 | 2C-18 | P8 | AB10 |
| 1 | GNDIO1 | GND | GND |
| 1 | 2C-20 | R9 | W10 |
| 1 | 2C-22 | N8 | W11 |
| 1 | 2C-24 | M8 | U11 |

ispMACH 5768VG Logic Signal Connections (Continued)

| Bank No. | Signal | 256 fpBGA | 484 fpBGA |
|----------|-------------|-----------|-----------|
| 1 | 2C-26 | T11 | AA11 |
| 1 | 2C-28 | T12 | V12 |
| 1 | 2C-30 | R10 | AB11 |
| 2 | 3C-30 | P9 | W12 |
| 2 | 3C-28 | R11 | Y11 |
| 2 | 3C-26 | T13 | Y12 |
| 2 | 3C-24 | N9 | AB12 |
| 2 | 3C-22 | M9 | U12 |
| 2 | 3C-20 | R12 | AA12 |
| 2 | GNDIO2 | GND | GND |
| 2 | 3C-18 | P11 | Y13 |
| 2 | 3C-16 | N10 | AB13 |
| 2 | 3C-14 | M10 | W13 |
| 2 | 3C-12/VREF2 | R13 | AA13 |
| 2 | 3C-10 | T14 | U13 |
| 2 | 3C-8 | R14 | AB14 |
| 2 | 3C-6 | M11 | V13 |
| 2 | 3C-4 | N11 | AA14 |
| 2 | 3C-2 | P13 | U14 |
| 2 | 3C-0 | T15 | AB15 |
| 2 | 3D-30 | T16 | Y15 |
| 2 | 3D-28 | N12 | AB16 |
| 2 | GNDIO2 | GND | GND |
| 2 | 3D-26 | NC | AA15 |
| 2 | 3D-24 | NC | W14 |
| 2 | 3D-22 | NC | AB17 |
| 2 | 3D-20 | NC | Y16 |
| 2 | 3D-18 | NC | AA16 |
| 2 | 3D-16 | NC | Y17 |
| 2 | 3D-14 | NC | AB18 |
| 2 | 3D-12 | NC | V15 |
| 2 | 3D-10 | NC | AB19 |
| 2 | 3D-8 | NC | W15 |
| 2 | 3D-6 | NC | AB20 |
| 2 | 3D-4 | NC | AA18 |
| 2 | GNDIO2 | GND | GND |
| 2 | 3D-2 | L10 | U15 |
| 2 | 3D-0 | L11 | W17 |
| 2 | 3A-0 | K11 | U16 |
| 2 | 3A-2 | R15 | AA19 |
| 2 | 3A-4 | NC | V16 |
| 2 | 3A-6 | NC | AB21 |
| 2 | 3A-8 | NC | NC |

| Bank No. | Signal | 256 fpBGA | 484 fpBGA |
|----------|---------------|-----------|-----------|
| 2 | 3A-10 | NC | NC |
| 2 | GNDIO2 | GND | GND |
| 2 | 3A-12 | NC | NC |
| 2 | 3A-14 | NC | NC |
| 2 | 3A-16 | NC | Y18 |
| 2 | 3A-18 | P15 | W18 |
| 2 | 3A-20 | R16 | AA20 |
| 2 | 3A-22 | P16 | W19 |
| 2 | 3A-24 | N14 | Y19 |
| 2 | 3A-26 | N13 | V19 |
| 2 | GNDIO2 | GND | GND |
| 2 | 3A-28 | N15 | Y21 |
| 2 | 3A-30 | N16 | W20 |
| 2 | 3B-30 | M16 | AA22 |
| 2 | 3B-28 | M12 | W21 |
| 2 | 3B-26 | NC | Y22 |
| 2 | 3B-24 | NC | V20 |
| 2 | 3B-22 | M13 | V21 |
| 2 | 3B-20 | M15 | W22 |
| 2 | 3B-18 | L16 | V18 |
| 2 | 3B-16 | L15 | U20 |
| 2 | 3B-14 | L13 | V22 |
| 2 | 3B-12 | L14 | U19 |
| 2 | GNDIO2 | GND | GND |
| 2 | 3B-10 | L12 | U17 |
| 2 | 3B-8 | K13 | U22 |
| 2 | 3B-6 | K15 | T20 |
| 2 | 3B-4 | K16 | T21 |
| 2 | 3B-2 | J16 | T17 |
| 2 | 3B-0 | K12 | R20 |
| 3 | 4B-0 | J12 | R21 |
| 3 | 4B-2 | G16 | T22 |
| 3 | 4B-4/PLL_FBK1 | G15 | P21 |
| 3 | 4B-6/PLL_RST1 | H12 | N20 |
| 3 | 4B-8 | G12 | R22 |
| 3 | 4B-10 | G13 | N21 |
| 3 | GNDIO3 | GND | GND |
| 3 | 4B-12 | F16 | M18 |
| 3 | 4B-14 | F15 | N19 |
| 3 | 4B-16 | F13 | P22 |
| 3 | 4B-18 | F14 | M20 |
| 3 | 4B-20 | F12 | N22 |
| 3 | 4B-22 | E16 | N17 |

ispMACH 5768VG Logic Signal Connections (Continued)

| Bank No. | Signal | 256 fpBGA | 484 fpBGA |
|----------|----------------|-----------|-----------|
| 3 | 4B-24 | G11 | M19 |
| 3 | 4B-26 | F11 | M21 |
| 3 | 4B-28 | F10 | L19 |
| 3 | 4B-30/CLK_OUT1 | B11 | L20 |
| 3 | GNDIO3 | GND | GND |
| 3 | 4A-30 | NC | M17 |
| 3 | 4A-28 | NC | M22 |
| 3 | 4A-26 | NC | K20 |
| 3 | 4A-24 | NC | L18 |
| 3 | 4A-22 | NC | L21 |
| 3 | 4A-20 | NC | K19 |
| 3 | 4A-18 | NC | L22 |
| 3 | 4A-16 | NC | K17 |
| 3 | 4A-14 | E13 | K22 |
| 3 | 4A-12 | B12 | L17 |
| 3 | GNDIO3 | GND | GND |
| 3 | 4A-10 | E15 | K21 |
| 3 | 4A-8 | D15 | K18 |
| 3 | 4A-6 | NC | J17 |
| 3 | 4A-4 | NC | J19 |
| 3 | 4A-2 | D16 | J22 |
| 3 | 4A-0 | E12 | J21 |
| 3 | 5B-0 | NC | H19 |
| 3 | 5B-2 | NC | H20 |
| 3 | 5B-4 | NC | H17 |
| 3 | 5B-6 | NC | H18 |
| 3 | 5B-8 | NC | H22 |
| 3 | 5B-10 | NC | H21 |
| 3 | GNDIO3 | GND | GND |
| 3 | 5B-12 | NC | G20 |
| 3 | 5B-14 | NC | G22 |
| 3 | 5B-16 | NC | G17 |
| 3 | 5B-18 | NC | G21 |
| 3 | 5B-20 | NC | F19 |
| 3 | 5B-22 | NC | F20 |
| 3 | 5B-24 | A16 | F22 |
| 3 | 5B-26 | B15 | E22 |
| 3 | 5B-28 | A15 | E19 |
| 3 | 5B-30 | D13 | E20 |
| 3 | 5A-30 | B14 | D22 |
| 3 | 5A-28 | B16 | D21 |
| 3 | GNDIO3 | GND | GND |
| 3 | 5A-26 | C16 | D20 |

| Bank No. | Signal | 256 fpBGA | 484 fpBGA |
|----------|-------------|-----------|-----------|
| 3 | 5A-24 | C15 | C22 |
| 3 | 5A-22 | D14 | C18 |
| 3 | 5A-20 | A14 | C19 |
| 3 | 5A-18 | C13 | D17 |
| 3 | 5A-16 | B13 | C21 |
| 3 | 5A-14 | NC | NC |
| 3 | 5A-12 | NC | NC |
| 3 | GNDIO3 | GND | GND |
| 3 | 5A-10 | NC | NC |
| 3 | 5A-8 | NC | NC |
| 3 | 5A-6 | NC | B22 |
| 3 | 5A-4 | NC | D18 |
| 3 | 5A-2 | NC | B20 |
| 3 | 5A-0 | NC | F17 |
| 3 | 5D-0 | NC | B19 |
| 3 | 5D-2 | NC | C17 |
| 3 | GNDIO3 | GND | GND |
| 3 | 5D-4 | NC | A21 |
| 3 | 5D-6 | NC | D15 |
| 3 | 5D-8 | NC | A20 |
| 3 | 5D-10 | NC | C16 |
| 3 | 5D-12 | NC | A19 |
| 3 | 5D-14 | NC | F16 |
| 3 | 5D-16 | NC | B16 |
| 3 | 5D-18 | NC | D14 |
| 3 | 5D-20 | NC | A18 |
| 3 | 5D-22 | A13 | F15 |
| 3 | 5D-24 | A12 | A17 |
| 3 | 5D-26 | A11 | B15 |
| 3 | GNDIO3 | GND | GND |
| 3 | 5D-28 | A10 | A16 |
| 3 | 5D-30 | C11 | F14 |
| 3 | 5C-0 | A9 | C15 |
| 3 | 5C-2 | D12 | D13 |
| 3 | 5C-4 | D11 | E15 |
| 3 | 5C-6 | B10 | F13 |
| 3 | 5C-8 | B9 | B14 |
| 3 | 5C-10 | E11 | E13 |
| 3 | 5C-12/VREF3 | A8 | A15 |
| 3 | 5C-14 | D10 | D12 |
| 3 | 5C-16 | E10 | A14 |
| 3 | 5C-18 | A7 | B13 |
| 3 | GNDIO3 | GND | GND |

ispMACH 5768VG Logic Signal Connections (Continued)

| Bank No. | Signal | 256 fpBGA | 484 fpBGA |
|-----------------|---------------|------------------|------------------|
| 3 | 5C-20 | C9 | A13 |
| 3 | 5C-22 | E9 | B12 |
| 3 | 5C-24 | D9 | C13 |
| 3 | 5C-26 | B8 | A12 |
| 3 | 5C-28 | A6 | C12 |
| 3 | 5C-30 | B7 | A11 |
| — | GCLK0 | H4 | P6 |
| — | GCLK1 | J4 | R6 |
| — | GCLK2 | H14 | P17 |
| — | GCLK3 | H13 | P19 |
| — | GOE0 | J15 | R18 |
| — | GOE1 | H15 | R17 |
| — | RESETB | J14 | R19 |
| — | TCK | J3 | R3 |
| — | TDI | H3 | R2 |
| — | TDO | J2 | R4 |
| — | TMS | H2 | T1 |
| — | TOE | J13 | T18 |

ispMACH 51024VG Logic Signal Connections

| Bank No. | Signal | 484 fpBGA | 676 fpBGA |
|----------|-------------|-----------|-----------|
| 0 | 0C-30 | D11 | A13 |
| 0 | 0C-28 | B11 | B13 |
| 0 | 0C-26 | E12 | A12 |
| 0 | 0C-24 | C11 | B12 |
| 0 | 0C-22 | F12 | C12 |
| 0 | 0C-20 | B10 | A11 |
| 0 | GNDIO0 | GND | GND |
| 0 | 0C-18 | A10 | B11 |
| 0 | 0C-16 | D10 | A10 |
| 0 | 0C-14/VREF0 | A9 | C11 |
| 0 | 0C-12 | E11 | E12 |
| 0 | 0C-10 | B9 | B10 |
| 0 | 0C-8 | F11 | D11 |
| 0 | 0C-6 | A8 | A9 |
| 0 | 0C-4 | C10 | C10 |
| 0 | 0C-2 | A7 | B9 |
| 0 | 0C-0 | E10 | A8 |
| 0 | 0D-30 | B8 | C9 |
| 0 | 0D-28 | C8 | B8 |
| 0 | GNDIO0 | GND | GND |
| 0 | 0D-26 | F10 | E10 |
| 0 | 0D-24 | A6 | A7 |
| 0 | 0D-22 | F9 | D9 |
| 0 | 0D-20 | C7 | C8 |
| 0 | 0D-18 | D9 | B7 |
| 0 | 0D-16 | B7 | A6 |
| 0 | 0D-14 | E8 | C7 |
| 0 | 0D-12 | A5 | B6 |
| 0 | 0D-10 | F8 | A5 |
| 0 | 0D-8 | C6 | C6 |
| 0 | 0D-6 | D8 | D7 |
| 0 | 0D-4 | A3 | E8 |
| 0 | GNDIO0 | GND | GND |
| 0 | 0D-2 | A2 | B5 |
| 0 | 0D-0 | A4 | A4 |
| 0 | 0A-0 | F7 | A3 |
| 0 | 0A-2 | C5 | B4 |
| 0 | 0A-4 | F6 | C5 |
| 0 | 0A-6 | B3 | F8 |
| 0 | 0A-8 | NC | A2 |
| 0 | 0A-10 | NC | B3 |
| 0 | GNDIO0 | GND | GND |
| 0 | 0A-12 | NC | C4 |

| Bank No. | Signal | 484 fpBGA | 676 fpBGA |
|----------|--------|-----------|-----------|
| 0 | 0A-14 | NC | D5 |
| 0 | 0A-16 | B4 | E6 |
| 0 | 0A-18 | D5 | D4 |
| 0 | 0A-20 | B1 | B1 |
| 0 | 0A-22 | D6 | C2 |
| 0 | 0A-24 | C4 | F6 |
| 0 | 0A-26 | E4 | D3 |
| 0 | GNDIO0 | GND | GND |
| 0 | 0A-28 | C2 | E4 |
| 0 | 0A-30 | C1 | F5 |
| 0 | 0B-30 | D1 | C1 |
| 0 | 0B-28 | D2 | D2 |
| 0 | 0B-26 | D3 | E3 |
| 0 | 0B-24 | E1 | D1 |
| 0 | 0B-22 | E3 | E2 |
| 0 | 0B-20 | F4 | H6 |
| 0 | 0B-18 | F1 | F3 |
| 0 | 0B-16 | F3 | E1 |
| 0 | 0B-14 | G6 | G4 |
| 0 | 0B-12 | G1 | F2 |
| 0 | GNDIO0 | GND | GND |
| 0 | 0B-10 | G2 | H5 |
| 0 | 0B-8 | H1 | G3 |
| 0 | 0B-6 | G3 | F1 |
| 0 | 0B-4 | H2 | G2 |
| 0 | 0B-2 | H5 | H3 |
| 0 | 0B-0 | H6 | G1 |
| 0 | 1A-0 | J1 | H2 |
| 0 | 1A-2 | K1 | J4 |
| 0 | 1A-4 | H3 | H1 |
| 0 | 1A-6 | J2 | J3 |
| 0 | 1A-8 | H4 | K5 |
| 0 | 1A-10 | K2 | J2 |
| 0 | GNDIO0 | GND | GND |
| 0 | 1A-12 | J6 | J1 |
| 0 | 1A-14 | L1 | K3 |
| 0 | 1A-16 | K3 | K2 |
| 0 | 1A-18 | J4 | K1 |
| 0 | 1A-20 | L2 | L4 |
| 0 | 1A-22 | M1 | L3 |
| 0 | 1A-24 | K6 | L2 |
| 0 | 1A-26 | K4 | M5 |
| 0 | 1A-28 | L3 | L1 |

ispMACH 51024VG Logic Signal Connections (Continued)

| Bank No. | Signal | 484 fpBGA | 676 fpBGA |
|----------|----------------|-----------|-----------|
| 0 | 1A-30 | K5 | M3 |
| 0 | GNDIO0 | GND | GND |
| 0 | 1B-30/CLK_OUT0 | N1 | M2 |
| 0 | 1B-28 | M2 | M1 |
| 0 | 1B-26 | P1 | N6 |
| 0 | 1B-24 | L4 | N5 |
| 0 | 1B-22 | N2 | N4 |
| 0 | 1B-20 | M3 | N3 |
| 0 | 1B-18 | L5 | N2 |
| 0 | 1B-16 | R1 | N1 |
| 0 | 1B-14 | P2 | P6 |
| 0 | 1B-12 | N3 | P4 |
| 0 | GNDIO0 | GND | GND |
| 0 | 1B-10 | M6 | P3 |
| 0 | 1B-8 | M5 | P2 |
| 0 | 1B-6/PLL_RST0 | M4 | P1 |
| 0 | 1B-4/PLL_FBK0 | N4 | R4 |
| 0 | 1B-2 | N6 | R3 |
| 0 | 1B-0 | N5 | R2 |
| 1 | 2B-0 | NC | R1 |
| 1 | 2B-2 | NC | T1 |
| 1 | 2B-4 | NC | T3 |
| 1 | 2B-6 | NC | T2 |
| 1 | 2B-8 | NC | U1 |
| 1 | 2B-10 | NC | U2 |
| 1 | GNDIO1 | GND | GND |
| 1 | 2B-12 | NC | U3 |
| 1 | 2B-14 | NC | U4 |
| 1 | 2B-16 | NC | V1 |
| 1 | 2B-18 | NC | V2 |
| 1 | 2B-20 | NC | V3 |
| 1 | 2B-22 | NC | V4 |
| 1 | 2B-24 | NC | W1 |
| 1 | 2B-26 | NC | V6 |
| 1 | 2B-28 | NC | W2 |
| 1 | 2B-30 | NC | W3 |
| 1 | GNDIO1 | GND | GND |
| 1 | 2A-30 | NC | Y1 |
| 1 | 2A-28 | NC | W5 |
| 1 | 2A-26 | NC | Y2 |
| 1 | 2A-24 | NC | Y3 |
| 1 | 2A-22 | NC | AA1 |
| 1 | 2A-20 | NC | Y4 |

| Bank No. | Signal | 484 fpBGA | 676 fpBGA |
|----------|--------|-----------|-----------|
| 1 | 2A-18 | NC | AA2 |
| 1 | 2A-16 | NC | AA3 |
| 1 | 2A-14 | NC | AB1 |
| 1 | 2A-12 | NC | AB2 |
| 1 | GNDIO1 | GND | GND |
| 1 | 2A-10 | NC | AA5 |
| 1 | 2A-8 | NC | AB3 |
| 1 | 2A-6 | NC | AC1 |
| 1 | 2A-4 | NC | AB4 |
| 1 | 2A-2 | NC | AC2 |
| 1 | 2A-0 | NC | AD1 |
| 1 | 3B-0 | R5 | AC3 |
| 1 | 3B-2 | T2 | AD2 |
| 1 | 3B-4 | T5 | AE1 |
| 1 | 3B-6 | T3 | AD3 |
| 1 | 3B-8 | U1 | AE2 |
| 1 | 3B-10 | U4 | AC5 |
| 1 | GNDIO1 | GND | GND |
| 1 | 3B-12 | V1 | AF1 |
| 1 | 3B-14 | U3 | AD4 |
| 1 | 3B-16 | V5 | AE3 |
| 1 | 3B-18 | V2 | AC6 |
| 1 | 3B-20 | W1 | AF2 |
| 1 | 3B-22 | V3 | AG1 |
| 1 | 3B-24 | W2 | AF3 |
| 1 | 3B-26 | Y1 | AG2 |
| 1 | 3B-28 | Y2 | AH1 |
| 1 | 3B-30 | W3 | AE5 |
| 1 | 3A-30 | AA3 | AF4 |
| 1 | 3A-28 | W4 | AG3 |
| 1 | GNDIO1 | GND | GND |
| 1 | 3A-26 | W5 | AE6 |
| 1 | 3A-24 | Y4 | AH2 |
| 1 | 3A-22 | T6 | AJ1 |
| 1 | 3A-20 | Y5 | AG4 |
| 1 | 3A-18 | U6 | AF6 |
| 1 | 3A-16 | AA4 | AG5 |
| 1 | 3A-14 | NC | AH4 |
| 1 | 3A-12 | NC | AJ3 |
| 1 | GNDIO1 | GND | GND |
| 1 | 3A-10 | NC | AK2 |
| 1 | 3A-8 | NC | AE8 |
| 1 | 3A-6 | W6 | AH5 |

ispMACH 51024VG Logic Signal Connections (Continued)

| Bank No. | Signal | 484 fpBGA | 676 fpBGA |
|----------|-------------|-----------|-----------|
| 1 | 3A-4 | V4 | AJ4 |
| 1 | 3A-2 | U7 | AK3 |
| 1 | 3A-0 | AB2 | AK4 |
| 1 | 3D-0 | V7 | AJ5 |
| 1 | 3D-2 | AA5 | AH6 |
| 1 | GNDIO1 | GND | GND |
| 1 | 3D-4 | AB3 | AF8 |
| 1 | 3D-6 | Y6 | AG7 |
| 1 | 3D-8 | AB4 | AK5 |
| 1 | 3D-10 | Y7 | AJ6 |
| 1 | 3D-12 | AB5 | AH7 |
| 1 | 3D-14 | V8 | AK6 |
| 1 | 3D-16 | AA7 | AJ7 |
| 1 | 3D-18 | Y8 | AH8 |
| 1 | 3D-20 | AB6 | AG9 |
| 1 | 3D-22 | W8 | AK7 |
| 1 | 3D-24 | AA8 | AF10 |
| 1 | 3D-26 | Y10 | AJ8 |
| 1 | GNDIO1 | GND | GND |
| 1 | 3D-28 | U8 | AH9 |
| 1 | 3D-30 | AB7 | AK8 |
| 1 | 3C-0 | U9 | AJ9 |
| 1 | 3C-2 | AA9 | AH10 |
| 1 | 3C-4 | W9 | AK9 |
| 1 | 3C-6 | AB8 | AG11 |
| 1 | 3C-8 | U10 | AJ10 |
| 1 | 3C-10 | AB9 | AF12 |
| 1 | 3C-12 | V11 | AH11 |
| 1 | 3C-14/VREF1 | AA10 | AK10 |
| 1 | 3C-16 | V10 | AJ11 |
| 1 | 3C-18 | AB10 | AK11 |
| 1 | GNDIO1 | GND | GND |
| 1 | 3C-20 | W10 | AH12 |
| 1 | 3C-22 | W11 | AJ12 |
| 1 | 3C-24 | U11 | AK12 |
| 1 | 3C-26 | AA11 | AH13 |
| 1 | 3C-28 | V12 | AJ13 |
| 1 | 3C-30 | AB11 | AK13 |
| 2 | 4C-30 | W12 | AK18 |
| 2 | 4C-28 | Y11 | AK19 |
| 2 | 4C-26 | Y12 | AJ19 |
| 2 | 4C-24 | AB12 | AH19 |
| 2 | 4C-22 | U12 | AK20 |

| Bank No. | Signal | 484 fpBGA | 676 fpBGA |
|----------|-------------|-----------|-----------|
| 2 | 4C-20 | AA12 | AJ20 |
| 2 | GNDIO2 | GND | GND |
| 2 | 4C-18 | Y13 | AK21 |
| 2 | 4C-16 | AB13 | AH20 |
| 2 | 4C-14 | W13 | AF19 |
| 2 | 4C-12/VREF2 | AA13 | AJ21 |
| 2 | 4C-10 | U13 | AG20 |
| 2 | 4C-8 | AB14 | AK22 |
| 2 | 4C-6 | V13 | AH21 |
| 2 | 4C-4 | AA14 | AJ22 |
| 2 | 4C-2 | U14 | AK23 |
| 2 | 4C-0 | AB15 | AH22 |
| 2 | 4D-30 | Y15 | AJ23 |
| 2 | 4D-28 | AB16 | AK24 |
| 2 | GNDIO2 | GND | GND |
| 2 | 4D-26 | AA15 | AF21 |
| 2 | 4D-24 | W14 | AG22 |
| 2 | 4D-22 | AB17 | AH23 |
| 2 | 4D-20 | Y16 | AJ24 |
| 2 | 4D-18 | AA16 | AK25 |
| 2 | 4D-16 | Y17 | AH24 |
| 2 | 4D-14 | AB18 | AJ25 |
| 2 | 4D-12 | V15 | AK26 |
| 2 | 4D-10 | AB19 | AJ26 |
| 2 | 4D-8 | W15 | AH25 |
| 2 | 4D-6 | AB20 | AG24 |
| 2 | 4D-4 | AA18 | AF23 |
| 2 | GNDIO2 | GND | GND |
| 2 | 4D-2 | U15 | AK27 |
| 2 | 4D-0 | W17 | AK28 |
| 2 | 4A-0 | U16 | AJ27 |
| 2 | 4A-2 | AA19 | AH26 |
| 2 | 4A-4 | V16 | AE23 |
| 2 | 4A-6 | AB21 | AK29 |
| 2 | 4A-8 | NC | AJ28 |
| 2 | 4A-10 | NC | AH27 |
| 2 | GNDIO2 | GND | GND |
| 2 | 4A-12 | NC | AG26 |
| 2 | 4A-14 | NC | AF25 |
| 2 | 4A-16 | Y18 | AJ29 |
| 2 | 4A-18 | W18 | AG27 |
| 2 | 4A-20 | AA20 | AJ30 |
| 2 | 4A-22 | W19 | AH29 |

ispMACH 51024VG Logic Signal Connections (Continued)

| Bank No. | Signal | 484 fpBGA | 676 fpBGA |
|----------|--------|-----------|-----------|
| 2 | 4A-24 | Y19 | AE25 |
| 2 | 4A-26 | V19 | AG28 |
| 2 | GNDIO2 | GND | GND |
| 2 | 4A-28 | Y21 | AF27 |
| 2 | 4A-30 | W20 | AE26 |
| 2 | 4B-30 | AA22 | AH30 |
| 2 | 4B-28 | W21 | AG29 |
| 2 | 4B-26 | Y22 | AF28 |
| 2 | 4B-24 | V20 | AG30 |
| 2 | 4B-22 | V21 | AF29 |
| 2 | 4B-20 | W22 | AC25 |
| 2 | 4B-18 | V18 | AE28 |
| 2 | 4B-16 | U20 | AF30 |
| 2 | 4B-14 | V22 | AD27 |
| 2 | 4B-12 | U19 | AE29 |
| 2 | GNDIO2 | GND | GND |
| 2 | 4B-10 | U17 | AC26 |
| 2 | 4B-8 | U22 | AD28 |
| 2 | 4B-6 | T20 | AE30 |
| 2 | 4B-4 | T21 | AD29 |
| 2 | 4B-2 | T17 | AC28 |
| 2 | 4B-0 | R20 | AD30 |
| 2 | 5A-0 | NC | AC29 |
| 2 | 5A-2 | NC | AB27 |
| 2 | 5A-4 | NC | AC30 |
| 2 | 5A-6 | NC | AB28 |
| 2 | 5A-8 | NC | AA26 |
| 2 | 5A-10 | NC | AB29 |
| 2 | GNDIO2 | GND | GND |
| 2 | 5A-12 | NC | AB30 |
| 2 | 5A-14 | NC | AA28 |
| 2 | 5A-16 | NC | AA29 |
| 2 | 5A-18 | NC | AA30 |
| 2 | 5A-20 | NC | Y27 |
| 2 | 5A-22 | NC | Y28 |
| 2 | 5A-24 | NC | Y29 |
| 2 | 5A-26 | NC | W26 |
| 2 | 5A-28 | NC | Y30 |
| 2 | 5A-30 | NC | W28 |
| 2 | GNDIO2 | GND | GND |
| 2 | 5B-30 | NC | W29 |
| 2 | 5B-28 | NC | W30 |
| 2 | 5B-26 | NC | V25 |

| Bank No. | Signal | 484 fpBGA | 676 fpBGA |
|----------|----------------|-----------|-----------|
| 2 | 5B-24 | NC | V26 |
| 2 | 5B-22 | NC | V27 |
| 2 | 5B-20 | NC | V28 |
| 2 | 5B-18 | NC | V29 |
| 2 | 5B-16 | NC | V30 |
| 2 | 5B-14 | NC | U25 |
| 2 | 5B-12 | NC | U27 |
| 2 | GNDIO2 | GND | GND |
| 2 | 5B-10 | NC | U28 |
| 2 | 5B-8 | NC | U29 |
| 2 | 5B-6 | NC | U30 |
| 2 | 5B-4 | NC | T27 |
| 2 | 5B-2 | NC | T28 |
| 2 | 5B-0 | NC | T29 |
| 3 | 6B-0 | R21 | T30 |
| 3 | 6B-2 | T22 | R29 |
| 3 | 6B4/PLL_FBK1 | P21 | R27 |
| 3 | 6B6/PLL_RST1 | N20 | R28 |
| 3 | 6B-8 | R22 | R30 |
| 3 | 6B-10 | N21 | P30 |
| 3 | GNDIO3 | GND | GND |
| 3 | 6B-12 | M18 | P29 |
| 3 | 6B-14 | N19 | P28 |
| 3 | 6B-16 | P22 | P27 |
| 3 | 6B-18 | M20 | N30 |
| 3 | 6B-20 | N22 | N29 |
| 3 | 6B-22 | N17 | N28 |
| 3 | 6B-24 | M19 | N27 |
| 3 | 6B-26 | M21 | N25 |
| 3 | 6B-28 | L19 | M30 |
| 3 | 6B-30/CLK_OUT1 | L20 | M29 |
| 3 | GNDIO3 | GND | GND |
| 3 | 6A-30 | M17 | M28 |
| 3 | 6A-28 | M22 | L30 |
| 3 | 6A-26 | K20 | M26 |
| 3 | 6A-24 | L18 | L29 |
| 3 | 6A-22 | L21 | L28 |
| 3 | 6A-20 | K19 | L27 |
| 3 | 6A-18 | L22 | K30 |
| 3 | 6A-16 | K17 | K29 |
| 3 | 6A-14 | K22 | K28 |
| 3 | 6A-12 | L17 | J30 |
| 3 | GNDIO3 | GND | GND |

ispMACH 51024VG Logic Signal Connections (Continued)

| Bank No. | Signal | 484 fpBGA | 676 fpBGA |
|----------|--------|-----------|-----------|
| 3 | 6A-10 | K21 | J29 |
| 3 | 6A-8 | K18 | K26 |
| 3 | 6A-6 | J17 | J28 |
| 3 | 6A-4 | J19 | H30 |
| 3 | 6A-2 | J22 | J27 |
| 3 | 6A-0 | J21 | H29 |
| 3 | 7B-0 | H19 | G30 |
| 3 | 7B-2 | H20 | H28 |
| 3 | 7B-4 | H17 | G29 |
| 3 | 7B-6 | H18 | F30 |
| 3 | 7B-8 | H22 | G28 |
| 3 | 7B-10 | H21 | H26 |
| 3 | GNDIO3 | GND | GND |
| 3 | 7B-12 | G20 | F29 |
| 3 | 7B-14 | G22 | G27 |
| 3 | 7B-16 | G17 | E30 |
| 3 | 7B-18 | G21 | F28 |
| 3 | 7B-20 | F19 | H25 |
| 3 | 7B-22 | F20 | E29 |
| 3 | 7B-24 | F22 | D30 |
| 3 | 7B-26 | E22 | E28 |
| 3 | 7B-28 | E19 | D29 |
| 3 | 7B-30 | E20 | C30 |
| 3 | 7A-30 | D22 | F26 |
| 3 | 7A-28 | D21 | E27 |
| 3 | GNDIO3 | GND | GND |
| 3 | 7A-26 | D20 | D28 |
| 3 | 7A-24 | C22 | F25 |
| 3 | 7A-22 | C18 | C29 |
| 3 | 7A-20 | C19 | B30 |
| 3 | 7A-18 | D17 | D27 |
| 3 | 7A-16 | C21 | E25 |
| 3 | 7A-14 | NC | D26 |
| 3 | 7A-12 | NC | C27 |
| 3 | GNDIO3 | GND | GND |
| 3 | 7A-10 | NC | B28 |
| 3 | 7A-8 | NC | A29 |
| 3 | 7A-6 | B22 | F23 |
| 3 | 7A-4 | D18 | C26 |
| 3 | 7A-2 | B20 | B27 |
| 3 | 7A-0 | F17 | A28 |
| 3 | 7D-0 | B19 | A27 |
| 3 | 7D-2 | C17 | B26 |

| Bank No. | Signal | 484 fpBGA | 676 fpBGA |
|----------|-------------|-----------|-----------|
| 3 | GNDIO3 | GND | GND |
| 3 | 7D-4 | A21 | E23 |
| 3 | 7D-6 | D15 | D24 |
| 3 | 7D-8 | A20 | C25 |
| 3 | 7D-10 | C16 | A26 |
| 3 | 7D-12 | A19 | B25 |
| 3 | 7D-14 | F16 | C24 |
| 3 | 7D-16 | B16 | A25 |
| 3 | 7D-18 | D14 | B24 |
| 3 | 7D-20 | A18 | C23 |
| 3 | 7D-22 | F15 | D22 |
| 3 | 7D-24 | A17 | A24 |
| 3 | 7D-26 | B15 | E21 |
| 3 | GNDIO3 | GND | GND |
| 3 | 7D-28 | A16 | B23 |
| 3 | 7D-30 | F14 | C22 |
| 3 | 7C-0 | C15 | A23 |
| 3 | 7C-2 | D13 | B22 |
| 3 | 7C-4 | E15 | C21 |
| 3 | 7C-6 | F13 | A22 |
| 3 | 7C-8 | B14 | D20 |
| 3 | 7C-10 | E13 | B21 |
| 3 | 7C-12/VREF3 | A15 | E19 |
| 3 | 7C-14 | D12 | C20 |
| 3 | 7C-16 | A14 | A21 |
| 3 | 7C-18 | B13 | B20 |
| 3 | GNDIO3 | GND | GND |
| 3 | 7C-20 | A13 | A20 |
| 3 | 7C-22 | B12 | C19 |
| 3 | 7C-24 | C13 | B19 |
| 3 | 7C-26 | A12 | A19 |
| 3 | 7C-28 | C12 | B18 |
| 3 | 7C-30 | A11 | A18 |
| — | GCLK0 | P6 | R5 |
| — | GCLK1 | R6 | T6 |
| — | GCLK2 | P17 | R25 |
| — | GCLK3 | P19 | P26 |
| — | GOE0 | R18 | T26 |
| — | GOE1 | R17 | R26 |
| — | RESETB | R19 | T25 |
| — | TCK | R3 | U5 |
| — | TDI | R2 | T5 |
| — | TDO | R4 | V5 |

ispMACH 51024VG Logic Signal Connections (Continued)

| Bank No. | Signal | 484 fpBGA | 676 fpBGA |
|----------|--------|-----------|-----------|
| — | TMS | T1 | T4 |
| — | TOE | T18 | U26 |

Signal Configuration

ispMACH 5768VG 256-ball fpBGA

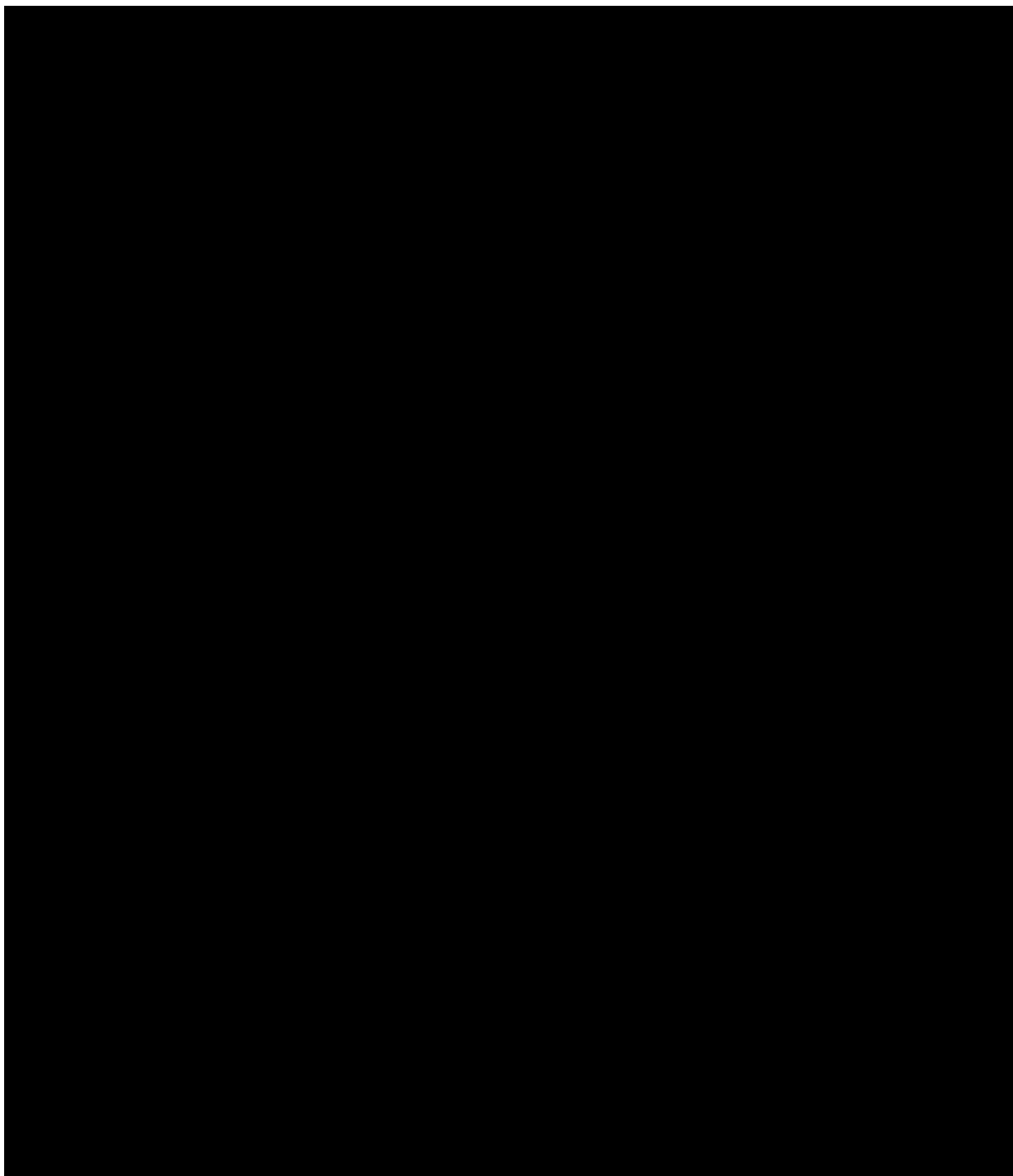

Signal Configuration

ispMACH 5768VG and 51024VG 484-ball fpBGA

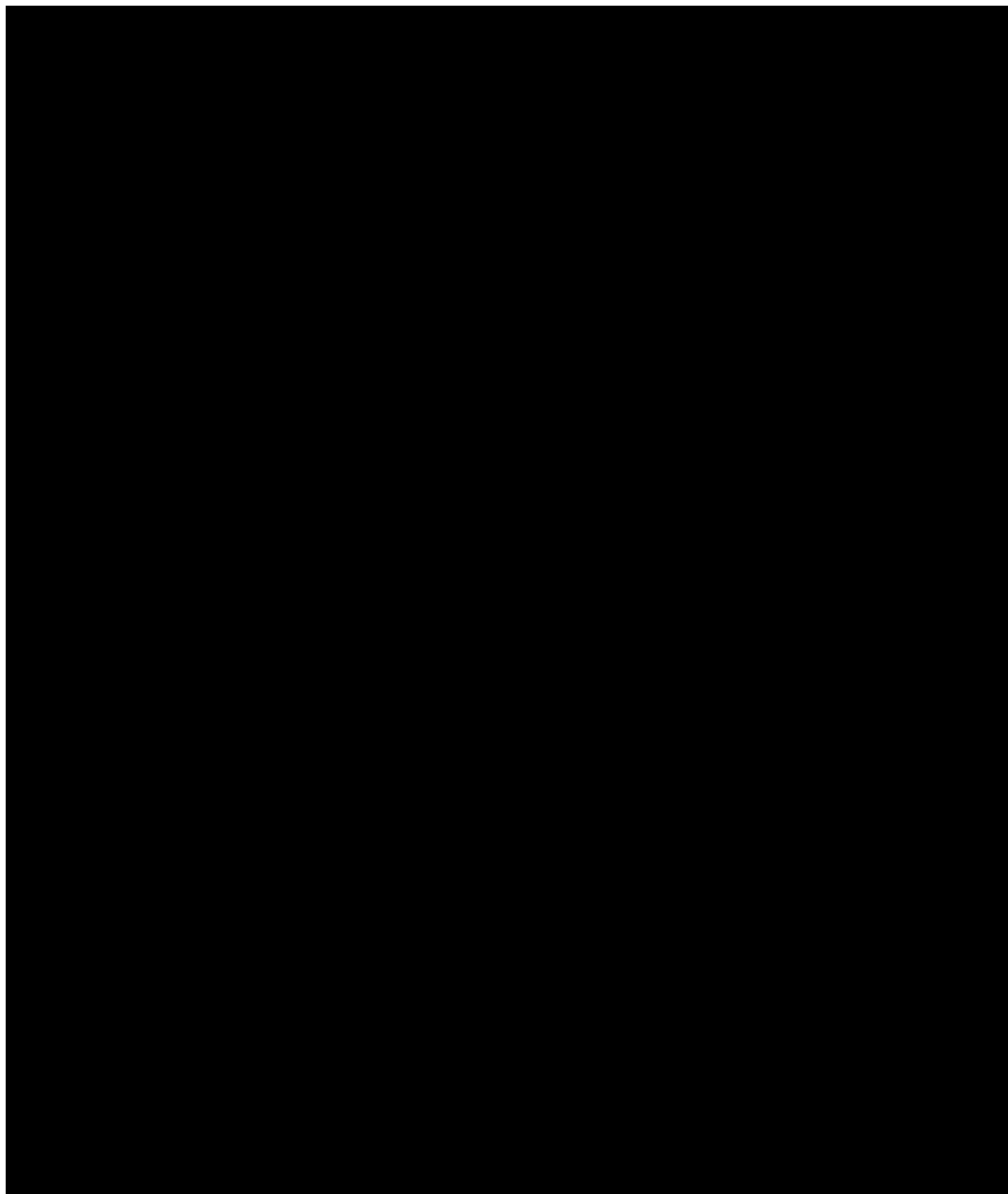

Signal Configuration

ispMACH 51024VG 676-ball fpBGA

| | 30 | 29 | 28 | 27 | 26 | 25 | 24 | 23 | 22 | 21 | 20 | 19 | 18 | 17 | 16 | 15 | 14 | 13 | 12 | 11 | 10 | 9 | 8 | 7 | 6 | 5 | 4 | 3 | 2 | 1 | | |
|----|-----|---------------|---------------|---------------|-------|--------|-------|-----|-------|-------|-------|-----------|-----------------|-----------------|-----------------|-----------------|-----------------|-----------------|-----|-----------|-------|-------|-------|-------|---------------|-------|---------------|---------------|-----|-----|-----|----|
| A | GND | I/O | I/O | I/O | I/O | I/O | I/O | I/O | I/O | I/O | I/O | I/O | I/O | NC ¹ | NC ¹ | NC ¹ | NC ¹ | I/O | I/O | I/O | I/O | I/O | I/O | I/O | I/O | I/O | I/O | I/O | I/O | GND | A | |
| B | I/O | VCC | I/O | I/O | I/O | I/O | I/O | I/O | I/O | I/O | I/O | I/O | I/O | NC ¹ | NC ¹ | NC ¹ | NC ¹ | I/O | I/O | I/O | I/O | I/O | I/O | I/O | I/O | I/O | I/O | I/O | I/O | GND | B | |
| C | I/O | I/O | GND | I/O | I/O | I/O | I/O | I/O | I/O | I/O | I/O | I/O | NC ¹ | NC ¹ | NC ¹ | NC ¹ | NC ¹ | NC ¹ | I/O | I/O/VREF0 | I/O | I/O | I/O | I/O | I/O | I/O | I/O | GND | I/O | I/O | C | |
| D | I/O | I/O | I/O | I/O | I/O | VCC | I/O | GND | I/O | VCC | I/O | VCC | NC ¹ | NC ¹ | NC ¹ | NC ¹ | NC ¹ | NC ¹ | VCC | I/O | VCC | I/O | GND | I/O | VCC | I/O | I/O | I/O | I/O | I/O | D | |
| E | I/O | I/O | I/O | I/O | VCC03 | I/O | VCC03 | I/O | VCC03 | I/O | VCC03 | I/O/VREF3 | NC ¹ | NC ¹ | NC ¹ | NC ¹ | NC ¹ | NC ¹ | I/O | VCC03 | I/O | VCC03 | I/O | VCC03 | I/O | VCC03 | I/O | I/O | I/O | I/O | E | |
| F | I/O | I/O | I/O | VCC | I/O | I/O | GND | I/O | GND | VCC03 | GND | GND | NC ¹ | NC ¹ | NC ¹ | NC ¹ | NC ¹ | NC ¹ | GND | GND | VCC03 | GND | I/O | GND | I/O | I/O | VCC | I/O | I/O | I/O | F | |
| G | I/O | I/O | I/O | I/O | VCC03 | GND | | | | | | | | | | | | | | | | | GND | VCC03 | I/O | I/O | I/O | I/O | G | | | |
| H | I/O | I/O | I/O | GND | I/O | I/O | | | | | | | | | | | | | | | | | I/O | I/O | GND | I/O | I/O | I/O | H | | | |
| J | I/O | I/O | I/O | I/O | VCC03 | GND | | | | | | | | | | | | | | | | | GND | VCC03 | I/O | I/O | I/O | I/O | J | | | |
| K | I/O | I/O | I/O | VCC | I/O | VCC03 | | | | | | | | | | | | | | | | | VCC03 | I/O | VCC | I/O | I/O | I/O | K | | | |
| L | I/O | I/O | I/O | I/O | VCC03 | GND | | | | | | | | | | | | | | | | | GND | VCC03 | I/O | I/O | I/O | I/O | L | | | |
| M | I/O | I/O/VCLK_OUT1 | I/O | VCC | I/O | GND | | | | | | | | | | | | | | | | | GND | I/O | VCC | I/O | I/O/VCLK_OUT1 | I/O | M | | | |
| N | I/O | I/O | I/O | I/O | VCC03 | I/O | | | | | | | | | | | | | | | | | I/O | I/O | I/O | I/O | I/O | I/O | N | | | |
| P | I/O | I/O | I/O | I/O | GCLK3 | GNDP1 | | | | | | | | | | | | | | | | | I/O | VCC03 | I/O | I/O | I/O | I/O/VCLK_OUT1 | P | | | |
| R | I/O | I/O | I/O/VPLL_REF1 | I/O/VPLL_REF2 | GOE1 | GCLK2 | | | | | | | | | | | | | | | | | GNDP0 | GCLK0 | I/O/VPLL_REF1 | I/O | I/O | I/O | R | | | |
| T | I/O | I/O | I/O | I/O | GOE0 | RESETB | | | | | | | | | | | | | | | | | GCLK1 | TDI | TMS | I/O | I/O | I/O | T | | | |
| U | I/O | I/O | I/O | I/O | TOE | I/O | | | | | | | | | | | | | | | | | VCCJ | TCK | I/O | I/O | I/O | I/O | U | | | |
| V | I/O | I/O | I/O | I/O | I/O | I/O | | | | | | | | | | | | | | | | | I/O | TDO | I/O | I/O | I/O | I/O | V | | | |
| W | I/O | I/O | I/O | VCC | I/O | GND | | | | | | | | | | | | | | | | | GND | I/O | VCC | I/O | I/O | I/O | W | | | |
| Y | I/O | I/O | I/O | I/O | VCC02 | GND | | | | | | | | | | | | | | | | | GND | VCC01 | I/O | I/O | I/O | I/O | Y | | | |
| AA | I/O | I/O | I/O | VCC | I/O | VCC02 | | | | | | | | | | | | | | | | | VCC01 | I/O | VCC | I/O | I/O | I/O | AA | | | |
| AB | I/O | I/O | I/O | I/O | VCC02 | GND | | | | | | | | | | | | | | | | | GND | VCC01 | I/O | I/O | I/O | I/O | AB | | | |
| AC | I/O | I/O | I/O | GND | I/O | I/O | | | | | | | | | | | | | | | | | I/O | I/O | GND | I/O | I/O | I/O | AC | | | |
| AD | I/O | I/O | I/O | I/O | VCC02 | GND | | | | | | | | | | | | | | | | | GND | VCC01 | I/O | I/O | I/O | I/O | AD | | | |
| AE | I/O | I/O | I/O | VCC | I/O | I/O | GND | I/O | GND | VCC02 | GND | GND | NC ¹ | NC ¹ | NC ¹ | NC ¹ | NC ¹ | NC ¹ | GND | GND | VCC01 | GND | I/O | GND | I/O | I/O | VCC | I/O | I/O | I/O | AE | |
| AF | I/O | I/O | I/O | I/O | VCC02 | I/O | VCC02 | I/O | VCC02 | I/O | VCC02 | I/O | NC ¹ | NC ¹ | NC ¹ | NC ¹ | NC ¹ | NC ¹ | I/O | VCC01 | I/O | VCC01 | I/O | VCC01 | I/O | VCC01 | I/O | I/O | I/O | I/O | AF | |
| AG | I/O | I/O | I/O | I/O | I/O | VCC | I/O | GND | I/O | VCC | I/O | VCC | NC ¹ | NC ¹ | NC ¹ | NC ¹ | NC ¹ | NC ¹ | VCC | I/O | VCC | I/O | GND | I/O | VCC | I/O | I/O | I/O | I/O | I/O | AG | |
| AH | I/O | I/O | GND | I/O | I/O | I/O | I/O | I/O | I/O | I/O | I/O | I/O | NC ¹ | NC ¹ | NC ¹ | NC ¹ | NC ¹ | I/O | I/O | I/O | I/O | I/O | I/O | I/O | I/O | I/O | I/O | I/O | GND | I/O | I/O | AH |
| AJ | I/O | I/O | I/O | I/O | I/O | I/O | I/O | I/O | I/O | I/O | I/O | I/O | NC ¹ | NC ¹ | NC ¹ | NC ¹ | NC ¹ | I/O | I/O | I/O | I/O | I/O | I/O | I/O | I/O | I/O | I/O | I/O | I/O | VCC | I/O | AJ |
| AK | GND | I/O | I/O | I/O | I/O | I/O | I/O | I/O | I/O | I/O | I/O | I/O | I/O | NC ¹ | NC ¹ | NC ¹ | NC ¹ | I/O | I/O | I/O | I/O | I/O | I/O | I/O | I/O | I/O | I/O | I/O | I/O | I/O | GND | AK |
| | 30 | 29 | 28 | 27 | 26 | 25 | 24 | 23 | 22 | 21 | 20 | 19 | 18 | 17 | 16 | 15 | 14 | 13 | 12 | 11 | 10 | 9 | 8 | 7 | 6 | 5 | 4 | 3 | 2 | 1 | | |

ispMACH 51024VG
Bottom View

676BGA/51024VG

1. NCs are not to be connected to any active signals, VCC or GND.

Note: Ball A1 indicator dot on top side of package.

Part Number Description

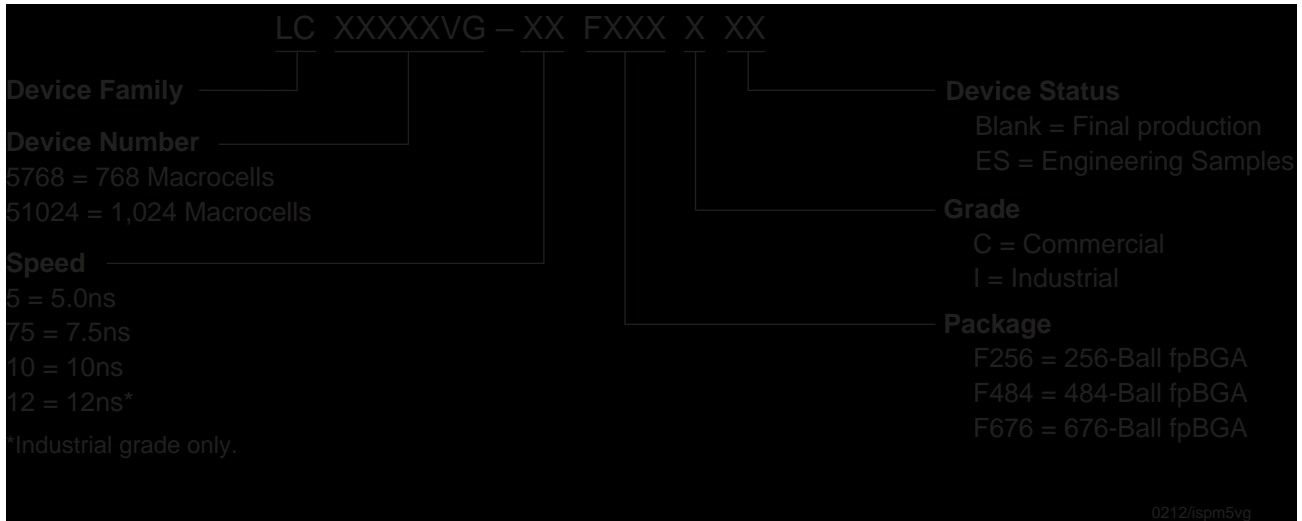

Ordering Information

Commercial

| Part Number | Package | Pin Count | Macrocells | Tpd | Voltage |
|-------------------|---------|-----------|------------|-----|---------|
| LC51024VG-5F484C | fpBGA | 484 | 1024 | 5 | 3.3 |
| LC51024VG-75F484C | fpBGA | 484 | 1024 | 7.5 | 3.3 |
| LC51024VG-10F484C | fpBGA | 484 | 1024 | 10 | 3.3 |
| LC51024VG-5F676C | fpBGA | 676 | 1024 | 5 | 3.3 |
| LC51024VG-75F676C | fpBGA | 676 | 1024 | 7.5 | 3.3 |
| LC51024VG-10F676C | fpBGA | 676 | 1024 | 10 | 3.3 |
| LC5768VG-5F256C | fpBGA | 256 | 768 | 5 | 3.3 |
| LC5768VG-75F256C | fpBGA | 256 | 768 | 7.5 | 3.3 |
| LC5768VG-10F256C | fpBGA | 256 | 768 | 10 | 3.3 |
| LC5768VG-5F484C | fpBGA | 484 | 768 | 5 | 3.3 |
| LC5768VG-75F484C | fpBGA | 484 | 768 | 7.5 | 3.3 |
| LC5768VG-10F484C | fpBGA | 484 | 768 | 10 | 3.3 |

Note: the ispMACH 5000VG family is dual-marked with both Commercial and Industrial grades. The Commercial speed grade is one speed grade faster (i.e. LC51024VG-75F484C) than the Industrial speed grade (i.e. LC51024VG-10F484I).

Industrial

| Part Number | Package | Pin Count | Macrocells | Tpd | Voltage |
|-------------------|---------|-----------|------------|-----|---------|
| LC51024VG-75F484I | fpBGA | 484 | 1024 | 7.5 | 3.3 |
| LC51024VG-10F484I | fpBGA | 484 | 1024 | 10 | 3.3 |
| LC51024VG-12F484I | fpBGA | 484 | 1024 | 12 | 3.3 |
| LC51024VG-75F676I | fpBGA | 676 | 1024 | 7.5 | 3.3 |
| LC51024VG-10F676I | fpBGA | 676 | 1024 | 10 | 3.3 |
| LC51024VG-12F676I | fpBGA | 676 | 1024 | 12 | 3.3 |
| LC5768VG-75F256I | fpBGA | 256 | 768 | 7.5 | 3.3 |
| LC5768VG-10F256I | fpBGA | 256 | 768 | 10 | 3.3 |
| LC5768VG-12F256I | fpBGA | 256 | 768 | 12 | 3.3 |
| LC5768VG-75F484I | fpBGA | 484 | 768 | 7.5 | 3.3 |
| LC5768VG-10F484I | fpBGA | 484 | 768 | 10 | 3.3 |
| LC5768VG-12F484I | fpBGA | 484 | 768 | 12 | 3.3 |

Note: the ispMACH 5000VG family is dual-marked with both Commercial and Industrial grades. The Commercial speed grade is one speed grade faster (i.e. LC51024VG-75F484C) than the Industrial speed grade (i.e. LC51024VG-10F484I).

For Further Information

In addition to this data sheet, the following technical notes may be helpful when designing with the ispMACH 5000VG family:

- *ispMACH 5000VG sysIO Design and Usage Guidelines (TN1000)*
- *ispMACH 5000VG Timing Model Design and Usage Guidelines (TN1001)*
- *Power Estimation in ispMACH 5000VG Devices (TN1002)*
- *ispMACH 5000VG PLL Usage Guidelines (TN1003)*