

spec ref	-	dr	Wei-Long Zhang	2012/01/01	projection	MM	size	A2	scale	4:1
tolerance std	ASME Y14.5	eng	Wei-Long Zhang	2012/04/24	chr	-	ecn no	ELX-DG-011379-1	rel level	Released
surface	✓	appr	Pei-Ming Zheng	2012/04/24	product family	CARD EDGE	cat. no.	10119864	rev	B
ASME Y14.5	linear	0.X	±0.3	0.XX	±0.10	0.XXX	±0.050	angular	0°	±2°

FCI VERT RECT (32P 40S)
 HIGH POWER CARD EDGE
 www.fci.com Product - Customer Drw sheet 1 of 4

Copyright FCI. FCI

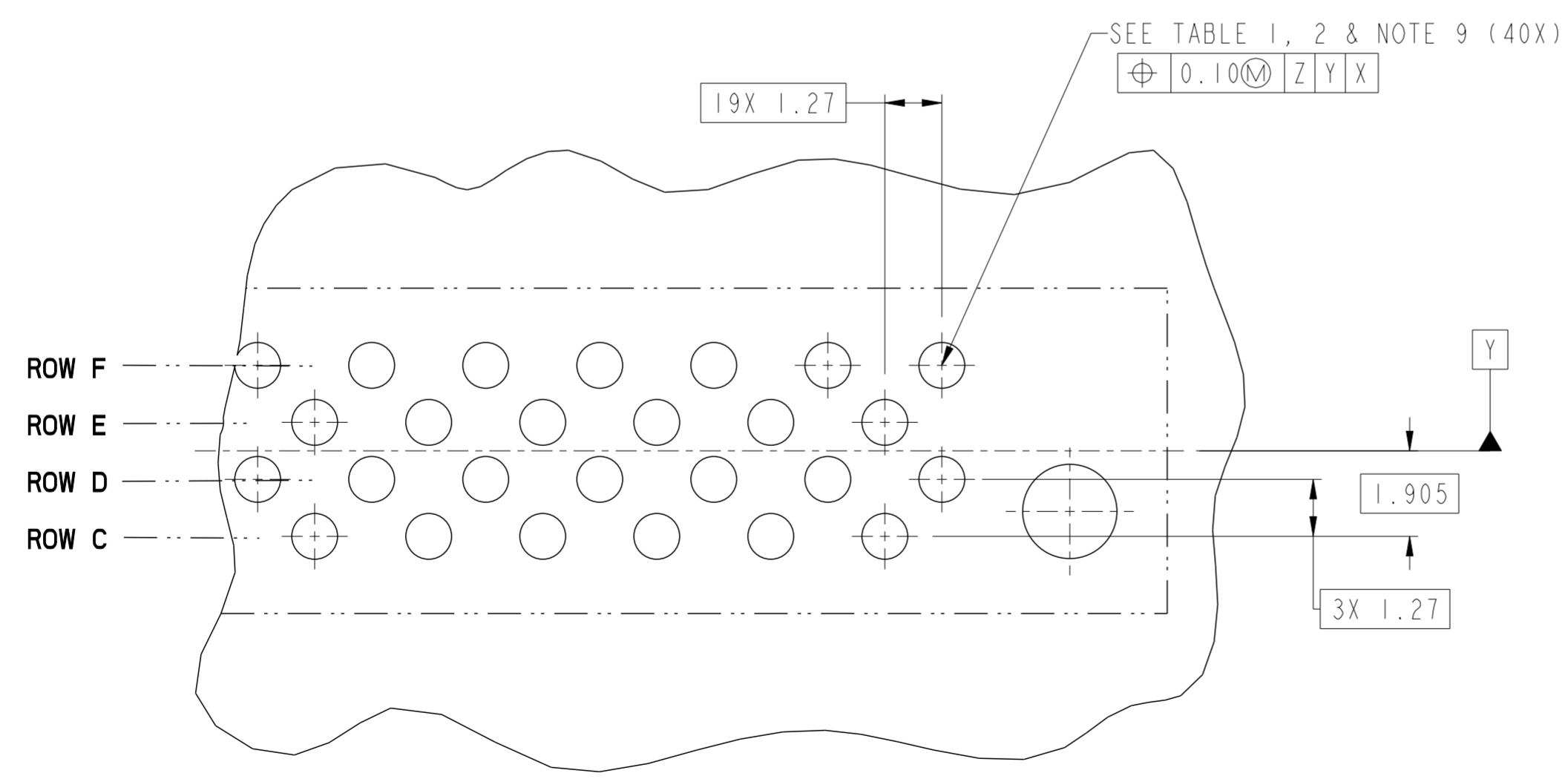
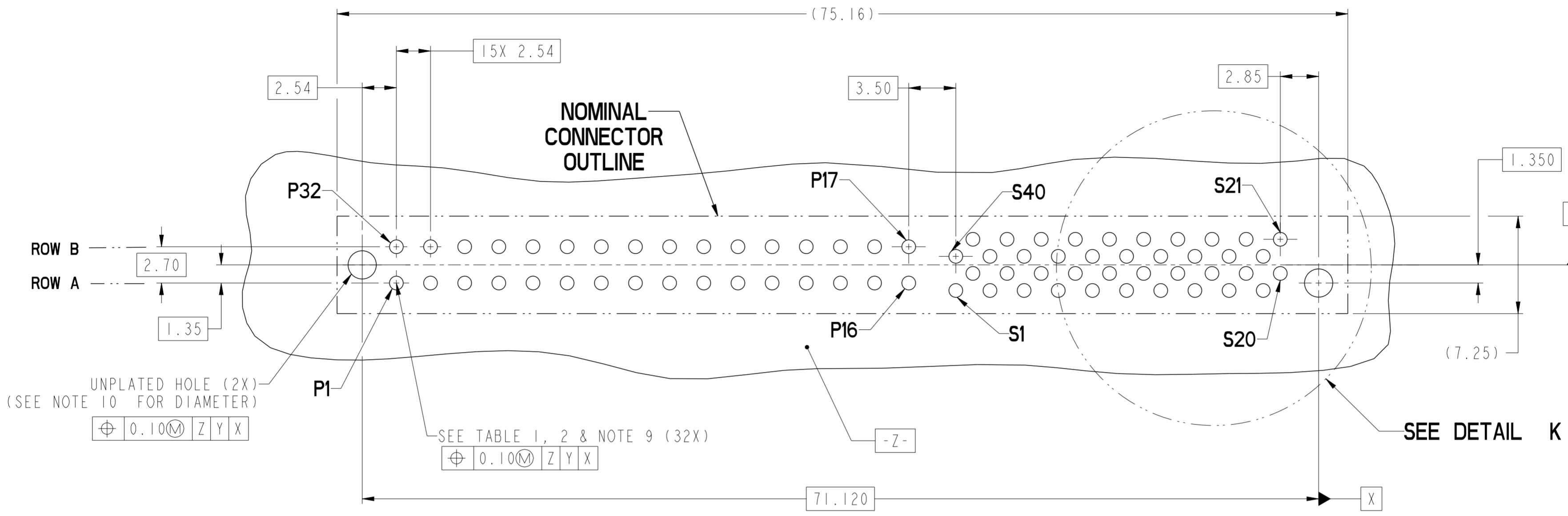

DETAIL K
SCALE 8:1

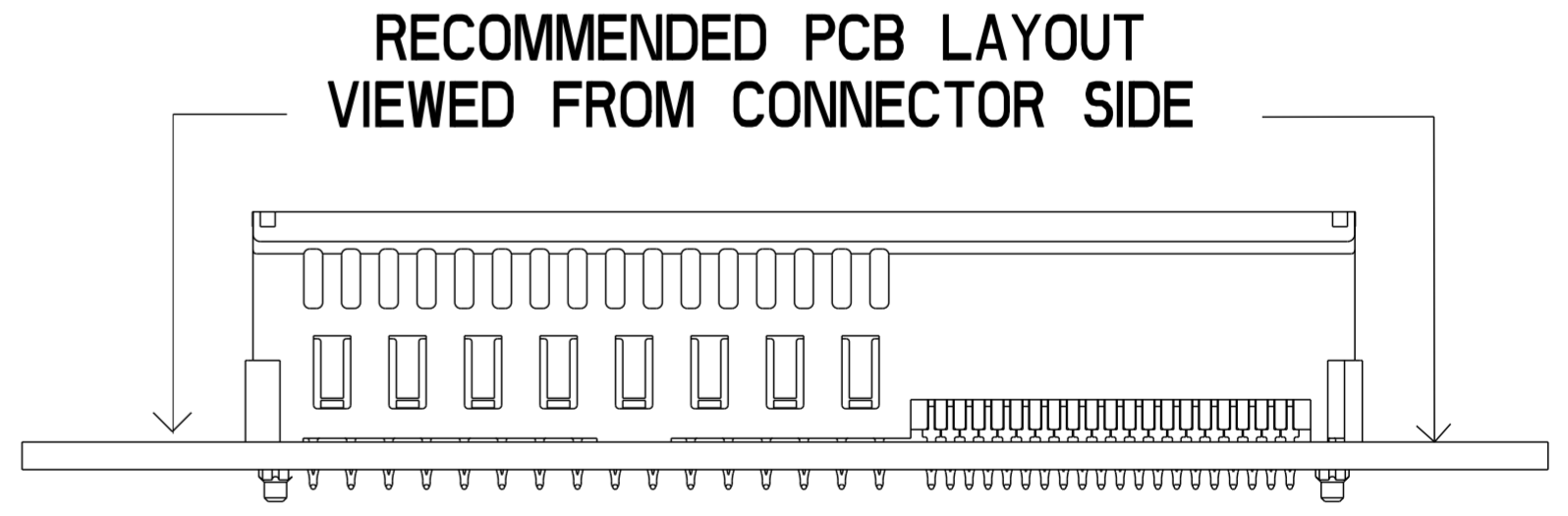

dr	Wei-Long Zhang	2012/01/01	projection	MM	size	A2	scale	4:1
eng	Wei-Long Zhang	2012/04/24			ecn no	ELX-DG-011379-1		
chr	-	-			rel level	Released		
appr	Pai-Ming Zheng	2012/04/24	product family	CARD EDGE		rel level	Released	
		title VERT RECT (32P 40S) HIGH POWER CARD EDGE	dwg no 10119864	rev B				
www.fci.com		cat. no.	-		Product - Customer Drw		sheet 2 of 4	

Copyright FCI.

CONTACT TYPE	TOP LAYER DESCRIPTION	TABLE 1 (HPCE / SOLDER TAILS) PLATED THROUGH-HOLE REQUIREMENTS				
		DRILLED HOLE DIAMETER	COPPER THICKNESS	TIN-LEAD THICKNESS	TIN THICKNESS	FINISHED HOLE DIAMETER
POWER & SIGNAL	TIN-LEAD	1.10-1.16 (1.15 DRILL)	0.025 - 0.050	0.005 - 0.015	--	0.94 - 1.10
	IMMERSION TIN	1.10-1.16 (1.15 DRILL)	0.025 - 0.050	--	0.9 - 1.5um	0.94 - 1.10
	COPPER (SEE NOTE 8)	1.10-1.16 (1.15 DRILL)	0.025 - 0.050	--	--	0.94 - 1.10

CONTACT TYPE	TOP LAYER DESCRIPTION	TABLE 2 (HPCE / PRESS-FIT TAILS) PLATED THROUGH-HOLE REQUIREMENTS				
		DRILLED HOLE DIAMETER	COPPER THICKNESS	TIN-LEAD THICKNESS	TIN THICKNESS	FINISHED HOLE DIAMETER
POWER & SIGNAL	TIN-LEAD	0.81-0.86 (0.85 DRILL)	0.025 - 0.050	0.005 - 0.015	--	0.65 - 0.80
	IMMERSION TIN	0.81-0.86 (0.85 DRILL)	0.025 - 0.050	--	0.9 - 1.5um	0.70 - 0.80
	COPPER (SEE NOTE 8)	0.81-0.86 (0.85 DRILL)	0.025 - 0.050	--	--	0.70 - 0.80

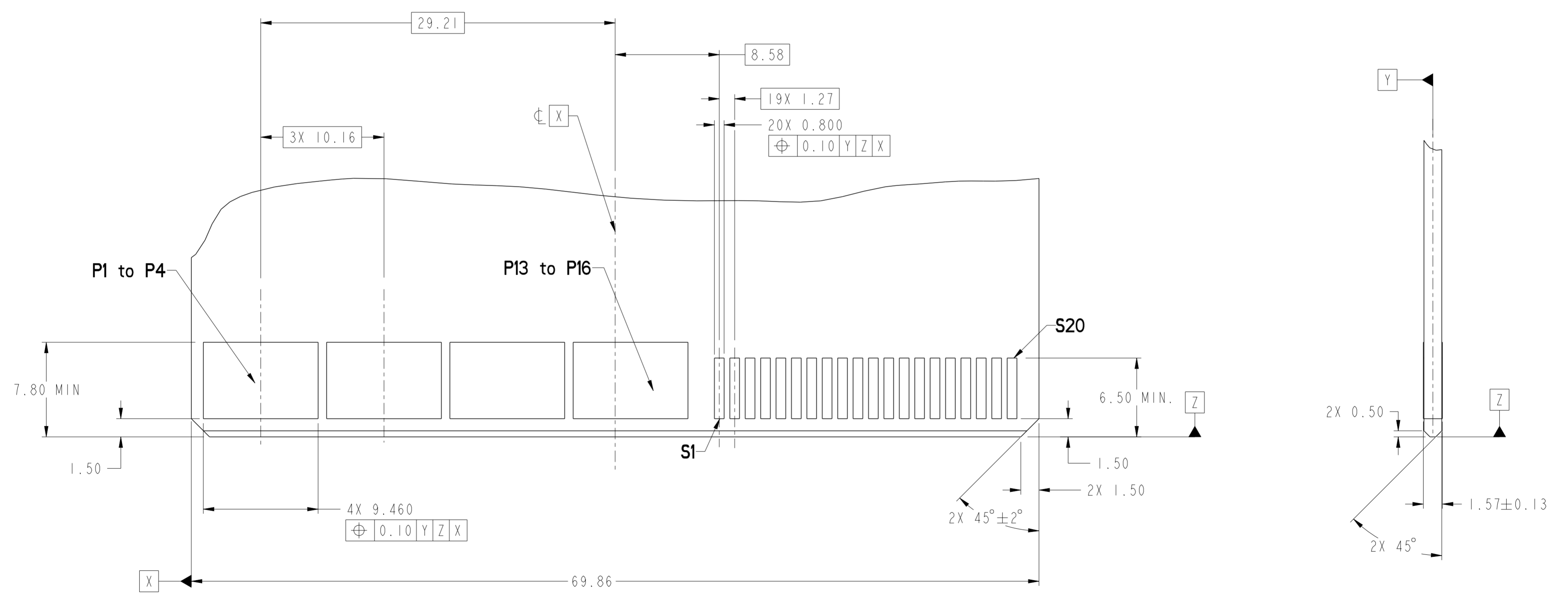

**RECOMMENDED MATING BOARD
FOOTPRINT**

dr	Wei-Long Zhang	2012/01/01	projection	MM	size	A2	scale	4:1
eng	Wei-Long Zhang	2012/04/24		MM	ecn no	ELX-DG-011379-1	rel level	Released
chr	-	-						
appr	Pai-Ming Zheng	2012/04/24	product family	CARD EDGE	rel level	Released		
		VERT RECT (32P 40S) HIGH POWER CARD EDGE			dwg no 10119864	rev B		
www.fci.com		cat. no.	Product - Customer Drw			sheet 3 of 4		

Copyright FCI. FCI

HPCE PART NUMBER (TABLE 3)

PART NUMBER	TAIL TYPE	DIM "A" TYPICAL TAIL LENGTH	DIM "B" RECOMMENDED BOARD THICKNESS
10119864-001LF	SOLDER	3.17 ±0.25	1.59 - 2.38
10119864-002LF	PRESS-FIT		1.57 MIN

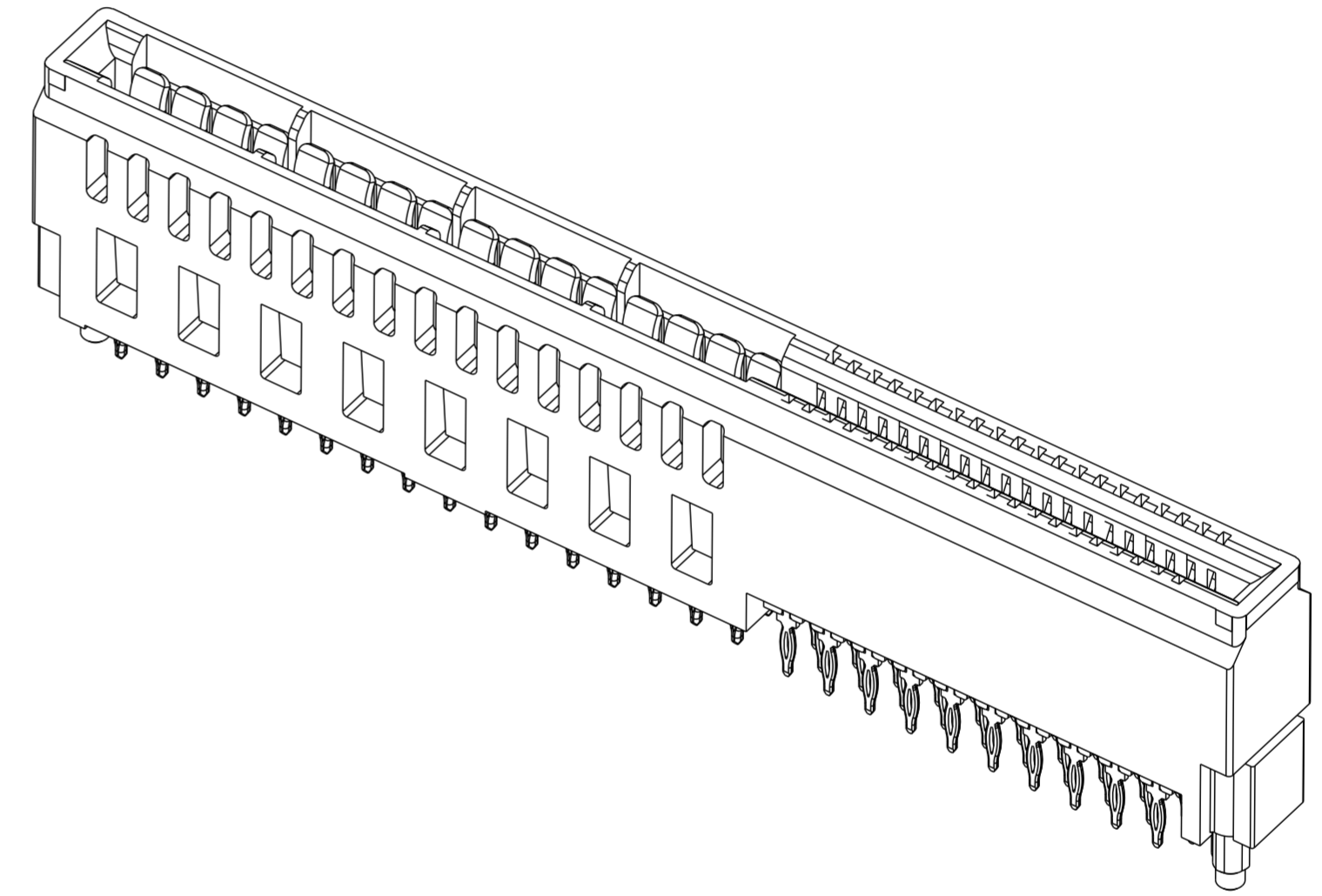

NOTES:

1. CONNECTOR MATERIALS:
 HOUSING: HIGH TEMPERATURE THERMAL PLASTIC, BLACK
 UL 94V-0 COMPLIANT
 CONTACTS: HIGH PERFORMANCE COPPER ALLOY.
2. CONTACT FINISH REF. GS-12-604 SECTION 5.2.
3. PRODUCT SPECIFICATION: GS-12-604.
4. APPLICATION SPECIFICATION: GS-20-128.
5. PRODUCT MARKING (FCI - PART NUMBER & DATE CODE) ON HOUSING IN AREA SHOWN.
6. PACKAGING MEETS FCI SPECIFICATION GS-14-937.
7. HOUSING COMPONENT WILL WITHSTAND EXPOSURE TO 260°C PEAK TEMPERATURE FOR 60 SECONDS IN A CONVECTION, INFRA-RED, OR VAPOR PHASE REFLOW OVEN.
8. COPPER PLATING THICKNESS IN CENTER OF VIA-HOLE CAN BE NO MORE THAN 0.003 LESS THAN OTHER AREAS.
9. ALL HOLE SIZES ARE FINISHED HOLE SIZES.
10. MOUNTING HOLES ARE UNPLATED
 Ø 2.40 +/- 0.1 FOR PRESS-FIT TAILS
 Ø 2.10 +/- 0.1 FOR SOLDER TAILS

dr	Wei-Long Zhang	2012/01/01	projection	MM	size	A2	scale	4:1	
eng	Wei-Long Zhang	2012/04/24			ecn no	ELX-DG-011379-1			
chr	-	-			product family	CARD EDGE	rel level	Released	
appr	Pei-Ming Zheng	2012/04/24			title	VERT RECT (32P 40S) HIGH POWER CARD EDGE		rev	B
www.fci.com		cat. no.	-		Product - Customer Drw		sheet 4 of 4		