





Drawing No.	*Rev.	Date	Page
BAE5050A-C3C	A	2021/10/27	1/15

LED APPROVAL SHEET

Part No: **BAE5050A-C3C**

NOTE : **Green Part**

MAKER			CUSTOMER	
				
R&D	QA	Sales	Checked	Approved
				

Prepared	Checked	Approved
Rachel Lee	SKY Lin	Kenneth Wu

Drawing No.	*Rev.	Date	Page
BAE5050A-C3C	A	2021/10/27	2/15

BAE5050A-C3C

- ◆ Outline(L*W*H): 5.0*5.0*1.57mm
- ◆ Good thermal dissipation & optical



Table of Contents

Product Code Method-----	2
Maximum Rating-----	2
Typical Product Characteristics-----	3
Range of Bins-----	3
Color Coordinate Comparison-----	4
Electrical Characteristics -----	5
Switching Characteristics -----	5
Data transfer time-----	6
Dimensions-----	7
PIN Configuration -----	8
Reflow Profile -----	9
Test Circuit and Handling Precautions -----	10
Packing-----	11
Precautions-----	13
Test Items and Results of Reliability-----	14

Features

- ROHS2.0 Compliant
- Packaged in 12mm tape on 7" diameter reels
- EIA STD package
- Compatible with automatic placement equipment and infrared reflow solder process
- Preconditioning: accelerate to JEDEC level 5a
- RGB and driver chip are integrated in a package, to form a complete control of pixel point with constant current.
- One pixel contains R, G, and B color that each can achieve 256 level brightness grayscale, which forms 16,777,216 combination colors. Internal clock frequency is operated at 800 kHz.
- Serial data transmission signal by only single wire.
- ESD level 2kV(HBM)

Applications

- Telecommunication, office automation, home appliances, industrial equipment
- Status indicator
- Signal and symbol luminary
- Front panel backlighting
- Full-color strip.
- Indoor decorative lighting/ curtain display

■ Product Code Method

①②③④⑤⑥⑦⑧⑨

①	②	③	④	⑤
Process Type	Category	LED Type	Lead Frame Size	Dice wavelength & luminous rank
I: Special products with IC	S: SMD LED	C: PLCC top view D: PLCC side view	5050: 5.0*5.0mm	V:red G:green B:blue C:IC

⑥	⑦	⑧	⑨
Lap Polarity	Cap Color	PCB Module Code	Flow Code
1: common anode	C: water transparent	D: article mode	A: IC Type 104 2: 12mA

■ Maximum Rating(Ta=25°C)

Parameter	Symbol	Rating	Unit
DC Forward Current	IF	12	mA
IC Power Supply Voltage	VDD	+3.8~+5.5	V
IC Input Voltage	VI	-0.4~VDD+0.4	V
Operating Temperature Range	-40°C to +85°C		
Storage Temperature Range	-40°C to +105°C		

■ Typical Product Characteristics(Ta=25°C)

Characteristics	Symbol	Min.	Typ.	Max.	Unit	Test condition	
Forward Voltage	V_F	3.8	-	5.5	V	$I_F=12mA$	
Luminous Intensity	I_v	R	-	340	-	mcd	$I_F=12mA$
		G	-	960	-		
		B	-	210	-		
		W	780	1490	-		
Dominant Wavelength	λ_d	R	615	-	630	nm	$I_F=12mA$
		G	520	-	530		
		B	460	-	475		
Color Coordinate	x	-	0.2287	-	-	$I_F=12mA$	
	y	-	0.2129	-	-		
View Angle	$2\theta_{1/2}$	-	120	-	deg	$I_F=12mA$	

■ Range of Bins

1) Luminous Intensity-White ($I_F = 12mA$)

Bin Code	Min. I_v (mcd)	Max. I_v (mcd)
14	780	1000
15	1000	1300
16	1300	1700
17	1700	2200
18	2200	2800

■ Color Coordinate Comparison-White

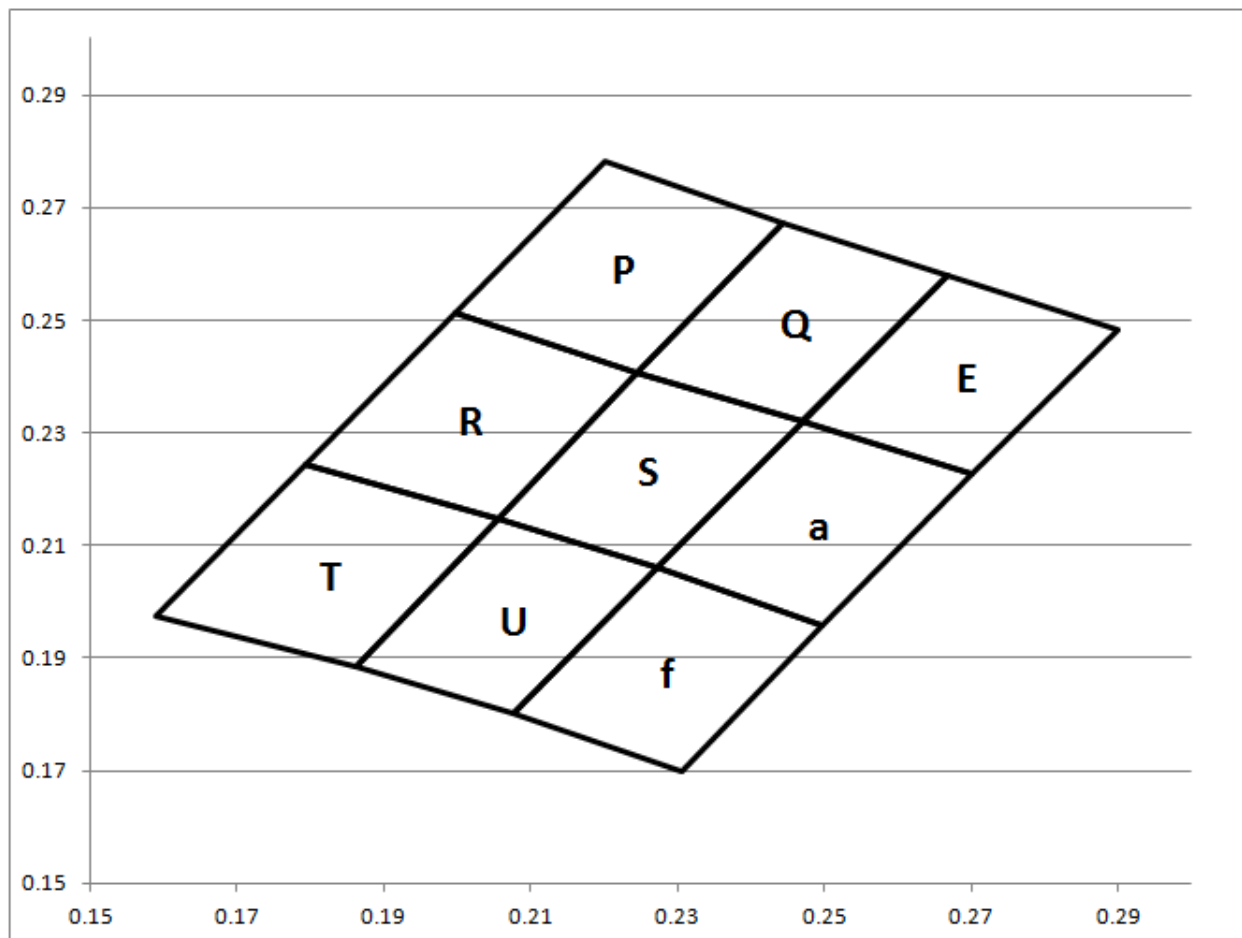

Color Rank

Bin	X	Y	X	Y	X	Y	X	Y
E	0.2667	0.2578	0.2899	0.2482	0.27	0.2227	0.247	0.232
P	0.22	0.2783	0.1996	0.2513	0.2244	0.2407	0.2444	0.2672
Q	0.2444	0.2672	0.2244	0.2407	0.2471	0.232	0.2669	0.2579
R	0.1996	0.2513	0.1792	0.2243	0.2056	0.2148	0.2244	0.2407
S	0.2244	0.2407	0.2056	0.2148	0.2273	0.2061	0.2471	0.232
a	0.2471	0.232	0.2273	0.2061	0.2498	0.1959	0.27	0.2227
T	0.1792	0.2243	0.1588	0.1973	0.1862	0.1886	0.2056	0.2148
U	0.2056	0.2148	0.1862	0.1886	0.2075	0.1802	0.2273	0.2061
f	0.2273	0.2061	0.2075	0.1802	0.2305	0.17	0.2498	0.1959

■ Electrical Characteristics (Ta=25°C)

Characteristics	Symbol	Condition	Min.	Typ.	Max.	Unit
Static current	I _{DD}	V _{DD} =4.5v, I _{out} = "OFF" "	-	0.5		mA
Input voltage level	V _{IH}	D _{IN} , SET	0.7 V _{DD}	-	-	V
	V _{IL}	D _{IN} , SET	-	-	0.3 V _{DD}	V

■ Switching Characteristics (Ta=25°C)

Characteristics	Symbol	Condition	Min.	Typ.	Max.	Unit
Rate of data signal	F _{DIN}		-	800	-	KHZ
Transfer time	T _{PLH}	D _{IN} →D _{OUT}	-	-	80	ns
	T _{PHL}				80	ns
Conversion time of IOUT R/G/B	Tr	IOUT R/G/B =12mA RL=200 Ω , CL=15pF	-	-	50	ns
	Tf				100	ns

■ Data transfer time($T_H+T_L=1.2\mu s\pm 600ns$)

1. Timing Wave Form

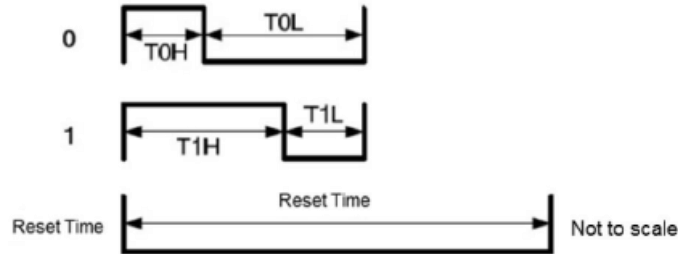

2. High Speed Mode

Item	Description	Typical	Allowance
T_{OH}	0 code,high voltage time	300ns	$\pm 150ns$
T_{1H}	1 code,high voltage time	600ns	$\pm 150ns$
T_{OL}	0 code,low voltage time	900ns	$\pm 150ns$
T_{1L}	1 code,low voltage time	600ns	$\pm 150ns$
RES	reset time	$>200\mu s$	-

Notes:

- Luminous intensity is measured with a light sensor and filter combination that approximates the CIE eye-response curve.
- $\theta_{1/2}$ is the off-axis angle at which the luminous intensity is half the axial luminous intensity.
- The dominant wavelength, λ_d is derived from CIE chromaticity diagram and represents the single wavelength which defines the color of the device. Peak Emission Wavelength Tolerance is $\pm 1nm$.

3. Composition of 24 bit data

G7	G6	G5	G4	G3	G2	G1	G0	R7	R6	R5	R4	R3	R2	R1	R0	B7	B6	B5	B4	B3	B2	B1	B0
bit23.....											bit0											

4. Data transmission method

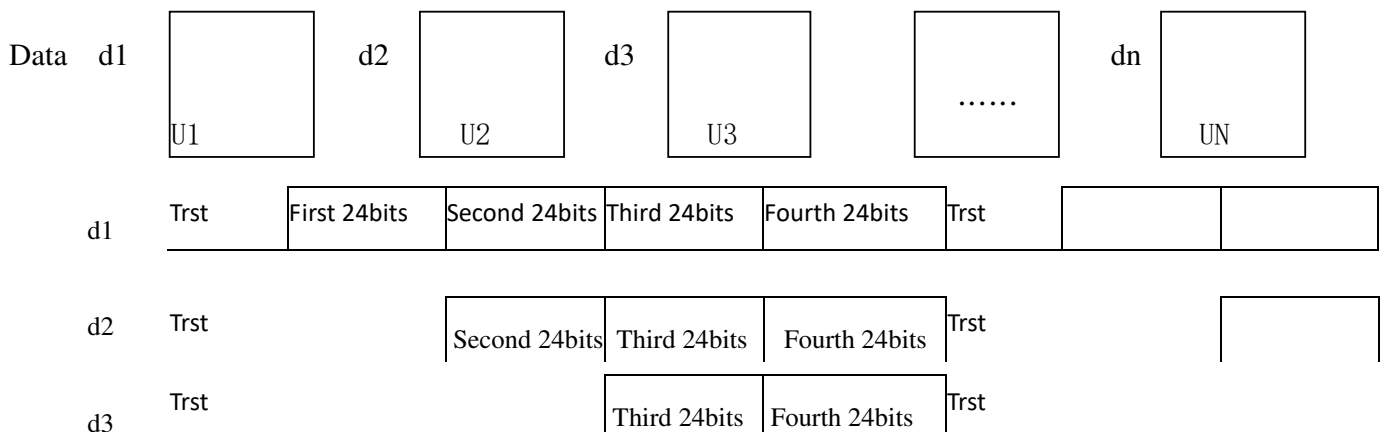

■ Dimensions

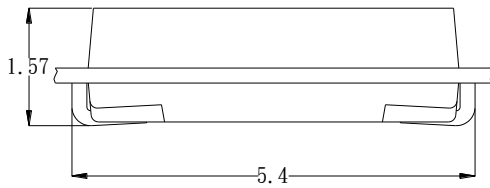
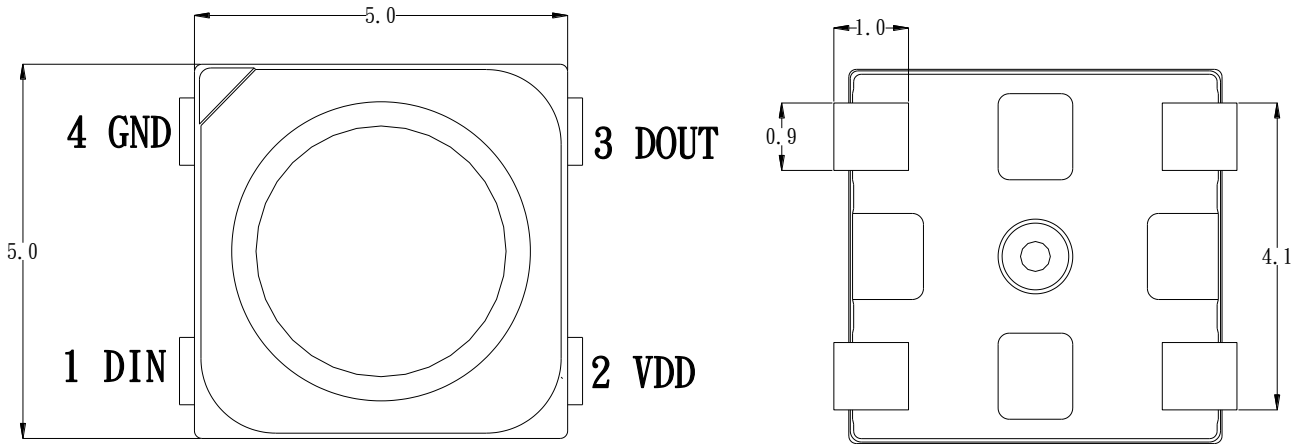

Recommend pad layout

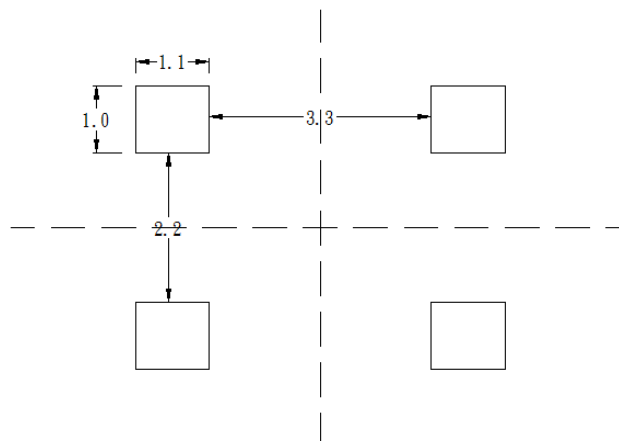

- § All dimensions are in millimeters.
- § Tolerance is ± 0.1 mm unless other specified
- § Specifications are subject to change without notice

■ PIN Configuration

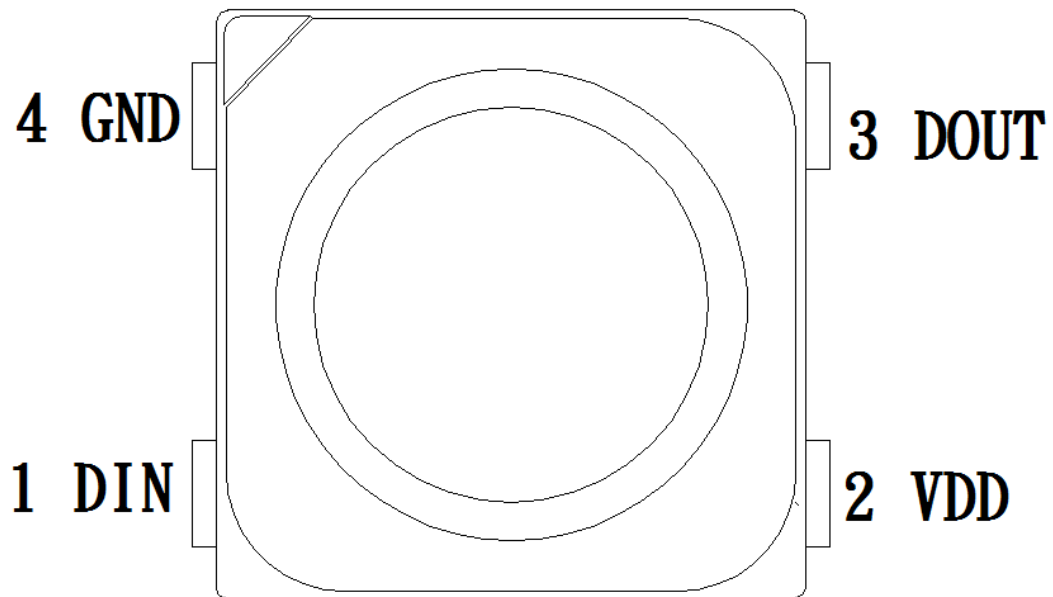

No.	Symbol	Function description
1	DIN	Control data signal input
2	VDD	Power supply LED
3	DOUT	Control data signal output
4	GND	Ground

■ Reflow Profile

1. IR reflow soldering Profile for Lead Free solder

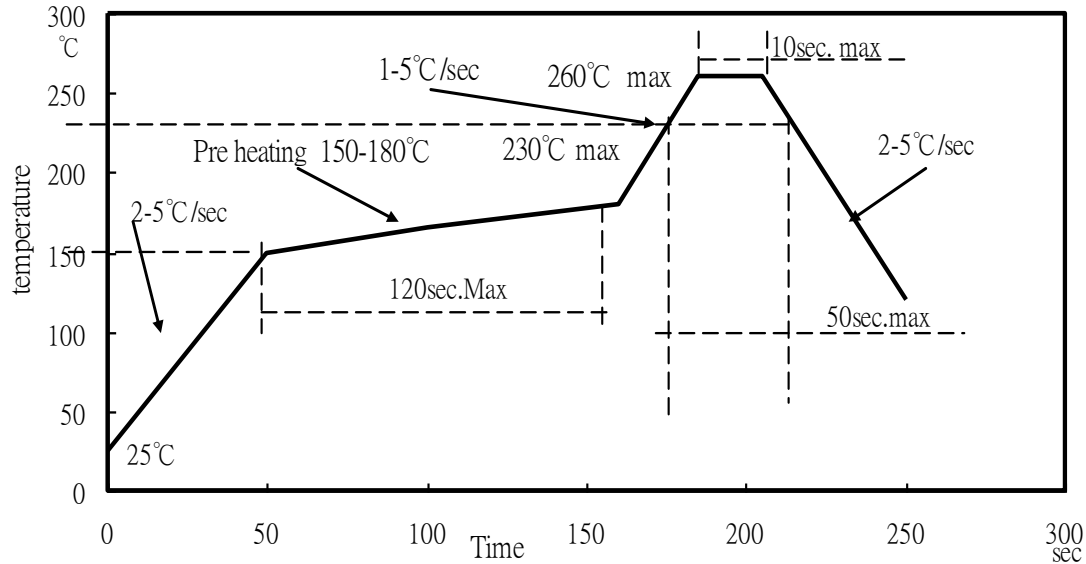

Notes:

1. We recommend the reflow temperature 240°C ($\pm 5^\circ\text{C}$). the maximum soldering temperature should be limited to 260°C.
2. Don't cause stress to the silicone resin while it is exposed to high temperature.
3. Number of reflow process shall not be more than 1 time.
4. Suggest hand soldering temperature of 320°C ($\pm 5^\circ\text{C}$) and shall not be more than 3 seconds.

■ Test Circuit and Handling Precautions

1. Typical application circuit

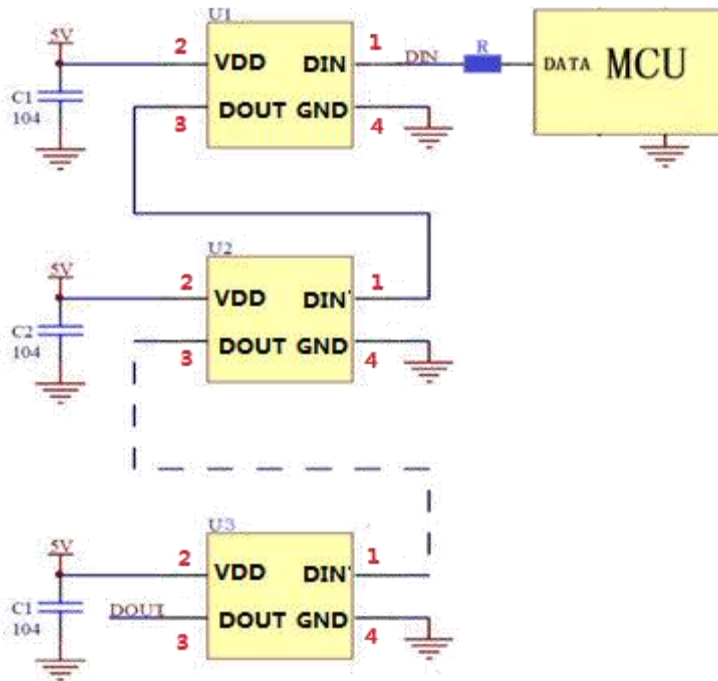

2. Handling precautions

2.1. Over-current-proof

Customer must apply resistors for protection; otherwise slight voltage shift will cause big current change (Burn out will happen).

2.2. Storage

1). It is recommended to store the products in the following conditions:

Humidity: 60% R.H. Max.

Temperature: 5°C ~ 30°C (41°F ~ 86°F)

2). Shelf life in sealed bag: 12 month at < 5°C ~ 30°C and < 60% R.H. after the package is Opened, the products should be used within 24 hours or they should be keeping to stored at $\leq 20\%$ R.H. with zip-lock sealed.

2.3. Baking

Suggest packing opened after 24 hours, before use baking products, conditions as follows:

1). 60±3°C X 6hrs and < 5% RH, for reel

2). 125±3°C X 2hrs, for single LED

It shall be normal to see slight color fading of carrier (light yellow) after baking in process.

■ Packing

● Packaging specifications

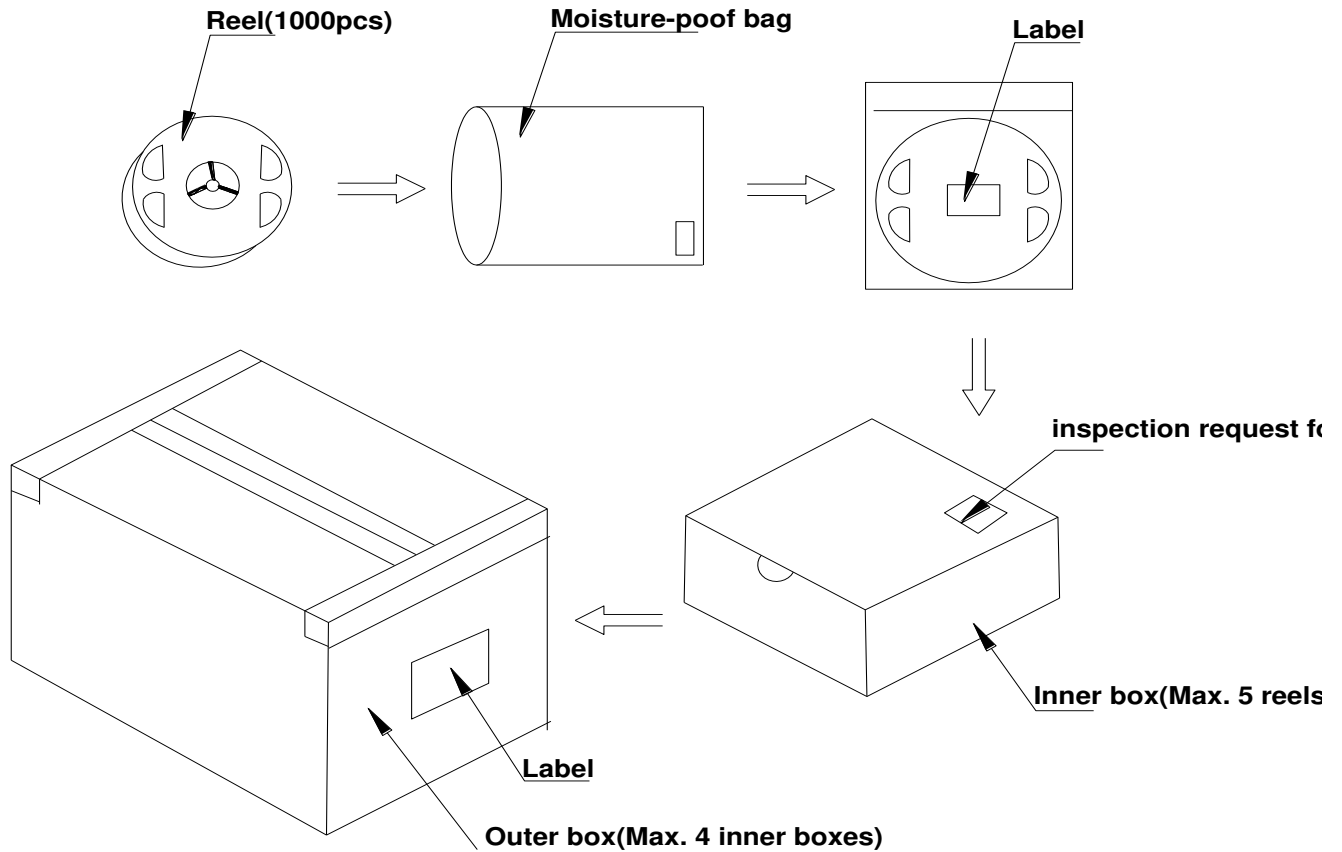

Notes:

Reeled product (max.1000) is packed in a sealed moisture-proof bag. Five bags are packed in an inner box (size: about 260X230X 100mm) and four inner boxes are in an outer box (size: about 480 X 275X 215mm). On the label of moisture-proof bag, there should be the information of Part No., Lot No. and quantity number; also the total quantity number should be on inspection request form on outer box.

■ Precautions

1. Abnormal situation caused by improper setting of collet

To choose the right collet is the key issue in improving the product's quality. LED is different from other electronic components, which is not only about electrical output but also for optical output. This characteristic made LED more fragile in the process of SMT. If the collet's lowering down height is not well set, it will bring damage to the gold wire at the time of collet's picking up and loading which will cause the LED fail to light up, light up now and then or other quality problems

2. How to choose the collet

During SMT, please choose the collet that has larger outer diameter than the lighting area of lens, in case that improper position of collet will damage the gold wire inside the LED. Different collets fit for different products, please refer to the following pictures cross out

Outer diameter of collet should be larger than the lighting area

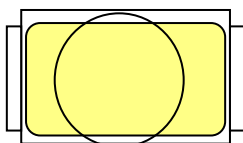

Picture 1(✓)

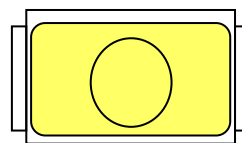

Picture 2(X)

3. Other points for attention

- A. No pressure should be exerted to the epoxy shell of the SMD under high temperature.
- B. Do not scratch or wipe the lens since the lens and gold wire inside are rather fragile and cross out easy to break.
- C. LED should be used as soon as possible when being taken out of the original package, and should be stored in anti-moisture and anti-ESD package.

4. This usage and handling instruction is only for your reference.

■ Test Items and Results of Reliability-----

Test Item	Test Conditions	Duration/ Cycle	Ac/Re	Number of Damage	Reference
Normal TemperatureLife	T _a =23°C(±5°C) I _F =12mA	1008 hrs	0/1	0/22	JESD22 A-108
High TemperatureLife	T _a =85°C(±5°C) I _F =12mA	1008 hrs	0/1	0/22	JESD22 A-108
High Humidity Heat Life	T _a =85°C(±5°C) RH=85% I _F =12mA	1008 hrs	0/1	0/22	JESD22 A-108
Thermal shock	-45°C/30min~105°C /30min (±5°C)	1008 hrs	0/1	0/22	JESD22 A-104
Electrostatic Discharge (ESD)Test	According to the SPEC	3 cycles	0/1	0/22	AEC Q101-001
Low Temperature Storage	T _a =-40°C	1008 hrs	0/1	0/22	JESD22-A103D
High Temperature Storage	T _a =105°C	1008 hrs	0/1	0/22	JESD22-A103D

***Criteria for Judging**

Item	Symbol	Condition	Criteria for Judgment of Pass	
			Min	Max
Forward Voltage	V _F	I _F =12mA	-	USL* ¹ ×1.1
Reverse Current	I _R	V _R = 5V	-	10μA
Luminous Intensity	I _v	I _F =12mA	LSL* ² ×0.7	-

[Note]USL*¹: Upper Specification Level

LSL*²: Lower Specification Level