

# BGF148

7 line ESD and EMI interface protection device

BGF148

## Datasheet

Revision 1.9.2, 2014-04-02  
Final

**Edition 2014-04-02**

**Published by**

**Infineon Technologies AG**

**81726 Munich, Germany**

**© 2014 Infineon Technologies AG**

**All Rights Reserved.**

### **Information**

For further information on technology, delivery terms and conditions and prices, please contact the nearest Infineon Technologies Office ([www.infineon.com](http://www.infineon.com))

### **Warnings**

Due to technical requirements, components may contain dangerous substances. For information on the types in question, please contact the nearest Infineon Technologies Office.

Infineon Technologies components may be used in life-support devices or systems only with the express written approval of Infineon Technologies, if a failure of such components can reasonably be expected to cause the failure of that life-support device or system or to affect the safety or effectiveness of that device or system. Life support devices or systems are intended to be implanted in the human body or to support and/or maintain and sustain and/or protect human life. If they fail, it is reasonable to assume that the health of the user or other persons may be endangered.

**Revision History Rev. 1.9.1, 2014-01-17**

Page or Item	Subjects (major changes since previous revision)
--------------	--

**Revision 1.9.2, 2014-04-02**

5	Table 2-1) updated

**Trademarks of Infineon Technologies AG**

AURIX™, C166™, CanPAK™, CIPOS™, CIPURSE™, EconoPACK™, CoolMOS™, CoolSET™, CORECONTROL™, CROSSAVE™, DAVE™, DI-POL™, EasyPIM™, EconoBRIDGE™, EconoDUAL™, EconoPIM™, EconoPACK™, EiceDRIVER™, eupec™, FCOS™, HITFET™, HybridPACK™, I<sup>2</sup>RF™, ISOFACE™, IsoPACK™, MIPAQ™, ModSTACK™, my-d™, NovalithIC™, OptiMOS™, ORIGA™, POWERCODE™; PRIMARION™, PrimePACK™, PrimeSTACK™, PRO-SIL™, PROFET™, RASIC™, ReverSave™, SatRIC™, SIEGET™, SINDRION™, SIPMOS™, SmartLEWIS™, SOLID FLASH™, TEMPFET™, thinQ!™, TRENCHSTOP™, TriCore™.

**Other Trademarks**

Advance Design System™ (ADS) of Agilent Technologies, AMBA™, ARM™, MULTI-ICE™, KEIL™, PRIMECELL™, REALVIEW™, THUMB™, μVision™ of ARM Limited, UK. AUTOSAR™ is licensed by AUTOSAR development partnership. Bluetooth™ of Bluetooth SIG Inc. CAT-iq™ of DECT Forum. COLOSSUS™, FirstGPS™ of Trimble Navigation Ltd. EMV™ of EMVCo, LLC (Visa Holdings Inc.). EPCOS™ of Epcos AG. FLEXGO™ of Microsoft Corporation. FlexRay™ is licensed by FlexRay Consortium. HYPERTERMINAL™ of Hilgraeve Incorporated. IEC™ of Commission Electrotechnique Internationale. IrDA™ of Infrared Data Association Corporation. ISO™ of INTERNATIONAL ORGANIZATION FOR STANDARDIZATION. MATLAB™ of MathWorks, Inc. MAXIM™ of Maxim Integrated Products, Inc. MICROTEC™, NUCLEUS™ of Mentor Graphics Corporation. MIPI™ of MIPI Alliance, Inc. MIPS™ of MIPS Technologies, Inc., USA. muRata™ of MURATA MANUFACTURING CO., MICROWAVE OFFICE™ (MWO) of Applied Wave Research Inc., OmniVision™ of OmniVision Technologies, Inc. Openwave™ Openwave Systems Inc. RED HAT™ Red Hat, Inc. RFMD™ RF Micro Devices, Inc. SIRIUS™ of Sirius Satellite Radio Inc. SOLARIS™ of Sun Microsystems, Inc. SPANSION™ of Spansion LLC Ltd. Symbian™ of Symbian Software Limited. TAIYO YUDEN™ of Taiyo Yuden Co. TEAKLITE™ of CEVA, Inc. TEKTRONIX™ of Tektronix Inc. TOKO™ of TOKO KABUSHIKI KAISHA TA. UNIX™ of X/Open Company Limited. VERILOG™, PALLADIUM™ of Cadence Design Systems, Inc. VLYNQ™ of Texas Instruments Incorporated. VXWORKS™, WIND RIVER™ of WIND RIVER SYSTEMS, INC. ZETEX™ of Diodes Zetex Limited.

Last Trademarks Update 2011-11-11

## 1 7 line ESD and EMI interface protection device

### 1.1 Features

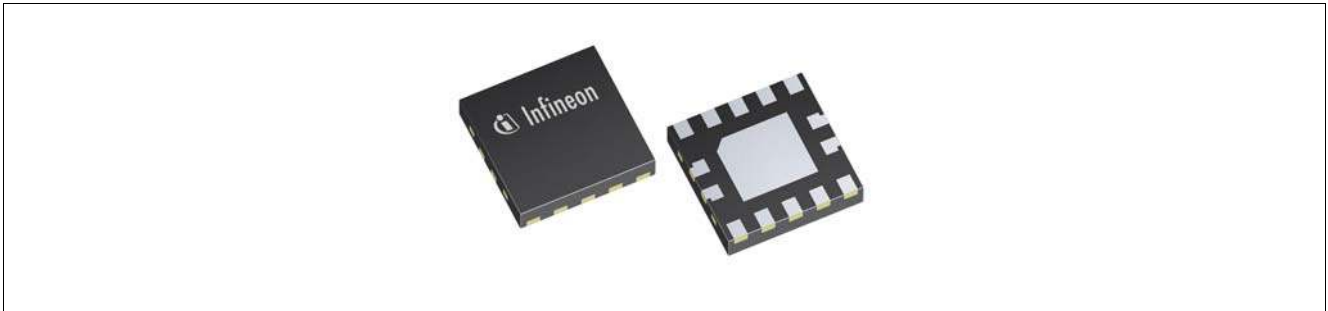

- 7 line bidirectional ESD protection
- ESD protection according to IEC61000-4-2 for  $\pm 15$  kV contact discharge on all external IOs
- ESD protection according to IEC61000-4-2 for  $\pm 8$  kV contact discharge on all internal IOs
- 6 line pi-type EMI filter for superior EMI filtering and very low cross-talk due to low parasitics
- Suitable for high speed applications due to low line capacitance of typical 1.2 pF
- Very low voltage dependency of line capacitance
- Very low leakage currents
- Application requires very small PCB area using an optimized I/O arrangement
- Small sized Plastic Package with 400  $\mu\text{m}$  pitch
- Pb-free (RoHS compliant) and halogen free package
- Complies with following standards: SD Card Specification V4.1 including UHS104 mode



### 1.2 Application

- High-Speed Mini-/Micro- SD Card ESD protection and EMI filter
- SD3.0 card Interface (Mini, Micro), down compatible to SD2.0 and lower
  - feature phones, smart phones, tablets, digital still cameras, digital video cameras, computers and other devices using SD card interfaces

### 1.3 Product Description

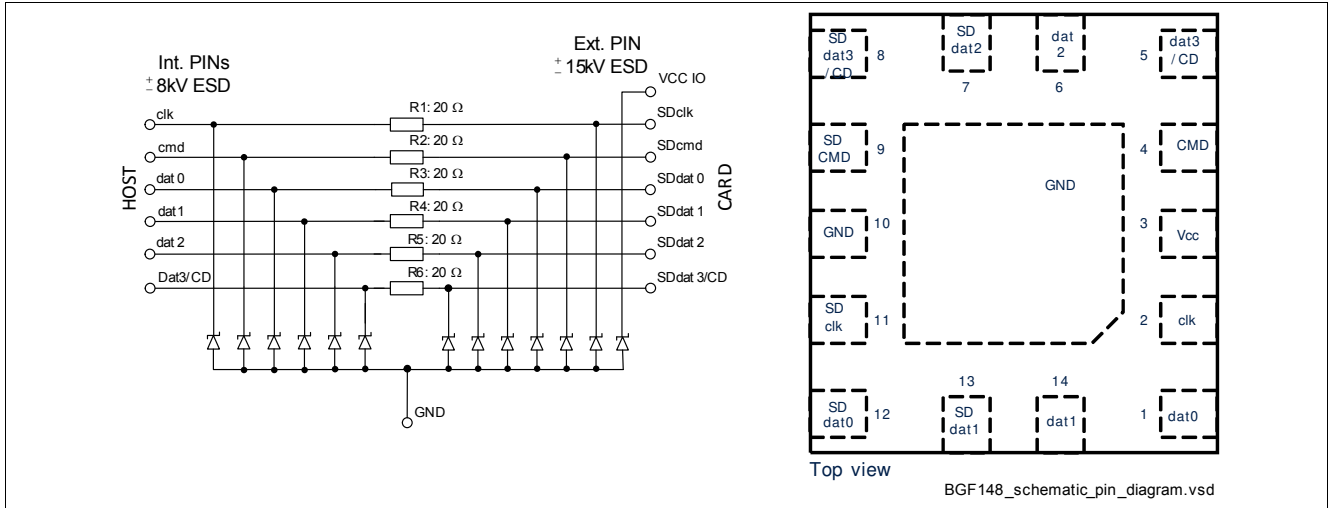

Figure 1-1 Schematic

Type	Package	Marking	Chip
BGF148	TSNP-14-2	48	N0756

## 2 Electrical Characteristics

### 2.1 Maximum Ratings

Table 2-1 Maximum Ratings at  $T_A = 25\text{ }^\circ\text{C}$ , unless otherwise specified

Parameter	Symbol	Values			Unit	Note / Test Condition
		Min.	Typ.	Max.		
Voltage at all pins to GND	$V_F$	0	-	5.5	V	
Operating temperature range	$T_{OP}$	-40	-	+85	$^\circ\text{C}$	
Storage temperature range	$T_{STG}$	-65	-	+150	$^\circ\text{C}$	
ESD contact discharge <sup>1)</sup>	$V_{ESD}$		-		kV	
External IOs		-15		15		
Internal IOs		-8		8		

1)  $V_{ESD}$  according to IEC61000-4-2

**Attention: Stresses above the max. values listed here may cause permanent damage to the device. Exposure to absolute maximum rating conditions for extended periods may affect device reliability. Maximum ratings are absolute ratings; exceeding only one of these values may cause irreversible damage to the integrated circuit.**

## 2.2 Electrical Characteristics

**Table 2-2 DC Characteristics at  $T_A = 25\text{ °C}$ , unless otherwise specified**

Parameter	Symbol	Values			Unit	Note / Test Condition
		Min.	Typ.	Max.		
Resistor $R_1...R_6$	$R_1...R_6$	18	20	22	$\Omega$	
Reverse current of ESD diodes	$I_R$	-	5	100	nA	$V_R = 5.5\text{ V}$
Breakdown voltage of ESD diodes	$V_{BR}$	-	6.5	-	V	$I_{BR} = 1\text{ mA}$

**Table 2-3 RF Characteristics at  $T_A = 25\text{ °C}$ , unless otherwise specified**

Parameter	Symbol	Values			Unit	Note / Test Condition
		Min.	Typ.	Max.		
Line capacitance (Capacitance of each line to GND)	$C_L$		1.2		pF	$V_R = 0\text{ V}, f = 1\text{ MHz}$

**Table 2-4 ESD Characteristics at  $T_A = 25\text{ °C}$ , unless otherwise specified**

Parameter	Symbol	Values			Unit	Note / Test Condition
		Min.	Typ.	Max.		
Clamping voltage <sup>1)2)</sup>	$V_{CL}$	-	8.5	-		$I_{TLP} = 1\text{ A}$
		-	9	-		$I_{TLP} = 16\text{ A}$
Dynamic resistance <sup>1)2)</sup>	$R_{DYN}$	-	0.03	-	$\Omega$	

1) Pulse at external pins, measurements at related internal pins

2) ANSI / ESDSTM5.5.1-Electrostatic Discharge Sensitivity Testing using Transmission Line Pulse (TLP) Model. TLP conditions:  $Z_0 = 50\ \Omega$ ,  $t_p = 100\text{ ns}$ ,  $t_r = 0.6\text{ ns}$ ,  $I_{TLP}$  and  $V_{TLP}$  average window:  $t_1 = 30\text{ ns}$  to  $t_2 = 60\text{ ns}$ , extraction of dynamic resistance using squares fit to TLP characteristics between  $I_{TLP1} = 2\text{ A}$  and  $I_{TLP2} = 15\text{ A}$ . Please refer to Application Note AN210[1]

### 3 Typical Characteristics

Curves specified at  $T_A = 25\text{ }^\circ\text{C}$ , unless otherwise specified

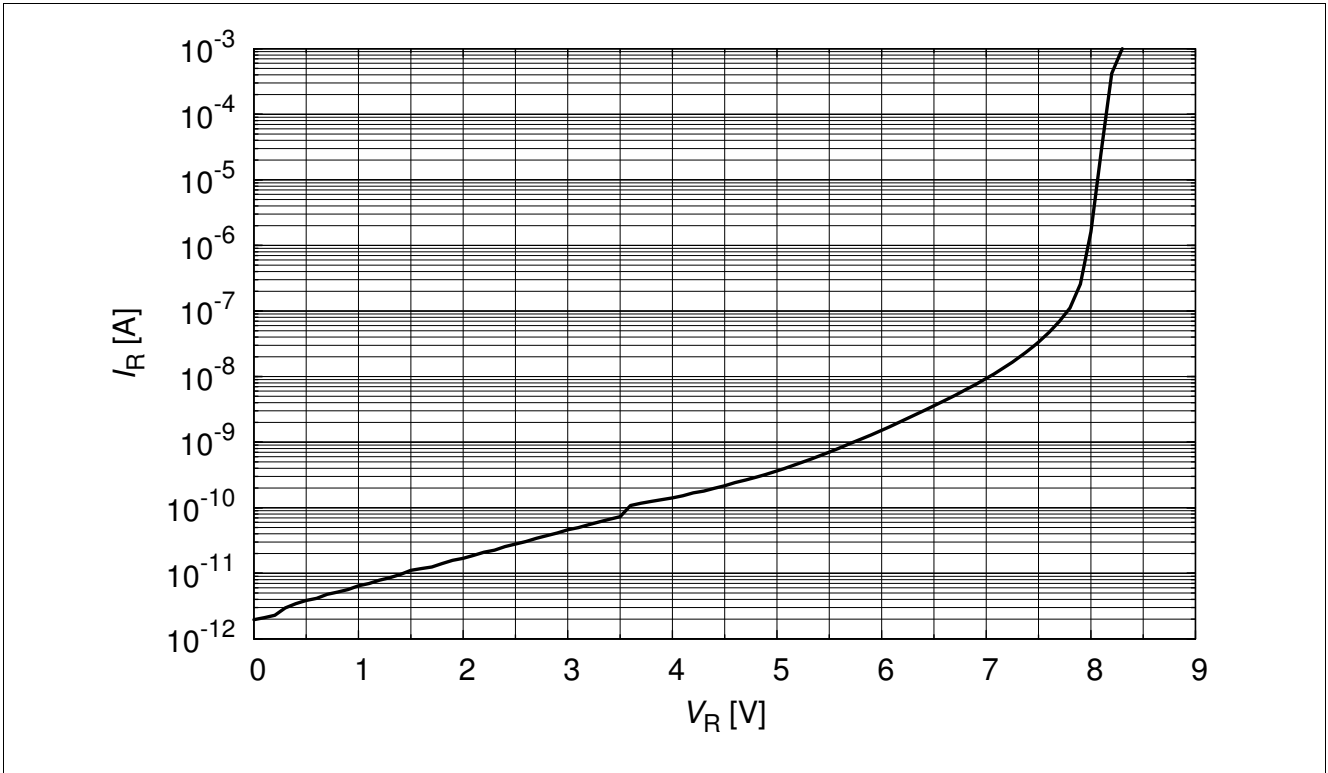

Figure 3-1 Reverse current:  $I_R = f(V_R)$

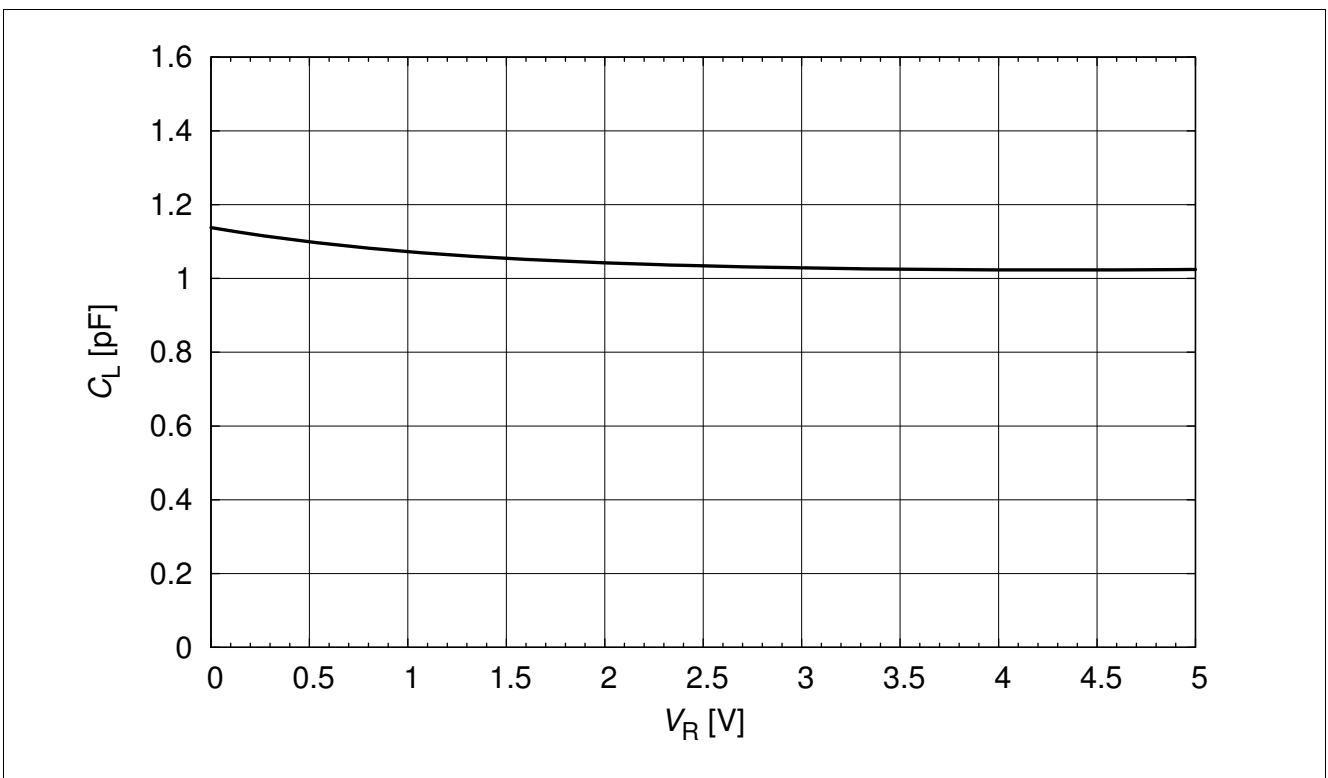

Figure 3-2 Line capacitance of line A1 - A4:  $C_L = f(V_R), f = 1\text{ MHz}$

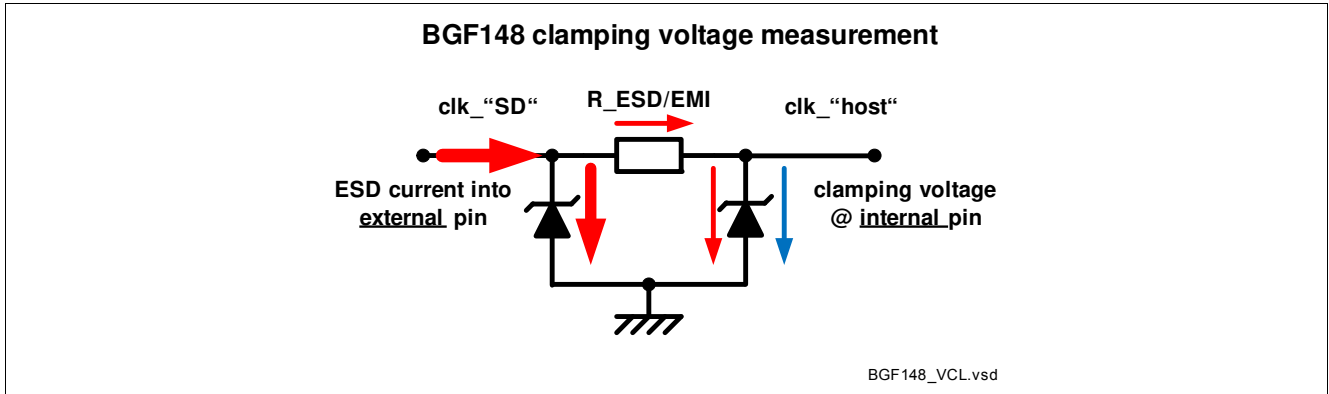

Figure 3-3 Measurement setup for clamping voltage

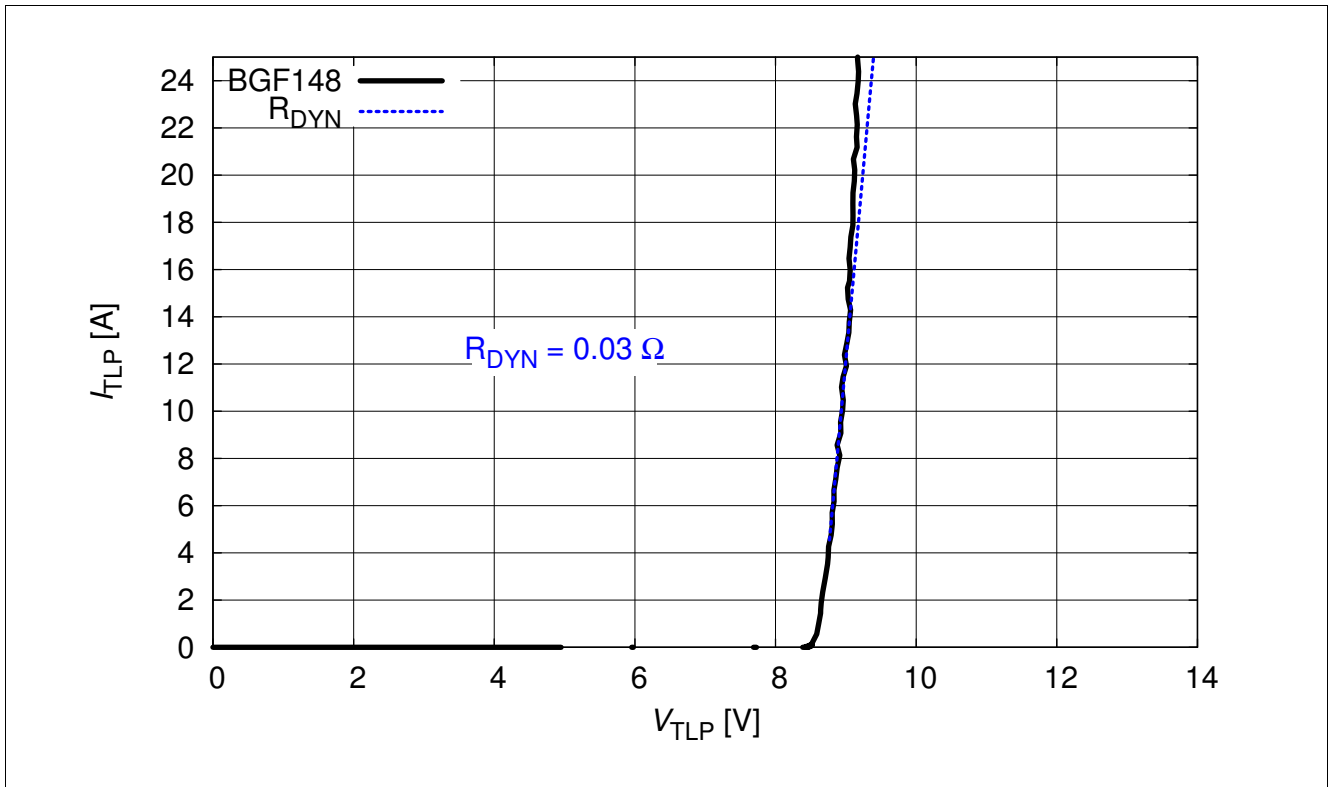

Figure 3-4 Clamping voltage (TLP):  $I_{TLP} = f(V_{TLP})$  according ANSI/ESDSTM5.5.1-Electrostatic Discharge Sensitivity Testing using Transmission Line Pulse (TLP) Model. TLP conditions:  $Z_0 = 50 \Omega$ ,  $t_p = 100 \text{ ns}$ ,  $t_r = 0.6 \text{ ns}$ ,  $I_{TLP}$  and  $V_{TLP}$  average window:  $t_1 = 30 \text{ ns}$  to  $t_2 = 60 \text{ ns}$ , extraction of dynamic resistance using squares fit to TLP characteristics between  $I_{TLP1} = 2 \text{ A}$  and  $I_{TLP2} = 15 \text{ A}$ . Please refer to Application Note AN210[1]



## 4 Application Hints

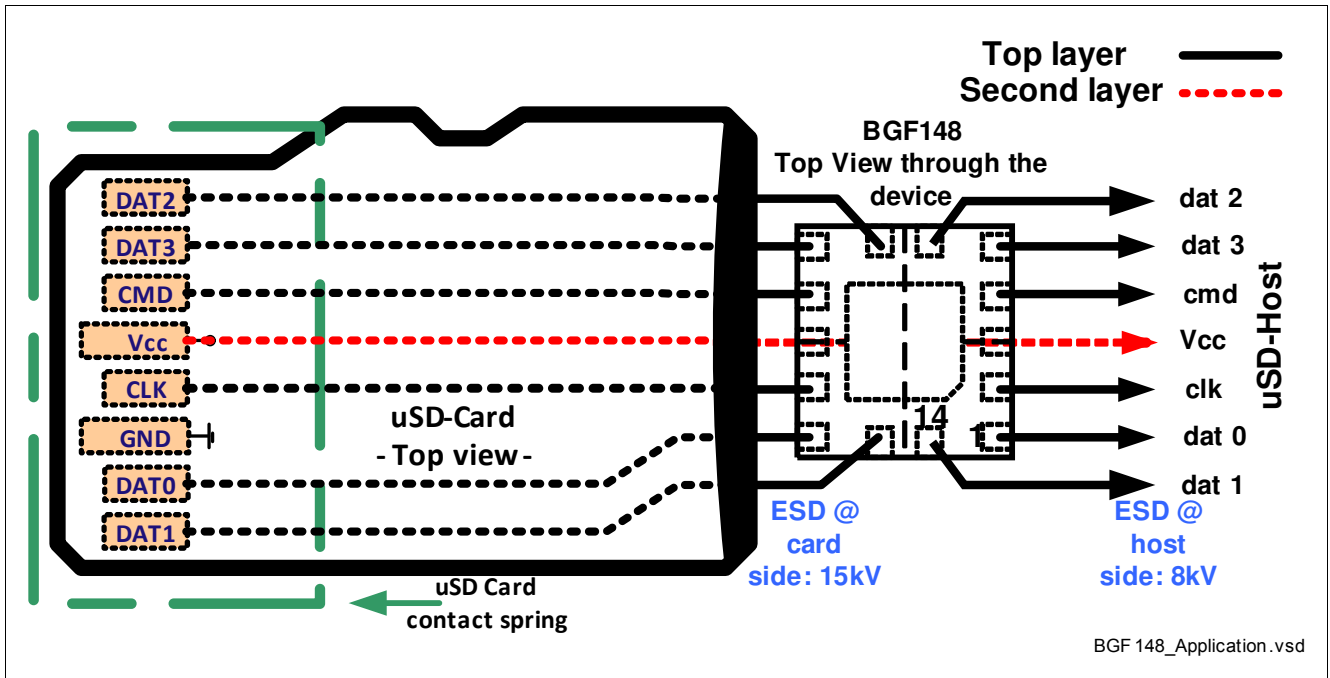

Figure 4-1 Application

## 5 Package

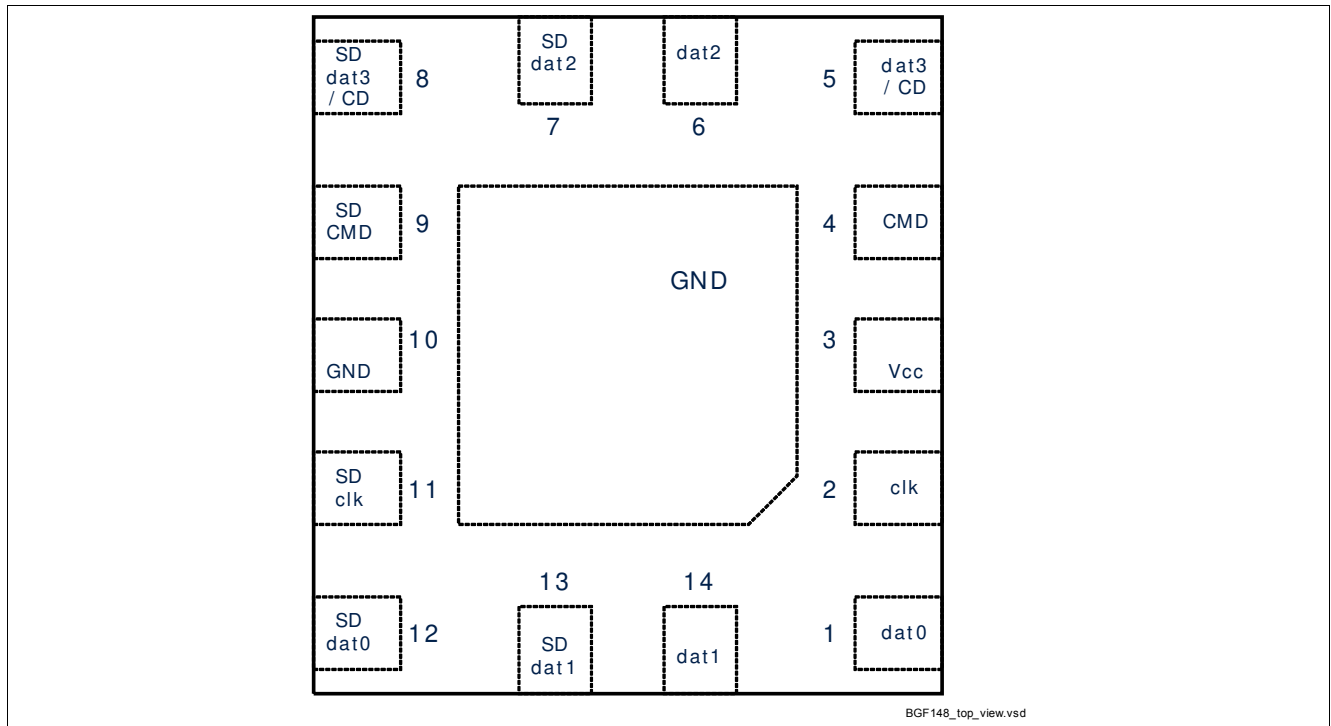

Figure 5-1 Top view through the device

Table 5-1 Pin and Function

Pin #	Function		ESD (IEC61000-4-2, contact discharge)
1	Dat0	Int. PIN	±8 kV
2	Clk	Int. PIN	±8 kV
3	VccIO	Ext. PIN	±15 kV
4	CDM	Int. PIN	±8 kV
5	Dat3/CD	Int. PIN	±8 kV
6	Dat2	Int. PIN	±8 kV
7	SDdat2	Ext. PIN	±15 kV
8	SDdat3/CD	Ext. PIN	±15 kV
9	SDCMD	Ext. PIN	±15 kV
10	GND		
11	SDclk	Ext. PIN	±15 kV
12	SDdat0	Ext. PIN	±15 kV
13	SDdat1	Ext. PIN	±15 kV
14	Dat1	Int. PIN	±8 kV
Center	GND		

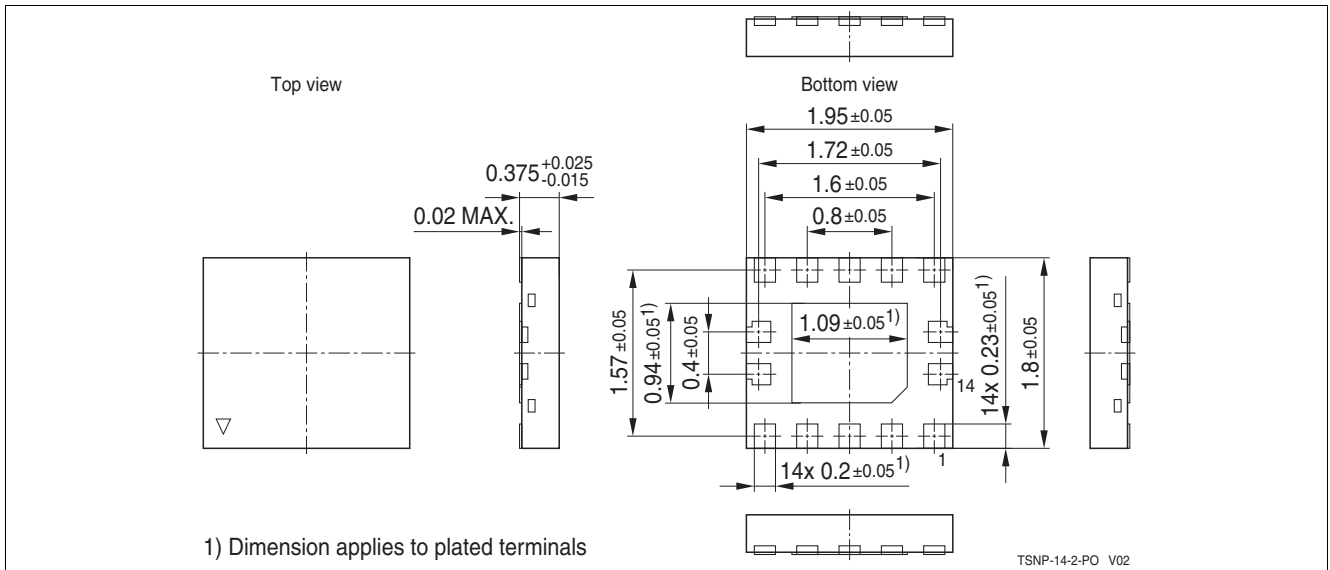

Figure 5-2 Package outline for TSNP-14-2 (dimension in mm)

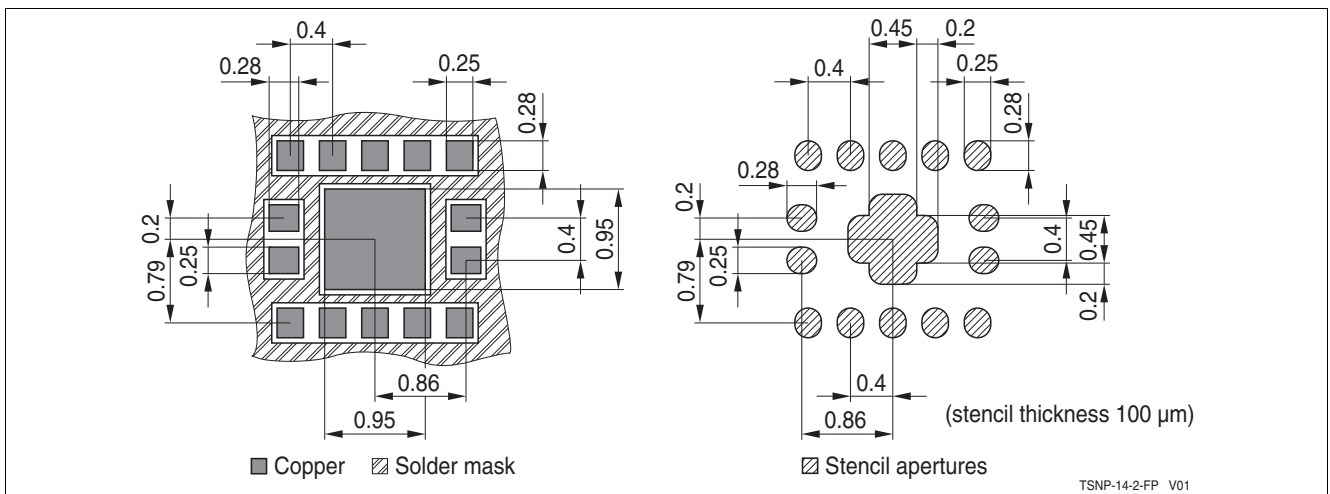

Figure 5-3 Footprint and stencil recommendation for TSNP-14-2

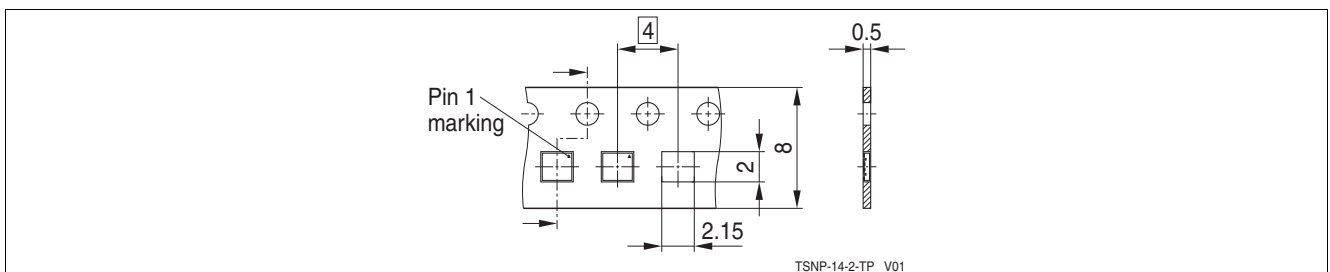

Figure 5-4 Tape (dimension in mm) for TSNP-14-2

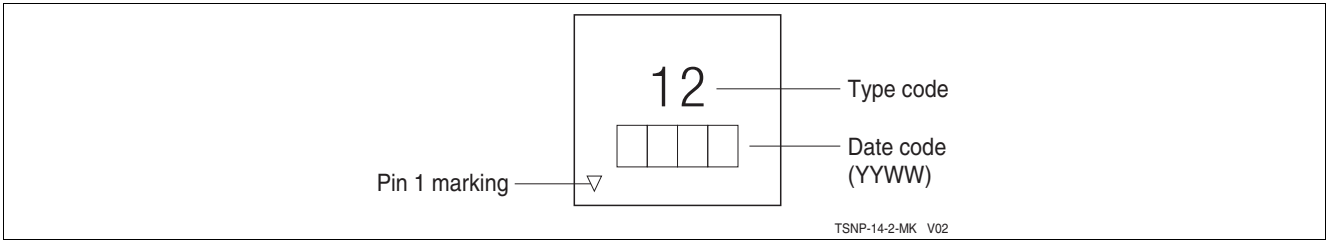

Figure 5-5 Marking example

**References**

- [1] Infineon AG - **Application Note AN210: Effective ESD Protection design at System Level Using VF-TLP Characterization Methodology**

[www.infineon.com](http://www.infineon.com)

Published by Infineon Technologies AG