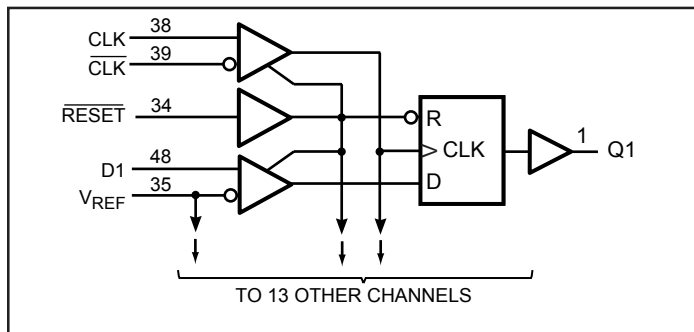

**14-Bit Registered Buffer**
**Product Features**

- PI74 SSTVF16857 is designed for low-voltage operation, 2.5V for PC1600~PC2700; 2.6V for PC3200
- Supports SSTL\_2 Class I output specifications
- SSTL\_2 Input and Output Levels
- Designed for DDR Memory
- Flow-Through Architecture
- Packaging Options (Pb-free available):
  - 48-pin 240 mil wide plastic TSSOP (A)
  - 48-pin 173 mil wide plastic TVSOP (K)

**Logic Block Diagram**

**Product Pin Description**

Pin Name	Description
$\overline{\text{RESET}}$	Reset (Active Low)
CLK	Clock Input
CLK	Clock Input
D	Data Input
Q	Data Output
GND	Ground
VDD	Core Supply Voltage
VDDQ	Output Supply Voltage
VREF	Input Reference Voltage

**Truth Table<sup>(1)</sup>**

Inputs				Outputs
RESET	CLK	CLK	D	Q
L	X	X	X	L
H	↑	↓	H	H
H	↑	↓	L	L
H	L or H	L or H	X	Q <sub>0</sub> <sup>(2)</sup>

**Notes:**

1. H = High Signal Level  
L = Low Signal Level  
↑ = Transition LOW-to-HIGH  
↓ = Transition HIGH-to-LOW  
X = Irrelevant
2. Output level before the indicated steady state input conditions were established.

**Product Description**

Pericom Semiconductor's PI74SSTVF16857 series of logic circuits are produced using the Company's advanced sub-micron CMOS technology, achieving industry leading speed.

The 14-bit PI74SSTVF16857 universal bus driver is designed for 2.5V to 2.6V V<sub>DD</sub> operation and SSTL\_2 I/O Levels except for the  $\overline{\text{RESET}}$  input which is LVCMOS.

Data flow from D to Q is controlled by the differential clock, CLK,  $\overline{\text{CLK}}$  and  $\overline{\text{RESET}}$ . Data is triggered on the positive edge of CLK.  $\overline{\text{CLK}}$  must be used to maintain noise margins.

$\overline{\text{RESET}}$  must be supported with LVCMOS levels as V<sub>REF</sub> may not be stable during power-up. RESET is asynchronous and is intended for power-up only and when low assures that all of the registers reset to the Low State, Q outputs are low, and all input receivers, data and clock, are switched off.

Pericom's PI74SSTVF16857 is characterized for operation from 0° to 70°C.

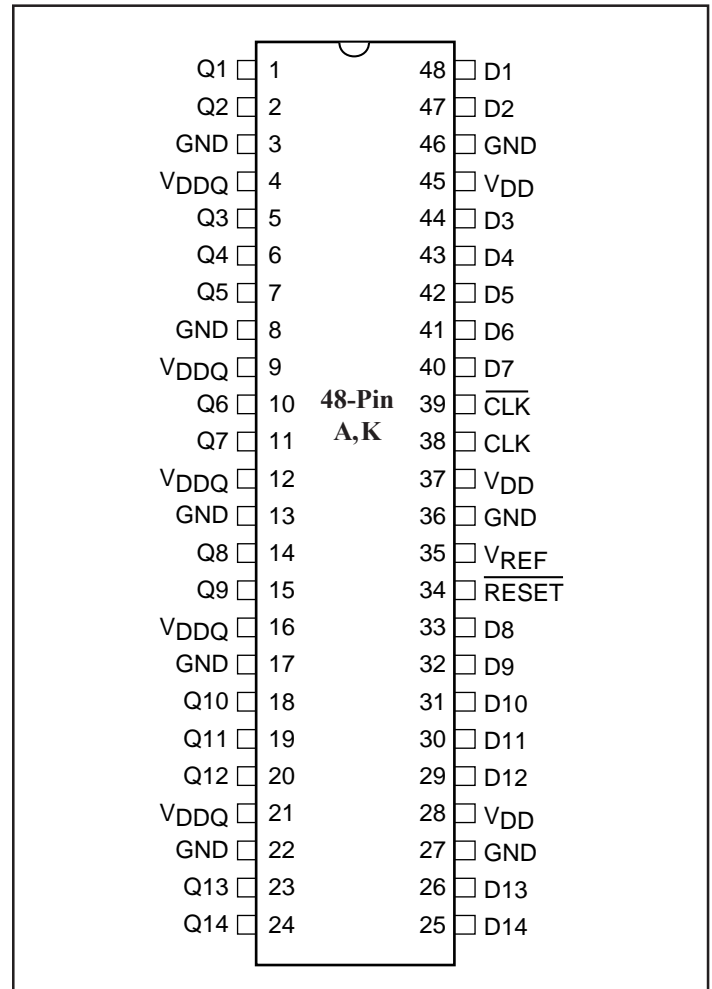
**Product Pin Configuration**

### Maximum Ratings

(Above which the useful life may be impaired. For user guidelines, not tested.)

Parameter	Symbol	Ratings	Units	
Storage Temperature	Tstg	-65 to 150	°C	
Supply Voltage	V <sub>DD</sub> or V <sub>DDQ</sub>	- 0.5 to 3.6	V	
Input Voltage <sup>(1)</sup>	V <sub>I</sub>	- 0.5 to V <sub>DD</sub> + 0.5		
Output Voltage <sup>(1,2)</sup>	V <sub>O</sub>	- 0.5 to V <sub>DDQ</sub> + 0.5		
Input Clamp Current	I <sub>IK</sub> , V <sub>I</sub> < 0	- 50	mA	
Output Clamp Current	I <sub>OK</sub> , V <sub>O</sub> < 0	±50		
Continuous Output Current	I <sub>O</sub> , V <sub>O</sub> = 0 to V <sub>DDQ</sub>	±50		
V <sub>DD</sub> , V <sub>DDQ</sub> , or GND current/pin	I <sub>DD</sub> , I <sub>DDQ</sub> or GND	±100		
Package Thermal Impedance	A-Package	θ <sub>JA</sub>	70	°C/W
	K-Package		58	

#### Notes:

Stresses greater than those listed under MAXIMUM RATINGS may cause permanent damage to the device. This is a stress rating only and functional operation of the device at these or any other conditions above those indicated in the operational sections of this specification is not implied. Exposure to absolute maximum rating conditions for extended periods may affect reliability.

1. The input and output negative voltage ratings may be excluded if the input and output clamp ratings are observed.
2. This current will flow only when the output is in the high state level V<sub>O</sub> > V<sub>DDQ</sub>.
3. The package thermal impedance is calculated in accordance with JESD 51-7.

**Recommended Operating Conditions**

Parameters	Description		Min.	Nom.	Max.	Units
$V_{DD}/V_{DDQ}$	Core/Output Supply Voltage	PC1600 PC2700	2.3	2.5	2.7	V
		PC3200	2.5	2.6	2.7	
$V_{REF}$	Reference Voltage $V_{REF} = 0.5X$ $V_{DDQ}$	PC1600 PC2700	1.15	1.25	1.35	
		PC3200	1.25	1.3	1.35	
$V_{IH}$	AC input High Voltage	Data Inputs	$V_{REF} + 0.31$			
$V_{IL}$	AC input Low Voltage	Data Inputs			$V_{REF} - 0.31$	
$V_I$	Input Voltage		0	$V_{REF}$	$V_{DD}$	
$V_{IH}$	DC Input High Voltage	Data Inputs	$V_{REF} + 0.15$			
$V_{IL}$	DC Input Low Voltage				$V_{REF} - 0.15$	
$V_{IH}$	Input High Voltage	$\overline{RESET}$	1.7			
$V_{IL}$	Input Low Voltage				0.7	
$V_{ICR}$	Common-Mode Input Voltage Range	CLK, $\overline{CLK}$	0.97		1.53	
$V_{ID}$	Peak-to-Peak Input Voltage			0.36		$V_{DDQ} + 0.6$
$I_{OH}$	High-Level Output Current				-16	mA
$I_{OL}$	Low-Level Output Current				16	
$T_A$	Operating Free-Air Temperature		0		70	°C

**DC Electrical Characteristics for PC1600~PC2700**

 (Over the Operating Range,  $T_A = 0^\circ\text{C}$  to  $+70^\circ\text{C}$ ,  $V_{DD} = 2.5\text{V} \pm 200\text{mV}$ ,  $V_{DDQ} = 2.5\text{V} \pm 200\text{mV}$ )

Parameters		Test Conditions	VCC	Min.	Typ. <sup>(1)</sup>	Max.	Units			
$V_{IK}$		$I_I = -18\text{mA}$	2.3V			-1.2	V			
$V_{OH}$		$I_{OH} = -100\mu\text{A}$	2.3V-2.7V	$V_{DD} - 0.2\text{V}$						
		$I_{OH} = -8\text{mA}$	2.3V	1.95						
$V_{OL}$		$I_{OL} = 100\mu\text{A}$	2.3V-2.7V			0.2				
		$I_{OH} = 8\text{mA}$	2.3V			0.35				
$I_I$	All Inputs,	$V_I = V_{DD}$ or GND	2.7V			5	$\mu\text{A}$			
$I_{DD}$	Standby (Static)	$\overline{\text{RESET}} = \text{GND}$	2.7V		28	10				
	Operating Static	$V_I = V_{IH}(\overline{\text{AC}})$ or $V_I(\text{AC})$ , $\overline{\text{RESET}} = V_{DD}$				25	mA			
$I_{DDD}$	Dynamic Operating - Clock only	$\overline{\text{RESET}} = V_{DD}$ $V_I = V_{IH}(\text{AC})$ or $V_{IL}(\text{AC})$ , CK and $\overline{\text{CK}}$ switching 50% duty cycle				$I_O = 0$	2.7V	28		$\mu\text{A}/\text{clock MHz}$
	Dynamic Operating - per each data input	$\overline{\text{RESET}} = V_{DD}$ $V_I = V_{IH}(\text{AC})$ or $V_{IL}(\text{AC})$ , CK and $\overline{\text{CK}}$ switching 50% duty cycle. One data input switching at half clock frequency, 50% duty cycle							9	$\mu\text{A}/\text{clock MHz Data}$
$C_I$	Data inputs	$V_I = V_{REF} \pm 310\text{mV}$	2.5V			2.5	pF			
	CK and $\overline{\text{CK}}$	$V_{ICR} = 1.25\text{V}$ , $V_{I(\text{PP})} = 360\text{mV}$				2.5		3.5		
	$\overline{\text{RESET}}$	$V_I = V_{CC}$ or GND				2.5		3.5		

**Notes:**

 4. Typical values are at  $V_{DD} = \text{Nominal } V_{DD}$ ,  $T_A = +25^\circ\text{C}$ .

**DC Electrical Characteristics for PC3200**

 (Over the Operating Range,  $T_A = 0^\circ\text{C}$  to  $+70^\circ\text{C}$ ,  $V_{DD} = 2.6\text{V} \pm 100\text{mV}$ ,  $V_{DDQ} = 2.6\text{V} \pm 100\text{mV}$ )

Parameters		Test Conditions	VCC	Min.	Typ. <sup>(1)</sup>	Max.	Units			
$V_{IK}$		$I_I = -18\text{mA}$	2.5V			-1.2	V			
$V_{OH}$		$I_{OH} = -100\mu\text{A}$	2.5V-2.7V	$V_{DD} - 0.2\text{V}$						
		$I_{OH} = -8\text{mA}$	2.5V	1.95						
$V_{OL}$		$I_{OL} = 100\mu\text{A}$	2.5V-2.7V			0.2				
		$I_{OH} = 8\text{mA}$	2.5V			0.35				
$I_I$	All Inputs,	$V_I = V_{DD}$ or GND	2.7V			5	$\mu\text{A}$			
$I_{DD}$	Standby (Static)	$\overline{\text{RESET}} = \text{GND}$	2.7V			10				
	Operating Static	$V_I = V_{IH(AC)}$ or $V_I(AC)$ , $\overline{\text{RESET}} = V_{DD}$				25	mA			
$I_{DDD}$	Dynamic Operating - Clock only	$\overline{\text{RESET}} = V_{DD}$ $V_I = V_{IH(AC)}$ or $V_{IL(AC)}$ , CK and $\overline{\text{CK}}$ switching 50% duty cycle				$I_O = 0$	2.7V		28	$\mu\text{A}/$ clock MHz
	Dynamic Operating - per each data input	$\overline{\text{RESET}} = V_{DD}$ $V_I = V_{IH(AC)}$ or $V_{IL(AC)}$ , CK and $\overline{\text{CK}}$ switching 50% duty cycle. One data input switching at half clock frequency, 50% duty cycle							9	$\mu\text{A}/$ clock MHz Data
$C_I$	Data inputs	$V_I = V_{REF} \pm 310\text{mV}$	2.6V			2.5	pF			
	CK and $\overline{\text{CK}}$	$V_{ICR} = 1.25\text{V}$ , $V_{I(PP)} = 360\text{mV}$				2.5				
	$\overline{\text{RESET}}$	$V_I = V_{CC}$ or GND				2.5				

**Notes:**

 4. Typical values are at  $V_{DD} = \text{Nominal } V_{DD}$ ,  $T_A = +25^\circ\text{C}$ .

**Timing Requirements** (over recommended operating free-air temperature range, unless otherwise noted)

		V <sub>DD</sub> =2.5V ±0.2V		V <sub>DD</sub> =2.6V ±0.1V		Units
		Min.	Max.	Min.	Max.	
f <sub>clock</sub>	Clock Frequency		270		270	MHz
t <sub>W</sub>	Pulse Duration	2.5		2.5		ns
t <sub>act</sub>	Differential inputs active time <sup>(5)</sup>		22		22	
t <sub>inact</sub>	Output slew rate differential inputs inactive time <sup>(6)</sup>		22		22	
t <sub>SU</sub>	Setup time, fast slew rate <sup>(7, 9)</sup>	Data before CK↑, $\overline{\text{CK}}\downarrow$	0.75		0.75	
	Setup time, slow slew rate <sup>(8, 9)</sup>		0.9		0.9	
t <sub>h</sub>	Hold time, fast slew rate <sup>(7, 9)</sup>	Data before CK↑, $\overline{\text{CK}}\downarrow$	0.75		0.75	
	Hold time, slow slew rate <sup>(8, 9)</sup>		0.9		0.9	

**Notes:**

5. Data inputs must be held low for a minimum time of t<sub>act</sub> min, after  $\overline{\text{RESET}}$  is taken high
6. Data and clock inputs must be held at valid levels (not floating) for a minimum time of t<sub>inact</sub> min, after  $\overline{\text{RESET}}$  is taken low.
7. Data signal input slew rate ≥ 1 V/ns
8. Data signal input slew rate ≥ 0.5V/ns and <1V/ns
9. CLK,  $\overline{\text{CLK}}$  input slew rates are ≥ 1 V/ns.

**Switching Characteristics for PC1600~PC2700**

(over recommended operating free-air temperature range, unless otherwise noted.)  
 (See test circuits and switching waveforms).

Parameter	From (Input)	To (Output)	V <sub>DD</sub> = 2.5V ±0.2V			Units
			Min.	Typ.	Max.	
f <sub>max</sub>			210			MHz
t <sub>pd</sub>	CLK, $\overline{\text{CLK}}$	Q	1.1		2.2	ns
t <sub>phl</sub>	$\overline{\text{RESET}}$	Q			5.0	

**Switching Characteristics for PC3200**

(over recommended operating free-air temperature range, unless otherwise noted.)  
 (See test circuits and switching waveforms).

Parameter	From (Input)	To (Output)	V <sub>DD</sub> = 2.6V ±0.1V			Units
			Min.	Typ.	Max.	
f <sub>max</sub>			210			MHz
t <sub>pd</sub>	CLK, $\overline{\text{CLK}}$	Q	1.1		2.2	ns
t <sub>phl</sub>	$\overline{\text{RESET}}$	Q			5.0	

### Test Circuit and Switching Waveforms

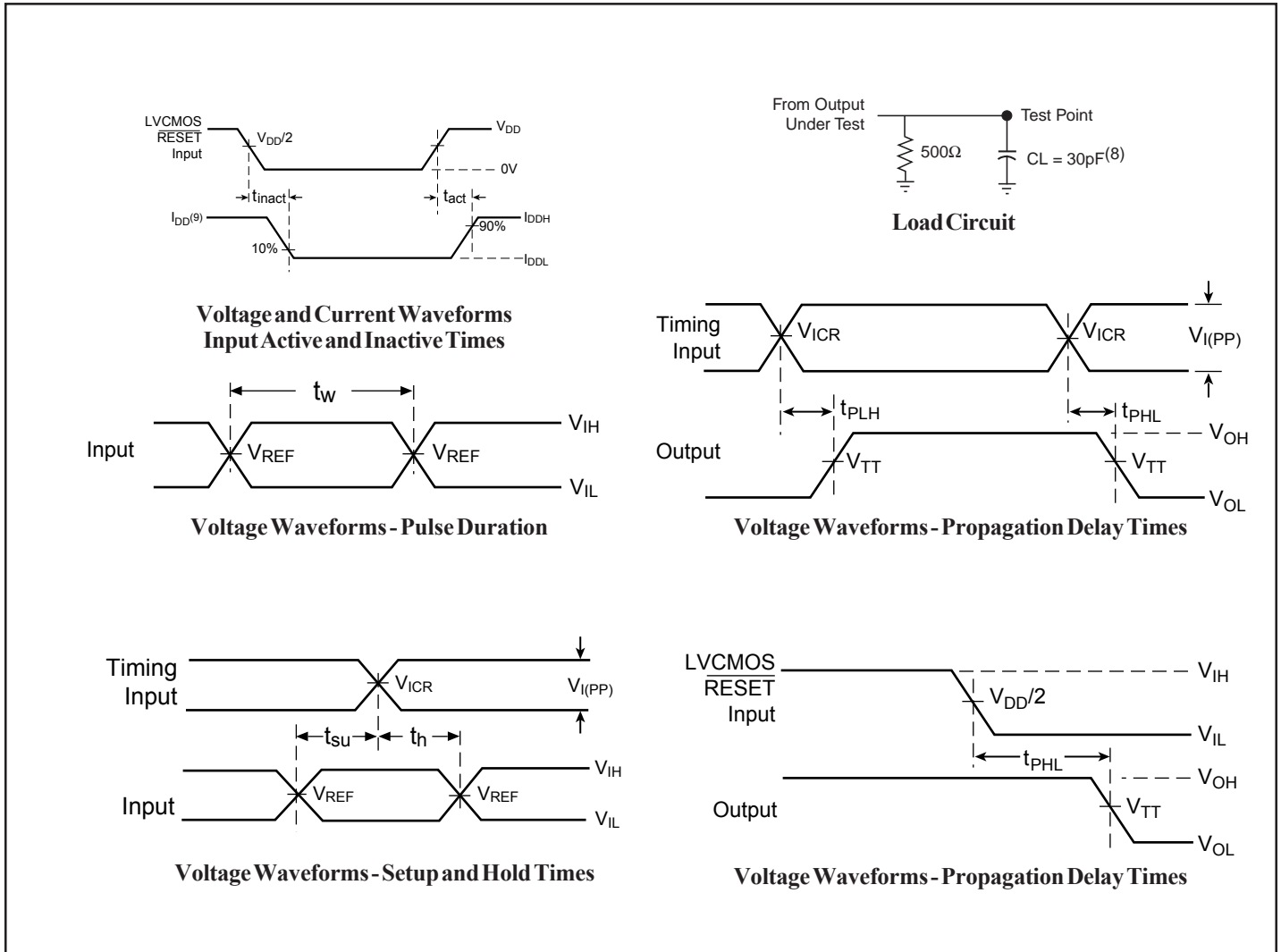

### Parameter Measurement Information

#### Notes:

8.  $C_L$  includes probe and jig capacitance.
9.  $I_{DD}$  tested with clock and data inputs held at  $V_{DD}$  or GND, and  $I_O = 0\text{mA}$ .
10. All input pulses are supplied by generators having the following characteristics:  
PRR  $\leq 10\text{MHz}$ ,  $Z_O = 50\Omega$ . Input slew rate =  $1\text{V/ns} \pm 20\%$  (unless otherwise specified).
11. The outputs are measured one at a time with one transition per measurement.
12.  $V_{TT} = V_{REF} = V_{DDQ}/2$
13.  $V_{IH} = V_{REF} + 310\text{mV}$  (ac voltage levels) for SSTL inputs.  $V_{IH} = V_{DD}$  for LVC MOS input.
14.  $V_{IL} = V_{REF} - 310\text{mV}$  (ac voltage levels) for SSTL inputs.  $V_{IL} = \text{GND}$  for LVC MOS input.
15.  $t_{PLH}$  and  $t_{PHL}$  are the same as  $t_{pd}$ .

48-Pin TSSOP Package (A)

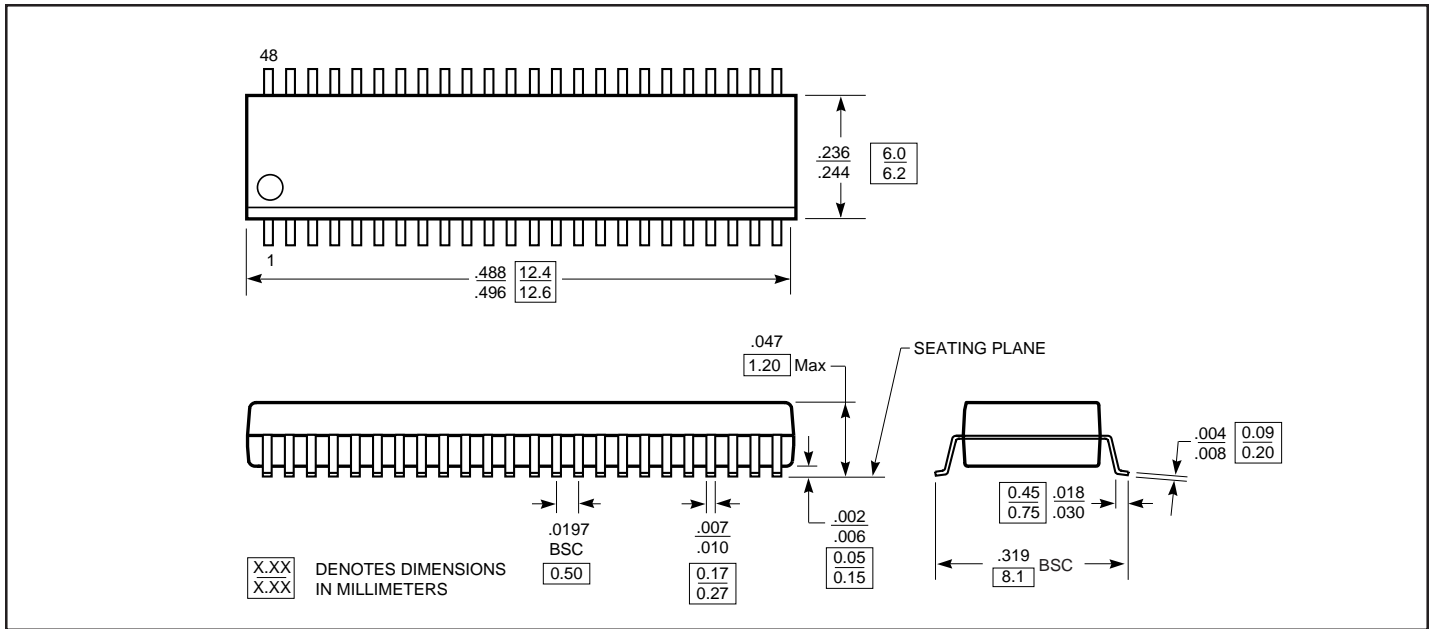

48-Pin TSSOP Package (K)

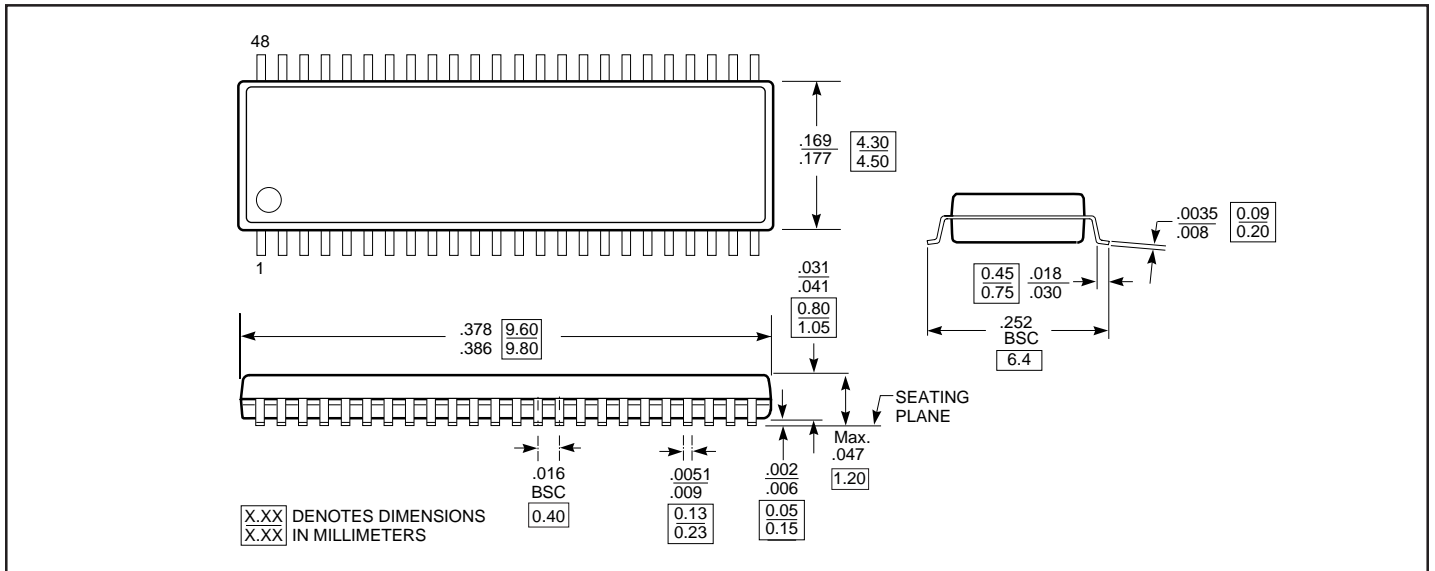



**Ordering Information**

<b>Ordering Code</b>	<b>Package Code</b>	<b>Package Type</b>
PI74SSTVF16857A	A	48-Pin 240-mil TSSOP
PI74SSTVF16857AE	A	Pb-free 48-Pin 240-mil TSSOP
PI74SSTVF16857K	K	48-Pin 173-mil TVSOP
PI74SSTVF16857KE	K	Pb-free 48-Pin 173-mil TVSOP

**Notes:**

1. Thermal characteristics can be found on the company web site at <http://www.pericom.com/packaging/mechanicals.php>