

## Description

The PAM8904Q is a piezo sounder driver designed for driving a ceramic/piezo sounder or speaker with 18V<sub>PP</sub> from a 3V power supply. A programmable charge pump boost converter allows the PAM8904Q V<sub>OUT</sub> to operate in 1x, 2x and 3x mode.

The boost converter operates at a fixed frequency of 1.0MHz and provides a 9V output with a minimum number of external components. PAMs unique drive technology ensures minimal inrush current, low EMI and high efficiency.

To ensure maximum efficiency and battery life, the PAM8904Q includes an auto standby feature which puts the device in sleep mode while there is no valid input signal. A forced shutdown is also available to enable the IC only when required.

To help protect the IC and system, the PAM8904Q includes overtemperature shutdown, overcurrent and short circuit protection.

The PAM8904Q is available in a 16 pin U-QFN3030-16 (Type B) package.

The PAM8904Q is qualified to AEC-Q100 Grade 2 and is Automotive Compliant supporting PPAPs.

## Features

- Supply Voltage Range from 2.3V to 5V
- 18V<sub>PP</sub> Output from a 3V Supply
- Integrated Boost Converter Generates 9V Supply
- Wide Input Signal Capability 20Hz to 300kHz
- Low Current Consumption
- Automatic Standby and Wake-up Control
- Overtemperature Shutdown and Short-Circuit Protection
- Available in Space Saving Packages 16 pin U-QFN3030-16 (Type B) Package with Green Molding
- **Totally Lead-Free & Fully RoHS Compliant (Notes 1 & 2)**
- **Halogen and Antimony Free. "Green" Device (Note 3)**
- **The PAM8904Q is suitable for automotive applications requiring specific change control; this part is AEC-Q100 qualified, PPAP capable, and manufactured in IATF 16949 certified facilities.**

<https://www.diodes.com/quality/product-definitions/>

- Notes:
1. No purposely added lead. Fully EU Directive 2002/95/EC (RoHS), 2011/65/EU (RoHS 2) & 2015/863/EU (RoHS 3) compliant.
  2. See <https://www.diodes.com/quality/lead-free/> for more information about Diodes Incorporated's definitions of Halogen- and Antimony-free, "Green" and Lead-free.
  3. Halogen- and Antimony-free "Green" products are defined as those which contain <900ppm bromine, <900ppm chlorine (<1500ppm total Br + Cl) and <1000ppm antimony compounds.

## Pin Assignments

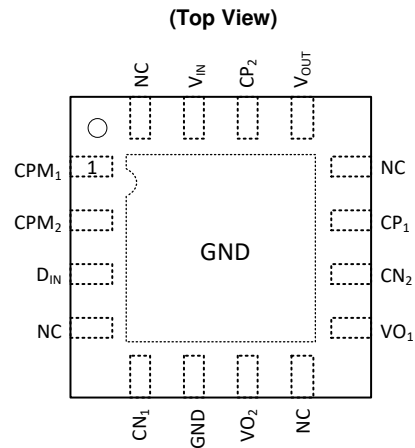

**U-QFN3030-16 (Type B)**

## Applications

- Automotive Alarms
- Dash Board Audio
- GPS
- Electric Vehicle Approach Warning
- Automotive Security Device

**Typical Applications Circuit**

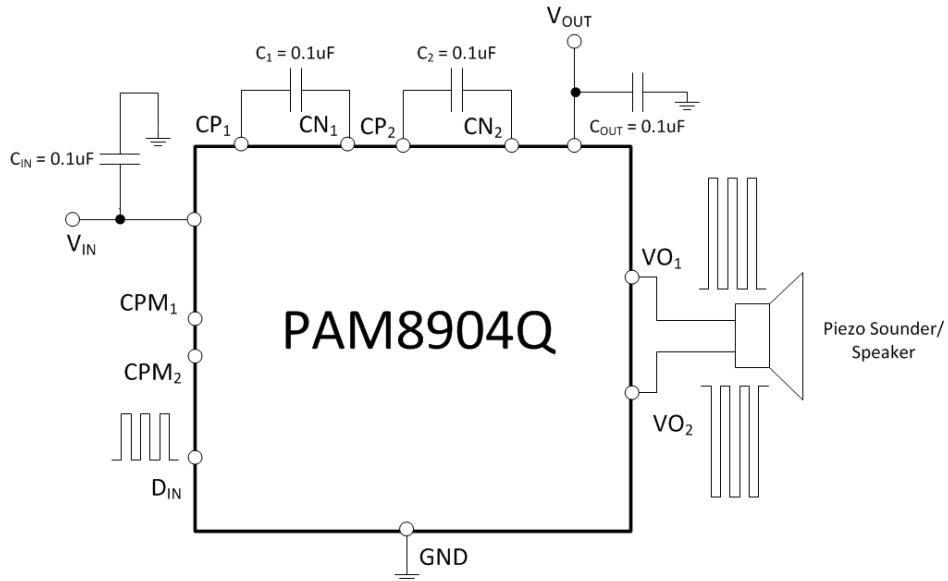

**Pin Descriptions**

Pin Number	Pin Name	I/O/P	Function
1	CPM <sub>1</sub>	I	Charge pump mode select 1
2	CPM <sub>2</sub>	I	Charge pump mode select 2
3	D <sub>IN</sub>	I	Signal Input
4	NC	—	No Connection
5	CN <sub>1</sub>	I	Capacitor 1 Negative Terminal
6	GND	P	Ground
7	VO <sub>2</sub>	O	Positive Output
8	NC	—	No Connection
9	VO <sub>1</sub>	O	Negative Output
10	CN <sub>2</sub>	I	Capacitor 2 Negative Terminal
11	CP <sub>1</sub>	I	Capacitor 1 Positive Terminal
12	NC	—	No Connection
13	V <sub>OUT</sub>	O	Boost Output
14	CP <sub>2</sub>	I	Capacitor 2 Positive Terminal
15	V <sub>IN</sub>	P	Power Supply
16	NC	—	No Connect
PAD	GND	P	Recommended to connect to GND or No Connection

**Absolute Maximum Ratings** (@T<sub>A</sub> = +25°C, unless otherwise specified.)

Symbol	Characteristics	Value	Unit
V <sub>IN</sub>	Supply Voltage	-0.3 to +5.5	V
V <sub>I</sub>	CPM <sub>1</sub> , CPM <sub>2</sub>	GND -0.3 to V <sub>IN</sub> +0.3	V
θ <sub>JA</sub>	Thermal Resistance (Junction to Ambient)	35	°C/W
θ <sub>JC</sub>	Thermal Resistance (Junction to Case)	14	°C/W
T <sub>J</sub>	Operating Junction Temperature Range	-40 to +150	°C
T <sub>STG</sub>	Storage Temperature Range	-65 to +150	°C

**ESD Susceptibility**

HBM	Human Body Model	8	kV
MM	Machine Model	600	V
CDM	Charged Device Model	1	kV

Caution: Stresses greater than the 'Absolute Maximum Ratings' specified above, may cause permanent damage to the device. These are stress ratings only; functional operation of the device at conditions between maximum recommended operating conditions and absolute maximum ratings is not implied. Device reliability may be affected by exposure to absolute maximum rating conditions for extended periods of time.

(Semiconductor devices are ESD sensitive and may be damaged by exposure to ESD events. Suitable ESD precautions should be taken when handling and transporting these devices.)

**Recommended Operating Conditions** (@T<sub>A</sub> = +25°C, unless otherwise specified.)

Symbol	Characteristics	Min	Max	Unit
V <sub>IN</sub>	Supply Voltage	2.3	5.0	V
V <sub>IH</sub>	High-Level Input Voltage	CPM <sub>1</sub> , CPM <sub>2</sub>	V <sub>IN</sub> +0.3	V
V <sub>IL</sub>	Low-Level Input Voltage	CPM <sub>1</sub> , CPM <sub>2</sub>	+0.4	V
T <sub>A</sub>	Operating Free-Air Temperature	-40	+105	°C

**Electrical Characteristics** (@T<sub>A</sub> = +25°C, unless otherwise specified.)

Symbol	Parameter	Conditions	Min	Typ	Max	Unit
V <sub>OUT</sub>	Output Voltage Range	Note 4	2.1	—	12	V
V <sub>OUT1</sub>	Output Voltage	1x Mode	2.8	—	3	V
V <sub>OUT2</sub>		2x Mode	5.2	—	6	V
V <sub>OUT3</sub>		3x Mode	7.2	—	9	V
I <sub>DD11</sub>	Operating Current 1	1x Mode, C <sub>PIEZO</sub> = No Load	—	50	—	μA
I <sub>DD12</sub>		2x Mode, C <sub>PIEZO</sub> = No Load	—	720	—	μA
I <sub>DD13</sub>		3x Mode, C <sub>PIEZO</sub> = No Load	—	1,700	—	μA
I <sub>DD21</sub>	Operating Current 2	1x Mode, Single-ended application	—	0.3	—	mA
I <sub>DD22</sub>		2x Mode, Single-ended application	—	1.4	—	mA
I <sub>DD23</sub>		3x Mode, Single-ended application	—	3.9	—	mA
I <sub>DD31</sub>	Operating Current 3	1x Mode, Differential application	—	0.9	—	mA
I <sub>DD32</sub>		2x Mode, Differential application	—	3.8	—	mA
I <sub>DD33</sub>		3x Mode, Differential application	—	8.5	—	mA
I <sub>SD</sub>	Shutdown Current	D <sub>IN</sub> = 0V	—	—	1	μA
f <sub>IN</sub>	Input Frequency	Rectangular pulse on D <sub>IN</sub>	0.02	—	300	kHz
f <sub>OSC</sub>	Oscillating Frequency	—	—	1	—	MHz
t <sub>ON1</sub>	V <sub>OUT</sub> Start Delay Time	1x Mode, From D <sub>IN</sub> signal High to 90% V <sub>OUT</sub> steady state	—	270	—	μs
t <sub>ON2</sub>		2x Mode, From D <sub>IN</sub> signal High to 90% V <sub>OUT</sub> steady state	—	320	—	μs
t <sub>ON3</sub>		3x Mode, From D <sub>IN</sub> signal High to 90% V <sub>OUT</sub> steady state	—	350	—	μs
t <sub>OFF</sub>	Shutdown Delay Time	D <sub>IN</sub> = H- >L	—	42	—	ms
I <sub>SC</sub>	Output Short-Circuit Current	—	—	40	—	mA
OTP	Thermal Shutdown	Junction temperature	—	+150	—	°C
OTPHYS	Thermal Shutdown Hysteresis	—	—	+37	—	°C
V <sub>IH</sub>	Control Terminal Voltage H	CPM <sub>1</sub> , CPM <sub>2</sub> , D <sub>IN</sub> pins	0.8 x V <sub>IN</sub>	—	V <sub>IN</sub>	V
V <sub>IL</sub>	Control Terminal Voltage L	CPM <sub>1</sub> , CPM <sub>2</sub> , D <sub>IN</sub> pins	0	—	0.2 x V <sub>IN</sub>	V
I <sub>IH1</sub>	Control Terminal Current 1	D <sub>IN</sub> = 3V	—	—	1	μA
I <sub>IH2</sub>	Control Terminal Current 2	VCPM <sub>1</sub> , VCPM <sub>2</sub> = 3V, D <sub>IN</sub> = 3V	—	—	1	μA
I <sub>IH3</sub>	Control Terminal Current 3	VCPM <sub>1</sub> , VCPM <sub>2</sub> = 3V, D <sub>IN</sub> = 0V	—	—	1	μA
C <sub>L</sub>	Capacitive Load	—	—	15	50	nF

Note: 4. It is possible to drive V<sub>OUT</sub>, VO<sub>1</sub> and VO<sub>2</sub> to 3x V<sub>DD</sub>. A supply voltage of 4V or more should not be used in 3x mode as this will exceed the maximum output voltage rating.

**Performance Characteristics** (@ $T_A = +25^\circ\text{C}$ ,  $V_{IN} = 3.0\text{V}$ ,  $C_{Piezo} = 15\text{nF}$ ,  $f_{DIN} = 4\text{kHz}$ , unless otherwise specified.)

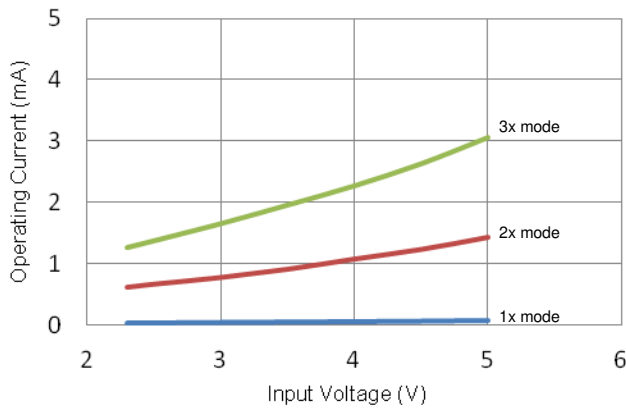

Operating Current vs Input Voltage (No Load)

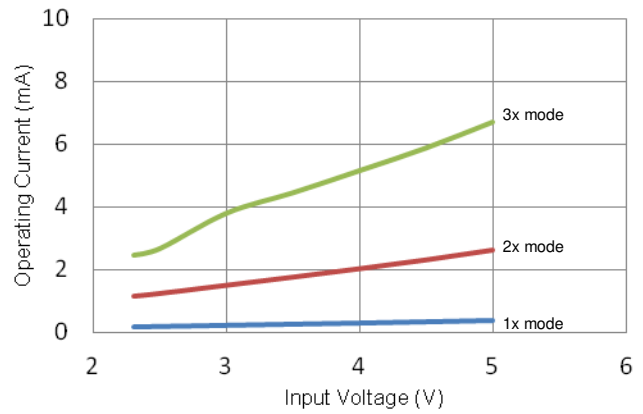

Operating Current vs Input Voltage (Single Ended Output)

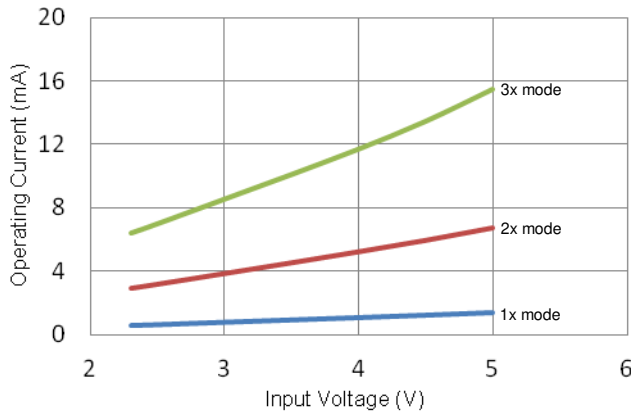

Operating Current vs Input Voltage (Differential output)

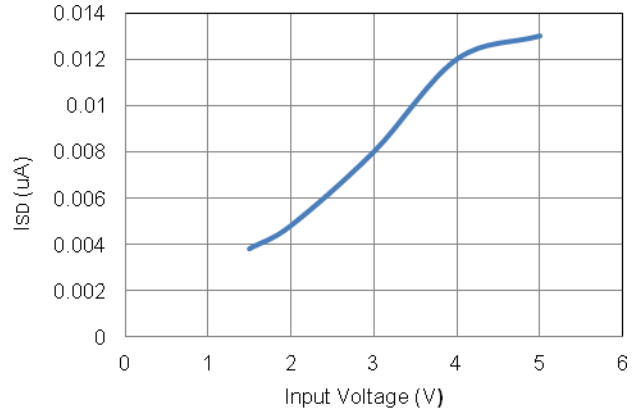

Shutdown Current vs Input Voltage

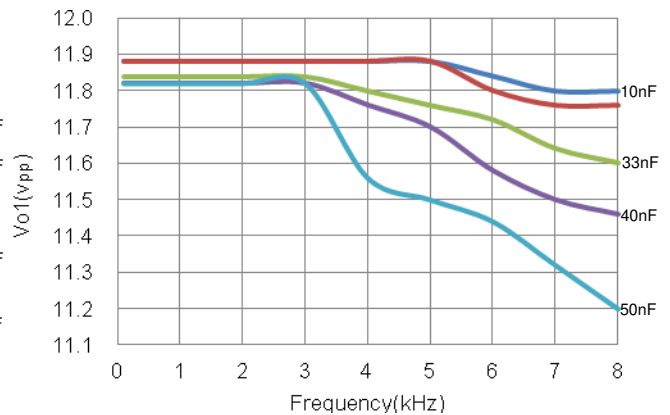
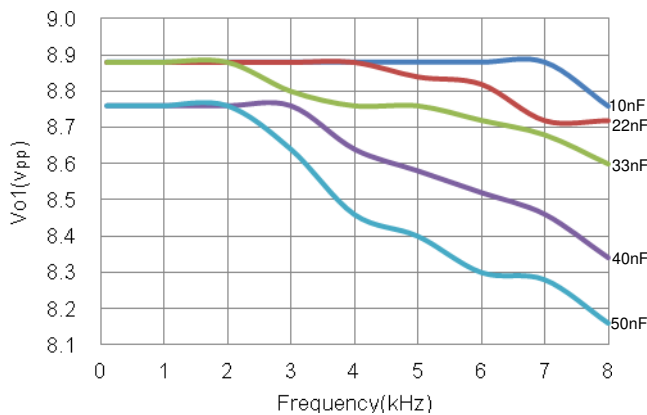

**Performance Characteristics** (continued. @T<sub>A</sub> = +25°C, V<sub>IN</sub> = 3.0V, C<sub>Piezo</sub> = 15nF, f<sub>DIN</sub> = 4kHz, unless otherwise specified.)

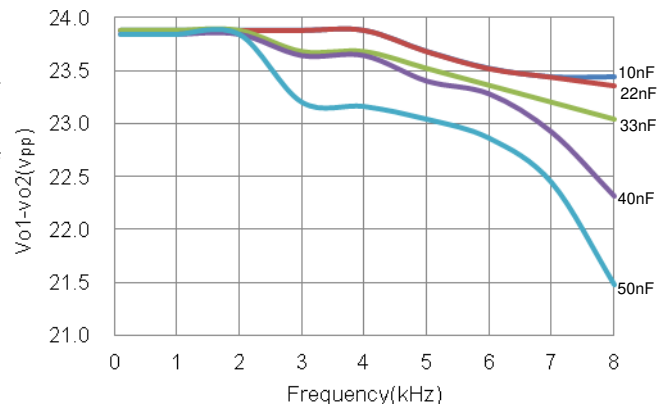
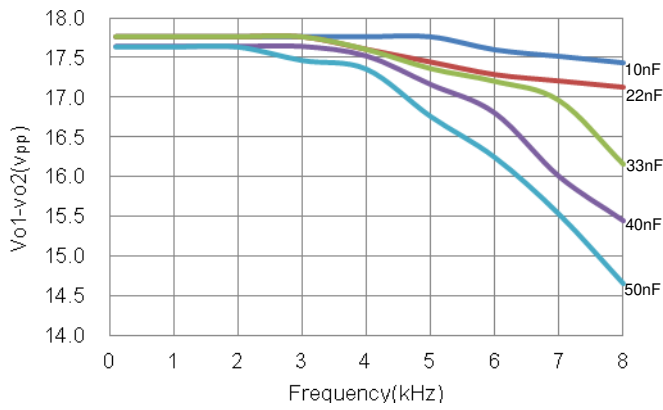

## Application Information

### Charge Pump Mode Setting

The Charge Pump Mode (CPM) pins CPM<sub>1</sub> and CPM<sub>2</sub> are used to set the charge pump into mode 1x V<sub>DD</sub>, 2x V<sub>DD</sub>, 3x V<sub>DD</sub> or they can be used to put the PAM8904Q in to a forced low current shutdown mode.

D <sub>IN</sub>	CPM <sub>1</sub>	CPM <sub>2</sub>	MODE
0	—	—	Shutdown Mode
1	0	0	Shutdown Mode
1	0	1	1x Mode
1	1	0	2x Mode
1	1	1	3x Mode

Care must be taken when using the 3x mode with a V<sub>DD</sub> supply of 4V or more as this will force the V<sub>OUT</sub> to exceed its maximum specification. The table shows the safe operating range of the PAM8904Q.

V <sub>DD</sub> Range	Mode
2.3V to 3.9V	1x, 2x and 3x
4.0V to 5.0V	1x and 2x only

### Timing Chart and Device Operation

When one or both of the CPM pins are pulled high, the device enters normal operation mode, refer to the above table for the mode selection. Once the PAM8904Q senses a valid signal on the D<sub>IN</sub> pin, the charge pump will start and provide the desired voltage on the V<sub>OUT</sub> pin and the output drive VO<sub>1</sub> and VO<sub>2</sub> start to function after time t<sub>ON</sub> which is typically between 270μs and 350μs depending on the mode chosen. Once the input signal on D<sub>IN</sub> is removed, the PAM8904Q senses this and waits typically 42ms to ensure the signal has been removed. If there is no further valid signal within the time period t<sub>OFF</sub>, the PAM8904Q enters into a low current standby mode.

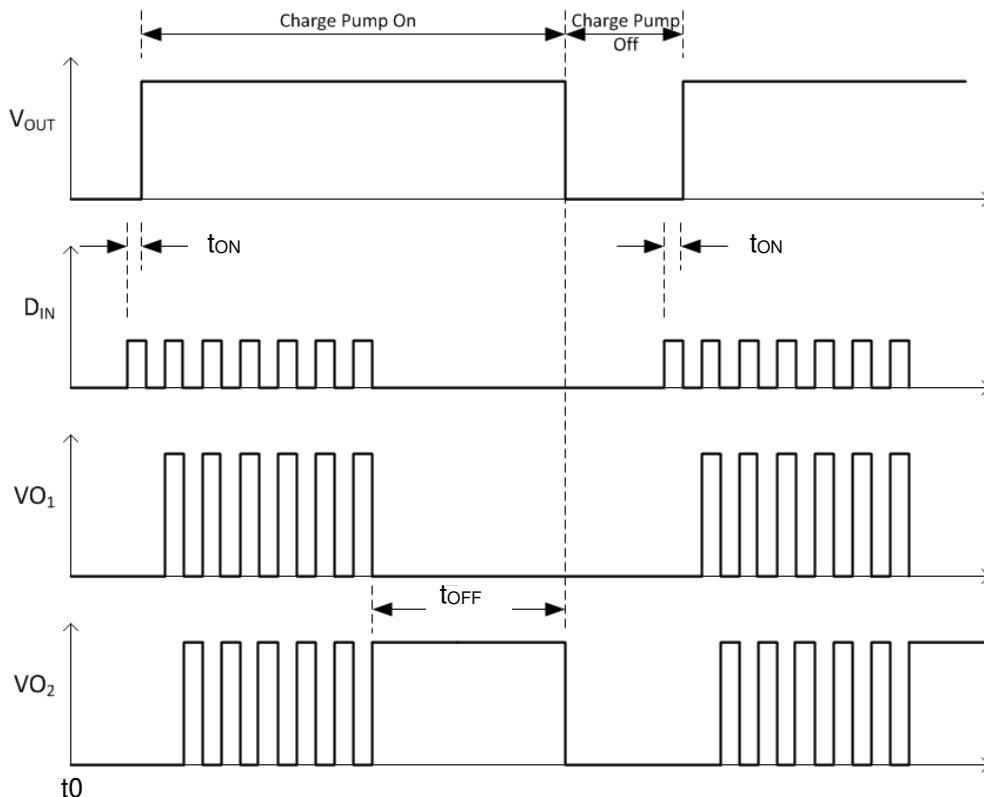

**Application Information** (continued)

**Output Configuration**

The PAM8904Q is able to be configured either in a differential or a single ended configuration.

**Differential Output Typical Application Circuit**

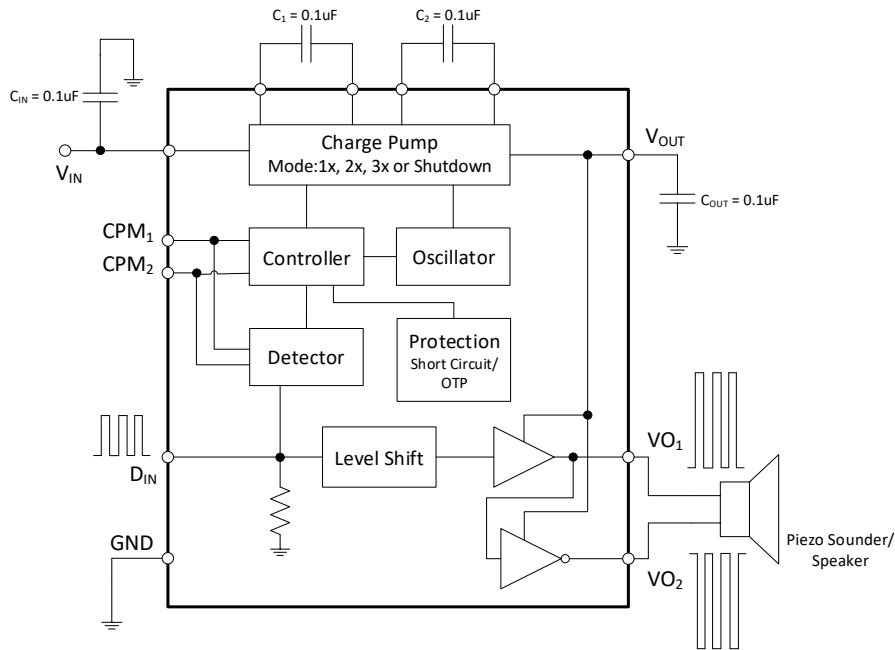

**Single Ended Output Typical Application Circuit**

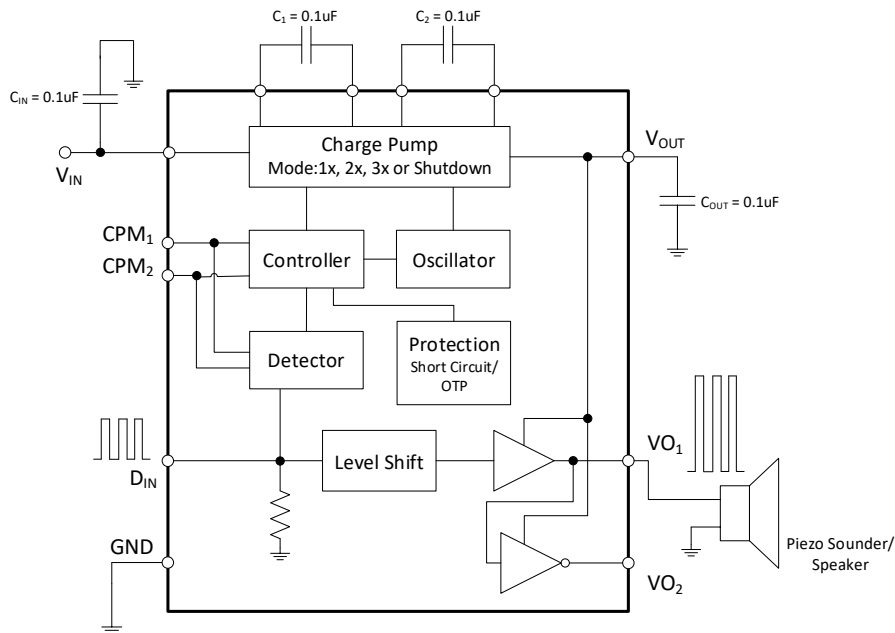

When using the PAM8904Q with a single ended output, the  $VO_2$  pin should be left open circuit.



## Application Information (continued)

### Short-Circuit Protection

The PAM8904Q has short circuit protection circuitry on the outputs to prevent damage. Once a short circuit is detected on the outputs the chip will limit the total current to protect the output device. This is not a latched fault; once the short is removed the normal operation is restored.

### Thermal Protection

If the junction temperature of the PAM904Q exceeds +150°C the device will enter overtemperature shutdown. The outputs and the charge pump will be switched off. Once the junction temperature cools down to its normal operating condition, the IC will re-start automatically.

## Ordering Information

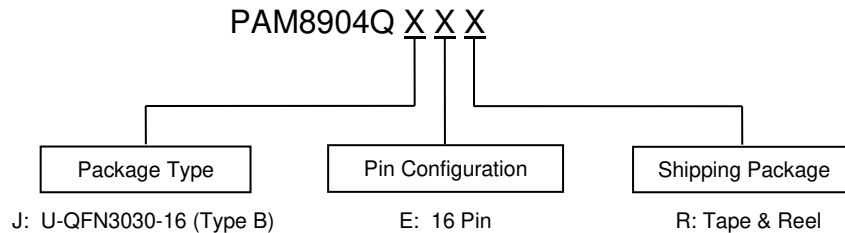

Part Number	Package Code	Package Type (Notes 5 & 6)	7" Tape and Reel		Qualification (Note 7)
			Quantity	Part Number Suffix	
PAM8904QJER	J	U-QFN3030-16 (Type B)	3,000/Tape & Reel	R	Automotive Compliant

- Notes:
5. Pad layout shown at <http://www.diodes.com/package-outlines.html>.
  6. For Tape and reel information see <https://www.diodes.com/assets/Packaging-Support-Docs/ap02007.pdf>.
  7. PAM8904Q has been qualified to AEC-Q100 grade 2 and is classified as "Automotive Compliant" supporting PPAP documentation. Automotive, AEC-Q100 and standard products are electrically and thermally the same, except where specified. For more information, please refer to <https://www.diodes.com/quality/product-definitions/>. See PAM8904 datasheet for commercial qualified versions.

## Marking Information

### U-QFN3030-16 (Type B)

(Top View)

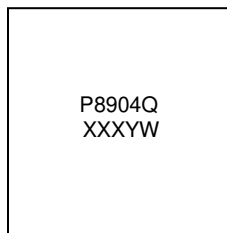

P8904Q: Product Code  
 XXX: Internal Code  
 Y: Year 0-9  
 W: Week: A~Z: 1~26 weeks;  
 a~z: 27~52 weeks;  
 z represents 52 and 53 weeks

**Package Outline Dimensions**

Please see <http://www.diodes.com/package-outlines.html> for the latest version.

**U-QFN3030-16 (Type B)**

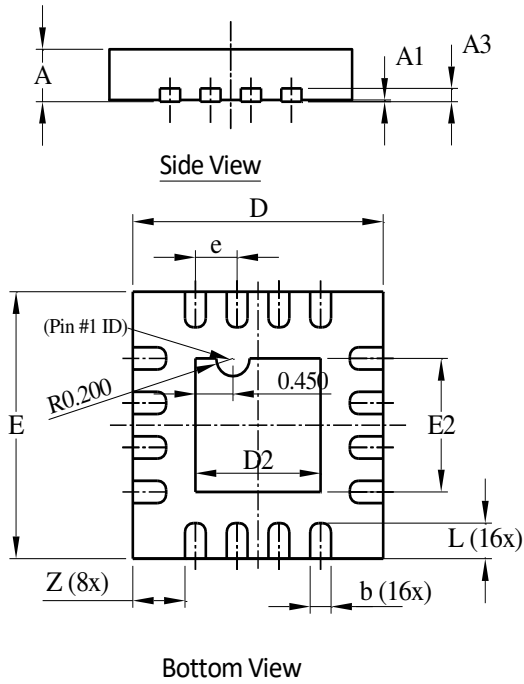

U-QFN3030-16 (Type B)			
Dim	Min	Max	Typ
A	0.55	0.65	0.60
A1	0	0.05	0.02
A3	—	—	0.15
b	0.18	0.28	0.23
D	2.95	3.05	3.00
D2	1.40	1.60	1.50
E	2.95	3.05	3.00
E2	1.40	1.60	1.50
e	—	—	0.50
L	0.35	0.45	0.40
Z	—	—	0.625
All Dimensions in mm			

**Suggested Pad Layout**

Please see <http://www.diodes.com/package-outlines.html> for the latest version.

**U-QFN3030-16 (Type B)**

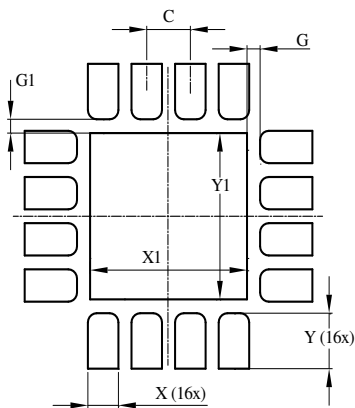

Dimensions	Value (in mm)
C	0.500
G	0.150
G1	0.150
X	0.350
X1	1.800
Y	0.600
Y1	1.800

**IMPORTANT NOTICE**

1. DIODES INCORPORATED AND ITS SUBSIDIARIES ("DIODES") MAKE NO WARRANTY OF ANY KIND, EXPRESS OR IMPLIED, WITH REGARDS TO ANY INFORMATION CONTAINED IN THIS DOCUMENT, INCLUDING, BUT NOT LIMITED TO, THE IMPLIED WARRANTIES OF MERCHANTABILITY, FITNESS FOR A PARTICULAR PURPOSE OR NON-INFRINGEMENT OF THIRD PARTY INTELLECTUAL PROPERTY RIGHTS (AND THEIR EQUIVALENTS UNDER THE LAWS OF ANY JURISDICTION).
2. The Information contained herein is for informational purpose only and is provided only to illustrate the operation of Diodes products described herein and application examples. Diodes does not assume any liability arising out of the application or use of this document or any product described herein. This document is intended for skilled and technically trained engineering customers and users who design with Diodes products. Diodes products may be used to facilitate safety-related applications; however, in all instances customers and users are responsible for (a) selecting the appropriate Diodes products for their applications, (b) evaluating the suitability of the Diodes products for their intended applications, (c) ensuring their applications, which incorporate Diodes products, comply the applicable legal and regulatory requirements as well as safety and functional-safety related standards, and (d) ensuring they design with appropriate safeguards (including testing, validation, quality control techniques, redundancy, malfunction prevention, and appropriate treatment for aging degradation) to minimize the risks associated with their applications.
3. Diodes assumes no liability for any application-related information, support, assistance or feedback that may be provided by Diodes from time to time. Any customer or user of this document or products described herein will assume all risks and liabilities associated with such use, and will hold Diodes and all companies whose products are represented herein or on Diodes' websites, harmless against all damages and liabilities.
4. Products described herein may be covered by one or more United States, international or foreign patents and pending patent applications. Product names and markings noted herein may also be covered by one or more United States, international or foreign trademarks and trademark applications. Diodes does not convey any license under any of its intellectual property rights or the rights of any third parties (including third parties whose products and services may be described in this document or on Diodes' website) under this document.
5. Diodes products are provided subject to Diodes' Standard Terms and Conditions of Sale (<https://www.diodes.com/about/company/terms-and-conditions/terms-and-conditions-of-sales/>) or other applicable terms. This document does not alter or expand the applicable warranties provided by Diodes. Diodes does not warrant or accept any liability whatsoever in respect of any products purchased through unauthorized sales channel.
6. Diodes products and technology may not be used for or incorporated into any products or systems whose manufacture, use or sale is prohibited under any applicable laws and regulations. Should customers or users use Diodes products in contravention of any applicable laws or regulations, or for any unintended or unauthorized application, customers and users will (a) be solely responsible for any damages, losses or penalties arising in connection therewith or as a result thereof, and (b) indemnify and hold Diodes and its representatives and agents harmless against any and all claims, damages, expenses, and attorney fees arising out of, directly or indirectly, any claim relating to any noncompliance with the applicable laws and regulations, as well as any unintended or unauthorized application.
7. While efforts have been made to ensure the information contained in this document is accurate, complete and current, it may contain technical inaccuracies, omissions and typographical errors. Diodes does not warrant that information contained in this document is error-free and Diodes is under no obligation to update or otherwise correct this information. Notwithstanding the foregoing, Diodes reserves the right to make modifications, enhancements, improvements, corrections or other changes without further notice to this document and any product described herein. This document is written in English but may be translated into multiple languages for reference. Only the English version of this document is the final and determinative format released by Diodes.
8. Any unauthorized copying, modification, distribution, transmission, display or other use of this document (or any portion hereof) is prohibited. Diodes assumes no responsibility for any losses incurred by the customers or users or any third parties arising from any such unauthorized use.

Copyright © 2021 Diodes Incorporated

[www.diodes.com](http://www.diodes.com)