

P.W.BOARD PATTERN LAYOUT
(REFERENCE)

注記 NOTES

1. 使用材料 MATERIAL
ハウジング：液晶ポリマー(LCP)、ガラス充填、UL94 V-0、黒
HOUSING：LIQUID CRYSTAL POLYMER (LCP),
GLASS FILLED, UL94 V-0, BLACK
ターミナル：銅合金
TERMINAL：COPPER ALLOY
2. めっき仕様 PLATING
ターミナル TERMINAL
コンタクト部：金めっき
テール部：金めっき
下地：ニッケルめっき
*コンタクト部とテール部は、ニッケルメッキによって
分断された金メッキとなります。
CONTACT AREA：GOLD PLATING
SOLDER TAIL AREA：GOLD PLATING
UNDERPLATE：NICKEL PLATING
* GOLD PLATING AREA IS DIVIDED INTO
CONTACT AREA AND SOLDER TAIL AREA
BY NICKEL PLATING.
- △ (全極数/2) = 偶数の場合に適用。
APPLY ONLY WHEN ONE-HALF OF
THE NUMBER OF CIRCUITS IS EVEN NUMBER.
4. 嵌合相手：503836シリーズ
MATE WITH：503836 SERIES
5. テール平坦度は、0.1MAX.
TAIL COPLANARITY TO BE 0.1 MAXIMUM.
6. ELV及びRoHS適合品
ELV AND RoHS COMPLIANT.

RELEASED EC NO.: J2012-1383 DRAWN: MTAKAHASHI 03 2012/05/14 CH'KDR: TAKEUCHI 2012/05/14 APPR: MSASAO 2012/05/14	GENERAL TOLERANCES (UNLESS SPECIFIED)		DIMENSION STYLE MM ONLY		SCALE 10:1	DESIGN UNITS METRIC	THIRD ANGLE PROJECTION	
	10 UNDER	± 0.2	DRAWN BY MTAKAHASHI	DATE 032012/05/14	TITLE 0.5 BB CONN. HGT=3.0 PLUG ASSY			
	10 OVER 30 UNDER	± 0.25	CHECKED BY RTAKEUCHI	DATE 2012/05/14				
	30 OVER	± 0.3	APPROVED BY MSASAO	DATE 2012/05/14	molex			
ANGULAR ±1 °		MATERIAL NO. SEE CHART		DOCUMENT NO. SD-503842-001				
DRAFT WHERE APPLICABLE MUST REMAIN WITHIN DIMENSIONS		SIZE A3		THIS DRAWING CONTAINS INFORMATION THAT IS PROPRIETARY TO MOLEX INCORPORATED AND SHOULD NOT BE USED WITHOUT WRITTEN PERMISSION				

注記 NOTES

- 製品詳細寸法については製品単体図面を参照下さい。
FOR DETAIL OF CONNECTOR DIMENSIONS,
PLEASE SEE THE DRAWING OF CONNECTOR ITSELF (NOT PACKAGED).
- 梱包数量: 2500 個/リール
NUMBER OF CONNECTORS : 2500PCS/REEL
- リードテープ長さ LEAD TAPE LENGTH

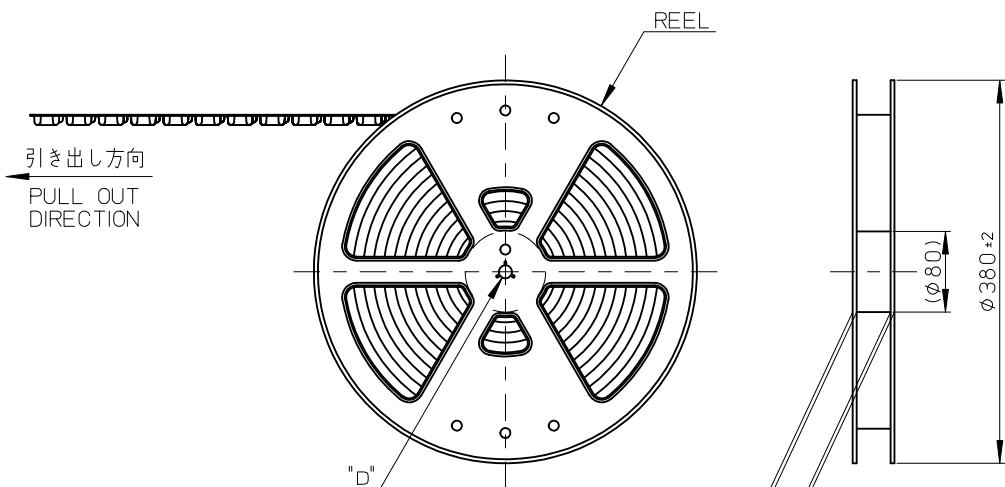

引き出し方向
PULL OUT DIRECTION

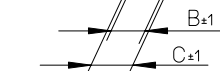

DETAIL "D"

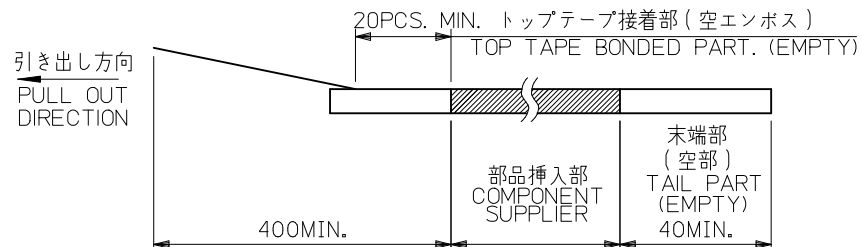

- 材料 MATERIAL
キャリアテープ (CARRIER TAPE): ポリスチレン (POLYSTYRENE)
トップテープ (TOP TAPE): PET, OTHER
リール (REEL): ポリスチレン (PS) <リサイクル材を含む>
POLYSTYRENE (PS) <RECYCLE MATERIAL CONTAINED>
- ELV及びRoHS適合品
ELV AND RoHS COMPLIANT

RELEASED EC NO.: J2012-1387 DRWN: MTAKAHASHI 03 2012/05/15 CHKD: RTAKEUCHI 2012/05/15 APPR: MSASAO 2012/05/16	GENERAL TOLERANCES (UNLESS SPECIFIED)		DIMENSION STYLE MM ONLY		SCALE ---	DESIGN UNITS METRIC	MODEL NO. 503842-**10
	10 UNDER ± ---		DRAWN BY DATE MTAKAHASHI 03 2012/05/15		TITLE		
	10 OVER 30 UNDER ± ---		CHECKED BY DATE RTAKEUCHI 2012/05/15		0.5 BB CONN. H=3.0 PLUG ASSY EMBSTP PKG		
	30 OVER ± ---		APPROVED BY DATE MSASAO 2012/05/16		molex		
ANGULAR ± --- °		MATERIAL NO.		DOCUMENT NO.		SHEET NO.	
DRAFT WHERE APPLICABLE MUST REMAIN WITHIN DIMENSIONS		SEE TABLE		SD-503842-002		1 OF 2	
O		SIZE A3		THIS DRAWING CONTAINS INFORMATION THAT IS PROPRIETARY TO MOLEX INCORPORATED AND SHOULD NOT BE USED WITHOUT WRITTEN PERMISSION			

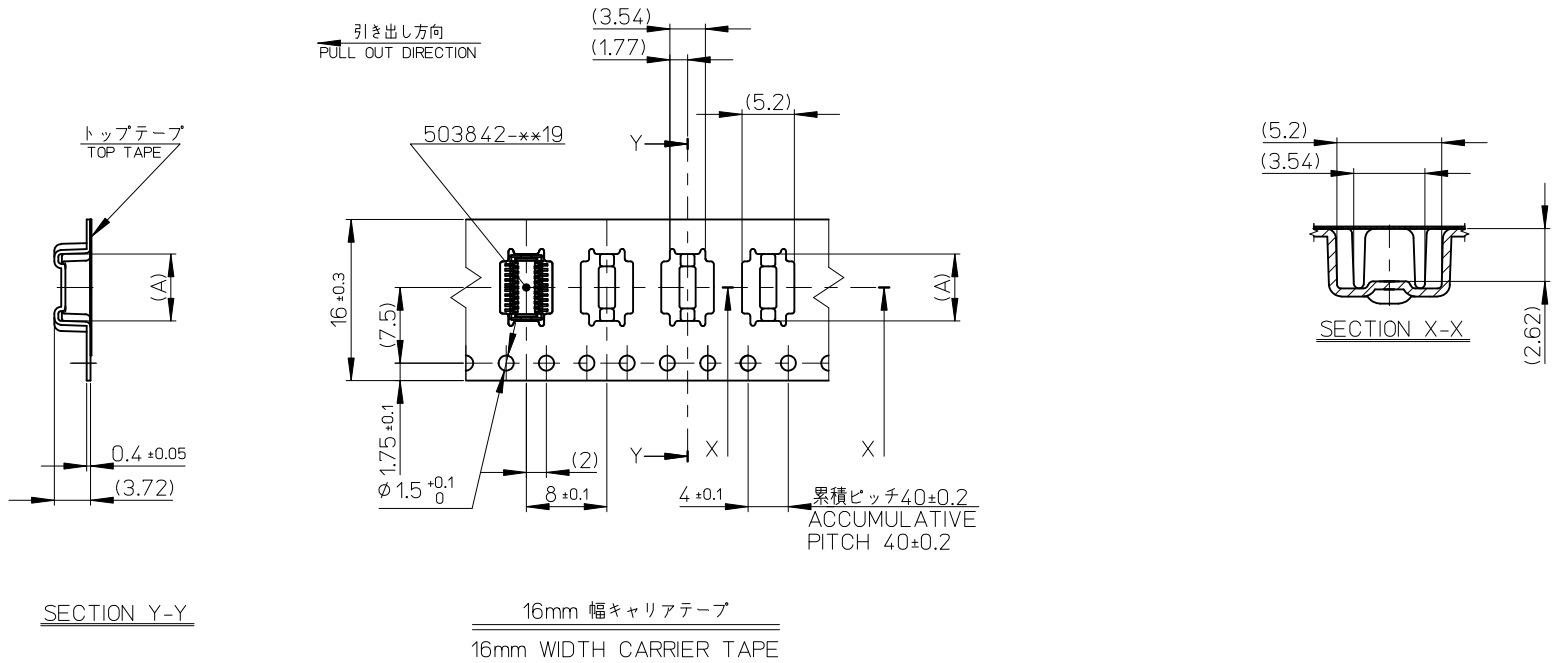

16	21.4	17.4	7.65	503842-2410	24
			6.65	503842-2010	20
キャリアテープ幅 CARRIER TAPE WIDTH			C	B	(A)
			MATERIAL No.		CKT.
			MODEL No.		503842-**10

RELEASED EC NO.: J2012-1387 DRWN: MTAKAHASHI 03 2012/05/15 CHK'D: RTAKEUCHI 2012/05/15 APPR: MSASAO 2012/05/16	GENERAL TOLERANCES (UNLESS SPECIFIED)		DIMENSION STYLE MM ONLY		SCALE ---	DESIGN UNITS METRIC	THIRD ANGLE PROJECTION
	10 UNDER	± ---	DRAWN BY MTAKAHASHI 03	DATE 2012/05/15	TITLE 0.5 BB CONN. H=3.0 PLUG ASSY EMBSTP PKG		
	10 OVER 30 UNDER	± ---	CHECKED BY RTAKEUCHI	DATE 2012/05/15	molex DOCUMENT NO. SD-503842-002 SHEET NO. 2 OF 2		
	30 OVER	± ---	APPROVED BY MSASAO	DATE 2012/05/16			
ANGULAR	± --- °	MATERIAL NO.		SEE CHART			
DRAFT WHERE APPLICABLE MUST REMAIN WITHIN DIMENSIONS		THIS DRAWING CONTAINS INFORMATION THAT IS PROPRIETARY TO MOLEX INCORPORATED AND SHOULD NOT BE USED WITHOUT WRITTEN PERMISSION					