

POWER MANAGEMENT

Description

The EZ1585 series of high performance positive voltage regulators are designed for use in applications requiring low dropout performance at up to 4.6A. Additionally, the EZ1585 series provides excellent regulation over variations in line, load and temperature.

Outstanding features include low dropout performance at rated current, fast transient response, internal current limiting and thermal shutdown protection of the output device.

A variety of options are available for maximum flexibility: the EZ1585C is intended for commercial applications and has both fixed and adjustable voltage options; the EZ1585I is intended for industrial applications and is adjustable only.

All devices are available in the popular TO-220 and TO-263 packages.

Features

- ◆ Low dropout voltage: 1.3V max. for EZ1585C and 1.4V max. for EZ1585I
- ◆ Full current rating over line and temperature
- ◆ Fast transient response
- ◆ ±2% total output regulation over line, load and temperature
- ◆ Adjust pin current max 90µA over temperature
- ◆ Fixed/adjustable output voltage (EZ1585C)
- ◆ Line regulation typically 0.015%
- ◆ Load regulation typically 0.05%
- ◆ Industrial temperature range (EZ1585I)
- ◆ TO-220 and TO-263 packages. Available in RoHS compliant package

Applications

- ◆ Printer and plotter supplies
- ◆ Instrumentation
- ◆ Medical equipment
- ◆ Microcontroller systems
- ◆ Telecommunication systems
- ◆ Motherboards
- ◆ Switching supply post regulation

Typical Application Circuit

Fixed Voltage Regulator

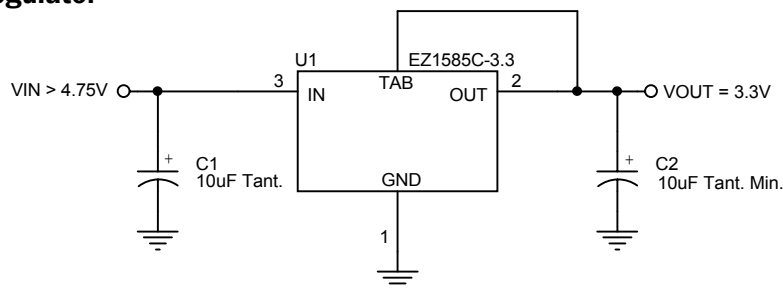

Adjustable Voltage Regulator

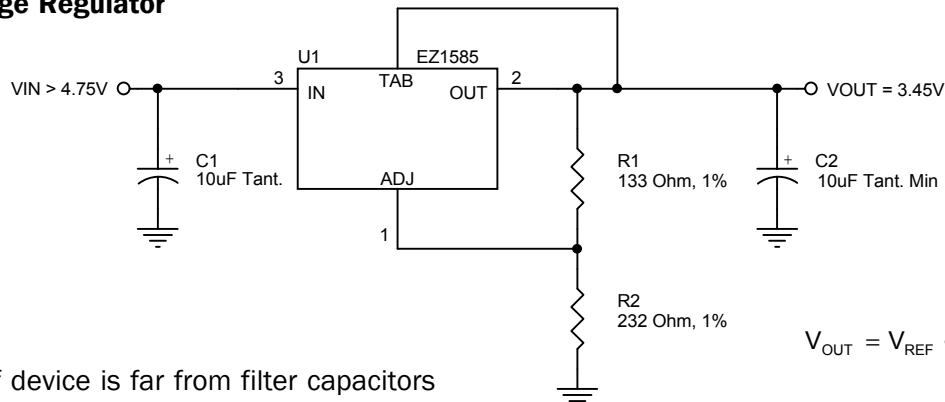

Notes:

- (1) C1 needed if device is far from filter capacitors
- (2) C2 minimum value required for stability

POWER MANAGEMENT
Absolute Maximum Ratings

Exceeding the specifications below may result in permanent damage to the device, or device malfunction. Operation outside of the parameters specified in the Electrical Characteristics section is not implied.

| Parameter | Symbol | Maximum | Units |
|--|---------------|------------------------|-------|
| Input Supply Voltage | V_{IN} | 7 | V |
| Power Dissipation | P_D | Internally Limited | W |
| Thermal Resistance Junction to Case TO-220 TO-263 | θ_{JC} | 3 3 | °C/W |
| Thermal Resistance Junction to Ambient TO-220 TO-263 | θ_{JA} | 50 60 | °C/W |
| Operating Ambient Temperature Range EZ1585C EZ1585I | T_A | 0 to 70 -40 to 85 | °C |
| Operating Junction Temperature Range EZ1585C EZ1585I | T_J | 0 to 125 -40 to 125 | °C |
| Storage Temperature Range | T_{STG} | -65 to 150 | °C |
| Lead Temperature (Soldering) 10 Sec. | T_{LEAD} | 300 | °C |
| ESD Rating (Human Body Model) | ESD | 2 | kV |

Electrical Characteristics

Unless otherwise specified: Adj. $V_{IN} = 2.75V$ to $7.0V$ and Adj. $I_O = 10mA$ to $4.6A$; Fixed $V_{IN} = 4.75$ to $7.0V$ and Fixed $I_O = 0$ mA to $4.6A$.
Values in **bold** apply over full operating ambient temperature range.

| Parameter | Symbol | V_{IN} | I_O | Min | Typ | Max | Units |
|--|----------------|----------|-------|---|--------------|---|-------|
| Output Voltage ⁽¹⁾ EZ1585C-X.X | V_O | 5V | 0mA | 0.99 V_O 0.98V_O | V_O | 1.01 V_O 1.02V_O | V |
| Reference Voltage ⁽¹⁾ EZ1585C, EZ1585I | V_{REF} | 5V | 10mA | 1.238 1.225 | 1.250 | 1.262 1.275 | V |
| Line Regulation ⁽¹⁾ | $REG_{(LINE)}$ | | 10mA | | 0.015 | 0.2 | % |
| Load Regulation ⁽¹⁾ | $REG_{(LOAD)}$ | 5V | | | 0.05 | 0.4 | % |
| Dropout Voltage ⁽¹⁾⁽²⁾ EZ1585C, EZ1585C-X.X EZ1585I | V_D | | 4.6A | | 1.20 1.20 | 1.30 1.40 | V |
| Current Limit | I_{CL} | | | 4.7 | 7.5 | | A |

POWER MANAGEMENT
Electrical Characteristics (Cont)

Unless otherwise specified: Adj. $V_{IN} = 2.75V$ to $7.0V$ and Adj. $I_O = 10mA$ to $4.6A$; Fixed $V_{IN} = 4.75$ to $7.0V$ and Fixed $I_O = 0$ mA to $4.6A$.
 Values in **bold** apply over full operating ambient temperature range.

| Parameter | Symbol | V_{IN} | I_O | Min | Typ | Max | Units |
|--|------------------|----------|-------|-----------|------------|-----------|---------|
| Quiescent Current Fixed Voltage Version | I_Q | 5V | | | 10 | 13 | mA |
| Temperature Coefficient | T_C | | | | 0.005 | | %/°C |
| Adjust Pin Current | I_{ADJ} | | | | 55 | 90 | μA |
| Adjust Pin Current Change | ΔI_{ADJ} | | | | 0.2 | 5 | μA |
| Temperature Stability | T_S | 5V | 0.5A | | 0.5 | | % |
| Minimum Load Current Adj Voltage Versions | I_O | 5V | | | 5 | 10 | mA |
| RMS Output Noise ⁽³⁾ | V_N | | | | 0.003 | | % V_O |
| Ripple Rejection Ratio ⁽⁴⁾ | R_A | 5V | 4.6A | 60 | 72 | | dB |

NOTES:

- (1) Low duty cycle pulse testing with Kelvin connections required.
- (2) $\Delta V_{OUT}, \Delta V_{REF} = 1\%$
- (3) Bandwidth of 10 Hz to 10 kHz.
- (4) 120 Hz input ripple (C_{ADJ} for ADJ = $25\mu F$).

POWER MANAGEMENT

Pin Configurations

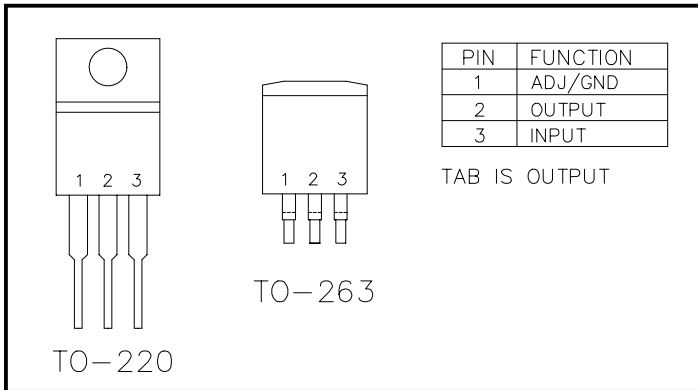

Ordering Information

| Device ⁽¹⁾⁽²⁾ | Package |
|--|-----------------------|
| EZ1585CM-X.X.TR EZ1585IM.TR EZ1585CM-X.XTRT ⁽⁵⁾ | TO-263 ⁽³⁾ |
| EZ1585CT-X.X EZ1585IT EZ1585CT-X.XT ⁽⁵⁾ | TO-220 ⁽⁴⁾ |

Notes:

- (1) Where X.X denotes voltage options (EZ1585C only). Available voltages are: 2.5V and 3.3V. Leave blank for adjustable version (1.3 to 5.7V). Contact factory for additional voltage options.
- (2) Where C and I denote Commercial (0°C to 70°C) and Industrial (-40°C to 85°C) ambient temperature ranges.
- (3) Only available in tape and reel packaging. A reel contains 800 devices.
- (4) Only available in tube packaging. A tube contains 50 devices.
- (5) This product is RoHS compliant.

Pin Descriptions

| Pin | Pin Name | Pin Function |
|-----|----------|---|
| 1 | ADJUST | This pin is the negative side of the reference voltage for adjustable devices. Transient response can be improved by adding a small bypass capacitor from the adjust pin to ground. |
| | GROUND | This pin is the bottom end of the internal resistor feedback chain for fixed output voltage parts, and should be connected to ground. |
| 2 | OUTPUT | This is the power output of the device and is electrically connected to the TAB. |
| 3 | INPUT | This is the input supply pin for both the control circuitry and the pass device. |

Block Diagram

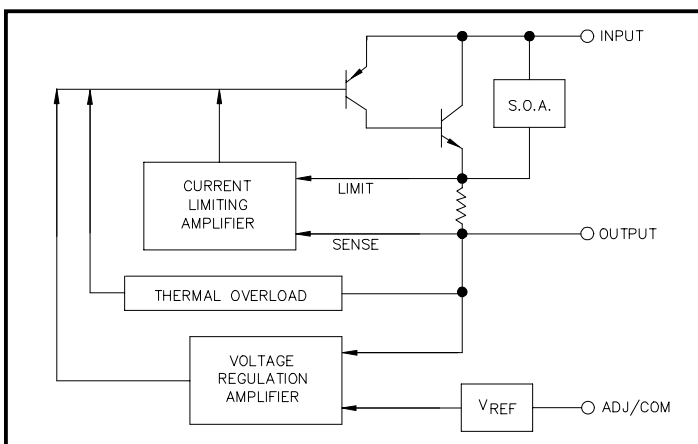

POWER MANAGEMENT

Outline Drawing - TO-220

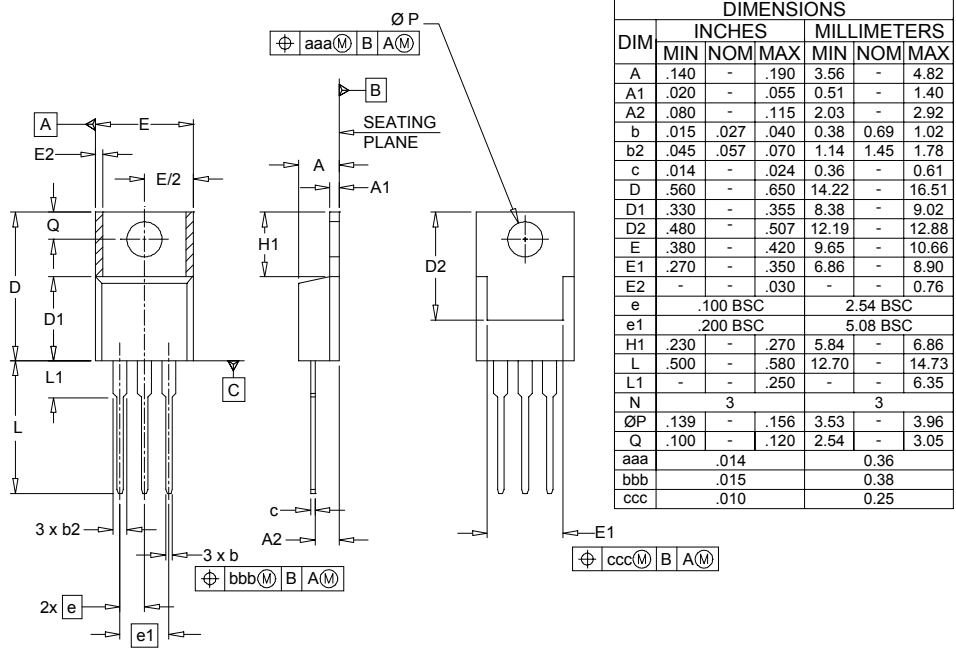

| DIM | INCHES | | | MILLIMETERS | | |
|-----|----------|------|------|-------------|------|-------|
| | MIN | NOM | MAX | MIN | NOM | MAX |
| A | .140 | - | .190 | 3.56 | - | 4.82 |
| A1 | .020 | - | .055 | 0.51 | - | 1.40 |
| A2 | .080 | - | .115 | 2.03 | - | 2.92 |
| b | .015 | .027 | .040 | 0.38 | 0.69 | 1.02 |
| b2 | .045 | .057 | .070 | 1.14 | 1.45 | 1.78 |
| c | .014 | - | .024 | 0.36 | - | 0.61 |
| D | .560 | - | .650 | 14.22 | - | 16.51 |
| D1 | .330 | - | .355 | 8.38 | - | 9.02 |
| D2 | .480 | - | .507 | 12.19 | - | 12.88 |
| E | .380 | - | .420 | 9.65 | - | 10.66 |
| E1 | .270 | - | .350 | 6.86 | - | 8.90 |
| E2 | - | - | .030 | - | - | 0.76 |
| e | .100 BSC | | | 2.54 BSC | | |
| e1 | .200 BSC | | | 5.08 BSC | | |
| H1 | .230 | - | .270 | 5.84 | - | 6.86 |
| L | .500 | - | .580 | 12.70 | - | 14.73 |
| L1 | - | - | .250 | - | - | 6.35 |
| N | 3 | | | 3 | | |
| ØP | .139 | - | .156 | 3.53 | - | 3.96 |
| Q | .100 | - | .120 | 2.54 | - | 3.05 |
| aaa | .014 | | | 0.36 | | |
| bbb | .015 | | | 0.38 | | |
| ccc | .010 | | | 0.25 | | |

- NOTES:
1. CONTROLLING DIMENSIONS ARE IN INCHES.
 2. DIMENSIONS "D" AND "E" DO NOT INCLUDE MOLD FLASH, PROTRUSIONS OR GATE BURRS.

Outline Drawing - TO-263

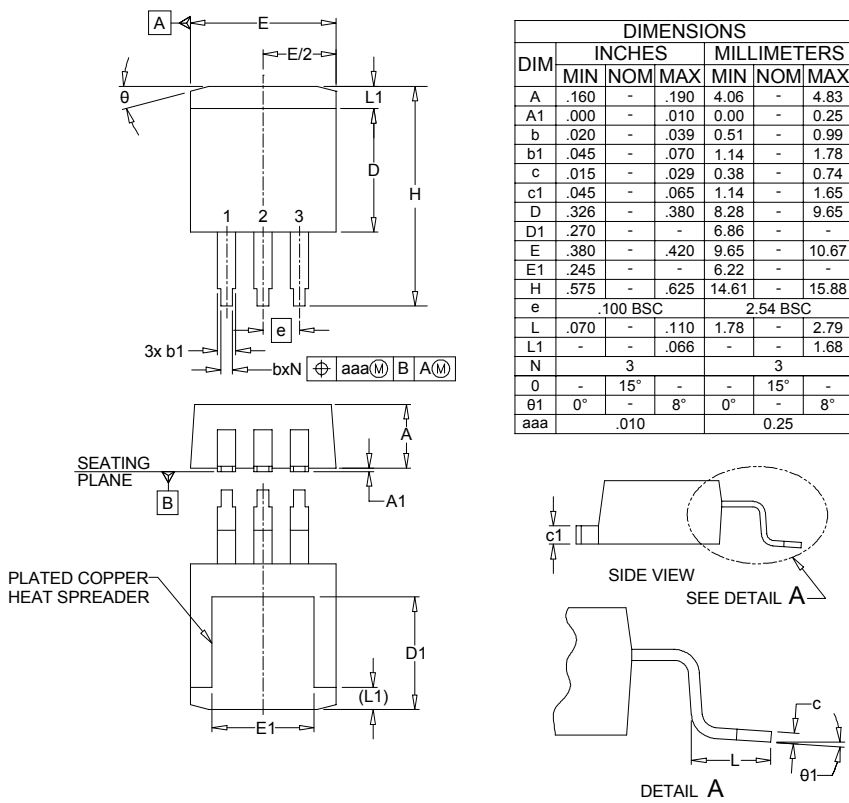

| DIM | INCHES | | | MILLIMETERS | | |
|-----|----------|-----|------|-------------|-----|-------|
| | MIN | NOM | MAX | MIN | NOM | MAX |
| A | .160 | - | .190 | 4.06 | - | 4.83 |
| A1 | .000 | - | .010 | 0.00 | - | 0.25 |
| b | .020 | - | .039 | 0.51 | - | 0.99 |
| b1 | .045 | - | .070 | 1.14 | - | 1.78 |
| c | .015 | - | .029 | 0.38 | - | 0.74 |
| c1 | .045 | - | .065 | 1.14 | - | 1.65 |
| D | .326 | - | .380 | 8.28 | - | 9.65 |
| D1 | .270 | - | - | 6.86 | - | - |
| E | .380 | - | .420 | 9.65 | - | 10.67 |
| E1 | .245 | - | - | 6.22 | - | - |
| H | .575 | - | .625 | 14.61 | - | 15.88 |
| e | .100 BSC | | | 2.54 BSC | | |
| L | .070 | - | .110 | 1.78 | - | 2.79 |
| L1 | - | - | .066 | - | - | 1.68 |
| N | 3 | | | 3 | | |
| Ø | - | 15° | - | - | 15° | - |
| Ø1 | 0° | - | 8° | 0° | - | 8° |
| aaa | .010 | | | 0.25 | | |

- NOTES:
1. CONTROLLING DIMENSIONS ARE IN INCHES (ANGLES IN DEGREES).
 2. DIMENSIONS "D" AND "E" DO NOT INCLUDE MOLD FLASH, PROTRUSIONS OR GATE BURRS.

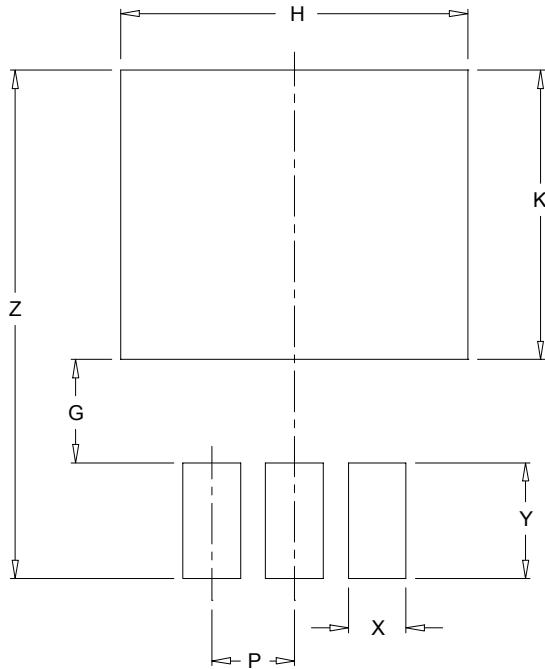
POWER MANAGEMENT
Land Pattern - T0-263

| DIMENSIONS | | |
|------------|--------|-------------|
| DIM | INCHES | MILLIMETERS |
| G | .125 | 3.17 |
| H | .420 | 10.67 |
| K | .350 | 8.89 |
| P | .100 | 2.54 |
| X | .070 | 1.78 |
| Y | .140 | 3.56 |
| Z | .615 | 15.62 |

NOTES:

1. THIS LAND PATTERN IS FOR REFERENCE PURPOSES ONLY
CONSULT YOUR MANUFACTURING GROUP TO ENSURE YOUR
COMPANY'S MANUFACTURING GUIDELINES ARE MET.

Contact Information

Semtech Corporation
 Power Management Products Division
 200 Flynn Road, Camarillo, CA 93012
 Phone: (805)498-2111 FAX (805)498-3804