

Ceramic Resonators, Chip Type (2 Array Type)

Type: **EFOP**

Type: **EFOD**

Type: **EFOPS**

Type: **EFOPM**

Type: **EFODM**

Type: **EFOLM**



■ Features

- Encased in a ceramic package
- High reliability against soldering heat and mechanical stress
- Moisture-proof sealing
- 1.2 mm maximum in thickness (PS/PM/DM/LM)
- Designed for reflow soldering
- Flat-bottom plate for better mounting
- RoHS compliant

■ Recommended Applications

- Clock generator for microprocessors
- Carrier circuit between telecommunication equipment (Telephone to telephone, personal computer to printer)

■ Handling Precautions (See Page 175 to 176)

■ Packaging Specifications

See Page 174, 177

■ Explanation of Part Numbers

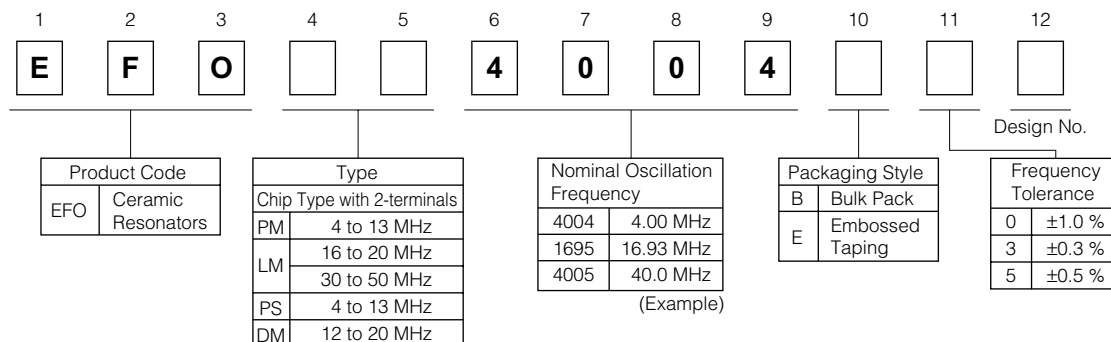
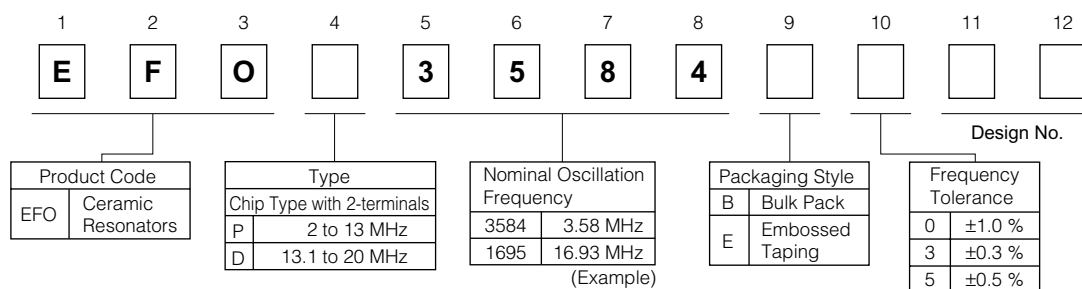

Part Number	Frequency range (MHz)	Frequency Temperature Characteristics (-20 to +80 °C)	Attached Capacitors (Reference)
EFOP	2.00 to 8.39	±0.3 %	33 pF
	8.40 to 13.0	±1.0 %	
EFOD	13.1 to 20.0	±1.0 %	33 pF
EFOPS	4.00 to 8.39	±0.6 %	21 pF
	8.40 to 13.0	±1.0 %	
EFOPM	4.00 to 8.39	±0.3 %	33 pF
	8.40 to 13.0	±1.0 %	
EFODM	12.0 to 20.0	±1.0 %	18 pF
EFOLM	16.0 to 20.0	±1.0 %	10 pF
	30.0 to 50.0	±0.3 %	

Design and specifications are each subject to change without notice. Ask factory for the current technical specifications before purchase and/or use. Should a safety concern arise regarding this product, please be sure to contact us immediately.

■ Dimensions in mm (not to scale)

Recommended Land Dimensions

[Type EFOP].....2.0 to 13.0 MHz

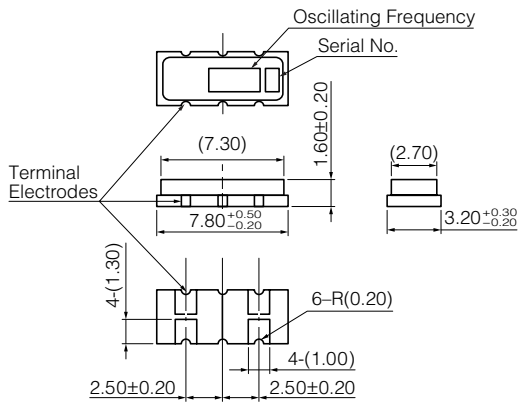

[Type EFOP, EFOPM]

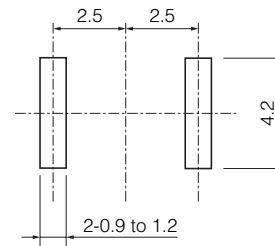

[Type EFOPM].....4.0 to 13.0 MHz

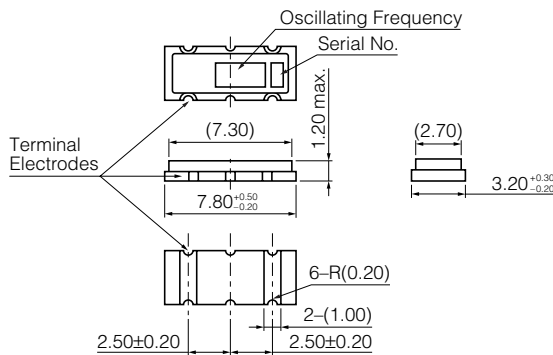

[Type EFOPS].....4.0 to 13.0 MHz

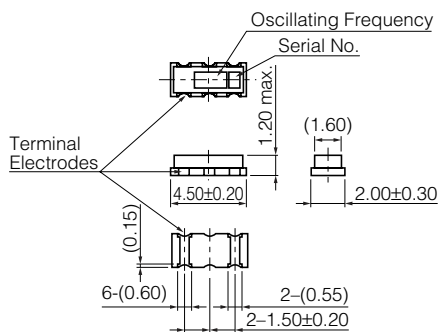

[Type EFOPS]

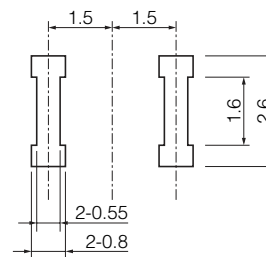

[Type EFOD].....13.1 to 20.0 MHz

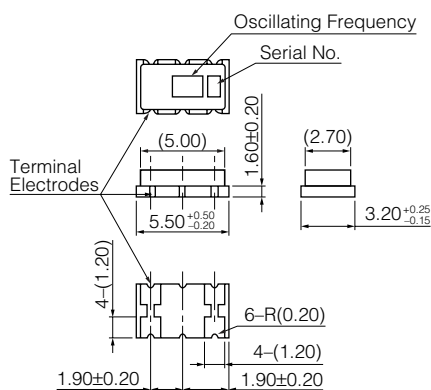

[Type EFOD]

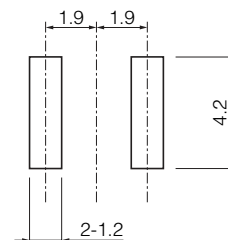

■ Dimensions in mm (not to scale)

Recommended Land Dimensions

[Type EFODM].....12.0 to 20.0MHz

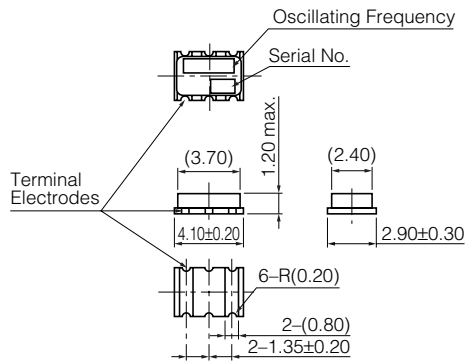

[Type EFODM]

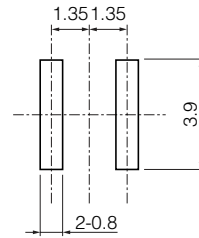

[Type EFOLM].....16.0 to 20.0, 30.0 to 50.0 MHz

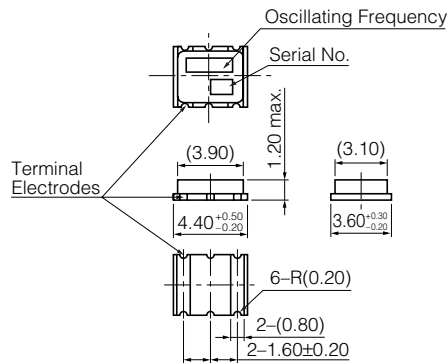

[Type EFOLM]

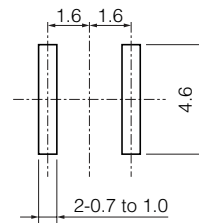

■ Test Circuits Diagram

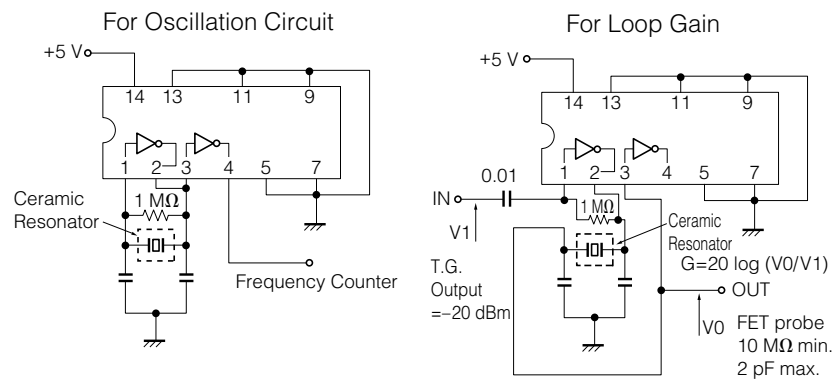

Frequency	IC
2.00 to 8.39 MHz	μPD4069UBC, TC4069UBP or similar
8.40 to 50.0 MHz	μPD74HCU, TC74HCU04AP or similar

■ Typical Characteristics Temperature Characteristics

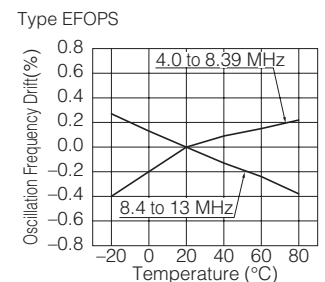
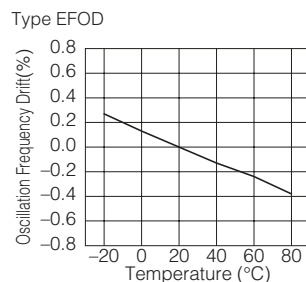
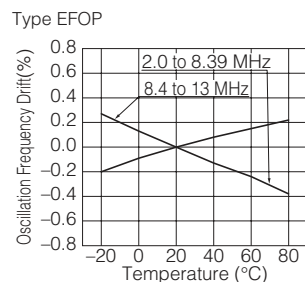

Design and specifications are each subject to change without notice. Ask factory for the current technical specifications before purchase and/or use. Should a safety concern arise regarding this product, please be sure to contact us immediately.

Typical Characteristics Temperature Characteristics

Type EFOPM

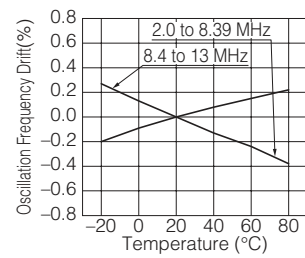

Type EFODM

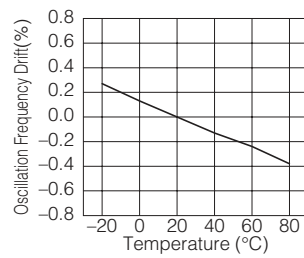

Type EFOLM

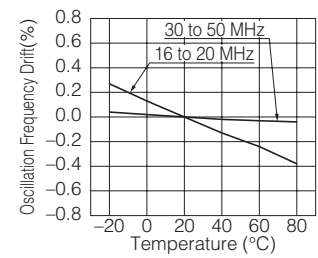

Packaging Specifications

Supplied in bulk or taped & reel packing style

Standard Packing Quantity

Type	Embossed Taping	Bulk
EFOP, EFOPM	2500 pcs./reel	500 pcs./bag
EFOPS	2000 pcs./reel	
EFOD, EFODM, EFOLM	1000 pcs./reel	

Dimensions for Reel in mm (not to scale)

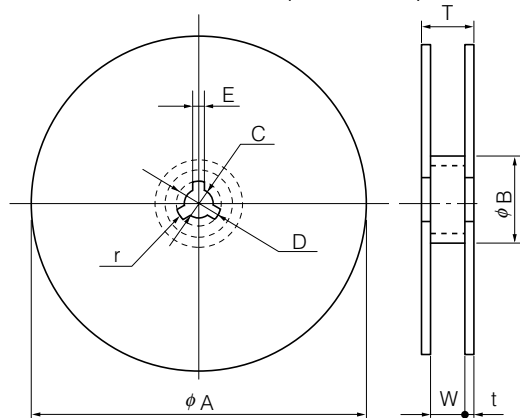

[Type EFOP, EFOPM]

Dim. (mm)	ϕA	ϕB	C	D	E
	330±5	80 min.	13.0±0.5	21.0±0.8	2.0±0.5
Dim. (mm)	W	T	t	r	
	16.4 ^{+2.0} ₀	22.4 max.	3 max.	1.0	

[Type EFOPS, EFOD, EDODM, EFOLM]

Dim. (mm)	ϕA	ϕB	C	D	E
	180±5	60 min.	13.0±0.5	21.0±0.8	2.0±0.5
Dim. (mm)	W	T	t	r	
	12.4 ^{+2.0} ₀	18.4 max.	3 max.	1.0	

Embossed Taping

[Type EFOP, EFOPM]

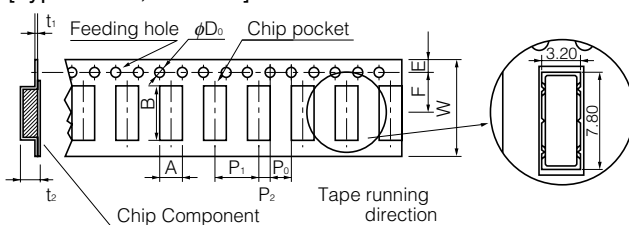

Dim. (mm)	A	B	W	F	E	P ₁
	3.7±0.2	8.3±0.2	16.0±0.3	7.5±0.1	1.75±0.10	8.0±0.1
Dim. (mm)	P ₂	P ₀	ϕD_0	t ₁	t ₂	
	2.0±0.1	4.0±0.1	1.5 ^{+0.1} ₀	0.3	3.5 max.	

[Type EFOPS]

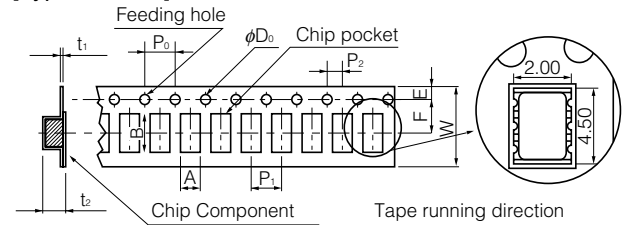

Dim. (mm)	A	B	W	F	E	P ₁
	2.6±0.2	5.1±0.2	12.0±0.3	5.5±0.1	1.75±0.10	4.0±0.1
Dim. (mm)	P ₂	P ₀	ϕD_0	t ₁	t ₂	
	2.0±0.1	4.0±0.1	1.5 ^{+0.1} ₀	0.6 max.	3.0 max.	

[Type EFOD, EFODM, EFOLM]

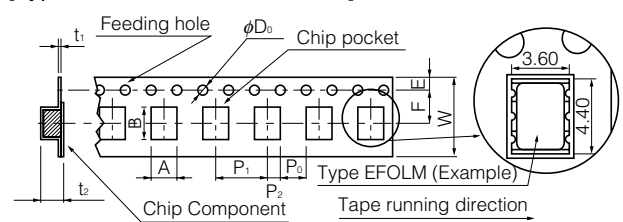

Dim. (mm)	A	B	W	F	E	P ₁
	①	②	12.0±0.3	5.5±0.1	1.75±0.10	8.0±0.1
Dim. (mm)	P ₂	P ₀	ϕD_0	t ₁	t ₂	
	2.0±0.1	4.0±0.1	1.5 ^{+0.1} ₀	0.6 max.	3.0 max.	

Dim. (mm)	A	B
	①	②
Type EFOD	3.7±0.2	6.0±0.2
Type EFODM	3.4±0.2	4.6±0.2
Type EFOLM	4.1±0.2	4.9±0.2

Design and specifications are each subject to change without notice. Ask factory for the current technical specifications before purchase and/or use. Should a safety concern arise regarding this product, please be sure to contact us immediately.