

THIS DRAWING IS UNPUBLISHED. RELEASED FOR PUBLICATION  
 © COPYRIGHT - By - ALL RIGHTS RESERVED.

LOC	DIST	REVISIONS					
AJ	16	P	LTR	DESCRIPTION	DATE	DWN	APVD
		R2		ECO-15-007090	27APR15	LL	SH

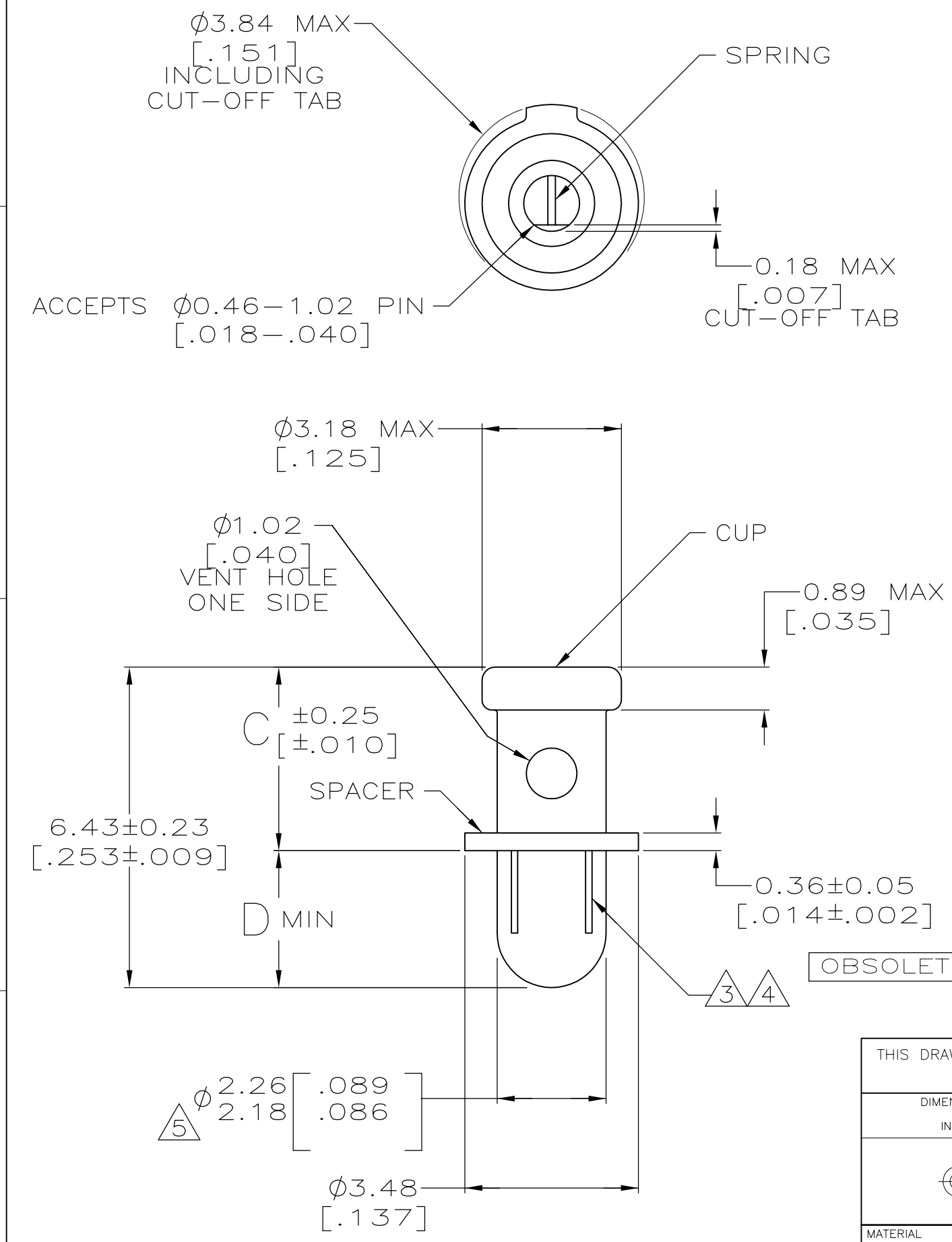

- ① CUP: COPPER.  
SPACER: BRASS.  
SPRING: BERYLLIUM COPPER.
- ② CUP: 2.54µm [.000100] MIN TIN-LEAD.  
SPACER: 2.03µm [.000080] MIN TIN-LEAD OVER  
1.27µm [.000050] MIN NICKEL.  
SPRING: GOLD FLASH OVER 1.27µm [.000050] MIN NICKEL.  
0.76µm [.000030] MIN GOLD IN CONTACT AREA.
- ③ 4 BARE LINES 90° APART ON OUTSIDE OF CUP.
- ④ Ø2.11 [.083] MIN ACROSS BARE METAL.
- ⑤ FITS INTO Ø2.261±0.038 [.0890±.0015] HOLE,  
FOR HAND INSERTION.
- 6. 3.68 [.145] MIN INSERTION DEPTH FOR RELIABLE CONTACT  
OF COMPONENT LEAD.
- 7. AFTER SIZING WITH PIN "A", SAME PART MUST MEET  
EXTRACTION FORCE WITH PIN "B".

PIN "A" DIA	MAX INSERTION FORCE GRAMS [OUNCES]	PIN "B" DIA	MIN EXTRACTION FORCE GRAMS [OUNCES]
0.51 [.020]	482 [17]	0.46 [.018]	28.3 [1.0]
0.81 [.032]	1049 [37]	0.64 [.025]	42.5 [1.5]
1.02 [.040]	1361 [48]	0.89 [.035]	56.7 [2.0]

- ⑧ SUPERSEDED BY 1-380737-0.
- ⑨ CUP: 7.62µm [.000300] MIN MATTE TIN-LEAD OVER  
1.27µm [.000050] MIN NICKEL.  
SPACER: 7.62µm [.000300] MIN MATTE TIN-LEAD OVER  
1.27µm [.000050] MIN NICKEL.  
SPRING: GOLD FLASH OVER 1.27µm [.000050] MIN NICKEL.  
0.76µm [.000030] MIN GOLD IN CONTACT AREA.

NONE	⑨	2.16 [.085]	3.68 [.145]	2-380737-0
AS SHOWN	②	2.90 [.114]	3.05 [.120]	1-380737-1 ⑧
OBSOLETE AS SHOWN	②	2.16 [.085]	3.68 [.145]	1-380737-0
VENT HOLE	PLATING	D	C	PART NUMBER

THIS DRAWING IS A CONTROLLED DOCUMENT.		DWN D.HARDY 22 DEC 99	<b>STE</b> TE Connectivity	
DIMENSIONS: INCHES		CHK H.WYNKOOP 19 JAN 00		
TOLERANCES UNLESS OTHERWISE SPECIFIED:		APVD H.WYNKOOP 19 JAN 00	NAME	
0 PLC ± -	1 PLC ± -	PRODUCT SPEC	RECEPTACLE ASSEMBLY, REUSABLE COMPONENT	
2 PLC ± 0.38 [.015]	3 PLC ± -	APPLICATION SPEC	SIZE	CAGE CODE
4 PLC ± -	ANGLES ± 1°	FINISH	DRAWING NO	RESTRICTED TO
MATERIAL ①	FINISH ②	WEIGHT -	A3 00779	C-380737
CUSTOMER DRAWING			SCALE 10:1	SHEET 1 of 1
			REV R2	