

LOC	DIST	P	F	ZONE	LTR	DESCRIPTION	DATE	APPD
FT	47				F	ADDED -2 PER NPR 4692	04/15/93	GS
					G	REV PER EC 0320-137-97	7-29-97	PB
					G1	REVISED PER ECO-09-020689	27AUG09	AEG

1. WIRE RANGE 26-20 AWG.
2. COLOR CODED YELLOW IN SPRING DIMPLE AREA.
3. 0.76 μ m [.000030] MIN GOLD PER MIL-G-45204 ON MATING END FOR A LENGTH OF 5.08 [.200] MIN WITH A UNIFORM GRADIENT TO 0.25 μ m [.000010] MIN GOLD PER MIL-G-45204 ON INSULATION SUPPORT BARREL OVER 0.76 μ m [.000030] MIN NICKEL PER QQ-N-290.
4. OBSOLETE PARTS: OBSOLETE CIS STREAMLINING PER D.RENAUD/D.SINISI

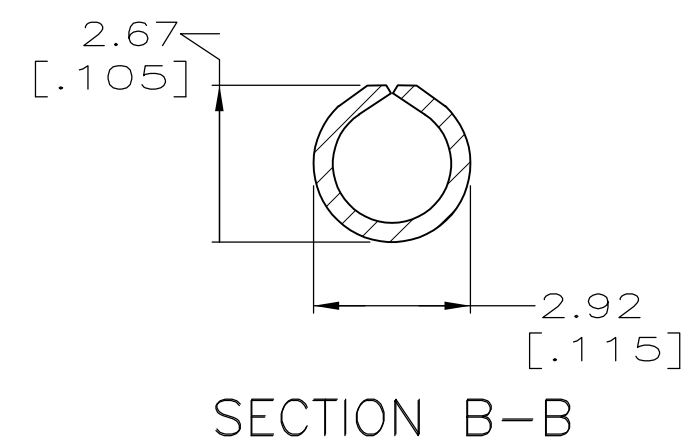
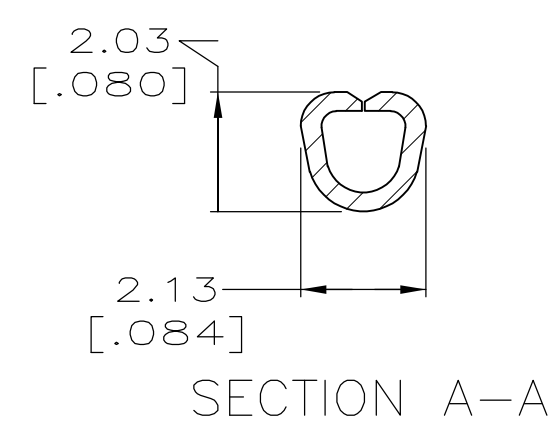
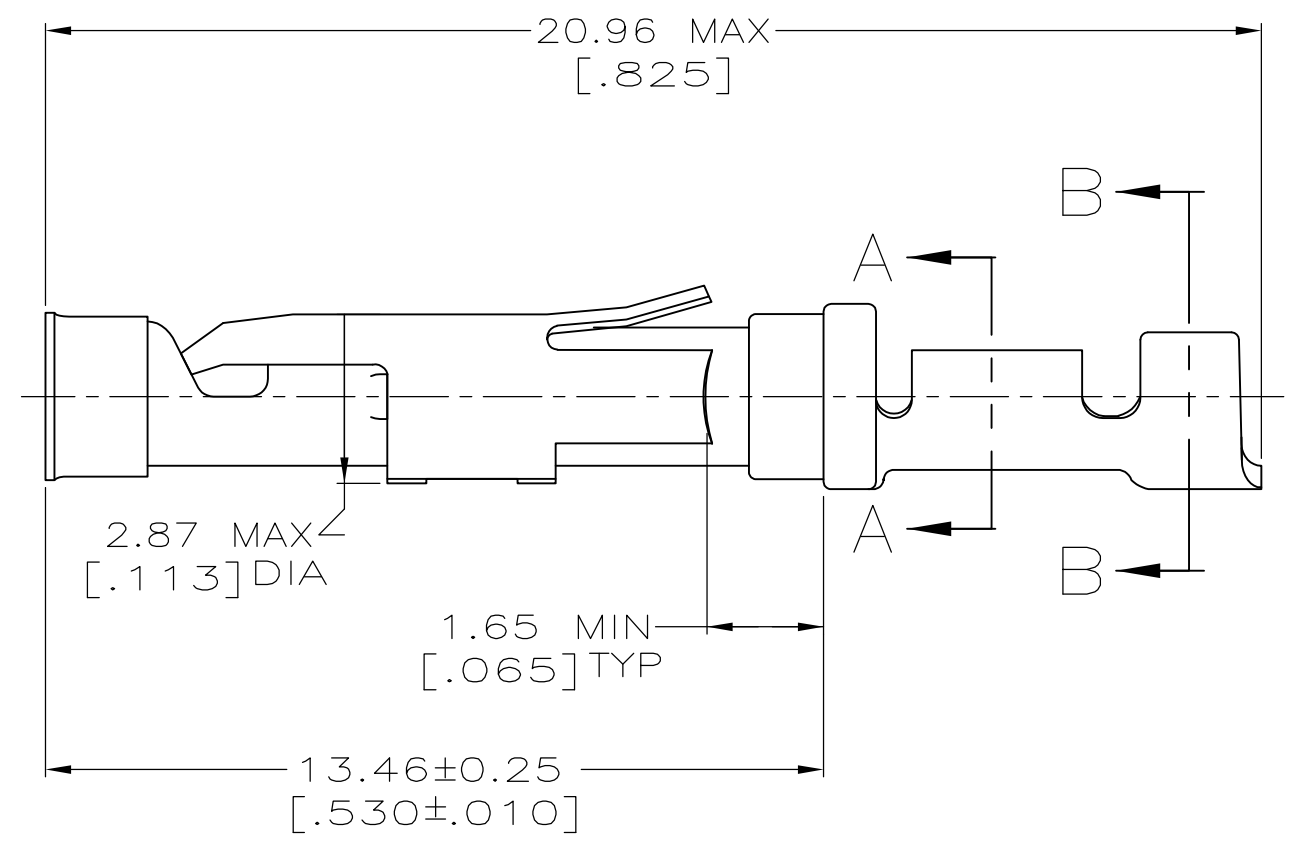
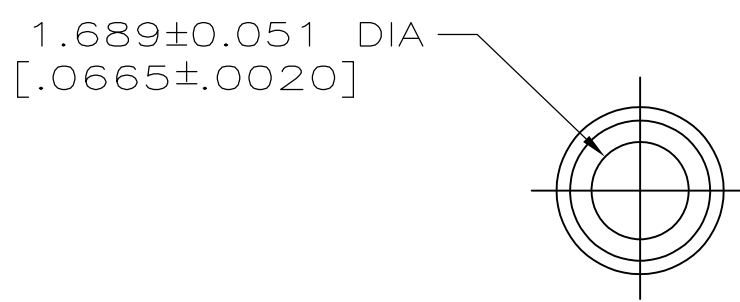
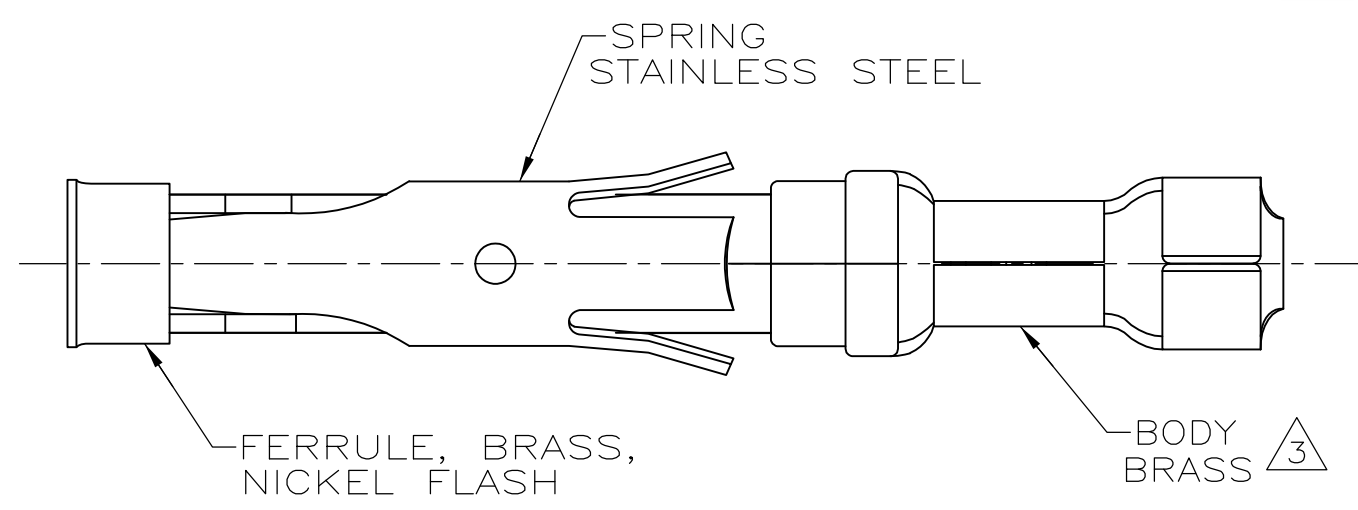

4 OBSOLETE	SMALL PACK	66183-2
	STANDARD	66183-1
	PACKAGING TYPE	PART NO

DO NOT SCALE PRINT. UNLESS SPECIFIED DIMENSIONS IN mm [INCHES] TOLERANCES ON: 2 PLC DEC ± 0.13 [.005] 3 PLC DEC ± - ANGLES ± -	DR 7-30-91 R.SHIREY	AMP Incorporated Harrisburg, PA 17105-3608	
	CHK 9-19-91 R.STONE		
MATERIAL	APPD 9-20-91 J.WESTMAN	NAME	
SEE CALLOUTS	APPD 9-23-91 W.PARKER	SOCKET ASSEMBLY, LOOSE PIECE, TYPE III+	
FINISH	APPLICATION SPEC	SIZE	CAGE CODE
SEE CALLOUTS	-	C	00779
	WEIGHT	SCALE	DRAWING NO
	-	8:1	66183
			SHEET 1 OF 1