



Isolated Drive Transmitter

FEATURES

- 750mA Output Drive, Source or Sink
- 8 to 35V Operation
- Transmits Drive Logic and Power through Low Cost Transformer
- Programmable Operating Frequency
- Up to 750kHz Operation
- Improved Output Control Algorithm Minimizes Output Jitter
- Fault Logic Monitors Isolated High Side IGBT Driver UC1727 for Faults
- User Programmable Fault Timing Screens False Fault Signals
- Shutdown Mode Disables On Chip Logic Reference for Low Standby Power
- Optional External Biasing of Logic Circuitry can Reduce Overall Power Dissipation

DESCRIPTION

The UC1726 Isolated Drive Transmitter, and its companion chip, the UC1727 Isolated High Side IGBT Driver, provide a unique solution to driving isolated power IGBTs. They are particularly suited to drive the high side devices on a high voltage H-bridge. The UC1726 device transmits the drive logic and drive power, along with transferring and receiving fault information with the isolated gate circuit using a low cost pulse transformer.

This drive system utilizes a duty cycle modulation technique that gives instantaneous response to the drive control transitions, and reliably passes steady state, or DC conditions. High frequency operation, up to 750kHz, allows the cost and size of the coupling transformer to be minimized.

The UC1726 can be powered from a single Vcc supply which internally generates a voltage reference for the logic circuitry. It can also be placed into a low power shutdown mode that disables the internal reference. The IC's logic circuitry can be powered from an external supply, VL, to minimize overall power dissipation. Fault logic monitors the Isolated High Side IGBT Driver UC1727 for faults. Based on user defined timing, the UC1726 distinguishes valid faults, which it responds to by setting the fault latch pin. This also disables the gate drive information until the fault reset pin is toggled to a logic one.

The UC1726 operates over an 8 to 35 volt supply range. The typical Vcc voltage will be greater than 28 volts to be compatible with the UC1727. The undervoltage lockout circuitry of the Isolated High Side IGBT Driver UC1727 locks out the drive information during its undervoltage lockout.

BLOCK DIAGRAM

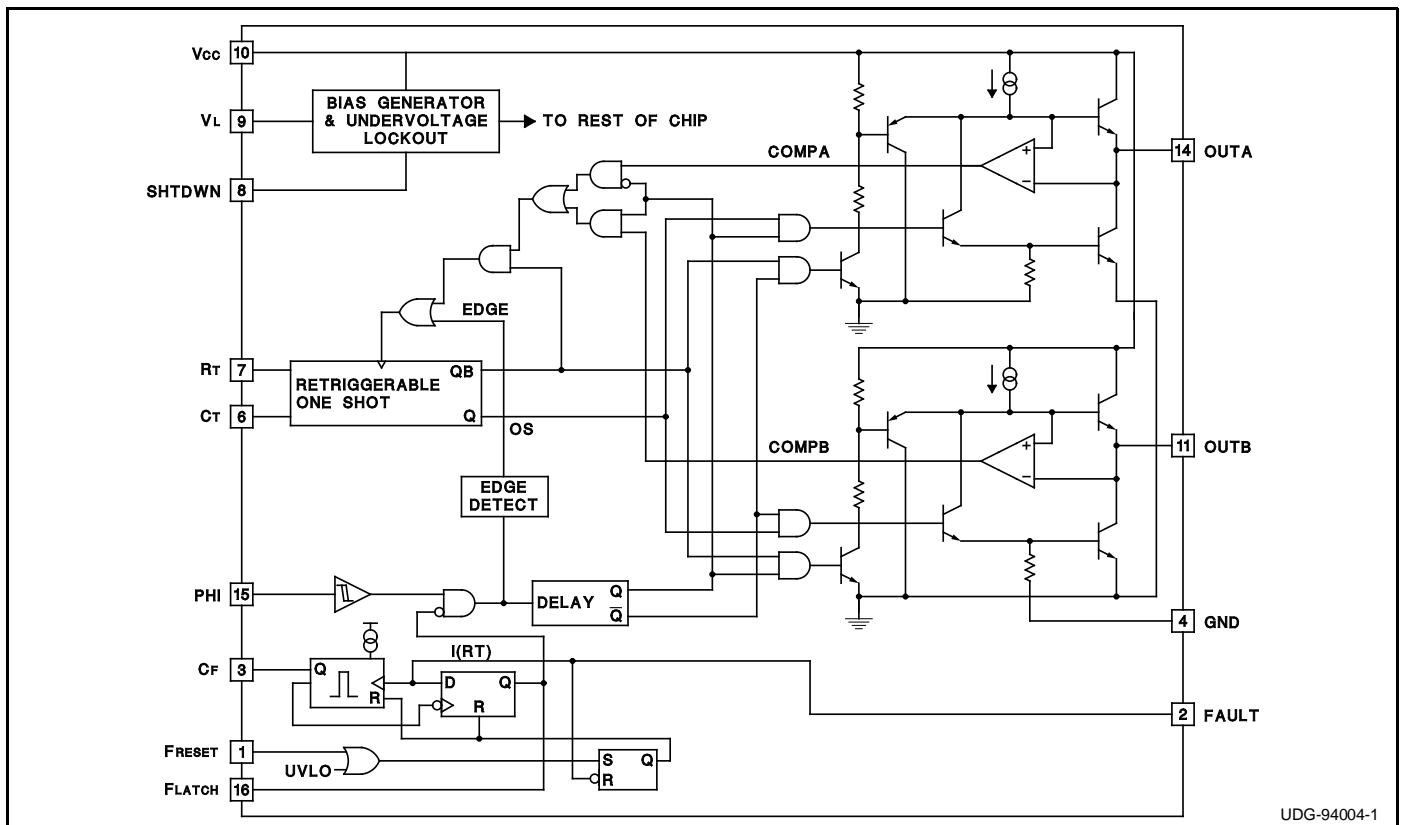

UDG-94004-1

ABSOLUTE MAXIMUM RATINGS

Supply Voltage Vcc 40V
 Source/Sink Current (Pulsed) 1.5A
 Source/Sink Current (Continuous) 1.0A
 Output Voltage (pins 12, 14) -0.3 to (Vcc + 0.3)V
 CF, FRESET, FAULT, SHTDWN,
 FLATCH, VL, PHI, RT -0.3 to 6.0V
 CT 1.0 to 6.0V
 Operating Junction Temperature (Note 2) 150°C
 Storage Temperature Range -65°C to 150°C
 Lead Temperature (Soldering, 10 seconds) 300°C

Note 1: All voltages are with respect to GND (Pin 2); all currents are positive into, negative out of part.

RECOMMENDED OPERATING CONDITIONS (Note 3)

Input Voltage +9 to +35.0V
 Sink/Source Current (each output) 0 to 750mA
 Timing Resistor 2.4k to 200kΩ
 Timing Capacitor (CT) 75pF to 2.0nF
 Timing Capacitor (CF) 75pF to 3.0nF

Note 2: See Unitorde Integrated Circuits databook for information regarding thermal specifications and limitations of packages.

Note 3: Range over which the device is functional and parameter limits are guaranteed.

CONNECTION DIAGRAMS

**DIL-16 (Top View)
N Package**

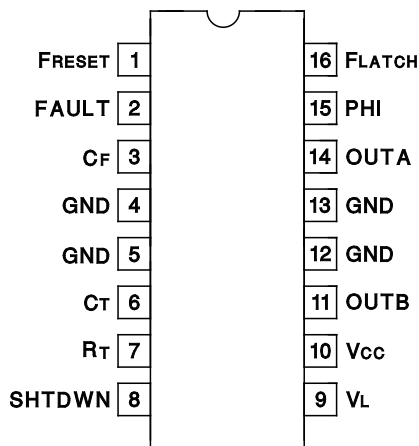

**DIL-16 (Top View)
SP Package**

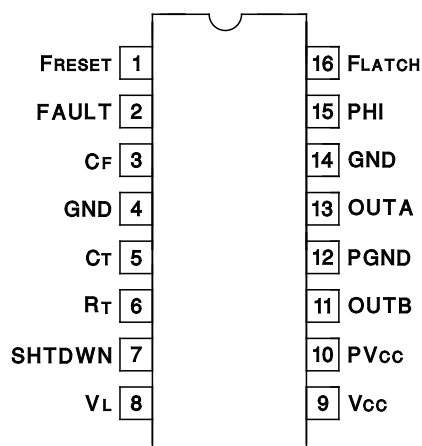

**DIL-18 (Top View)
J Package**

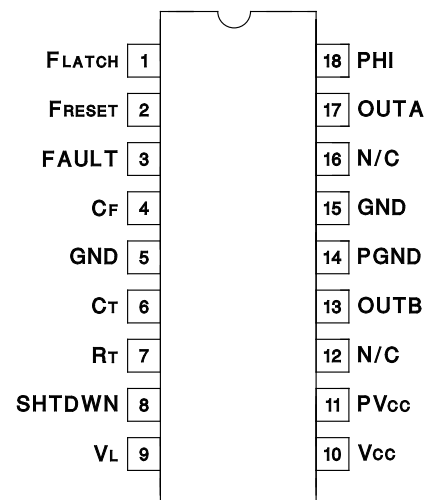

**SOIC-28 (Top View)
DWP Package**

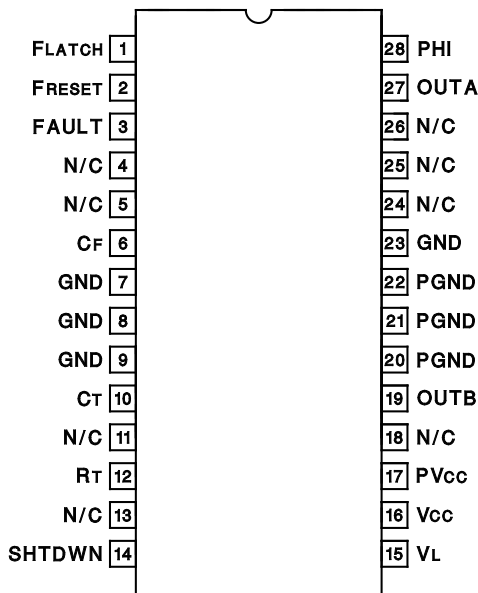

**PLCC-28 (Top View)
QP Package**

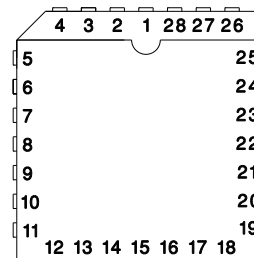

PACKAGE PIN FUNCTION	
FUNCTION	PIN
GND	1
CT	2
N/C	3-4
RT	5
SHTDWN	6
VL	7
Vcc	8
N/C	9
PVcc	10
OUTB	11
PGND	12-18
GND	19
OUTA	20
PHI	21
FLATCH	22
FRESET	23
FAULT	24
N/C	25
CF	26
N/C	27
N/C	28

ELECTRICAL CHARACTERISTICS: Unless otherwise stated, $V_{CC} = 20V$, $R_T = 4.32k\Omega$, $C_T = 330pF$ and $C_F = 2.2nF$, no load on any output, and $-55^\circ C < T_A < 125^\circ C$ for the UC1726, $-40^\circ C < T_A < 85^\circ C$ for the UC2726, and $0^\circ C < T_A < 70^\circ C$ for the UC3726, $T_A = T_J$.

PARAMETERS	TEST CONDITIONS	MIN	TYP	MAX	UNITS
Retriggerable one shot					
Initial Accuracy	$T_J = 25^\circ C$	1.400	1.600	1.800	μsec
Temperature Stability	Over operating T_J	1.000		2.200	μsec
Voltage Stability	$V_{CC} = 10$ to $35V$		0.2		$\% / V$
Operating Frequency	$L_{LOAD} = 1.5mH$		170		kHz
PHI Input (Control Input)					
HIGH Input Voltage		2.0			V
LOW Input Voltage				0.8	V
HIGH Input Current			10		μA
LOW Input Current			-300	-600	μA
Delay to one shot			100	250	nsec
Delay to Output	$C_T = 1.4V$		250		nsec
Output Drivers					
Output Low Level	$I_{SINK} = 20mA$		0.3	0.5	V
	$I_{SINK} = 400mA$		0.5	2.6	V
Output High Level (volts below V_{CC})	$I_{SOURCE} = -20mA$		2.0	2.6	V
	$I_{SOURCE} = -400mA$		2.0	2.9	V
Rise and Fall Times	No load		30	60	nsec
Logic Voltage Reference					
V_L - Logic Voltage	Internal Voltage	4.20	4.40	4.60	V
Logic Supply Current	$V_L = 4.75V$ to $5.25V$, $C_T = 1.4V$		13.0	20.0	mA
Shut Down Circuit					
Logic Voltage - Off			0.5		V
High Input Current	$V_{IH} = 2.4$			-100	μA
Low Input Current	$V_{IL} = 0.4$			-20	μA
Fault Logic					
Fault Reset High Input Current	$V_{IH} = 2.4$			± 5	μA
Fault Reset Low Input Current	$V_{IL} = 0.4$			-10	μA
Fault High Input Current	$V_{IH} = 2.4$			± 5	μA
Fault Low Input Current	$V_{IL} = 0.4$			-60	μA
Fault Pulse Width	$C_F = 330pF$		3.0		μs
	$C_F = 2.2nF$		17.0		μs
Fault Latch, V_{OH}	$I_{LOAD} = -1mA$, Volts below V_L		1.3	1.8	V
Fault Latch, V_{OL}	$I_{LOAD} = 1mA$		0.25	0.5	V
Fault Latch, V_{OH}	$I_{LOAD} = 0$, Volts below V_L		0.3		V
Fault Latch, V_{OL}	$I_{LOAD} = 0$		0.2		V
Fault Reset Pulse Width			500		ns
UVLO					
Turn On Threshold			7.1		V
Total Supply Current					
Supply Current	$C_T = 1.4V$		22	40	mA
	$C_T = 1.4V$, $V_L = 5.0V$		12	20	mA
	$C_T = 1.4V$, Shutdown = $5.0V$		2.5		mA

Refer to Typical Application on Page 5 and Application Note U-143A "New Chip Pair Provides Isolated Drive for High Voltage IGBTs"

PIN DESCRIPTIONS

CF: The timing input to the fault logic. A capacitor is placed across the input of CF and ground. The timing window is approximately $t = 2.1CFRT$.

CT: The connection to the timing capacitor that controls the operating frequency. A capacitor to ground is repetitively charged during the one shot pulse width. It is discharged when a comparator senses zero current in the primary side of the transformer. The one shot pulse width is consequently determined by the time it takes to charge the capacitor from a threshold voltage of $V_L/4$ to $V_L/2$. This pin must be tied to a capacitor. See Recommended Operating Conditions.

FAULT: This input to the fault logic initiates the user programmable timer. This time interval, specified by the capacitor on CF, determines the validity of the fault. The pin is tied to a low cost optocoupler, and is high until the UC1727 sends drive information from the PHI pin through the transformer while the FAULT pin stays low. Once this pin goes high, it must stay high during the entire fault window to be accepted as a valid fault. A valid fault sets the FLATCH pin high and prevents the transmitting of gate drive information until the FRESET is toggled high. If fault logic is not used, the FAULT pin must be grounded.

FLATCH: A valid fault sets this pin to a logic one and prevents the transmitting of gate drive information. The FLATCH pin can only be reset by connecting the FRESET to a logic 0.

FRESET: The input to the fault logic that resets the fault logic latch (FLATCH) and enables drive transmit data. This input must be low when powered up and stay low until after the fault latch has been set.

GND: The signal and power ground for the device. The power ground of the output transistor is isolated on the chip from the substrate ground which biases the remainder of the device.

OUTA: One output of the two totem pole outputs connected across the transformer primary winding. When PHI is high, the output toggles between 0.3V during the one shot charge time and approximately $V_{CC} + 0.4V$ during the remainder of the period. When PHI is low the output toggles between $V_{CC} - 2V$ during the one shot charge time and approximately $0.6V_{CC}$ during the remainder of the period.

OUTB: One output of the two totem pole outputs connected across the transformer primary winding. When PHI is high, the output toggles between $V_{CC} - 2V$ during the one shot charge time and approximately $0.6V_{CC}$ during the remainder of the period. When PHI is low the output toggles between 0.3V during the one shot charge time and approximately $V_{CC} + 0.4V$ during the remainder of the period.

PGND: This is the ground for the output transistors bonded in the 28 pin packages. On the sixteen pin packages it is bonded separately to the GND pin.

PHI: A logic control input to the isolated gate drive that changes the outputs as described above. This changes the duty cycle of the voltage wave form applied across the transformer. The Isolated High Side IGBT Driver UC1727 senses the different duty cycles as different drive commands.

PVcc: This is the input voltage for the output transistors on the 28 pin package. On the sixteen pin packages it is bonded separately to the Vcc pin.

RT: The input that sets the CT and CF capacitor currents with a resistor to ground. The voltage on RT is approximately $0.3V_L$. The resulting charge currents are: $IC_T = IC_F = V_L / 4RT$.

SHTDWN: This input shuts down the internal reference. A TTL logic one puts the UC1726 into a low standby current mode. This input has a pull down resistor on the chip to guarantee proper operation when left open. If an external logic voltage is applied to V_L , this shutdown feature cannot be used without bringing the external voltage source to zero volts.

Vcc: The input voltage that biases the outputs and the internal reference. It can vary between 8V to 35V. This supply pin will typically be greater than 28V to be compatible with the UC1727. In order to minimize power dissipation use an external logic supply, V_{CC} approximately 15V, and a step up transformer ($N = 2$).

VL: The logic supply pin that biases all circuits except for the totem pole outputs. A bypass capacitor is recommended on this pin when left unconnected. The internal reference is approximately 4.4V. A 5.0V supply can be applied to this pin to assure minimum power dissipation. When an external supply higher than the V_L voltage is applied to this pin, the internal reference turns off.

OPERATING FREQUENCY:

The chip operating frequency is determined by the values of components connected to the RT and CT pins. A resistor connected between RT and ground sets the charge current to $I_{CT} = V_L / 4R_T$. The operating frequency varies slightly depending on the VCC and VL voltages. The following equations approximate the one shot pulse width at operating frequency when VCC = 20V.

$$T_{PW} = 1.1R_T(C_T + 50pF)$$

$$F_O = \frac{1}{3.3R_T(C_T + 50pF)}$$

The 50pF additional capacity represents internal chip capacitance at the CT input.

TYPICAL APPLICATION

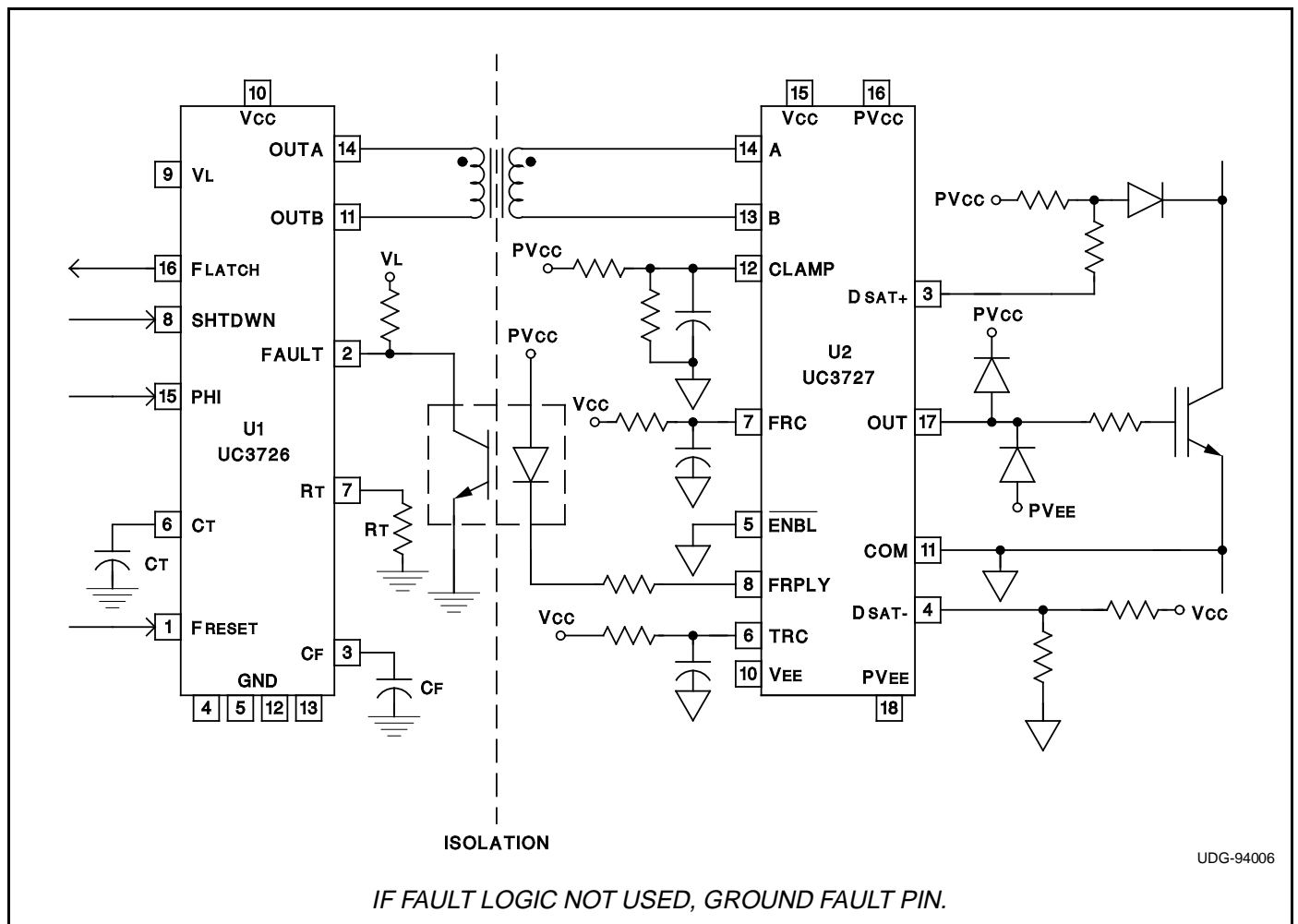

PACKAGING INFORMATION

Orderable Device	Status ⁽¹⁾	Package Type	Package Drawing	Pins	Package Qty	Eco Plan ⁽²⁾	Lead/Ball Finish	MSL Peak Temp ⁽³⁾
UC2726DWP	OBSOLETE	SOIC	DW	28		TBD	Call TI	Call TI
UC2726DWPTR	OBSOLETE	SOIC	DW	28		TBD	Call TI	Call TI
UC2726N	OBSOLETE	PDIP	N	16		TBD	Call TI	Call TI
UC3726DWP	OBSOLETE	SOIC	DW	16		TBD	Call TI	Call TI
UC3726DWPTR	OBSOLETE	SOIC	DW	16		TBD	Call TI	Call TI
UC3726N	OBSOLETE	PDIP	N	16		TBD	Call TI	Call TI

⁽¹⁾ The marketing status values are defined as follows:

ACTIVE: Product device recommended for new designs.

LIFEBUY: TI has announced that the device will be discontinued, and a lifetime-buy period is in effect.

NRND: Not recommended for new designs. Device is in production to support existing customers, but TI does not recommend using this part in a new design.

PREVIEW: Device has been announced but is not in production. Samples may or may not be available.

OBSOLETE: TI has discontinued the production of the device.

⁽²⁾ Eco Plan - The planned eco-friendly classification: Pb-Free (RoHS), Pb-Free (RoHS Exempt), or Green (RoHS & no Sb/Br) - please check <http://www.ti.com/productcontent> for the latest availability information and additional product content details.

TBD: The Pb-Free/Green conversion plan has not been defined.

Pb-Free (RoHS): TI's terms "Lead-Free" or "Pb-Free" mean semiconductor products that are compatible with the current RoHS requirements for all 6 substances, including the requirement that lead not exceed 0.1% by weight in homogeneous materials. Where designed to be soldered at high temperatures, TI Pb-Free products are suitable for use in specified lead-free processes.

Pb-Free (RoHS Exempt): This component has a RoHS exemption for either 1) lead-based flip-chip solder bumps used between the die and package, or 2) lead-based die adhesive used between the die and leadframe. The component is otherwise considered Pb-Free (RoHS compatible) as defined above.

Green (RoHS & no Sb/Br): TI defines "Green" to mean Pb-Free (RoHS compatible), and free of Bromine (Br) and Antimony (Sb) based flame retardants (Br or Sb do not exceed 0.1% by weight in homogeneous material)

⁽³⁾ MSL, Peak Temp. -- The Moisture Sensitivity Level rating according to the JEDEC industry standard classifications, and peak solder temperature.

Important Information and Disclaimer: The information provided on this page represents TI's knowledge and belief as of the date that it is provided. TI bases its knowledge and belief on information provided by third parties, and makes no representation or warranty as to the accuracy of such information. Efforts are underway to better integrate information from third parties. TI has taken and continues to take reasonable steps to provide representative and accurate information but may not have conducted destructive testing or chemical analysis on incoming materials and chemicals. TI and TI suppliers consider certain information to be proprietary, and thus CAS numbers and other limited information may not be available for release.

In no event shall TI's liability arising out of such information exceed the total purchase price of the TI part(s) at issue in this document sold by TI to Customer on an annual basis.

IMPORTANT NOTICE

Texas Instruments Incorporated and its subsidiaries (TI) reserve the right to make corrections, enhancements, improvements and other changes to its semiconductor products and services per JESD46C and to discontinue any product or service per JESD48B. Buyers should obtain the latest relevant information before placing orders and should verify that such information is current and complete. All semiconductor products (also referred to herein as "components") are sold subject to TI's terms and conditions of sale supplied at the time of order acknowledgment.

TI warrants performance of its components to the specifications applicable at the time of sale, in accordance with the warranty in TI's terms and conditions of sale of semiconductor products. Testing and other quality control techniques are used to the extent TI deems necessary to support this warranty. Except where mandated by applicable law, testing of all parameters of each component is not necessarily performed.

TI assumes no liability for applications assistance or the design of Buyers' products. Buyers are responsible for their products and applications using TI components. To minimize the risks associated with Buyers' products and applications, Buyers should provide adequate design and operating safeguards.

TI does not warrant or represent that any license, either express or implied, is granted under any patent right, copyright, mask work right, or other intellectual property right relating to any combination, machine, or process in which TI components or services are used. Information published by TI regarding third-party products or services does not constitute a license to use such products or services or a warranty or endorsement thereof. Use of such information may require a license from a third party under the patents or other intellectual property of the third party, or a license from TI under the patents or other intellectual property of TI.

Reproduction of significant portions of TI information in TI data books or data sheets is permissible only if reproduction is without alteration and is accompanied by all associated warranties, conditions, limitations, and notices. TI is not responsible or liable for such altered documentation. Information of third parties may be subject to additional restrictions.

Resale of TI components or services with statements different from or beyond the parameters stated by TI for that component or service voids all express and any implied warranties for the associated TI component or service and is an unfair and deceptive business practice. TI is not responsible or liable for any such statements.

Buyer acknowledges and agrees that it is solely responsible for compliance with all legal, regulatory and safety-related requirements concerning its products, and any use of TI components in its applications, notwithstanding any applications-related information or support that may be provided by TI. Buyer represents and agrees that it has all the necessary expertise to create and implement safeguards which anticipate dangerous consequences of failures, monitor failures and their consequences, lessen the likelihood of failures that might cause harm and take appropriate remedial actions. Buyer will fully indemnify TI and its representatives against any damages arising out of the use of any TI components in safety-critical applications.

In some cases, TI components may be promoted specifically to facilitate safety-related applications. With such components, TI's goal is to help enable customers to design and create their own end-product solutions that meet applicable functional safety standards and requirements. Nonetheless, such components are subject to these terms.

No TI components are authorized for use in FDA Class III (or similar life-critical medical equipment) unless authorized officers of the parties have executed a special agreement specifically governing such use.

Only those TI components which TI has specifically designated as military grade or "enhanced plastic" are designed and intended for use in military/aerospace applications or environments. Buyer acknowledges and agrees that any military or aerospace use of TI components which have **not** been so designated is solely at the Buyer's risk, and that Buyer is solely responsible for compliance with all legal and regulatory requirements in connection with such use.

TI has specifically designated certain components which meet ISO/TS16949 requirements, mainly for automotive use. Components which have not been so designated are neither designed nor intended for automotive use; and TI will not be responsible for any failure of such components to meet such requirements.

Products

Audio	www.ti.com/audio
Amplifiers	amplifier.ti.com
Data Converters	dataconverter.ti.com
DLP® Products	www.dlp.com
DSP	dsp.ti.com
Clocks and Timers	www.ti.com/clocks
Interface	interface.ti.com
Logic	logic.ti.com
Power Mgmt	power.ti.com
Microcontrollers	microcontroller.ti.com
RFID	www.ti-rfid.com
OMAP Mobile Processors	www.ti.com/omap
Wireless Connectivity	www.ti.com/wirelessconnectivity

Applications

Automotive and Transportation	www.ti.com/automotive
Communications and Telecom	www.ti.com/communications
Computers and Peripherals	www.ti.com/computers
Consumer Electronics	www.ti.com/consumer-apps
Energy and Lighting	www.ti.com/energy
Industrial	www.ti.com/industrial
Medical	www.ti.com/medical
Security	www.ti.com/security
Space, Avionics and Defense	www.ti.com/space-avionics-defense
Video and Imaging	www.ti.com/video

TI E2E Community e2e.ti.com