

10/100BASE-TX QUAD PORT TRANSFORMER MODULES

For Use with Level One's LXT974, LXT975 and LXT980 Series of PHY Solutions

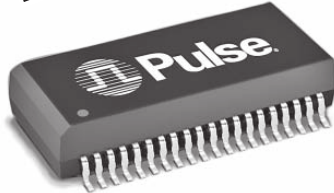

- RoHS peak reflow temperature rating: 245°C
- Meets IEEE 802.3 specification
- Models designed to support four single- or double-stacked RJ-45 connectors

Electrical Specifications @ 25°C — Operating Temperature 0°C to 70°C

Part Number ³	Insertion Loss (dB TYP)		Return Loss (dB TYP)				Crosstalk (dB TYP)				Common to Common Rejection Ratio 0.1-60 MHz (dB MIN)		Differential to Common Mode Rejection (dB MIN)	
	0.1-100 MHz	2-30 MHz	40 MHz	50 MHz	60-80 MHz	1 MHz	30 MHz	60 MHz	100 MHz	Transmit	Receive	1-60 MHz	60-200 MHz	
H1068NL ^{2d}	-0.5	-21	-17	-14.5	-12	-60	-50	-40	-35	-30	-30	-40	-30	
H1069NL ^{2d}	-0.5	-21	-17	-14.5	-12	-60	-50	-40	-35	-30	-30	-40	-30	
H1074NL ^{2d}	-0.5	-21	-17	-14.5	-12	-60	-50	-40	-30	-30	-30	-40	-30	

1. All products meet input/output breakdown (HiPot) of 1500 Vrms.
2. MSL=Moisture Sensitivity Level a=1 b=2 c=3 d=4

3. When ordering Tape & Reel packaging, add a "T" suffix to the end of the part number, e.g. H1068NLT

Mechanical

H10XXNL

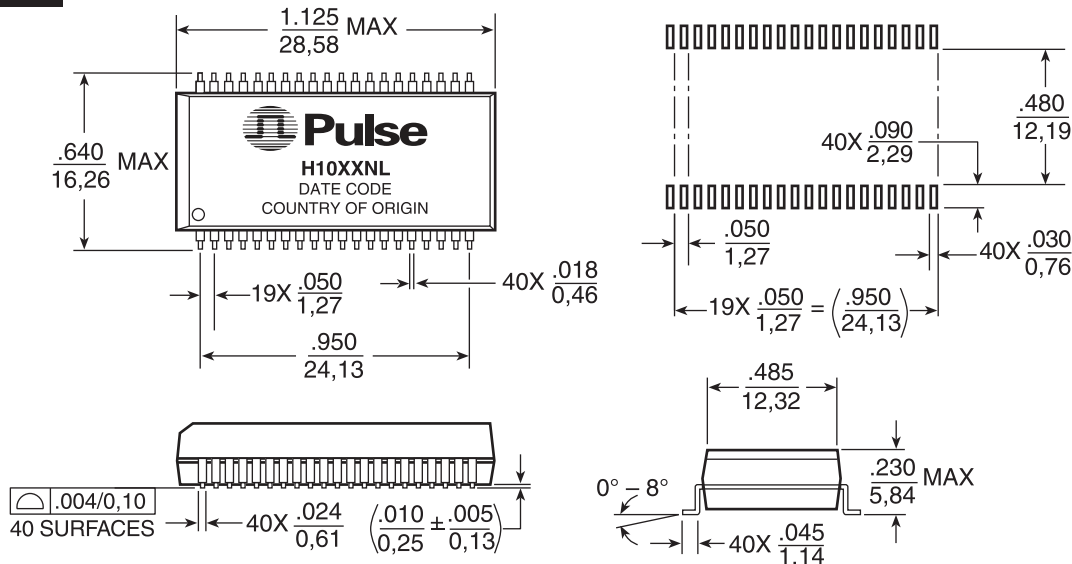

Dimensions: $\frac{\text{Inches}}{\text{mm}}$ Unless otherwise specified, all tolerances are $\frac{\pm .010}{0.25}$

10/100BASE-TX QUAD PORT TRANSFORMER MODULES

For Use with Level One's LXT974, LXT975 and LXT980 Series of PHY Solutions



Schematics

H1068NL

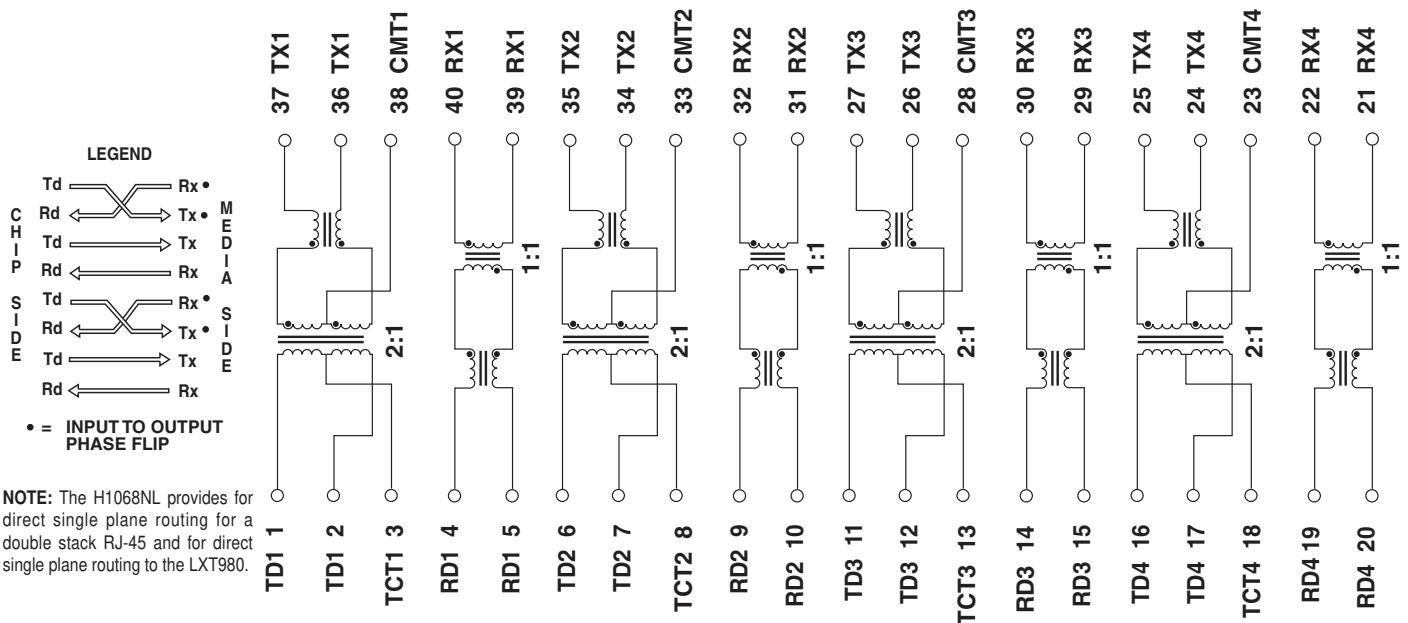

H1069NL

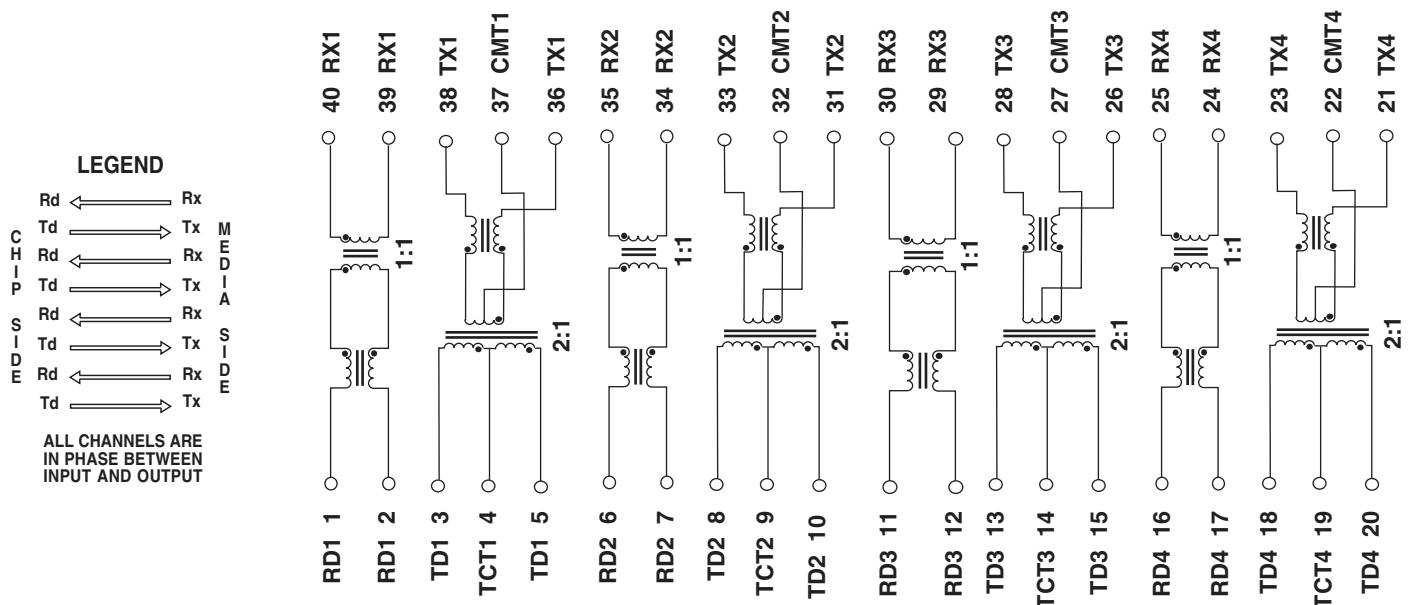

10/100BASE-TX QUAD PORT TRANSFORMER MODULES

For Use with Level One's LXT974, LXT975 and LXT980 Series of PHY Solutions



Schematic

H1074NL

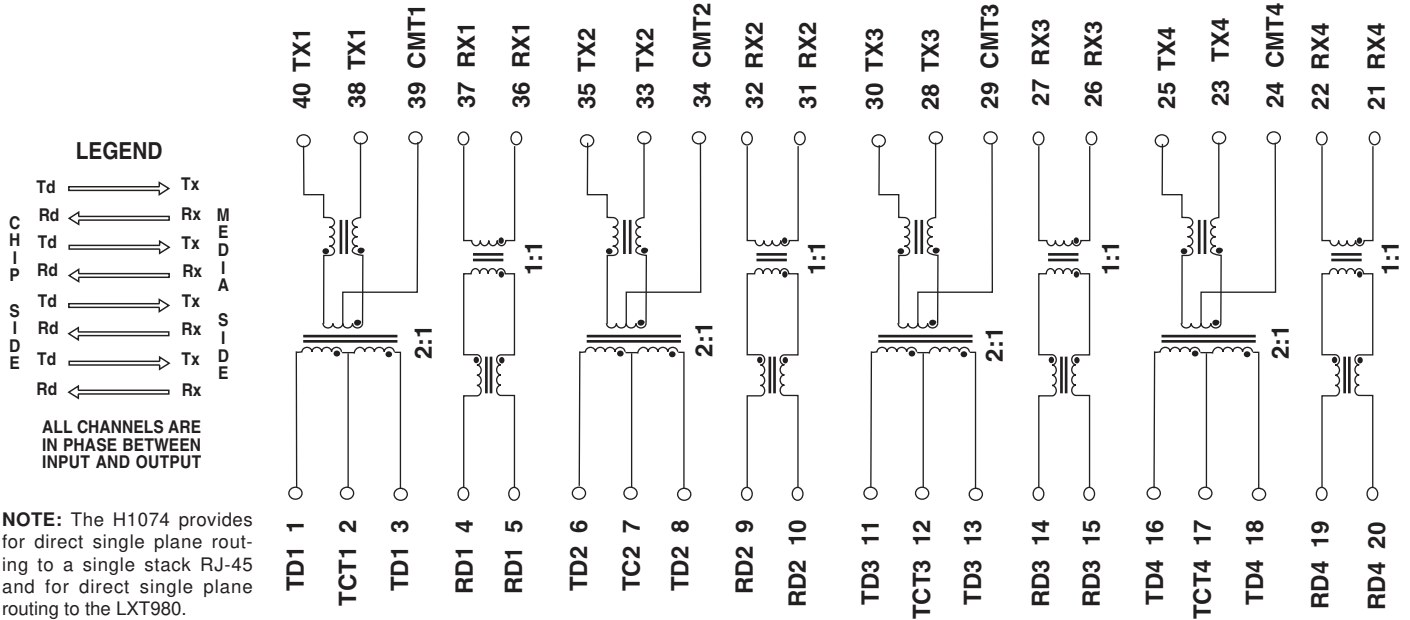

10/100BASE-TX QUAD PORT TRANSFORMER MODULES

For Use with Level One's LXT974, LXT975 and LXT980 Series of PHY Solutions



Tape and Reel Specifications

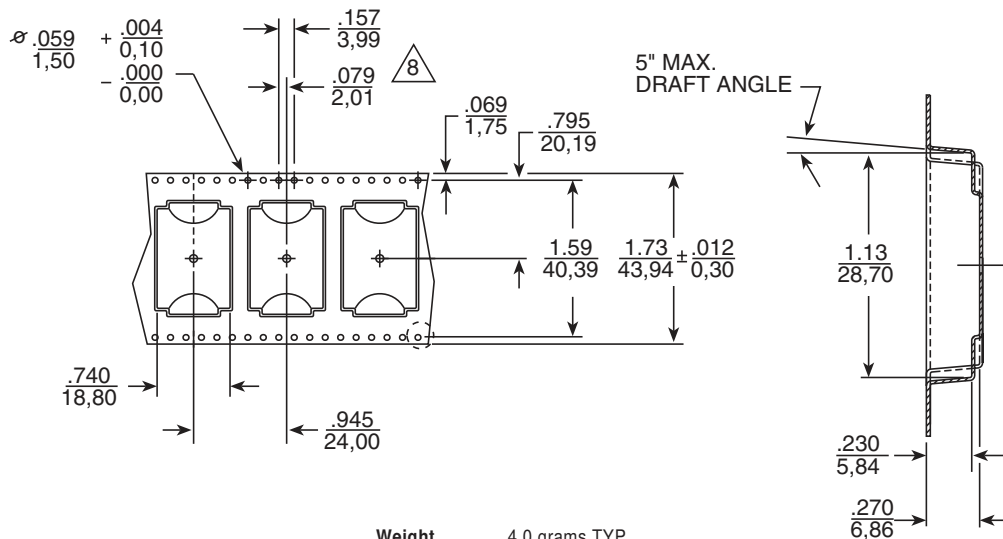

Weight 4.0 grams TYP
 Tube 15/tube
 Tape & Reel 250/reel

For More Information:

Pulse Worldwide Headquarters	Pulse Europe	Pulse China Headquarters	Pulse North China	Pulse South Asia	Pulse North Asia
12220 World Trade Dr. San Diego, CA 92128 U.S.A.	Einsteinstrasse 1 D-71083 Herrenberg Germany	B402, Shenzhen Academy of Aerospace Technology Bldg. 10th Kejinan Rd. High-Tech Zone Nanshan District Shenzhen, PR China 518057	Room 1503 XinYin Building No. 888 YiShan Rd. Shanghai 200233 China	135 Joo Seng Rd. #03-02 PM Industrial Bldg. Singapore 368363	No. 26, Kao Ching Rd. Yang Mei Chen Taoyuan Hsien Taiwan R. O. C.
www.pulseeng.com Tel: 858 674 8100 Fax: 858 674 8262	Tel: 49 7032 7806 0 Fax: 49 7032 7806 135	TEL: 86 755 33966678 FAX: 86 755 33966700	Tel: 86 21 54643211/2 Fax: 86 21 54643210	TEL: 65 6287 8998 FAX: 65 6280 0080	Tel: 886 3 4643715 Fax: 886 3 4641911

Performance warranty of products offered on this data sheet is limited to the parameters specified. Data is subject to change without notice. Other brand and product names mentioned herein may be trademarks or registered trademarks of their respective owners.

© Copyright, 2009, Pulse Engineering, Inc. All rights reserved.