

MATERIAL

Glass-fibre reinforced polyamide based (PA) technopolymer, black colour, matte finish.

STANDARD EXECUTIONS

Black-oxide steel boss, H7 reamed hole, fitting to shaft by means of a supplied grub screw with hexagon socket and cup end UNI 5929-85.

- **VC.792-GXX**: for gravity indicators.
- **VC.792-PXX**: for positive drive indicators.

Rear flange with internal crown gear wheel in acetal resin based (POM) technopolymer. Black-oxide steel screw and anchor pin.

FEATURES AND APPLICATIONS

The ergonomic design enables an effective grip. The lobed shape with no cavities prevents unhealthy residues from depositing and guarantees perfect cleaning.

Particularly suitable for applications on machines and equipment whose parts must be frequently cleaned by using water jets or steam.

INDICATOR CHOICE (TO BE ORDERED SEPARATELY)

To choose the indicator see the table below for possible assembly with indicators.

See also "Assembly instructions" for gravity indicators type G (on page 724) or positive drive indicators type P (on page 726).

ACCESSORIES ON REQUEST

Cover CP-XX (see page 753) for use without the indicator.

SPECIAL EXECUTIONS ON REQUEST

Knob with stainless steel boss.



ELESA Original design

- 1
- 2
- 3
- 4
- 5
- 6
- 7
- 8
- 9
- 10
- 11
- 12
- 13
- 14
- 15
- 16
- 17
- 18

VC.792-GXX

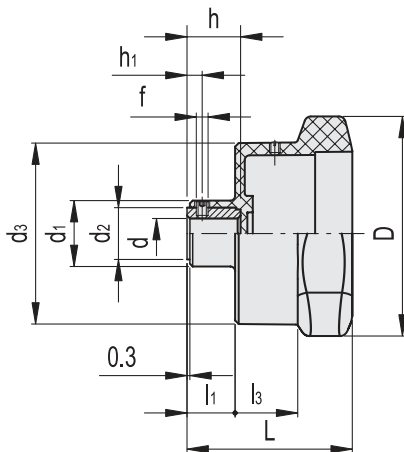

VC.792-PXX

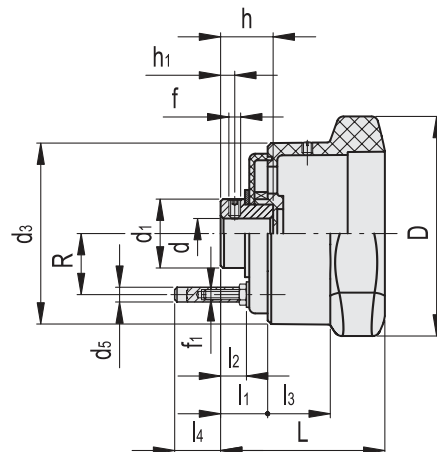

Conversion Table	
1 mm = 0.039 inch	
D	
mm	inch
72	2.83
98	3.86

VC.792-GXX

METRIC

Code	Description	D	L	dH7	h	d1	d2	d3	f	h1	l1	l3	Handwheel/indicator combinations	
CE.30071	VC.792/72-GXX1 A-10	72	52	10	17	24	18	56	M5	6	15.9	19	79	GA01 - GA11
CE.30081	VC.792/98-GXX2 A-12	98	58	12	22	27.5	22	76.5	M5	6	20.5	19	147	GA02 - GA12 - GW12

VC.792-PXX

Code	Description	D	L	dH7	h	d1	d3	d5	f	f1	h1	l1	l2	l3	l4	R	Handwheel/indicator combinations	
CE.30073	VC.792/72-PXX1 A-10	72	55	10	20.5	18	56	6	M5	M4	5	18.5	10.5	19	14.5	19	85	PA01 - PA11
CE.30083	VC.792/98-PXX2 A-12	98	58	12	22	30	76.5	6	M5	M4	6	20	12	19	13.1	28.5	207	PA02 - PA12 - PW12

Position indicators