

THIS DRAWING IS UNPUBLISHED. RELEASED FOR PUBLICATION
 © COPYRIGHT BY TYCO ELECTRONICS CORPORATION. ALL RIGHTS RESERVED.

LOC		DIST		REVISIONS			
P	LTR	DESCRIPTION	DATE	DWN	APVD		
		P		ECO-07-017237	24JUL07	MB	NE

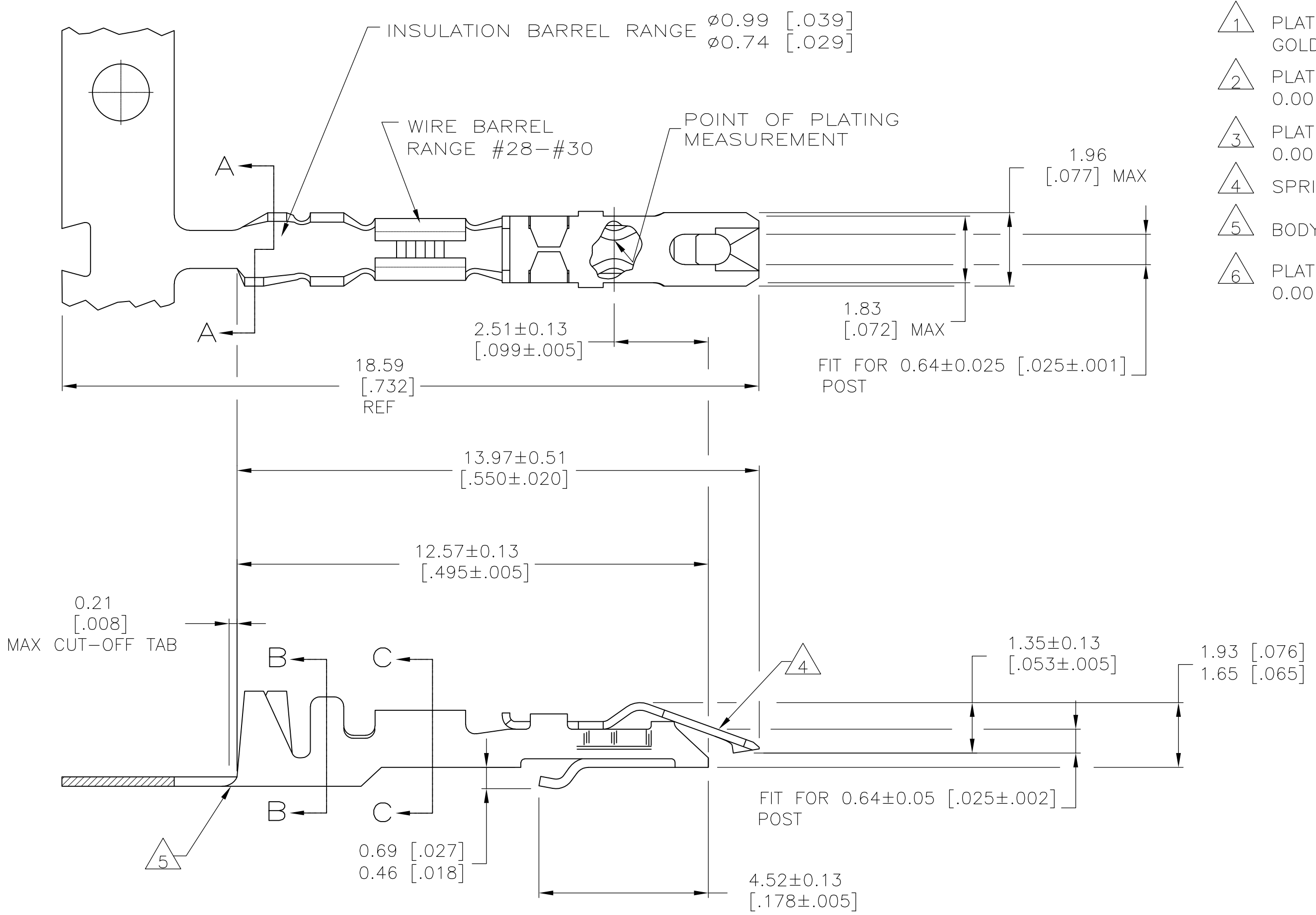

- 1 PLATED WITH 0.00076[.000030] GOLD IN CONTACT AREA, GOLD FLASH ON REMAINDER, OVER 0.00127[.000050] NICKEL.
- 2 PLATED WITH 0.00254[.000100] TIN-LEAD OVER 0.00127[.000050] NICKEL - ENTIRE CONTACT.
- 3 PLATED WITH 0.00127[.000050] GOLD OVER 0.00127[.000050] NICKEL - ENTIRE CONTACT.
- 4 SPRING MATERIAL: STAINLESS STEEL.
- 5 BODY MATERIAL: PHOS BRONZE - FINISH: SEE TABLE.
- 6 PLATED WITH 0.00254 [.000100] TIN OVER 0.00127 [.000050] NICKEL - ENTIRE CONTACT.

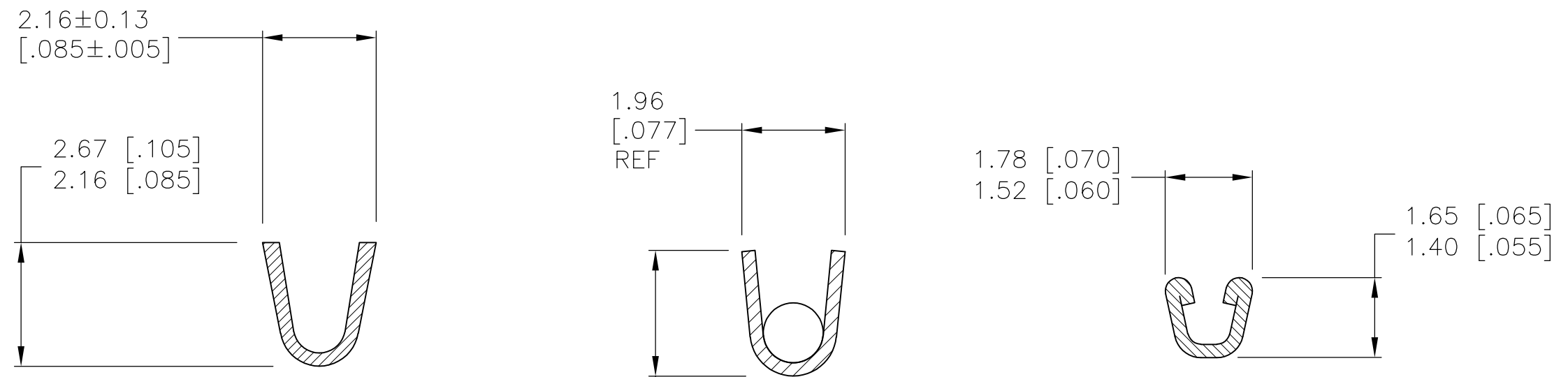

OBSOLETE	6	5-87191-2	5-87190-2
	3	87191-3	87190-3
	2	87191-2	87190-2
	1	87191-1	87190-1
BODY FINISH		PART NO (LOOSE PIECE)	PART NUMBER (STRIP)

THIS DRAWING IS A CONTROLLED DOCUMENT.

DIMENSIONS: mm [INCHES]	TOLERANCES UNLESS OTHERWISE SPECIFIED: 0 PLC ± - 1 PLC ± - 2 PLC ± - 3 PLC ± - 4 PLC ± - ANGLES ± - FINISH	DWN E. BRANDBERG CHK S. SHUEY APVD D. DUPLER PRODUCT SPEC 108-36028 APPLICATION SPEC 114-25006 WEIGHT -	05APR2005 Tyco Electronics Corporation Harrisburg, Pa 17105-3608 NAME CONTACT - LOCKING CLIP FOR 0.64[.025] SQUARE POST SIZE A2 CAGE CODE 00779 DRAWING NO C=87190 RESTRICTED TO -
MATERIAL SEE CALLOUT	FINISH SEE TABLE	CUSTOMER DRAWING	SCALE 10:1 SHEET 1 OF 1 REV P