

PART NUMBER	COUPLING TYPE
DCC-HD19B-310	QUICK CONNECT
DCC-HD19T-310	THREADED

NOTES:

- 1. DCC-HD19T-310 SHOWN IN EXPLODED VIEW. (FIELD INSTALLABLE *HDMI-STYLE CABLE PLUG WITH THREADED COUPLING.)
- 2. THE FIELD INSTALLABLE *HDMI-STYLE CABLE PLUG IS TYPE "A".
- 3. PARTS COME UNASSEMBLED AND INDIVIDUALLY BAGGED.
- 4. SEE SHEET 2 FOR ASSEMBLY INSTRUCTIONS.
- 5. UNLESS OTHERWISE SPECIFIED, DIMENSIONS WITH TWO DECIMAL PLACES HAVE TOLERANCES OF ±0.02

ELECTRICAL:

CONTACT RESISTANCE: 50 MILLIOHMS MAXIMUM
 INSULATION RESISTANCE: 100 MEGAOHMS MINIMUM
 WITHSTANDING VOLTAGE: 500V AC
 CONTACT CURRENT RATING: 0.5 AMPS

PRODUCT RATING:

IP67 & IP68, NEMA 250 (6P), WHEN MATED

OTHER:

OPERATING TEMPERATURE: -20°C TO +80°C [-4°F TO +176°F]
 RECOMMENDED CABLE TYPE: HDMI HIGH SPEED
 RECOMMENDED CABLE O.D. RANGE: Ø0.197 TO Ø0.236 [Ø5.0mm TO Ø6.0mm]

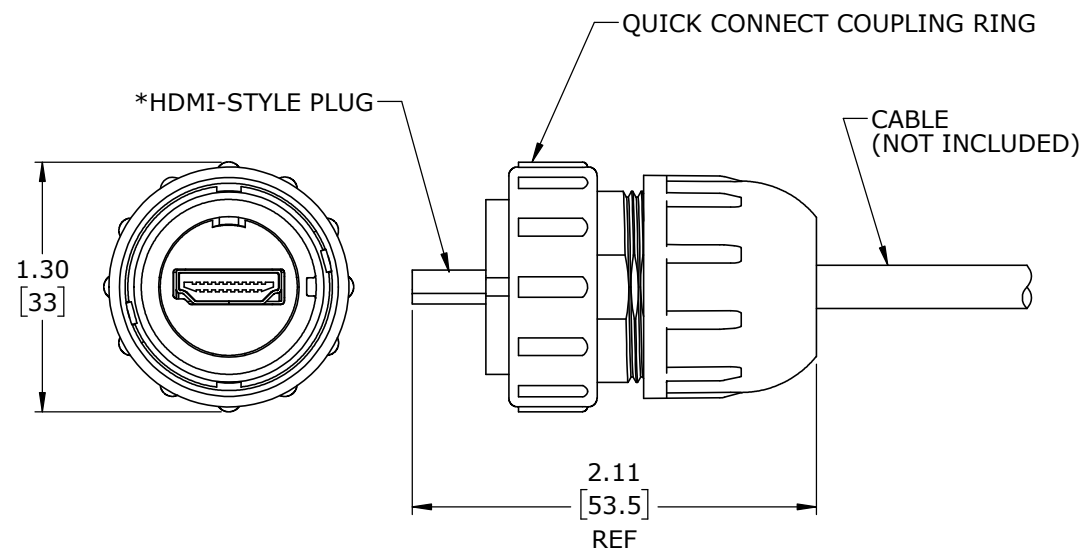
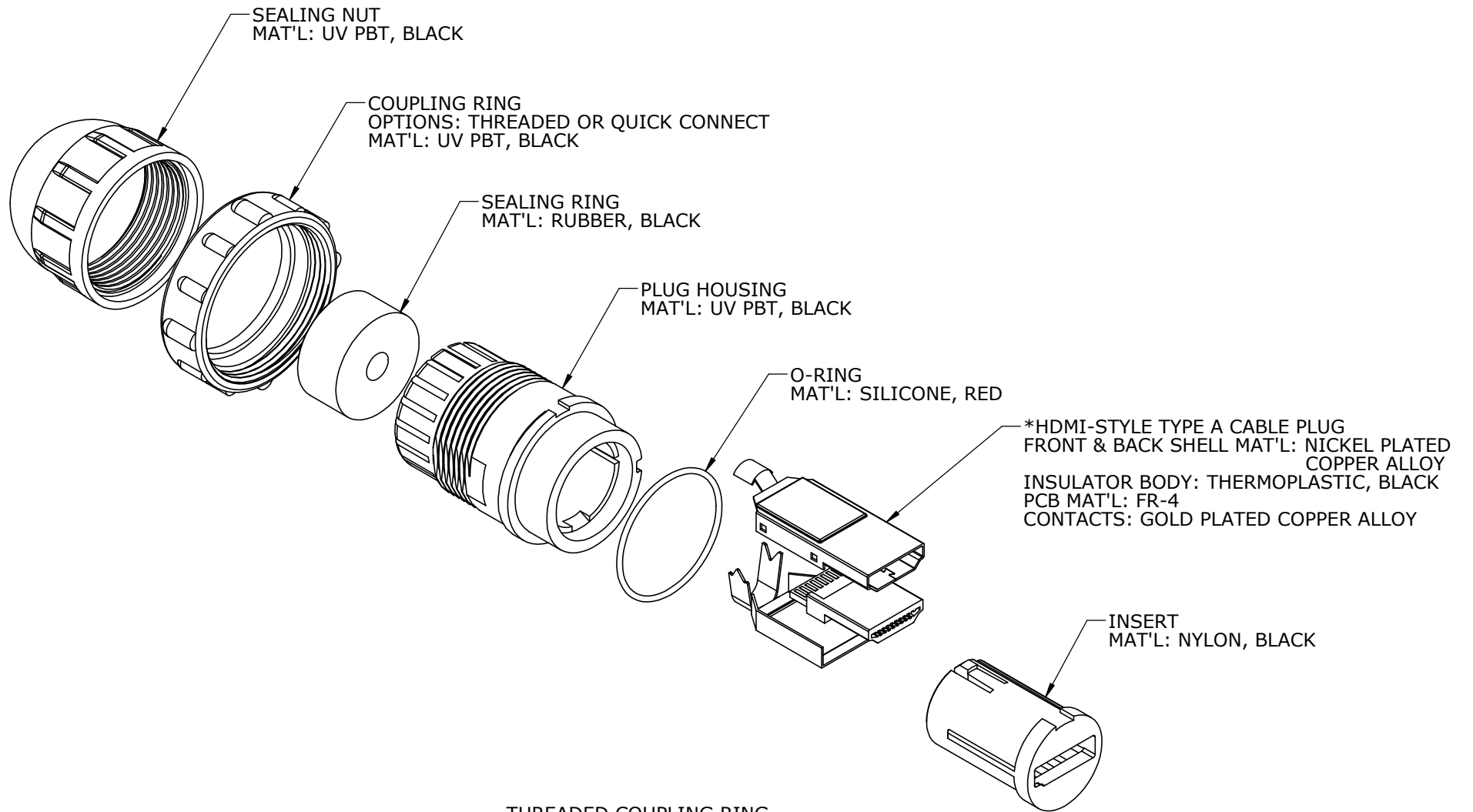

**INDUSTRIAL *HDMI-STYLE CABLE PLUG
 QUICK CONNECT COUPLING
 (B) (DCC-HD19B-310 SHOWN)**

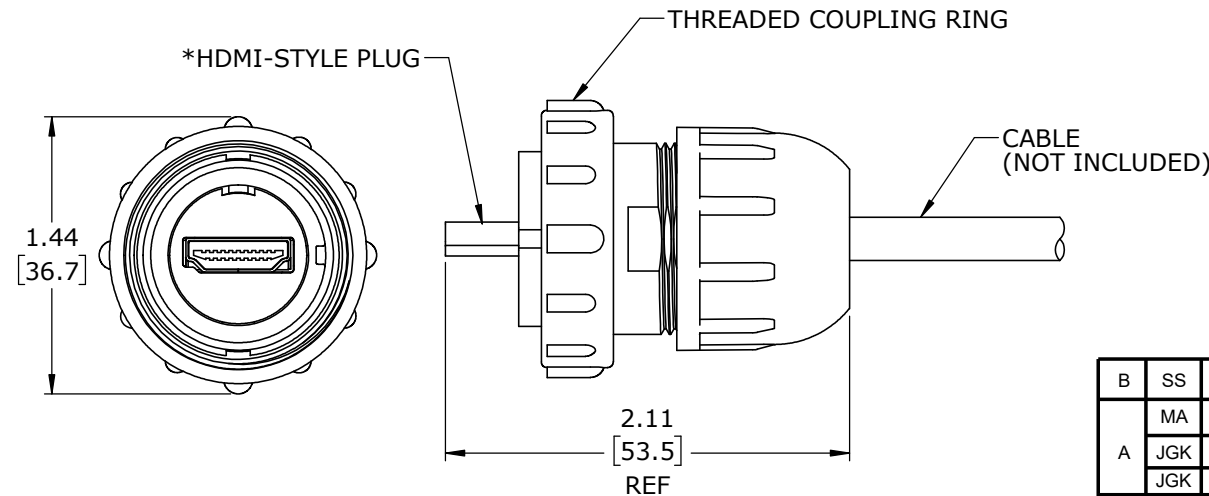

**INDUSTRIAL *HDMI-STYLE CABLE PLUG
 THREADED COUPLING
 (B) (DCC-HD19T-310 SHOWN)**

*HDMI IS A REGISTERED TRADEMARK OF HDMI LICENSING LLC CORPORATION

DIMENSIONS IN BRACKETS [] ARE METRIC.

RoHS COMPLIANT

B	SS	07-26-21	DRAWING NUMBER WAS DCC-HDMI SERIES PER ECR 9593
	MA	01-29-18	DRAWING RELEASED PER PDR 12003
A	JGK	10/13/15	UPDATED MODEL.
	JGK	5/22/13	DRAWING CREATED PER PROJECT #12003.
REV.	INIT.	DATE	DESCRIPTION
	JGK	5/22/13	ORIG. DRAWN BY: DATE: 5/22/13
ALL INFORMATION ILLUSTRATED IS THE PROPERTY OF CONXALL CORPORATION. UNAUTHORIZED DUPLICATION OR DISTRIBUTION OF THIS DOCUMENT IS PROHIBITED.			<p>601 E. WILDWOOD VILLA PARK, IL 60181</p>
ALL UNITS ARE IN FEET, INCHES, FRACTION OF INCHES AND DECIMALS. UNLESS OTHERWISE SPECIFIED TOLERANCES: 3 PLACE DECIMALS ±.005 ANGLES ±1° FRACTIONS ±1/16 - CRITICAL CHARACTERISTIC FLAG PER SPEC. XXXX			
APPROVED BY:		TITLE: INDUSTRIAL *HDMI-STYLE PLUG FIELD INSTALLABLE DATA-CON-X	
SCALE	SIZE	SHEET	CUSTOMER: STANDARD PRODUCT
NTS	B	1 OF 3	
FILE:	DIRECTORY:	PART NUMBER:	REV
DCC-HD19 SERIES	SLW	DCC-HD19 SERIES	B

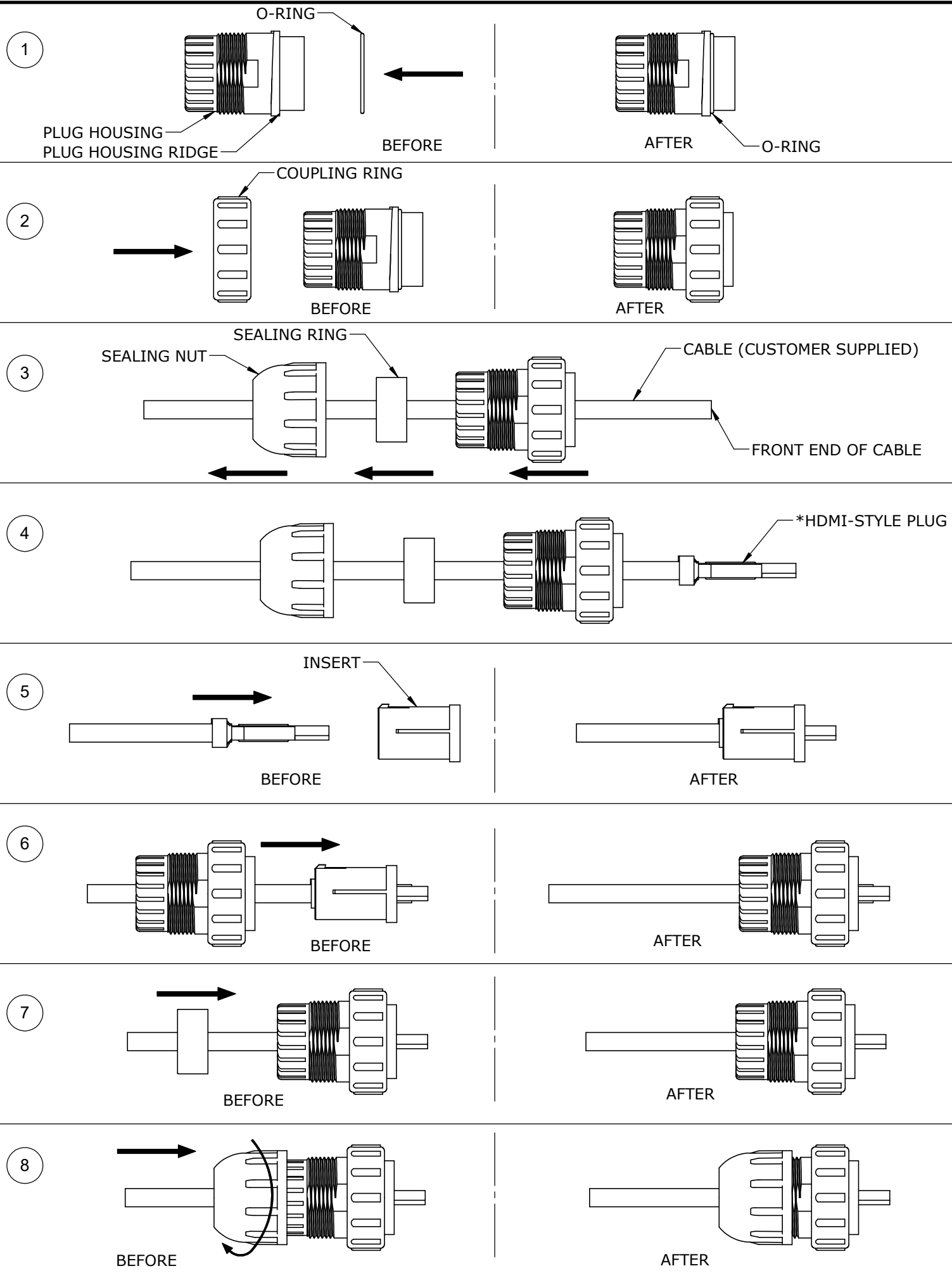

ASSEMBLY INSTRUCTIONS:

1. SLIDE THE O-RING ONTO THE FRONT END OF THE PLUG HOUSING UNTIL IT SEATS UP AGAINST THE RIDGE OF THE PLUG HOUSING.
2. SLIDE THE COUPLING RING OVER THE PLUG HOUSING.
NOTE: MAKE SURE THE FRONT OF THE COUPLING RING CAN SLIDE PAST THE RIDGE ON THE PLUG HOUSING. IF NOT, IT IS INSERTED THE WRONG WAY.
3. SLIDE THE SEALING NUT, SEALING RING, AND PLUG HOUSING/COUPLING RING OVER THE FRONT END OF THE CABLE IN THE FOLLOWING ORDER:
1ST. SEALING NUT.
2ND. SEALING RING.
3RD. PLUG HOUSING/COUPLING RING.
4. TERMINATE THE *HDMI-STYLE PLUG TO THE CABLE.
NOTE: SEE FIGURE 1 FOR *HDMI-STYLE PLUG ASSEMBLY INSTRUCTIONS.
SEE FIGURE 3 FOR RECOMMENDED STRIPPING DETAIL.
5. SLIDE THE *HDMI-STYLE PLUG INTO THE BACK END OF THE INSERT UNTIL IT SNAPS INTO PLACE.
NOTE: SEE FIGURE 2 FOR INSERT AND PLUG ALIGNMENT GUIDE.
6. SLIDE THE INSERT/*HDMI-STYLE PLUG INTO THE FRONT END OF THE PLUG HOUSING UNTIL IT SNAPS INTO PLACE.
7. PUSH THE SEALING RING INTO THE REAR OF THE PLUG HOUSING.
NOTE: NO PART OF THE SEALING RING SHOULD EXTEND PAST THE REAR OF THE PLUG HOUSING.
8. SCREW THE SEALING NUT ONTO THE PLUG HOUSING. THE RECOMMENDED TIGHTENING TORQUE IS 10-12 IN-LBS FORCE.
NOTE: MAKE SURE THAT THE SEALING RING SQUEEZES TIGHTLY AROUND THE CABLE O.D.

*HDMI IS A REGISTERED TRADEMARK OF HDMI LICENSING LLC CORPORATION

RoHS COMPLIANT

B	SS	07-26-21	DRAWING NUMBER WAS DCC-HDMI SERIES PER ECR 9593
A	MA	01-29-18	DRAWING RELEASED PER PDR 12003
	JGK	10/13/15	UPDATED MODEL.
	JGK	5/22/13	DRAWING CREATED PER PROJECT #12003.
REV.	INIT.	DATE	DESCRIPTION
	JGK	5/22/13	ORIG. DRAWN BY: DATE: 5/22/13
ALL INFORMATION ILLUSTRATED IS THE PROPERTY OF CONXALL CORPORATION. UNAUTHORIZED DUPLICATION OR DISTRIBUTION OF THIS DOCUMENT IS PROHIBITED.			<p>601 E. WILDWOOD VILLA PARK, IL 60181</p>
<small>ALL UNITS ARE IN FEET, INCHES, FRACTION OF INCHES AND DECIMALS. UNLESS OTHERWISE SPECIFIED TOLERANCES: 3 PLACE DECIMALS ±.005 ANGLES ±1° FRACTIONS ±1/16 - CRITICAL CHARACTERISTIC FLAG PER SPEC. XXXX</small>			
APPROVED BY:		TITLE: INDUSTRIAL *HDMI-STYLE PLUG FIELD INSTALLABLE	
SCALE	SIZE	SHEET	CUSTOMER: STANDARD PRODUCT
NTS	B	2 OF 3	
FILE: DCC-HD19 SERIES	DIRECTORY: SLW	PART NUMBER: DCC-HD19 SERIES	REV B

FIGURE 1

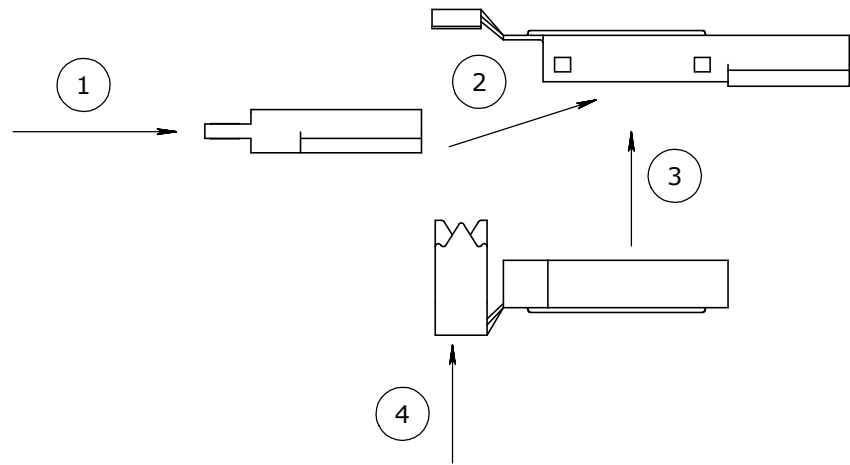

***HDMI-STYLE PLUG ASSEMBLY INSTRUCTIONS**

1. SOLDER THE CABLE WIRES TO THE PCB BODY. SEE FIGURE 3 FOR RECOMMENDED CABLE STRIPPING DETAILS.
2. PLACE THE PCB BODY INTO THE FRONT SHELL AND PUSH FORWARD UNTIL IT SITS FIRMLY INTO THE FRONT SHELL.
3. SNAP THE BACK SHELL ONTO THE FRONT SHELL.
4. CRIMP THE BACK SHELL CLAMP AROUND THE CABLE JACKET.

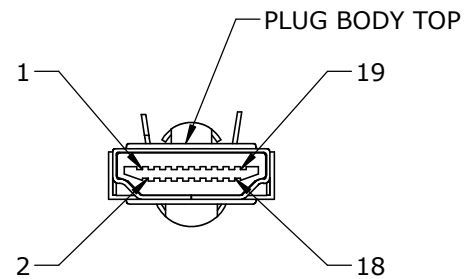

FIGURE 2

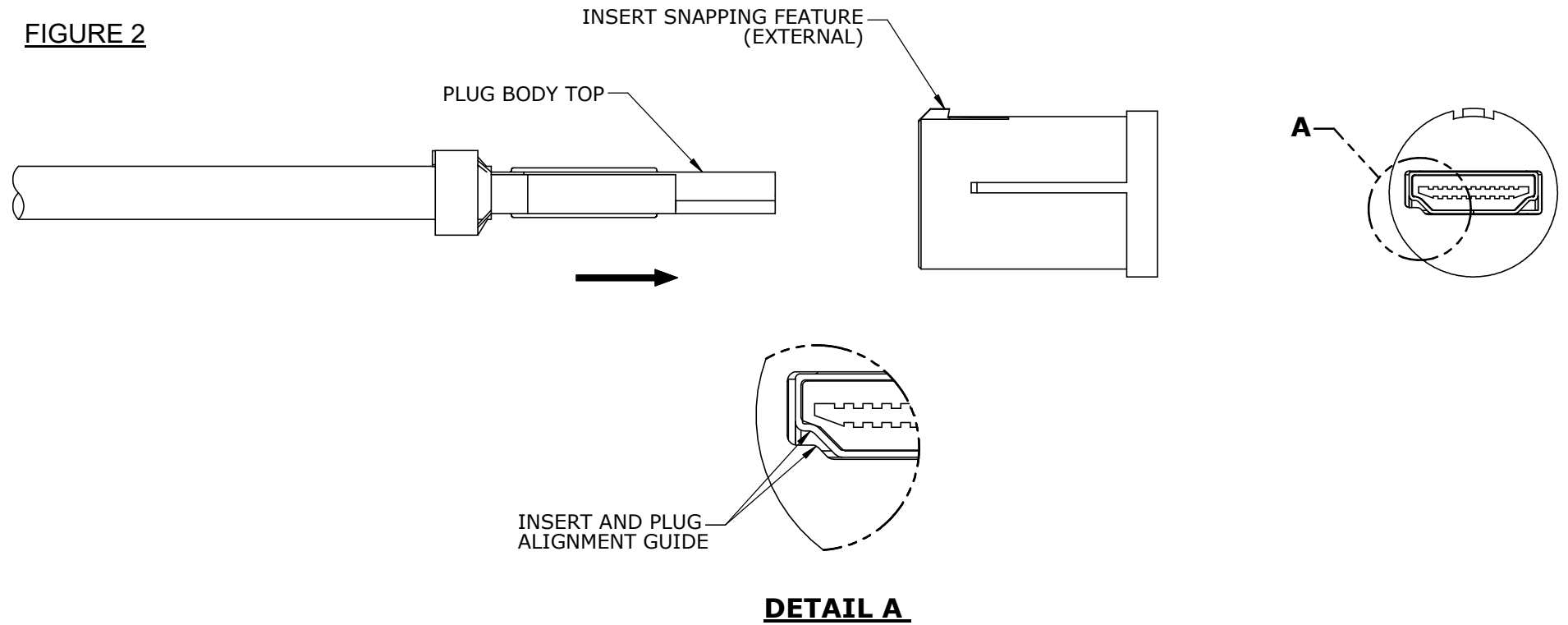
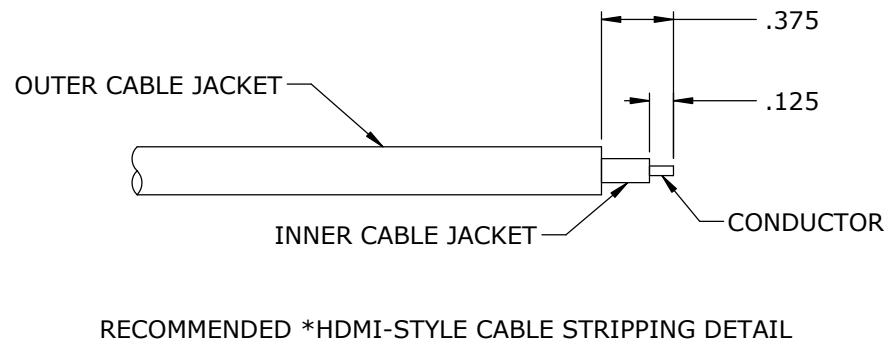



FIGURE 3



*HDMI IS A REGISTERED TRADEMARK OF HDMI LICENSING LLC CORPORATION

RoHS COMPLIANT

B	SS	07-26-21	DRAWING NUMBER WAS DCC-HDMI SERIES PER ECR 9593
	MA	01-29-18	DRAWING RELEASED PER PDR 12003
A	JGK	10/13/15	UPDATED MODEL.
	JGK	5/22/13	DRAWING CREATED PER PROJECT #12003.
REV.	INIT.	DATE	DESCRIPTION
	JGK	5/22/13	ORIG. DRAWN BY: DATE: JGK 5/22/13
ALL INFORMATION ILLUSTRATED IS THE PROPERTY OF CONXALL CORPORATION. UNAUTHORIZED DUPLICATION OR DISTRIBUTION OF THIS DOCUMENT IS PROHIBITED.			 601 E. WILDWOOD VILLA PARK, IL 60181
ALL UNITS ARE IN FEET, INCHES, FRACTION OF INCHES AND DECIMALS. UNLESS OTHERWISE SPECIFIED TOLERANCES: 3 PLACE DECIMALS ±.005 ANGLES ±1° FRACTIONS ±1/16 - CRITICAL CHARACTERISTIC FLAG PER SPEC. XXXX			
APPROVED BY:		SCALE: NTS	TITLE: INDUSTRIAL *HDMI-STYLE PLUG FIELD INSTALLABLE DATA-CON-X
FILE: DCC-HD19 SERIES		SIZE: B	CUSTOMER: STANDARD PRODUCT
DIRECTORY: SLW		SHEET: 3 OF 3	PART NUMBER: DCC-HD19 SERIES
			REV: B