

Mechanical Dimensions: Inches [mm]

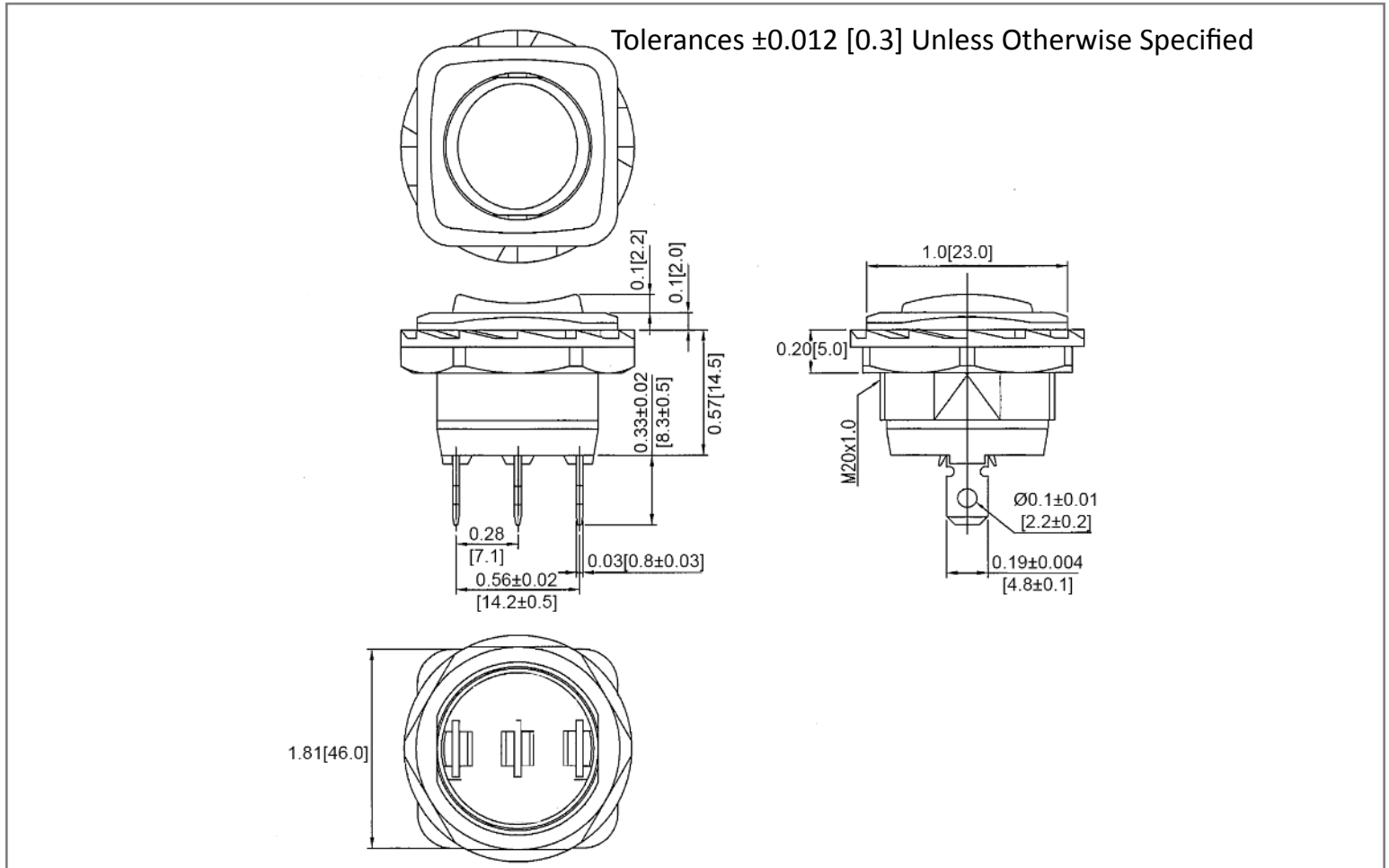

Mounting Hole

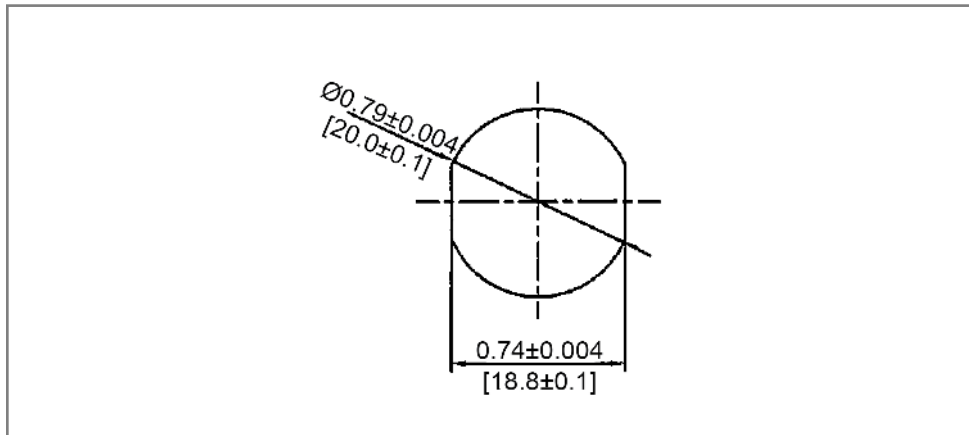

Circuit Diagram

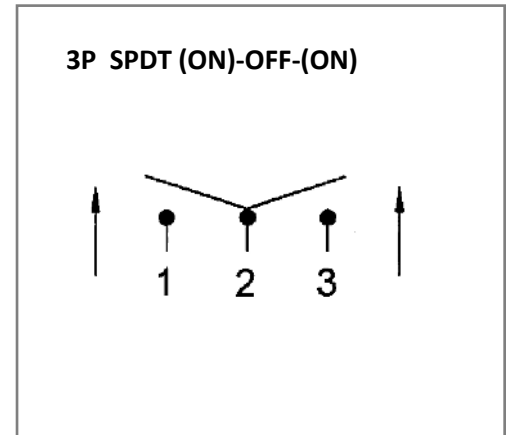

Electrical Specifications

Rating	16A 125V AC, 10A 250V AC 16(4)A 125/250V AC
Contact Resistance	50m ohm Max
Insulation Resistance	DC 500V 100M ohm Min
Dielectric Strength	AC 1500V 1 minute

Material Specifications

Frame	Nylon #66 + 33%GF, Black
Actuator	Nylon #66, Black
Printed	None

Rev	Date of issue	Revision Notes	Designed	Approved
A	12-03-2021	Initial Drawing	RC	OF