



www.ti.com

*SpeedPLUS™* Dual, Wideband, Single-Supply  
**OPERATIONAL AMPLIFIER**

**FEATURES**

- HIGH BANDWIDTH: 150MHz (G = +2)
- +3V TO +10V OPERATION
- INPUT RANGE INCLUDES GROUND
- 4.8V OUTPUT SWING ON +5V SUPPLY
- HIGH OUTPUT CURRENT: 80mA
- HIGH SLEW RATE: 250V/μs
- LOW INPUT VOLTAGE NOISE: 5.6nV/√HZ

**APPLICATIONS**

- DIFFERENTIAL RECEIVERS/DRIVERS
- ACTIVE FILTERS
- MATCHED I AND Q CHANNEL AMPLIFIERS
- CCD IMAGING CHANNELS
- LOW-POWER ULTRASOUND

**DESCRIPTION**

The OPA2634 is a dual, low-power, voltage-feedback, high-speed operational amplifier designed to operate on +3V or +5V single-supply voltage. Operation on ±5V or +10V supplies is also supported. The input range extends below ground and to within 1.2V of the positive supply. Using complementary common-emitter outputs provides an output swing to within 30mV of ground and 140mV of positive supply.

Low distortion operation is ensured by the high gain bandwidth product (140MHz) and slew rate (250V/μs). This makes the OPA2634 an ideal differential input buffer stage to 3V and 5V CMOS converters. Unlike other low-power, single-supply operational amplifiers, distortion performance improves as the signal swing is decreased. A low 5.6nV/√Hz input voltage noise supports wide dynamic-range operation.

The OPA2634 is available in an industry-standard dual pinout SO-8 package. Where a single-channel, single-supply operational amplifier is required, consider the OPA634 and OPA635. Where lower supply current and speed are required, consider the OPA2631.

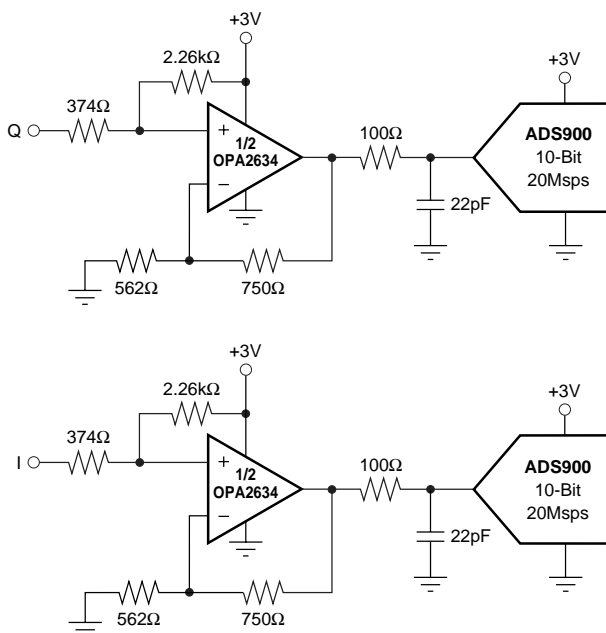

**RELATED PRODUCTS**

DESCRIPTION	SINGLES	DUALS
Medium Speed, No Disable With Disable	OPA631 OPA632	OPA2631 —
High Speed, No Disable With Disable	OPA634 OPA635	OPA2634 —



# SPECIFICATIONS: $V_S = +5V$

At  $T_A = 25^\circ C$ ,  $G = +2$ ,  $R_F = 750\Omega$ , and  $R_L = 150\Omega$  to  $V_S/2$ , unless otherwise noted (see Figure 1).

PARAMETER	CONDITIONS	OPA2634U				UNITS	MIN/ MAX	TEST LEVEL <sup>(1)</sup>
		TYP	GUARANTEED					
		+25°C	+25°C	0°C to 70°C	-40°C to +85°C			
<b>AC PERFORMANCE (Figure 1)</b>								
Small-Signal Bandwidth	$G = +2, V_O \leq 0.5V_{p-p}$	150	100	84	78	MHz	min	B
	$G = +5, V_O \leq 0.5V_{p-p}$	36	24	20	18	MHz	min	B
	$G = +10, V_O \leq 0.5V_{p-p}$	16	11	10	8	MHz	min	B
Gain Bandwidth Product	$G \geq +10$	140	100	82	75	MHz	min	B
Peaking at a Gain of +1	$V_O \leq 0.5V_{p-p}$	5	—	—	—	dB	typ	C
Slew Rate	$G = +2, 2V$ Step	250	170	125	115	V/ $\mu s$	min	B
Rise Time	0.5V Step	2.4	3.4	4.7	5.2	ns	max	B
Fall Time	0.5V Step	2.4	3.5	4.5	4.8	ns	max	B
Settling Time to 0.1%	$G = +2, 1V$ Step	15	19	22	23	ns	max	B
Spurious Free Dynamic Range	$V_O = 2V_{p-p}, f = 5MHz$	63	56	51	50	dB	min	B
Input Voltage Noise	$f > 1MHz$	5.6	6.2	7.3	7.7	nV/ $\sqrt{Hz}$	max	B
Input Current Noise	$f > 1MHz$	2.8	3.8	4.2	5	pA/ $\sqrt{Hz}$	max	B
NTSC Differential Gain		0.10	—	—	—	%	typ	C
NTSC Differential Phase		0.16	—	—	—	degrees	typ	C
Channel-to-Channel Crosstalk	Input Referred, 5MHz	< -90	—	—	—	dB	typ	C
<b>DC PERFORMANCE</b>								
Open-Loop Voltage Gain	$R_L = 150\Omega$	66	<b>63</b>	60	53	dB	min	A
Input Offset Voltage		$\pm 3$	$\pm 7$	$\pm 8$	$\pm 10$	mV	max	A
Average Offset Voltage Drift		—	—	—	4.6	$\mu V/^\circ C$	max	B
Input Bias Current	$V_{CM} = 2.0V$	25	<b>47</b>	57	84	$\mu A$	max	A
Input Offset Current	$V_{CM} = 2.0V$	$\pm 0.6$	<b><math>\pm 2.25</math></b>	$\pm 2.6$	$\pm 4.5$	$\mu A$	max	A
Input Offset Current Drift		—	—	—	15	nA/ $^\circ C$	max	B
<b>INPUT</b>								
Least Positive Input Voltage		-0.24	-0.1	-0.05	-0.01	V	max	B
Most Positive Input Voltage		3.8	<b>3.5</b>	3.45	3.4	V	min	A
Common-Mode Rejection Ratio (CMRR)	Input Referred	78	<b>73</b>	71	63	dB	min	A
Input Impedance								
Differential-Mode		10    2.1	—	—	—	k $\Omega$    pF	typ	C
Common-Mode		400    1.2	—	—	—	k $\Omega$    pF	typ	C
<b>OUTPUT</b>								
Least Positive Output Voltage	$R_L = 1k\Omega$ to 2.5V	0.03	<b>0.09</b>	0.10	0.11	V	max	A
	$R_L = 150\Omega$ to 2.5V	0.1	<b>0.16</b>	0.17	0.24	V	max	A
Most Positive Output Voltage	$R_L = 1k\Omega$ to 2.5V	4.86	<b>4.8</b>	4.75	4.7	V	min	A
	$R_L = 150\Omega$ to 2.5V	4.65	<b>4.55</b>	4.5	4.4	V	min	A
Current Output, Sourcing		80	<b>50</b>	45	20	mA	min	A
Current Output, Sinking		100	<b>73</b>	59	18	mA	min	A
Short-Circuit Current (output shorted to either supply)		100	—	—	—	mA	typ	C
Closed-Loop Output Impedance	$G = +2, f \leq 100kHz$	0.2	—	—	—	$\Omega$	typ	C
<b>POWER SUPPLY</b>								
Minimum Operating Voltage		—	2.7	2.7	2.7	V	min	B
Maximum Operating Voltage		—	<b>10.5</b>	10.5	10.5	V	max	A
Maximum Quiescent Current	$V_S = +5V$ , Each Channel	12	<b>12.7</b>	13.2	13.5	mA	max	A
Minimum Quiescent Current	$V_S = +5V$ , Each Channel	12	<b>11.3</b>	9.75	8.5	mA	min	A
Power Supply Rejection Ratio (PSRR)	Input Referred	55	<b>52</b>	50	49	dB	min	A
<b>THERMAL CHARACTERISTICS</b>								
Specification: U		-40 to +85	—	—	—	$^\circ C$	typ	C
Thermal Resistance								
U SO-8		125	—	—	—	$^\circ C/W$	typ	C

NOTE: (1) Test Levels: (A) 100% tested at 25°C. Over temperature limits by characterization and simulation. (B) Limits set by characterization and simulation. (C) Typical value only for information.

# SPECIFICATIONS: $V_S = +3V$

At  $T_A = 25^\circ\text{C}$ ,  $G = +2$  and  $R_L = 150\Omega$  to  $V_S/2$ , unless otherwise noted (see Figure 2).

PARAMETER	CONDITIONS	OPA2634U				UNITS	MIN/ MAX	TEST LEVEL <sup>(1)</sup>
		TYP	GUARANTEED					
		+25°C	+25°C	0°C to 70°C	-40°C to +85°C			
<b>AC PERFORMANCE (Figure 2)</b>								
Small-Signal Bandwidth	$G = +2, V_O \leq 0.5V_{p-p}$	110	77	65	58	MHz	min	B
	$G = +5, V_O \leq 0.5V_{p-p}$	39	24	20	19	MHz	min	B
	$G = +10, V_O \leq 0.5V_{p-p}$	16	12	10	8	MHz	min	B
Gain Bandwidth Product	$G \geq +10$	150	100	85	80	MHz	min	B
Peaking at a Gain of +1	$V_O \leq 0.5V_{p-p}$	5	—	—	—	dB	typ	C
Slew Rate	1V Step	215	160	123	82	V/ $\mu\text{s}$	min	B
Rise Time	0.5V Step	2.8	4.3	4.5	6.3	ns	max	B
Fall Time	0.5V Step	3.0	4.4	4.6	6.0	ns	max	B
Settling Time to 0.1%	1V Step	14	30	32	38	ns	max	B
Spurious Free Dynamic Range	$V_O = 1V_{p-p}, f = 5\text{MHz}$	65	56	52	47	dB	min	B
Input Voltage Noise	$f > 1\text{MHz}$	5.6	6.2	7.3	7.7	nV/ $\sqrt{\text{Hz}}$	max	B
Input Current Noise	$f > 1\text{MHz}$	2.8	3.7	4.2	4.4	pA/ $\sqrt{\text{Hz}}$	max	B
Channel-to-Channel Crosstalk	Input Referred, 5MHz	< -90	—	—	—	dB	typ	C
<b>DC PERFORMANCE</b>								
Open-Loop Voltage Gain	$R_L = 150\Omega$	65	<b>61</b>	59	55	dB	min	A
Input Offset Voltage		$\pm 1.5$	$\pm 4$	$\pm 5$	$\pm 6$	mV	max	A
Average Offset Voltage Drift		—	—	—	46	$\mu\text{V}/^\circ\text{C}$	max	B
Input Bias Current	$V_{CM} = 1.0V$	25	<b>45</b>	59	64	$\mu\text{A}$	max	A
Input Offset Current	$V_{CM} = 1.0V$	$\pm 0.6$	$\pm 2$	$\pm 2.3$	$\pm 4$	$\mu\text{A}$	max	A
Input Offset Current Drift		—	—	—	40	nA/ $^\circ\text{C}$	max	B
<b>INPUT</b>								
Least Positive Input Voltage		-0.25	-0.1	-0.05	-0.01	V	max	B
Most Positive Input Voltage		1.8	<b>1.6</b>	1.55	1.5	V	min	A
Common-Mode Rejection Ratio (CMRR)	Input Referred	75	<b>65</b>	62	59	dB	min	A
Input Impedance								
Differential-Mode		10    2.1	—	—	—	k $\Omega$    p	typ	C
Common-Mode		400    1.2	—	—	—	k $\Omega$    p	typ	C
<b>OUTPUT</b>								
Least Positive Output Voltage	$R_L = 1k\Omega$ to 1.5V	0.03	<b>0.07</b>	0.08	0.09	V	max	A
	$R_L = 150\Omega$ to 1.5V	0.08	<b>0.16</b>	0.19	0.43	V	max	A
Most Positive Output Voltage	$R_L = 1k\Omega$ to 1.5V	2.9	<b>2.86</b>	2.85	2.45	V	min	A
	$R_L = 150\Omega$ to 1.5V	2.8	<b>2.7</b>	2.67	2.2	V	min	A
Current Output, Sourcing		45	<b>35</b>	30	12	mA	min	A
Current Output, Sinking		65	<b>30</b>	27	10	mA	min	A
Short-Circuit Current (output shorted to either supply)		100	—	—	—	mA	typ	C
Closed-Loop Output Impedance	Figure 2, $f < 100\text{kHz}$	0.2	—	—	—	$\Omega$	typ	C
<b>POWER SUPPLY</b>								
Minimum Operating Voltage		—	2.7	2.7	2.7	V	min	B
Maximum Operating Voltage		—	<b>10.5</b>	10.5	10.5	V	max	A
Maximum Quiescent Current	$V_S = +3V$ , Each Channel	10.8	<b>11.5</b>	11.8	12.0	mA	max	A
Minimum Quiescent Current	$V_S = +3V$ , Each Channel	10.8	<b>10.1</b>	8.6	8.0	mA	min	A
Power Supply Rejection Ratio (PSRR)	Input Referred	50	<b>47</b>	44	43	dB	min	A
<b>THERMAL CHARACTERISTICS</b>								
Specification: U		-40 to +85	—	—	—	$^\circ\text{C}$	typ	C
Thermal Resistance								
U SO-8		125	—	—	—	$^\circ\text{C}/\text{W}$	typ	C

NOTE: (1) Test Levels: (A) 100% tested at 25°C. Over temperature limits by characterization and simulation. (B) Limits set by characterization and simulation. (C) Typical value only for information.

The information provided herein is believed to be reliable; however, BURR-BROWN assumes no responsibility for inaccuracies or omissions. BURR-BROWN assumes no responsibility for the use of this information, and all use of such information shall be entirely at the user's own risk. Prices and specifications are subject to change without notice. No patent rights or licenses to any of the circuits described herein are implied or granted to any third party. BURR-BROWN does not authorize or warrant any BURR-BROWN product for use in life support devices and/or systems.

## ABSOLUTE MAXIMUM RATINGS

Power Supply .....	+11V <sub>DC</sub>
Internal Power Dissipation .....	See Thermal Analysis
Differential Input Voltage .....	±1.2V
Input Voltage Range .....	-0.5 to +V <sub>S</sub> +0.3V
Storage Temperature Range .....	-40°C to +125°C
Lead Temperature (soldering, 10s) .....	+300°C
Junction Temperature (T <sub>J</sub> ) .....	+175°C



## ELECTROSTATIC DISCHARGE SENSITIVITY

Electrostatic discharge can cause damage ranging from performance degradation to complete device failure. Burr-Brown Corporation recommends that all integrated circuits be handled and stored using appropriate ESD protection methods.

ESD damage can range from subtle performance degradation to complete device failure. Precision integrated circuits may be more susceptible to damage because very small parametric changes could cause the device not to meet published specifications.

## PIN CONFIGURATIONS

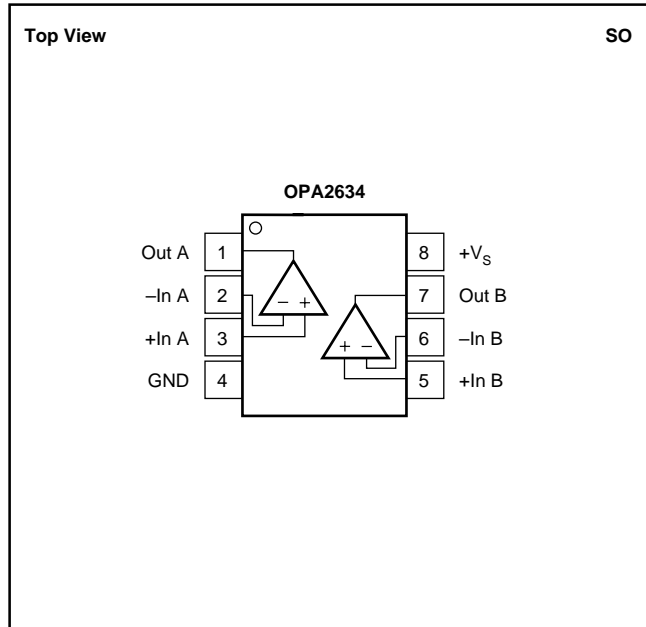

## PACKAGE/ORDERING INFORMATION

PRODUCT	PACKAGE	PACKAGE DRAWING NUMBER	SPECIFIED TEMPERATURE RANGE	PACKAGE MARKING	ORDERING NUMBER <sup>(1)</sup>	TRANSPORT MEDIA
OPA2634U "	SO-8 Surface-Mount "	182 "	-40°C to +85°C "	OPA2634U "	OPA2634U OPA2634U/2K5	Rails Tape and Reel

NOTE: (1) Models with a slash (/) are available only in Tape and Reel in the quantities indicated (e.g., /2K5 indicates 2500 devices per reel). Ordering 2500 pieces of "OPA2634U/2K5" will get a single 2500-piece Tape and Reel.

# TYPICAL PERFORMANCE CURVES: $V_S = +5V$

At  $T_A = 25^\circ C$ ,  $G = +2$ ,  $R_F = 750\Omega$ , and  $R_L = 150\Omega$  to  $V_S/2$ , unless otherwise noted (see Figure 1).

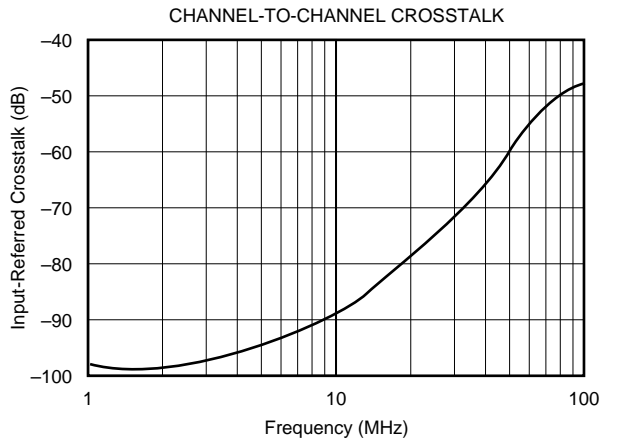
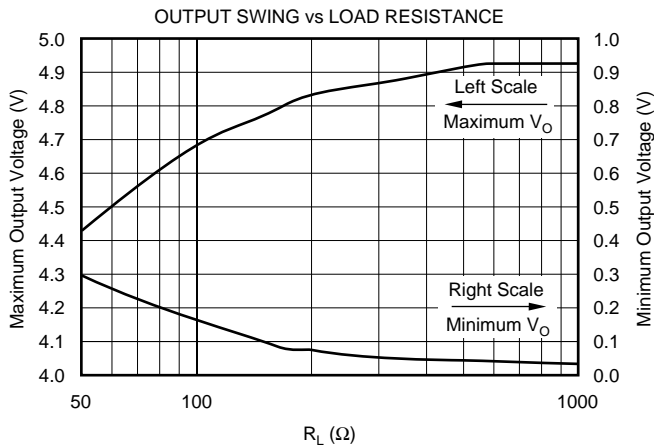
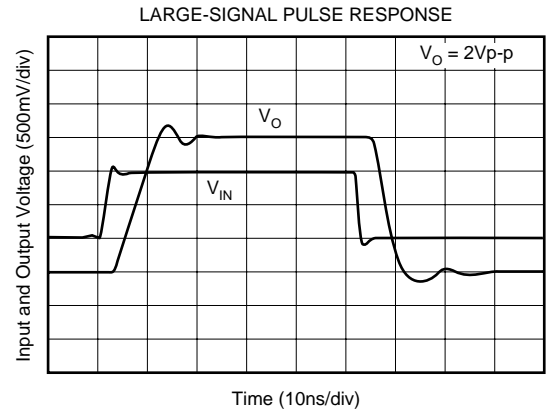
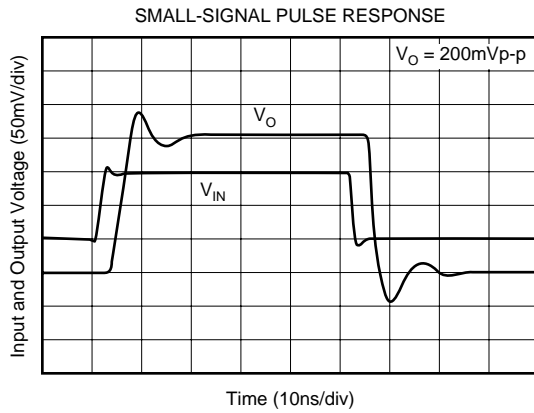
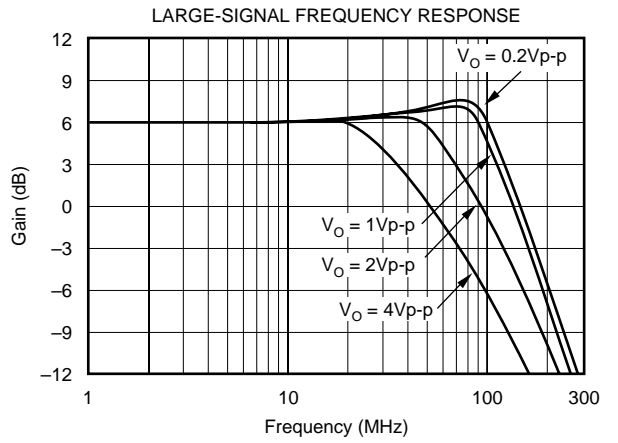
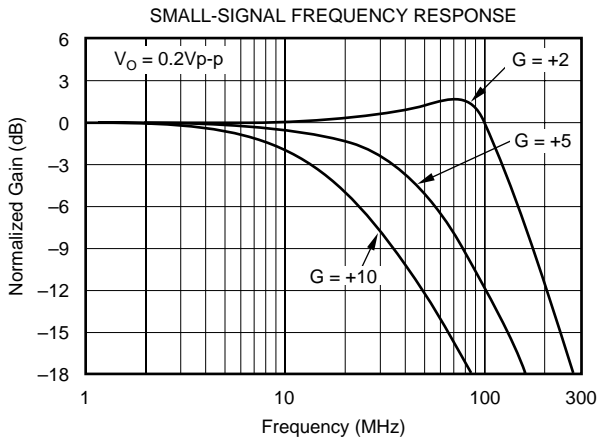

# TYPICAL PERFORMANCE CURVES: $V_S = +5V$ (Cont.)

At  $T_A = 25^\circ C$ ,  $G = +2$ ,  $R_F = 750\Omega$ , and  $R_L = 150\Omega$  to  $V_S/2$ , unless otherwise noted (see Figure 1).

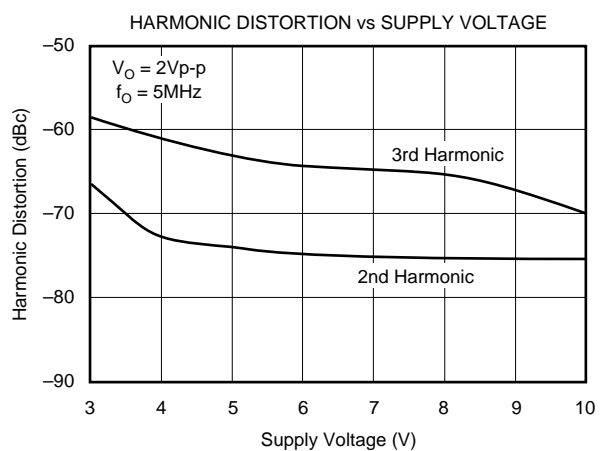
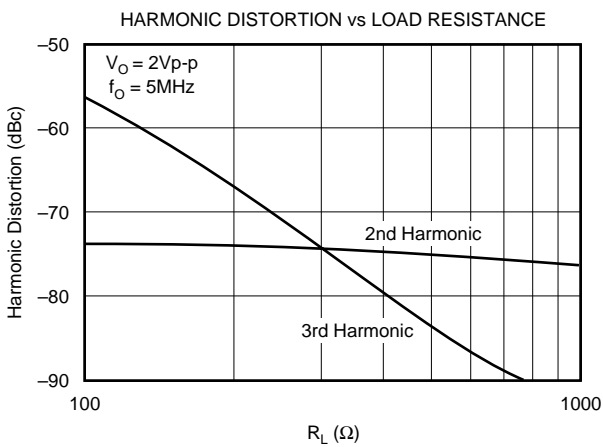
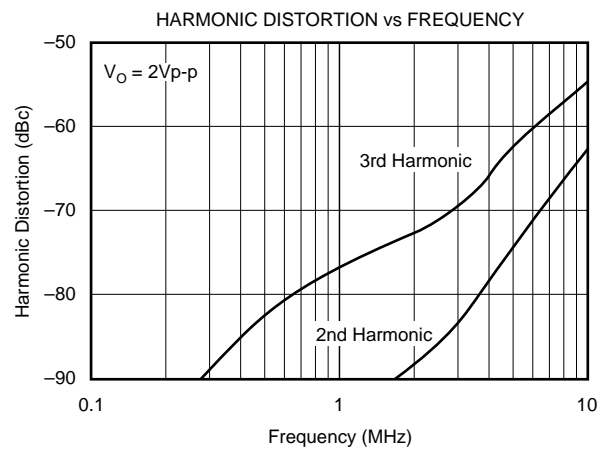
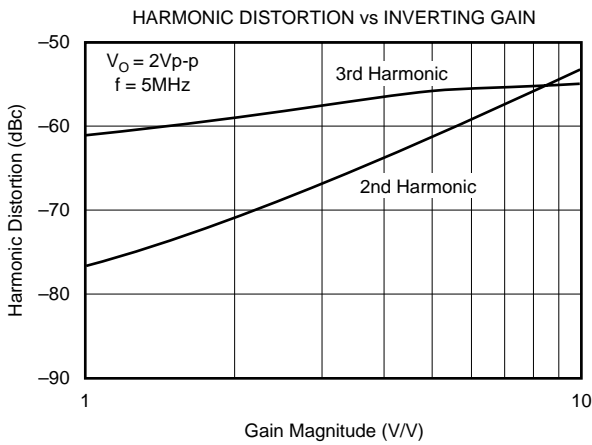
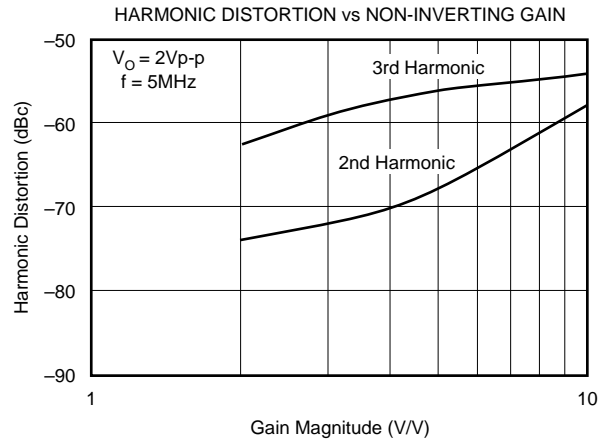
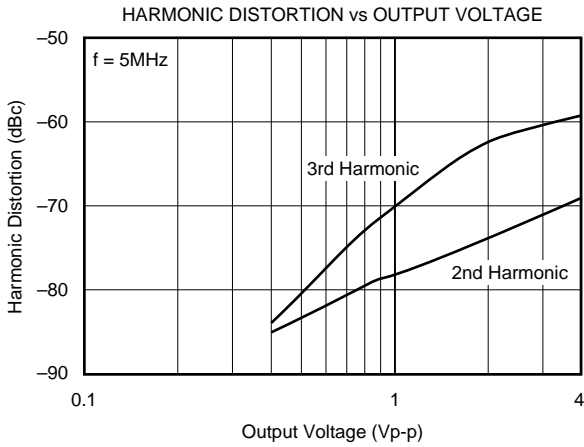

# TYPICAL PERFORMANCE CURVES: $V_S = +5V$ (Cont.)

At  $T_A = 25^\circ C$ ,  $G = +2$ ,  $R_F = 750\Omega$ , and  $R_L = 150\Omega$  to  $V_S/2$ , unless otherwise noted (see Figure 1).

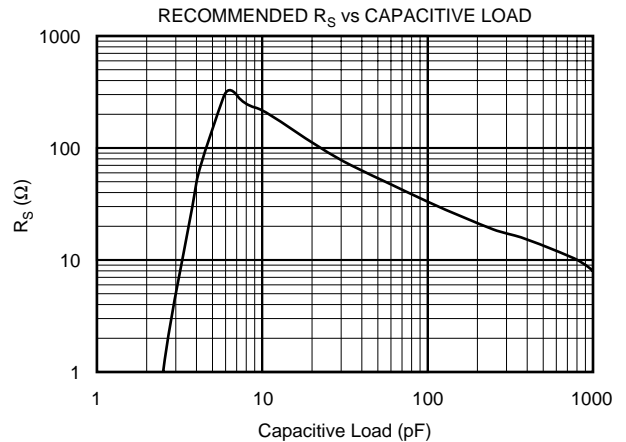
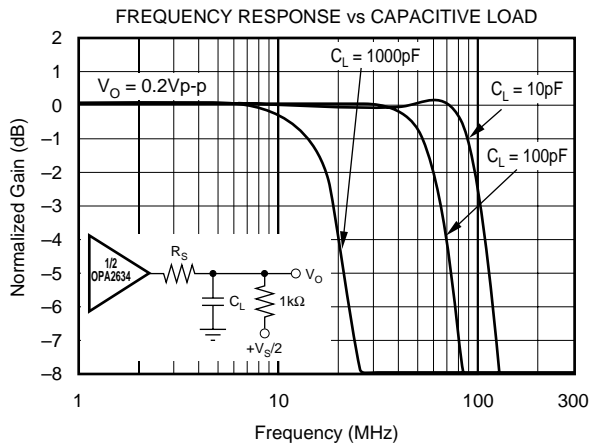
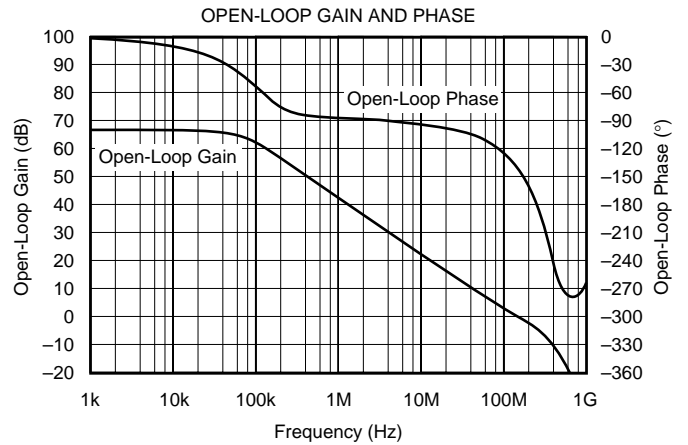
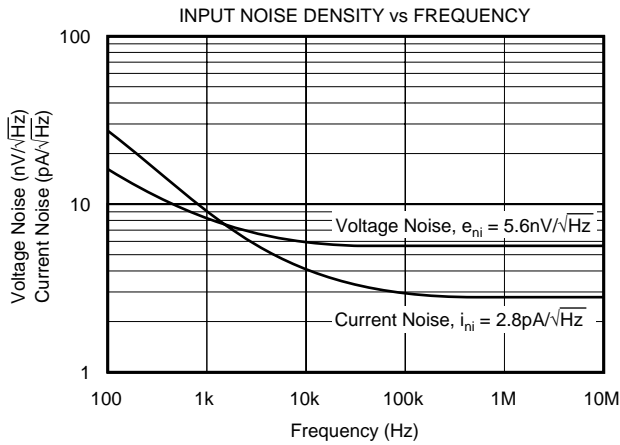
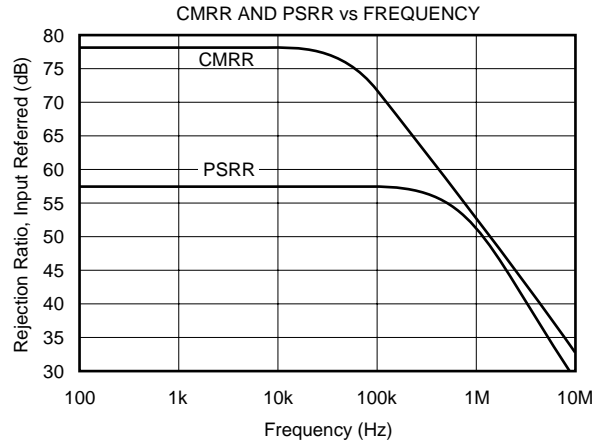
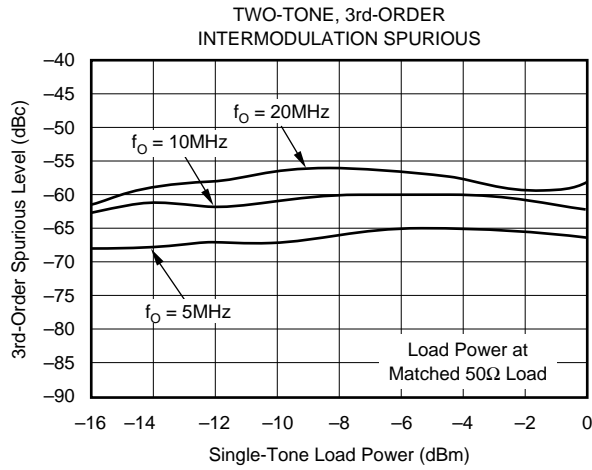

# TYPICAL PERFORMANCE CURVES: $V_S = +5V$ (Cont.)

At  $T_A = 25^\circ\text{C}$ ,  $G = +2$ ,  $R_F = 750\Omega$ , and  $R_L = 150\Omega$  to  $V_S/2$ , unless otherwise noted (see Figure 1).

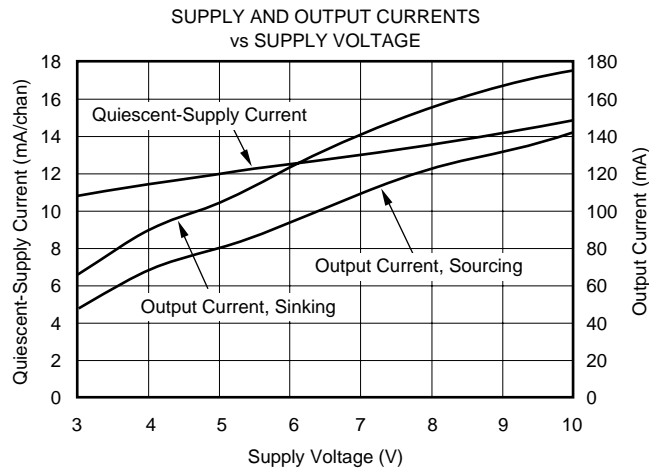
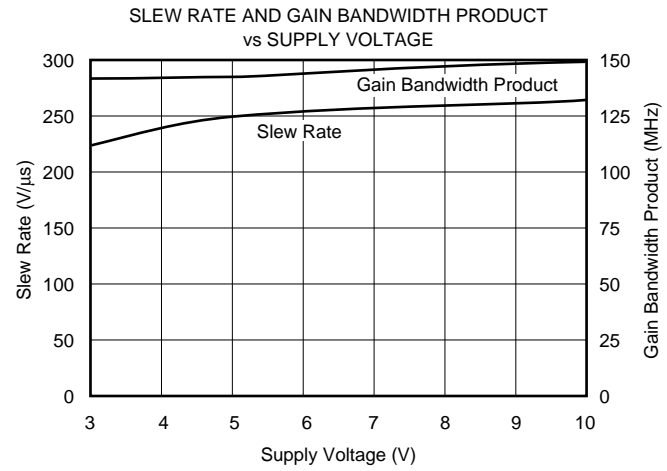
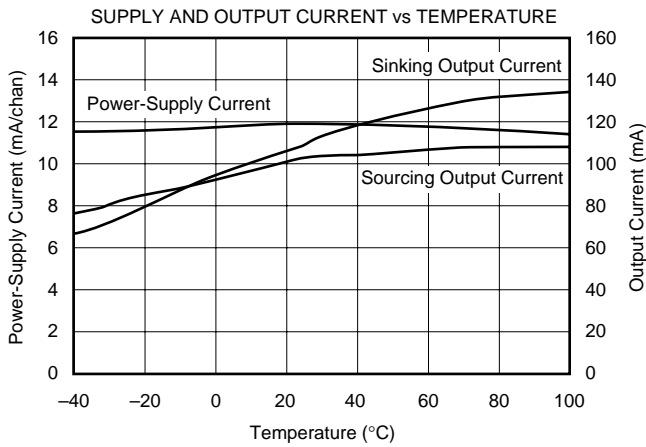
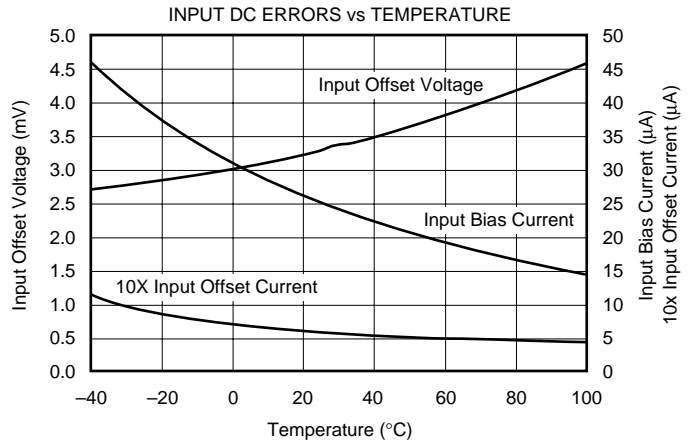
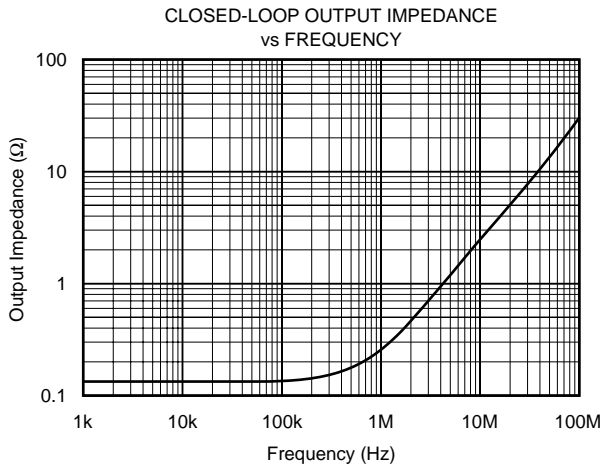



# TYPICAL PERFORMANCE CURVES: $V_S = +3V$

At  $T_A = 25^\circ C$ ,  $G = +2$ ,  $R_F = 750\Omega$ , and  $R_L = 150\Omega$  to  $V_S/2$ , unless otherwise noted (see Figure 2).

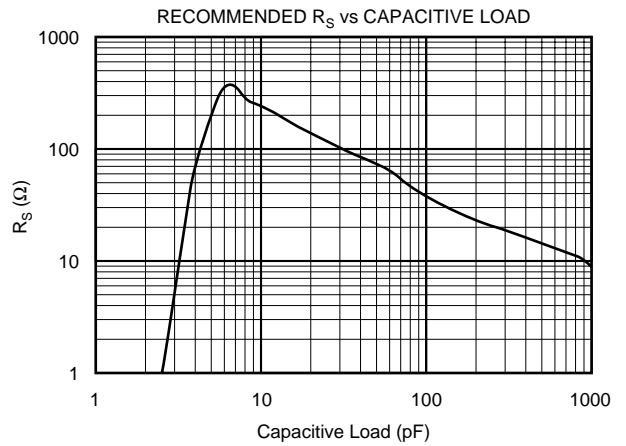
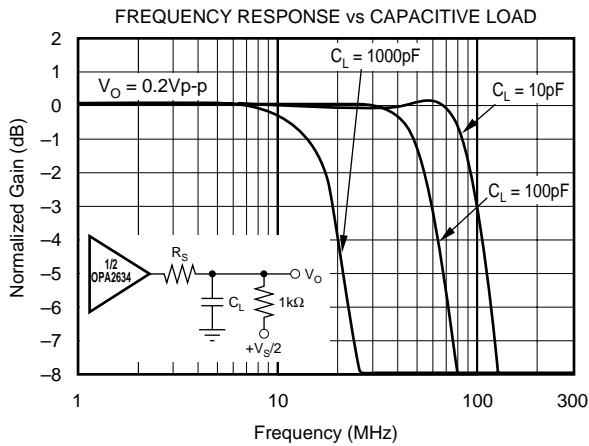
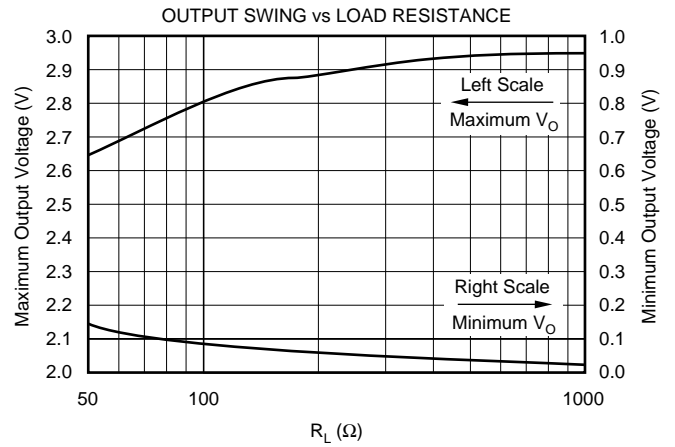
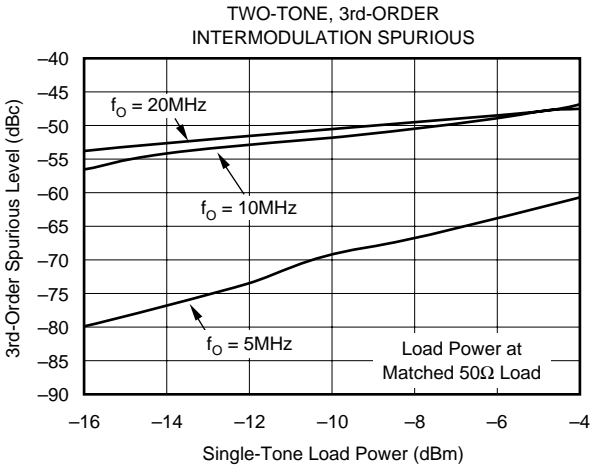
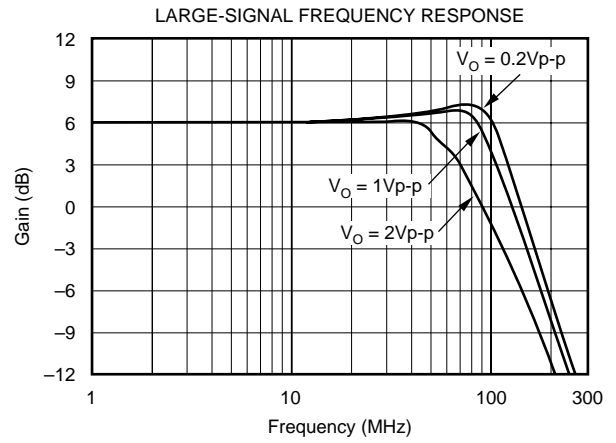
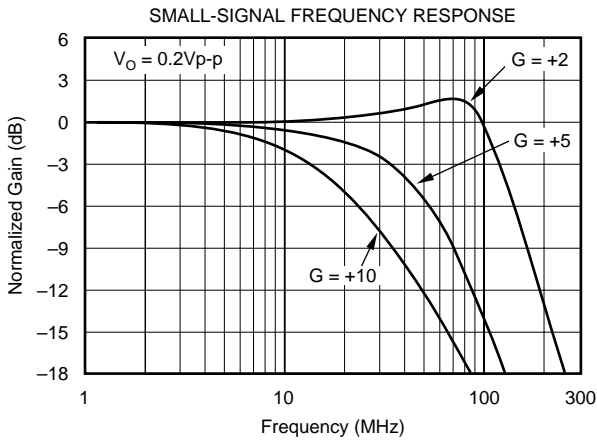

# APPLICATIONS INFORMATION

## WIDEBAND VOLTAGE FEEDBACK OPERATION

The OPA2634 is a unity-gain stable, very high-speed, voltage-feedback op amp designed for single-supply operation (+3V to +10V). The input stage supports input voltages below ground, and to within 1.2V of the positive supply. The complementary common-emitter output stage provides an output swing to within 30mV of ground and 140mV of the positive supply. It is compensated to provide stable operation with a wide range of resistive loads.

Figure 1 shows the AC-coupled, gain of +2 configuration used for the +5V Specifications and Typical Performance Curves. For test purposes, the input impedance is set to 50Ω with a resistor to ground. Voltage swings reported in the Specifications are taken directly at the input and output pins. For the circuit of Figure 1, the total effective load on the output at high frequencies is 150Ω || 1500Ω. The 1.50kΩ resistors at the non-inverting input provide the common-mode bias voltage. Their parallel combination equals the DC resistance at the inverting input, minimizing the DC offset.

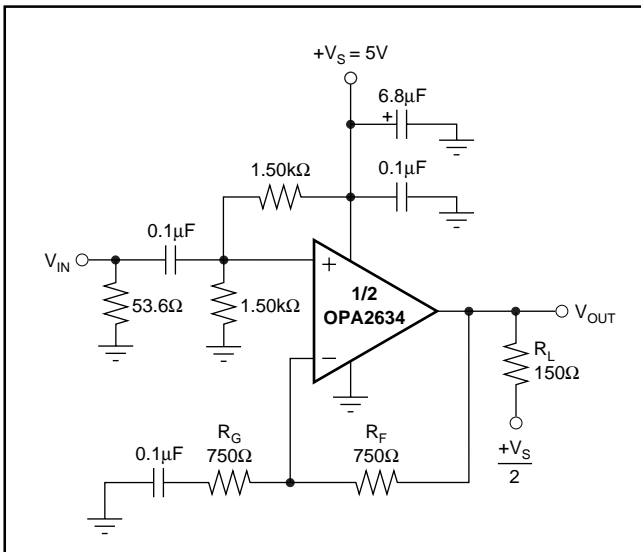

FIGURE 1. AC-Coupled Signal—Resistive Load to Supply Midpoint.

Figure 2 shows the DC-coupled, gain of +2 configuration used for the +3V Specifications and Typical Performance Curves. For test purposes, the input impedance is set to 50Ω with a resistor to ground. Though not strictly a “rail-to-rail” design, this part comes very close, while maintaining excellent performance. It will deliver up to 2.8Vp-p on a single +3V supply with > 60MHz bandwidth. The 374Ω and 2.26kΩ resistors at the input level-shift  $V_{IN}$  so that  $V_{OUT}$  is within the allowed output voltage range when  $V_{IN} = 0$ . See the typical performance curves for information on driving capacitive loads.

## SINGLE-SUPPLY ADC INTERFACE

The front page shows a DC-coupled, single-supply, dual ADC (Analog-to-Digital Converter) driver circuit. Many systems are now requiring +3V supply capability of both the

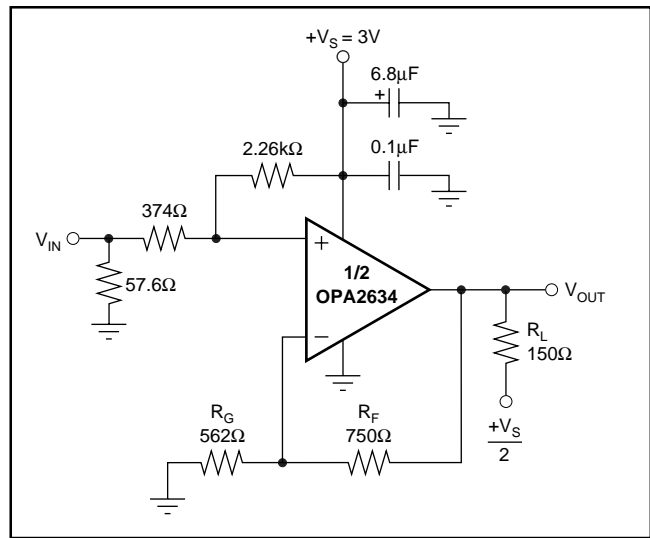

FIGURE 2. DC-Coupled Signal—Resistive Load to Supply Midpoint.

ADC and its driver. The OPA2634 provides excellent performance in this demanding application. Its large input and output voltage ranges, and low distortion, support converters such as the ADS900 shown in this figure. The input level-shifting circuitry was designed so that  $V_{IN}$  can be between 0V and 0.5V, while producing a 1V to 2V at the output pin for the ADS900.

## ANTI-ALIASING FILTER

Figure 3 shows an anti-aliasing filter, with a 5th-order Inverse Chebyshev response, based on a single OPA2634. This filter cascades two 2nd-order Sallen-Key sections with transmission zeros, and a real pole section followed by a simple real pole at the output. It has a -3dB frequency of 5MHz, and a -60dB stopband starting at 12MHz.

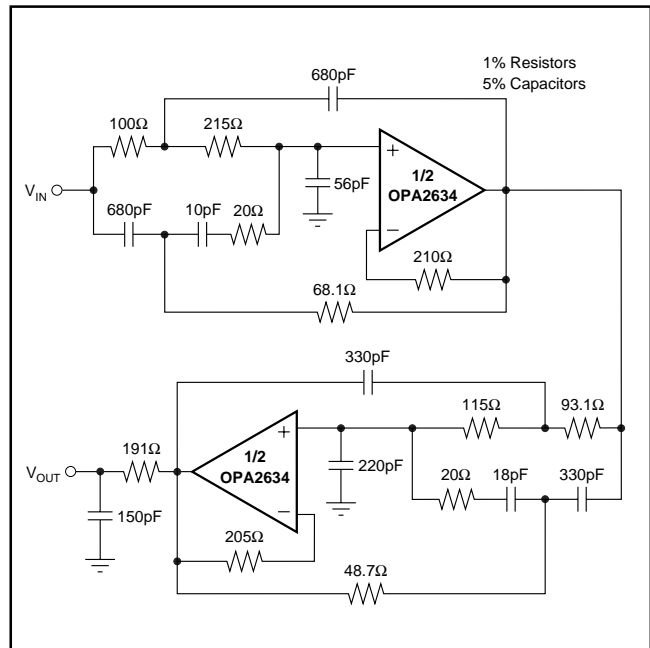

FIGURE 3. Inverse Chebyshev Anti-Aliasing Filter.

This filter works well on +5V or ±5V supplies, and with an Analog-to-Digital (A/D) converter at 20MSPS (e.g., ADS900).  $V_{IN}$  needs to be a very low impedance source, such as an op amp.

The filter transfer function was designed using Burr-Brown's FilterPro 42 design program (available at [www.ti.com](http://www.ti.com)) with a nominal stopband attenuation of 60dB. Table I gives the results ( $H_0$  = DC gain,  $f_p$  = pole frequency,  $Q_p$  = pole quality, and  $f_z$  = zero frequency). Note that the parameters were generated at  $f_{-3dB} = 5\text{Hz}$ , and then scaled to  $f_{-3dB} = 5\text{MHz}$ .

FILTER SECTION	$H_0$	$f_p$	$Q_p$	$f_z$
1	1V/V	5.04MHz	1.77	12.6MHz
2	1V/V	5.31MHz	0.64	20.4MHz
3	1V/V	5.50MHz	—	—

TABLE I. Nominal Filter Parameters.

The components were chosen to give this transfer function. The 20Ω resistors isolate the amplifier outputs from capacitive loading, but affect the response at very high frequencies only. Figure 4 shows the nominal response simulated by SPICE; it is very close to the ideal response.

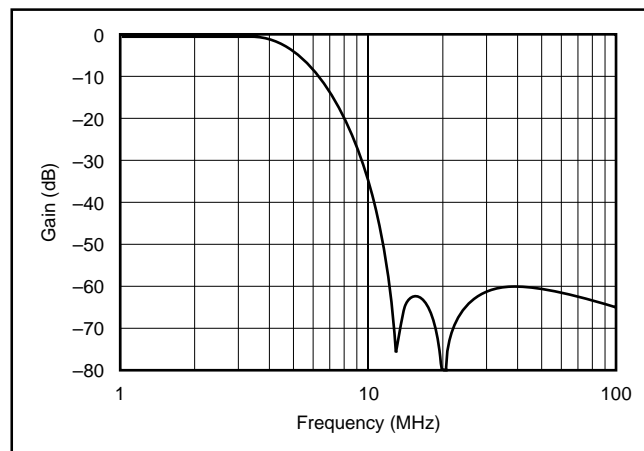

FIGURE 4. Nominal Filter Response.

## DC LEVEL-SHIFTING

Figure 5 shows a DC-coupled, non-inverting amplifier that level-shifts the input up to accommodate the desired output voltage range. Given the desired signal gain ( $G$ ), and the amount  $V_{OUT}$  needs to be shifted up ( $\Delta V_{OUT}$ ) when  $V_{IN}$  is at the center of its range, the following equations give the resistor values that produce the desired performance. Start by setting  $R_4$  between 200Ω and 1.5kΩ:

$$NG = G + \Delta V_{OUT}/V_S$$

$$R_1 = R_4/G$$

$$R_2 = R_4/(NG - G)$$

$$R_3 = R_4/(NG - 1)$$

where:

$$NG = 1 + R_4/R_3 \text{ (Noise Gain)}$$

$$V_{OUT} = (G)V_{IN} + (NG - G)V_S$$

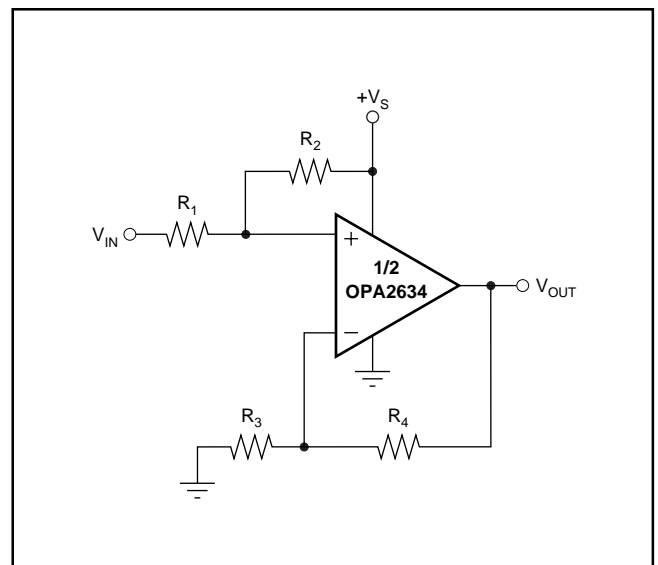

FIGURE 5. DC Level-Shifting Circuit.

Make sure that  $V_{IN}$  and  $V_{OUT}$  stay within the specified input and output voltage ranges.

The front-page circuit is a good example of this type of application. It was designed to take  $V_{IN}$  between 0V and 0.5V, and produce  $V_{OUT}$  between 1V and 2V, when using a +3V supply. This means  $G = 2$ , and  $\Delta V_{OUT} = 1.50\text{V} - G \cdot 0.25\text{V} = 1.00\text{V}$ . Plugging into the above equations (with  $R_4 = 750\Omega$ ) gives:  $NG = 2.33$ ,  $R_1 = 375\Omega$ ,  $R_2 = 2.25\text{k}\Omega$ , and  $R_3 = 563\Omega$ . The resistors were changed to the nearest standard values.

## NON-INVERTING AMPLIFIER WITH REDUCED PEAKING

Figure 6 shows a non-inverting amplifier that reduces peaking at low gains. The resistor  $R_C$  compensates the OPA2634 to have higher Noise Gain (NG), which reduces the AC response peaking (typically 5dB at  $G = +1$  without  $R_C$ ) without changing the DC gain.  $V_{IN}$  needs to be a low impedance source, such as an op amp. The resistor values are low to reduce noise. Using both  $R_T$  and  $R_F$  helps minimize the impact of parasitic impedances.

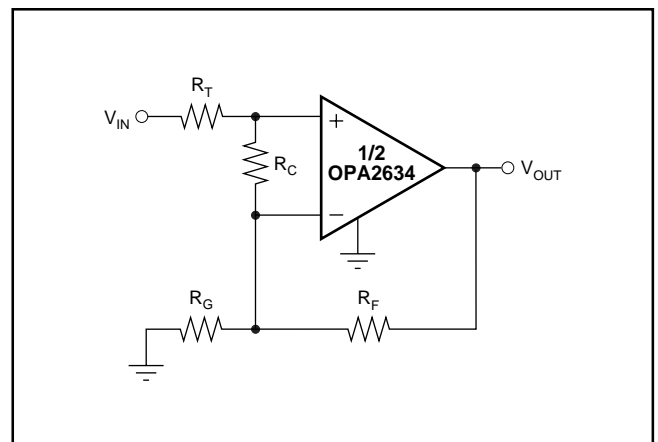

FIGURE 6. Compensated Non-Inverting Amplifier.

The noise gain can be calculated as follows:

$$G_1 = 1 + \frac{R_F}{R_G}$$

$$G_2 = 1 + \frac{R_T + R_F/G_1}{R_C}$$

$$NG = G_1 G_2$$

A unity-gain buffer can be designed by selecting  $R_T = R_F = 20.0\Omega$  and  $R_C = 40.2\Omega$  (do not use  $R_G$ ). This gives a noise gain of 2, therefore, its response will be similar to the typical performance curves with  $G = +2$ . Decreasing  $R_C$  to  $20.0\Omega$  will increase the noise gain to 3, which typically gives a flat frequency response, but with less bandwidth.

The circuit in Figure 2 can be redesigned to have less peaking by increasing the noise gain to 3. This is accomplished by adding  $R_C = 2.55k\Omega$  between the op amp's inputs.

## DESIGN-IN TOOLS

### DEMONSTRATION BOARDS

A PC board is available to assist in the initial evaluation of circuit performance using the OPA2634U. It is available free as an unpopulated PC board delivered with descriptive documentation. The summary information for this board is shown in Table II.

PRODUCT	PACKAGE	BOARD PART NUMBER	LITERATURE REQUEST NUMBER
OPA2634U	SO-8	DEM-OPA268xU	MKT-352

TABLE II. Demo Board Summary Information.

Contact the Texas Instruments Technical Applications Support Line at 1-972-644-5580 to request this board.

## OPERATING SUGGESTIONS

### OPTIMIZING RESISTOR VALUES

Since the OPA2634 is a voltage-feedback op amp, a wide range of resistor values may be used for the feedback and gain setting resistors. The primary limits on these values are set by dynamic range (noise and distortion) and parasitic capacitance considerations. For a non-inverting unity-gain follower application, the feedback connection should be

made with a  $20\Omega$  resistor, not a direct short. This will isolate the inverting input capacitance from the output pin and improve the frequency response flatness. Usually, for  $G > 1$  application, the feedback resistor value should be between  $200\Omega$  and  $1.5k\Omega$ . Below  $200\Omega$ , the feedback network will present additional output loading which can degrade the harmonic-distortion performance. Above  $1.5k\Omega$ , the typical parasitic capacitance (approximately  $0.2pF$ ) across the feedback resistor may cause unintentional bandlimiting in the amplifier response.

A good rule of thumb is to target the parallel combination of  $R_F$  and  $R_G$  (Figure 6) to be less than approximately  $400\Omega$ . The combined impedance ( $R_F \parallel R_G$ ) interacts with the inverting input capacitance, placing an additional pole in the feedback network and thus, a zero in the forward response. Assuming a  $3pF$  total parasitic on the inverting node, holding  $R_F \parallel R_G < 400\Omega$  will keep this pole above  $130MHz$ . By itself, this constraint implies that the feedback resistor ( $R_F$ ) can increase to several  $k\Omega$  at high gains. This is acceptable as long as the pole formed by  $R_F$ , and any parasitic capacitance appearing in parallel, is kept out of the frequency range of interest.

### BANDWIDTH VERSUS GAIN: NON-INVERTING OPERATION

Voltage-feedback op amps exhibit decreasing closed-loop bandwidth as the signal gain is increased. In theory, this relationship is described by the Gain Bandwidth Product (GBP) shown in the Specifications. Ideally, dividing GBP by the non-inverting signal gain (also called the Noise Gain, or NG) will predict the closed-loop bandwidth. In practice, this only holds true when the phase margin approaches  $90^\circ$ , as it does in high-gain configurations. At low gains (increased feedback factors), most amplifiers will exhibit a more complex response with lower phase margin. The OPA2634 is compensated to give a slightly peaked response in a non-inverting gain of 2 (Figure 1). This results in a typical gain of +2 bandwidth of  $150MHz$ , far exceeding that predicted by dividing the  $140MHz$  GBP by 2. Increasing the gain will cause the phase margin to approach  $90^\circ$  and the bandwidth to more closely approach the predicted value of (GBP/NG). At a gain of +10, the  $16MHz$  bandwidth shown in the Specifications is close to that predicted using the simple formula and the typical GBP.

The OPA2634 exhibits minimal bandwidth reduction going to +3V single-supply operation as compared with +5V supply. This is because the internal bias control circuitry retains nearly constant quiescent current as the total supply voltage between the supply pins is changed.

## INVERTING AMPLIFIER OPERATION

Since the OPA2634 is a general-purpose, wideband voltage-feedback op amp, all of the familiar op amp application circuits are available to the designer. Figure 7 shows a typical inverting configuration where the I/O impedances and signal gain from Figure 1 are retained in an inverting circuit configuration. Inverting operation is one of the more common requirements and offers several performance benefits. The inverting configuration shows improved slew rate and distortion. It also biases the input at  $V_S/2$  for the best headroom. The output voltage can be independently moved with bias-adjustment resistors connected to the inverting input.

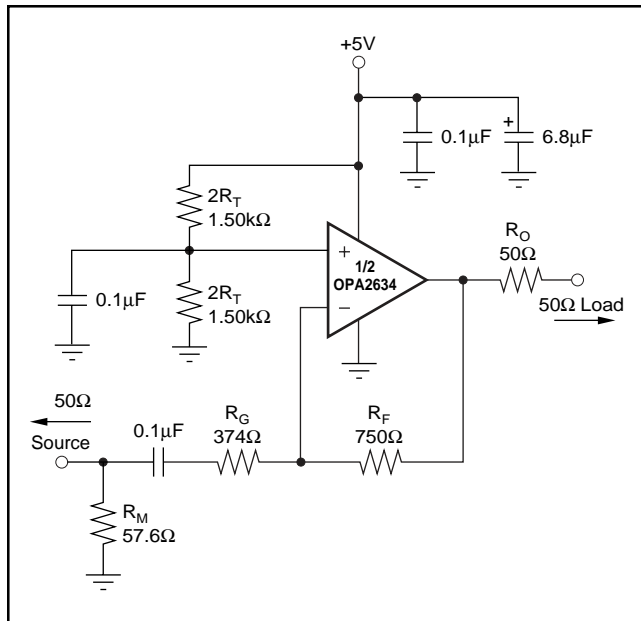

FIGURE 7. Gain of  $-2$  Example Circuit.

In the inverting configuration, three key design considerations must be noted. The first is that the gain resistor ( $R_G$ ) becomes part of the signal channel input impedance. If input impedance matching is desired (which is beneficial whenever the signal is coupled through a cable, twisted pair, long PC board trace, or other transmission line conductor),  $R_G$  may be set equal to the required termination value and  $R_F$  adjusted to give the desired gain. This is the simplest approach and results in optimum bandwidth and noise performance. However, at low inverting gains, the resultant feedback resistor value can present a significant load to the amplifier output. For an inverting gain of 2, setting  $R_G$  to  $50\Omega$  for input matching eliminates the need for  $R_M$  but requires a  $100\Omega$  feedback resistor. This has the interesting advantage of the noise gain becoming equal to 2 for a  $50\Omega$  source impedance—the same as the non-inverting circuits considered above. However, the amplifier output will now see the  $100\Omega$  feedback resistor in parallel with the external load. In general, the feedback resistor should be limited to the  $200\Omega$  to  $1.5k\Omega$  range. In this case, it is preferable to increase both the  $R_F$  and  $R_G$  values, as shown in Figure 7, and then achieve the input matching impedance with a third

resistor ( $R_M$ ) to ground. The total input impedance becomes the parallel combination of  $R_G$  and  $R_M$ .

The second major consideration, touched on in the previous paragraph, is that the signal source impedance becomes part of the noise gain equation and hence, influences the bandwidth. For the example in Figure 7, the  $R_M$  value combines in parallel with the external  $50\Omega$  source impedance, yielding an effective driving impedance of  $50\Omega \parallel 57.6\Omega = 26.8\Omega$ . This impedance is added in series with  $R_G$  for calculating the noise gain. The resultant is 2.87 for Figure 7, as opposed to only 2 if  $R_M$  could be eliminated as discussed above. The bandwidth will, therefore, be lower for the gain of  $-2$  circuit of Figure 7 ( $NG = +2.87$ ) than for the gain of  $+2$  circuit of Figure 1.

The third important consideration in inverting amplifier design is setting the bias current cancellation resistors on the non-inverting input (parallel combination of  $R_T = 750\Omega$ ). If this resistor is set equal to the total DC resistance looking out of the inverting node, the output DC error, due to the input bias currents, will be reduced to  $(\text{Input Offset Current}) \cdot R_F$ . Because of the  $0.1\mu\text{F}$  capacitor, the inverting input's bias current flows through  $R_F$ . Thus,  $R_T = 750\Omega = 1.50k\Omega \parallel 1.50k\Omega$  is needed for the minimum output offset voltage. To reduce the additional high-frequency noise introduced by  $R_T$ , and power-supply feedthrough, it is bypassed with a  $0.1\mu\text{F}$  capacitor. At a minimum, the OPA2634 should see a source resistance of at least  $50\Omega$  to damp out parasitic-induced peaking—a direct short to ground on the non-inverting input runs the risk of a very high-frequency instability in the input stage.

## OUTPUT CURRENT AND VOLTAGE

The OPA2634 provides outstanding output voltage capability. Under no-load conditions at  $+25^\circ\text{C}$ , the output voltage typically swings closer than  $140\text{mV}$  to either supply rail; the guaranteed over temperature swing is within  $300\text{mV}$  of either rail ( $V_S = +5\text{V}$ ).

The minimum specified output voltage and current specifications over temperature are set by worst-case simulations at the cold temperature extreme. Only at cold start-up will the output current and voltage decrease to the numbers shown in the guaranteed tables. As the output transistors deliver power, their junction temperatures will increase, decreasing their  $V_{BE}$ 's (increasing the available output voltage swing) and increasing their current gains (increasing the available output current). In steady-state operation, the available output voltage and current will always be greater than that shown in the over-temperature specifications, since the output stage junction temperatures will be higher than the minimum specified operating ambient.

To maintain maximum output stage linearity, no output short-circuit protection is provided. This will not normally be a problem, since most applications include a series matching resistor at the output that will limit the internal power dissipation if the output side of this resistor is shorted to ground.

## DRIVING CAPACITIVE LOADS

One of the most demanding and yet very common load conditions for an op amp is capacitive loading. Often, the capacitive load is the input of an ADC—including additional external capacitance which may be recommended to improve ADC linearity. A high-speed, high open-loop gain amplifier like the OPA2634 can be very susceptible to decreased stability and closed-loop response peaking when a capacitive load is placed directly on the output pin. When the primary considerations are frequency response flatness, pulse response fidelity, and/or distortion, the simplest and most effective solution is to isolate the capacitive load from the feedback loop by inserting a series isolation resistor between the amplifier output and the capacitive load.

The Typical Performance Curves show the recommended  $R_S$  versus capacitive load and the resulting frequency response at the load. Parasitic capacitive loads greater than 2pF can begin to degrade the performance of the OPA2634. Long PC board traces, unmatched cables, and connections to multiple devices can easily exceed this value. Always consider this effect carefully, and add the recommended series resistor as close as possible to the output pin (see Board Layout Guidelines section).

The criterion for setting this  $R_S$  resistor is a maximum bandwidth, flat frequency response at the load. For a gain of +2, the frequency response at the output pin is already slightly peaked without the capacitive load, requiring relatively high values of  $R_S$  to flatten the response at the load. Increasing the noise gain will also reduce the peaking, reducing the required  $R_S$  value (see Figure 6).

## DISTORTION PERFORMANCE

The OPA2634 provides good distortion performance into a 150Ω load. Relative to alternative solutions, it provides exceptional performance into lighter loads and/or operating on a single +3V supply. Generally, until the fundamental signal reaches very high frequency or power levels, the 2nd harmonic will dominate the distortion with a negligible 3rd harmonic component. Focusing then on the 2nd harmonic, increasing the load impedance improves distortion directly. Remember that the total load includes the feedback network; in the non-inverting configuration (Figure 1) this is sum of  $R_F + R_G$ , while in the inverting configuration, only  $R_F$  needs to be included in parallel with the actual load.

## NOISE PERFORMANCE

High slew rate, unity gain stable, voltage-feedback op amps usually achieve their slew rate at the expense of a higher input noise voltage. The 5.6nV/√Hz input voltage noise for the OPA2634 is, however, much lower than comparable

amplifiers. The input-referred voltage noise, and the two input-referred current noise terms (2.8pA/√Hz), combine to give low output noise under a wide variety of operating conditions. Figure 8 shows the op amp noise analysis model with all the noise terms included. In this model, all noise terms are taken to be noise voltage or current density terms in either nV/√Hz or pA/√Hz.

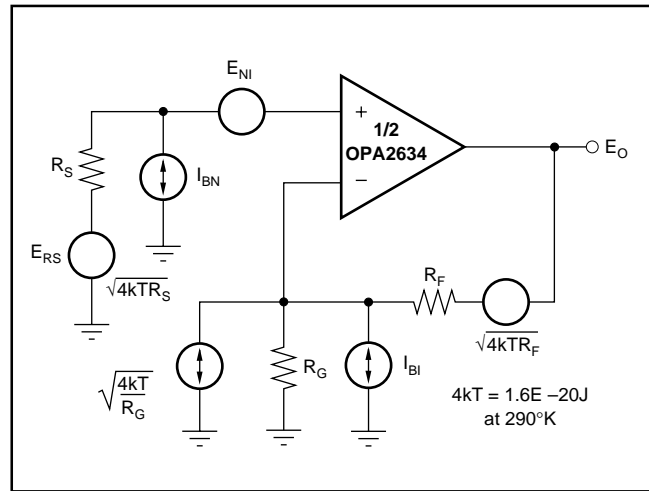

FIGURE 8. Noise Analysis Model.

The total output spot noise voltage can be computed as the square root of the sum of all squared output noise voltage contributors. Equation 1 shows the general form for the output noise voltage using the terms shown in Figure 8.

$$E_O = \sqrt{\left(E_{NI}^2 + (I_{BN}R_S)^2 + 4kTR_S\right)NG^2 + (I_{BI}R_F)^2 + 4kTR_F}NG \quad (1)$$

Dividing this expression by the noise gain ( $NG = (1 + R_F/R_G)$ ) will give the equivalent input-referred spot noise voltage at the non-inverting input, as shown in Equation 2.

$$E_N = \sqrt{E_{NI}^2 + (I_{BN}R_S)^2 + 4kTR_S + \left(\frac{I_{BI}R_F}{NG}\right)^2 + \frac{4kTR_F}{NG}} \quad (2)$$

Evaluating these two equations for the circuit and component values shown in Figure 1 will give a total output spot noise voltage of 12.5nV/√Hz and a total equivalent input spot noise voltage of 6.3nV/√Hz. This is including the noise added by the resistors. This total input-referred spot noise voltage is not much higher than the 5.6nV/√Hz specification for the op amp voltage noise alone. This will be the case as long as the impedances appearing at each op amp input are limited to the previously recommend maximum value of 400Ω, and the input attenuation is low.

## DC ACCURACY AND OFFSET CONTROL

The balanced input stage of a wideband voltage-feedback op amp allows good output DC accuracy in a wide variety of applications. The power-supply current trim for the OPA2634 gives even tighter control than comparable products. Although the high-speed input stage does require relatively high input bias current (typically 25µA out of each input terminal), the close matching between them may be used to reduce the output DC error caused by this current. This is done by matching the DC source resistances appearing at the two inputs. Evaluating the configuration of Figure 1 (which has matched DC input resistances), using worst-case +25°C input offset voltage and current specifications, gives a worst-case output offset voltage equal to (NG = non-inverting signal gain at DC):

$$\begin{aligned} & \pm(\text{NG} \cdot V_{\text{OS(MAX)}}) \pm (R_{\text{F}} \cdot I_{\text{OS(MAX)}}) \\ & = \pm(1 \cdot 7.0\text{mV}) \pm (750\Omega \cdot 2.25\mu\text{A}) \\ & = \pm 8.7\text{mV} \text{ [Output Offset Range for Figure 1]} \end{aligned}$$

A fine scale output offset null, or DC operating point adjustment, is often required. Numerous techniques are available for introducing DC offset control into an op amp circuit. Most of these techniques are based on adding a DC current through the feedback resistor. In selecting an offset trim method, one key consideration is the impact on the desired signal path frequency response. If the signal path is intended to be non-inverting, the offset control is best applied as an inverting summing signal to avoid interaction with the signal source. If the signal path is intended to be inverting, applying the offset control to the non-inverting input may be considered. Bring the DC offsetting current into the inverting input node through resistor values that are much larger than the signal path resistors. This will insure that the adjustment circuit has minimal effect on the loop gain and hence the frequency response.

## THERMAL ANALYSIS

Maximum desired junction temperature will set the maximum allowed internal power dissipation as described below. In no case should the maximum junction temperature be allowed to exceed 175°C.

Operating junction temperature ( $T_J$ ) is given by  $T_A + P_D \cdot \theta_{JA}$ . The total internal power dissipation ( $P_D$ ) is the sum of quiescent power ( $P_{DQ}$ ) and additional power dissipated in the output stage ( $P_{DL}$ ) to deliver load power. Quiescent power is simply the specified no-load supply current times the total supply voltage across the part.  $P_{DL}$  will depend on the required output signal and load but would, for resistive load connected to mid-supply ( $V_S/2$ ), be at a maximum when the output is fixed at a voltage equal to  $V_S/4$  or  $3V_S/4$ . Under this condition,  $P_{DL} = V_S^2 / (16 \cdot R_L)$ , where  $R_L$  includes feedback network loading.

Note that it is the power in the output stage, and not into the load, that determines internal power dissipation.

As a worst-case example, compute the maximum  $T_J$  using the circuit of Figure 1 operating at the maximum specified ambient temperature of +85°C and driving a 150Ω load at mid-supply, for both channels:

$$\begin{aligned} P_D &= 2 (10\text{V} \cdot 13.5\text{mA} + 5^2 / (16 \cdot (150\Omega \parallel 1500\Omega))) = 289\text{mW} \\ \text{Maximum } T_J &= +85^\circ\text{C} + (0.29\text{W} \cdot 125^\circ\text{C/W}) = 121^\circ\text{C} \end{aligned}$$

Although this is still well below the specified maximum junction temperature, system reliability considerations may require lower guaranteed junction temperatures. The highest possible internal dissipation will occur if the load requires current to be forced into the output at high output voltages or sourced from the output at low output voltages. This puts a high current through a large internal voltage drop in the output transistors.

## BOARD LAYOUT GUIDELINES

Achieving optimum performance with a high frequency amplifier like the OPA2634 requires careful attention to board layout parasitics and external component types. Recommendations that will optimize performance include:

**a) Minimize parasitic capacitance** to any AC ground for all of the signal I/O pins. Parasitic capacitance on the output and inverting input pins can cause instability: on the non-inverting input, it can react with the source impedance to cause unintentional bandlimiting. To reduce unwanted capacitance, a window around the signal I/O pins should be opened in all of the ground and power planes around those pins. Otherwise, ground and power planes should be unbroken elsewhere on the board.

**b) Minimize the distance** (< 0.25") from the power-supply pins to high frequency 0.1µF decoupling capacitors. At the device pins, the ground and power plane layout should not be in close proximity to the signal I/O pins. Avoid narrow power and ground traces to minimize inductance between the pins and the decoupling capacitors. Each power-supply connection should always be decoupled with one of these capacitors. An optional supply decoupling capacitor (0.1µF) across the two power supplies (for bipolar operation) will improve 2nd-harmonic distortion performance. Larger (2.2µF to 6.8µF) decoupling capacitors, effective at lower frequency, should also be used on the main supply pins. These may be placed somewhat farther from the device and may be shared among several devices in the same area of the PC board.

**c) Careful selection and placement of external components will preserve the high frequency performance.** Resistors should be a very low reactance type. Surface-mount resistors work best and allow a tighter overall layout. Metal film or carbon composition axially-leaded resistors can also provide good high-frequency performance. Again,

keep their leads and PC board traces as short as possible. Never use wirewound type resistors in a high frequency application. Since the output pin and inverting input pin are the most sensitive to parasitic capacitance, always position the feedback and series output resistor, if any, as close as possible to the output pin. Other network components, such as non-inverting input termination resistors, should also be placed close to the package. Where double-side component mounting is allowed, place the feedback resistor directly under the package on the other side of the board between the output and inverting input pins. Even with a low parasitic capacitance shunting the external resistors, excessively high resistor values can create significant time constants that can degrade performance. Good axial metal film or surface-mount resistors have approximately 0.2pF in shunt with the resistor. For resistor values  $> 1.5k\Omega$ , this parasitic capacitance can add a pole and/or zero below 500MHz that can effect circuit operation. Keep resistor values as low as possible consistent with load driving considerations. The  $750\Omega$  feedback used in the typical performance specifications is a good starting point for design.

**d) Connections to other wideband devices** on the board may be made with short direct traces or through on-board transmission lines. For short connections, consider the trace and the input to the next device as a lumped capacitive load. Relatively wide traces (50mils to 100mils) should be used, preferably with ground and power planes opened up around them. Estimate the total capacitive load and set  $R_S$  from the typical performance curve “Recommended  $R_S$  vs Capacitive Load”. Low parasitic capacitive loads ( $< 5pF$ ) may not need an  $R_S$  since the OPA2634 is nominally compensated to operate with a 2pF parasitic load. Higher parasitic capacitive loads without an  $R_S$  are allowed as the signal gain increases (increasing the unloaded phase margin). If a long trace is required, and the 6dB signal loss intrinsic to a doubly-terminated transmission line is acceptable, implement a matched impedance transmission line using microstrip or stripline techniques (consult an ECL design handbook for microstrip and stripline layout techniques). A  $50\Omega$  environment is normally not necessary on board, and in fact, a higher impedance environment will improve distortion as shown in the distortion versus load plots. With a characteristic board trace impedance defined (based on board material and trace dimensions), a matching series resistor into the trace from the output of the OPA2634 is used as well as a terminating shunt resistor at the input of the destination device. Remember also that the terminating impedance will be the parallel combination of the shunt resistor and the

input impedance of the destination device; this total effective impedance should be set to match the trace impedance. If the 6dB attenuation of a doubly-terminated transmission line is unacceptable, a long trace can be series-terminated at the source end only. Treat the trace as a capacitive load in this case and set the series resistor value as shown in the typical performance curve “Recommended  $R_S$  vs Capacitive Load”. This will not preserve signal integrity as well as a doubly-terminated line. If the input impedance of the destination device is low, there will be some signal attenuation due to the voltage divider formed by the series output into the terminating impedance.

**e) Socketing a high-speed part is not recommended.** The additional lead length and pin-to-pin capacitance introduced by the socket can create an extremely troublesome parasitic network which can make it almost impossible to achieve a smooth, stable frequency response. Best results are obtained by soldering the OPA2634 onto the board.

## INPUT AND ESD PROTECTION

The OPA2634 is built using a very high-speed complementary bipolar process. The internal junction breakdown voltages are relatively low for these very small geometry devices. These breakdowns are reflected in the Absolute Maximum Ratings table. All device pins are protected with internal ESD protection diodes to the power supplies, as shown in Figure 9.

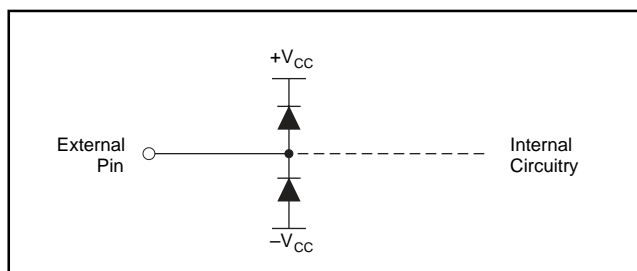

FIGURE 9. Internal ESD Protection.

These diodes provide moderate protection to input overdrive voltages above the supplies as well. The protection diodes can typically support 30mA continuous current. Where higher currents are possible (e.g., in systems with  $\pm 15V$  supply parts driving into the OPA2634), current-limiting series resistors should be added into the two inputs. Keep these resistor values as low as possible, since high values degrade both noise performance and frequency response.



## IMPORTANT NOTICE

Texas Instruments Incorporated and its subsidiaries (TI) reserve the right to make corrections, modifications, enhancements, improvements, and other changes to its products and services at any time and to discontinue any product or service without notice. Customers should obtain the latest relevant information before placing orders and should verify that such information is current and complete. All products are sold subject to TI's terms and conditions of sale supplied at the time of order acknowledgment.

TI warrants performance of its hardware products to the specifications applicable at the time of sale in accordance with TI's standard warranty. Testing and other quality control techniques are used to the extent TI deems necessary to support this warranty. Except where mandated by government requirements, testing of all parameters of each product is not necessarily performed.

TI assumes no liability for applications assistance or customer product design. Customers are responsible for their products and applications using TI components. To minimize the risks associated with customer products and applications, customers should provide adequate design and operating safeguards.

TI does not warrant or represent that any license, either express or implied, is granted under any TI patent right, copyright, mask work right, or other TI intellectual property right relating to any combination, machine, or process in which TI products or services are used. Information published by TI regarding third-party products or services does not constitute a license from TI to use such products or services or a warranty or endorsement thereof. Use of such information may require a license from a third party under the patents or other intellectual property of the third party, or a license from TI under the patents or other intellectual property of TI.

Reproduction of TI information in TI data books or data sheets is permissible only if reproduction is without alteration and is accompanied by all associated warranties, conditions, limitations, and notices. Reproduction of this information with alteration is an unfair and deceptive business practice. TI is not responsible or liable for such altered documentation. Information of third parties may be subject to additional restrictions.

Resale of TI products or services with statements different from or beyond the parameters stated by TI for that product or service voids all express and any implied warranties for the associated TI product or service and is an unfair and deceptive business practice. TI is not responsible or liable for any such statements.

TI products are not authorized for use in safety-critical applications (such as life support) where a failure of the TI product would reasonably be expected to cause severe personal injury or death, unless officers of the parties have executed an agreement specifically governing such use. Buyers represent that they have all necessary expertise in the safety and regulatory ramifications of their applications, and acknowledge and agree that they are solely responsible for all legal, regulatory and safety-related requirements concerning their products and any use of TI products in such safety-critical applications, notwithstanding any applications-related information or support that may be provided by TI. Further, Buyers must fully indemnify TI and its representatives against any damages arising out of the use of TI products in such safety-critical applications.

TI products are neither designed nor intended for use in military/aerospace applications or environments unless the TI products are specifically designated by TI as military-grade or "enhanced plastic." Only products designated by TI as military-grade meet military specifications. Buyers acknowledge and agree that any such use of TI products which TI has not designated as military-grade is solely at the Buyer's risk, and that they are solely responsible for compliance with all legal and regulatory requirements in connection with such use.

TI products are neither designed nor intended for use in automotive applications or environments unless the specific TI products are designated by TI as compliant with ISO/TS 16949 requirements. Buyers acknowledge and agree that, if they use any non-designated products in automotive applications, TI will not be responsible for any failure to meet such requirements.

Following are URLs where you can obtain information on other Texas Instruments products and application solutions:

### Products

Amplifiers	<a href="http://amplifier.ti.com">amplifier.ti.com</a>
Data Converters	<a href="http://dataconverter.ti.com">dataconverter.ti.com</a>
DSP	<a href="http://dsp.ti.com">dsp.ti.com</a>
Clocks and Timers	<a href="http://www.ti.com/clocks">www.ti.com/clocks</a>
Interface	<a href="http://interface.ti.com">interface.ti.com</a>
Logic	<a href="http://logic.ti.com">logic.ti.com</a>
Power Mgmt	<a href="http://power.ti.com">power.ti.com</a>
Microcontrollers	<a href="http://microcontroller.ti.com">microcontroller.ti.com</a>
RFID	<a href="http://www.ti-rfid.com">www.ti-rfid.com</a>
RF/IF and ZigBee® Solutions	<a href="http://www.ti.com/lprf">www.ti.com/lprf</a>

### Applications

Audio	<a href="http://www.ti.com/audio">www.ti.com/audio</a>
Automotive	<a href="http://www.ti.com/automotive">www.ti.com/automotive</a>
Broadband	<a href="http://www.ti.com/broadband">www.ti.com/broadband</a>
Digital Control	<a href="http://www.ti.com/digitalcontrol">www.ti.com/digitalcontrol</a>
Medical	<a href="http://www.ti.com/medical">www.ti.com/medical</a>
Military	<a href="http://www.ti.com/military">www.ti.com/military</a>
Optical Networking	<a href="http://www.ti.com/opticalnetwork">www.ti.com/opticalnetwork</a>
Security	<a href="http://www.ti.com/security">www.ti.com/security</a>
Telephony	<a href="http://www.ti.com/telephony">www.ti.com/telephony</a>
Video & Imaging	<a href="http://www.ti.com/video">www.ti.com/video</a>
Wireless	<a href="http://www.ti.com/wireless">www.ti.com/wireless</a>

Mailing Address: Texas Instruments, Post Office Box 655303, Dallas, Texas 75265  
Copyright © 2008, Texas Instruments Incorporated