

REVISIONS			
REV.	DESCRIPTION	DATE	APPROVED
A	INITIAL RELEASE	12/21/09	D.N.

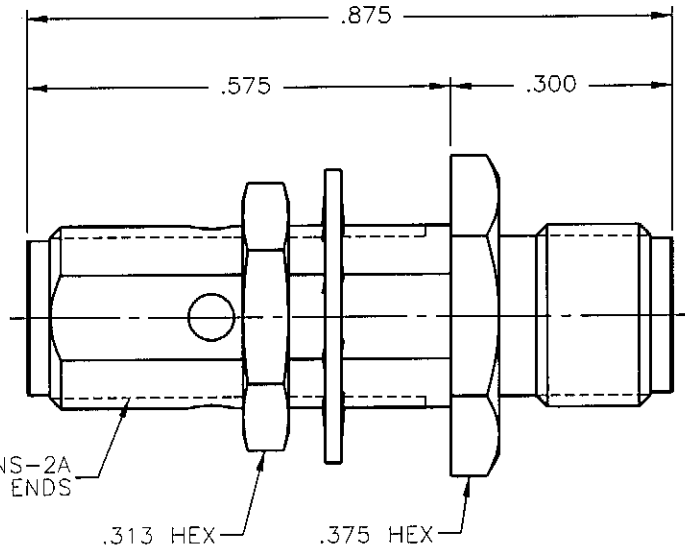
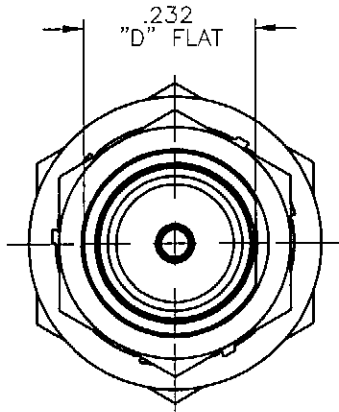

1/4-36 UNS-2A
BOTH ENDS

NOTES: CONFORMS TO MIL-C-39012 SMA SERIES

MATERIALS:

1. BODY & NUT = STAINLESS STEEL PER ASTM A582, ALLOY 303, CONDITION "A".
2. INSULATOR = VIRGIN WHITE TEFLON PER ASTM D1710, GRADE 1, TYPE I, CLASS "B".
3. CONTACT = BERYLLIUM COPPER PER ASTM B196, ALLOY C17300, TEMPER TD04.
4. LOCKWASHER = PHOSPHOR BRONZE PER ASTM B139, COPPER ALLOY C53400, TEMPER H04.

FINISHES:

1. BODY & NUT = PASSIVATE PER QQ-P-35, TYPE VI.
2. CONTACT = GOLD PLATE PER MIL-G-45204, TYPE II, CLASS 1, GRADE C, OVER .00010 TO .00020 STRESS FREE SULFAMATE NICKEL PER QQ-N-290.
3. LOCKWASHER = NICKEL PLATE PER QQ-N-290, CLASS 1, GRADE G, EXCEPT .0001 TO .0002 THICK OVER .00005 TO .0001 THICK COPPER PER MIL-C-14550.

Property of Radiall Incorporated
This document cannot be reproduced or
communicated to a third party without prior
written permission of RADIALL Incorporated.

UNLESS OTHERWISE SPECIFIED DIMENSIONS ARE IN INCHES TOLERANCES ON		DWN: D.N.	DATE 12/21/09	 APPLIED ENGINEERING PRODUCTS a RADIALL company 104 John W. Murphy Dr. New Haven, CT 06513
DECIMAL	ANGLE	CHKD: A.D.M.	DATE 12/21/09	
		APVD: J.M.	DATE 12/21/09	
REFERENCE:		MATERIALS & FINISHES:		SMA STRAIGHT BULKHEAD MOUNT JACK TO JACK ADAPTOR
ORIGINATED: D.N. DATE: 12/21/09		SEE NOTES		
SIZE A	FSCM NO. 19505	DWG NO. 5909-9103-000	REV A	
SCALE 4:1		THIRD ANGLE PROJECTION		SHEET 1 OF 1

5909-9103-000