

9850 | GEN II SERIES

ROTARY POSITION SENSOR

Introduction

The 9850 Gen II Series offers a highly reliable rotary potentiometer sensor module that can be easily integrated into a wide variety of space-conscious applications requiring installation simplicity, long service life and repeatable accuracy. The 9850 Gen II Series introduces a new, lower profile (15.2mm; maximum connector receptacle height 25.9mm), designed to perform in demanding environments.

Manufactured for optimal cost-economies, the 9850 Gen II Series offers simple yet durable design strengths that can lead to significant systems costs savings. Plug-in simplicity and sealed connector contact is assured via an integral right-angle connector receptacle designed to accept industry-standard Packard Electric METRI-Pack™ connectors. This design also eliminates weak/stress points and leaks in exposure to water.

Twelve standard models offer a choice of 180° or 120° mechanical rotation with round or slotted mounting holes for optimal installation alignment.



Features

- Dual-output offers the added functionality of two sensors in a single sensor
- Sealed integral interface accepts industry-standard Packard Electric METRI-Pack™ connectors
- Low-profile design answers space-conscious applications
- Additional mechanical rotation angles available

SPECIFICATIONS

Electrical

Active Electrical Rotation	85° or 130° Single Output (See Fig. 1) 85° Dual Output
Total Resistance	5,000 ohms ±20%
Linearity	Std. ±2.0% over active electrical rotation (See Fig. 1) (Independent) Spec. ±0.5% over active electrical rotation
Power Rating At 70°C	0.15 Watts

Mechanical

Mechanical Rotation (Nominal)	120°-180° single; 120° dual (See Table A)
Shaft Rotation/Direction	(See Table A)
Mechanical Life	1,000,000 full cycles 5,000,000 dither cycles
Stop Strength	0.68 Nm max.
Torque	0.11 Nm max
Mounting Torque	1.35 Nm max.

Environmental

Temperature Limits	-40°C to +125°C
Vibration	15 Gs, 50 to 1,000 Hz
Humidity	95% @ 40°C
Shock	50 Gs max.

 **INTEGRATES PROPRIETARY THICK FILM ELEMENT & PRECIOUS METAL CONTACT TECHNOLOGY WITH MAXIMUM PACKAGING FLEXIBILITY**

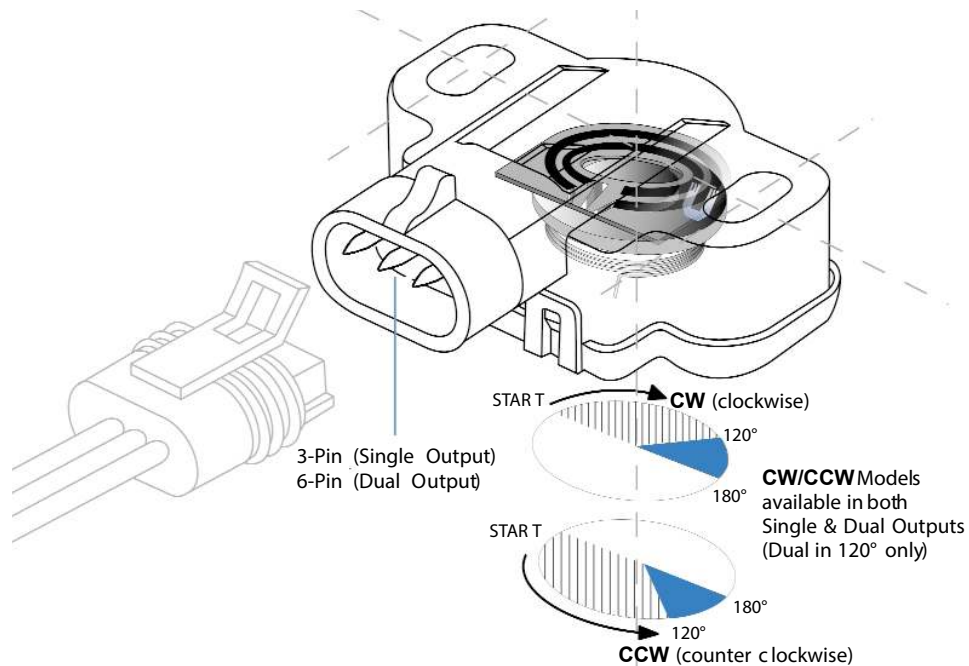
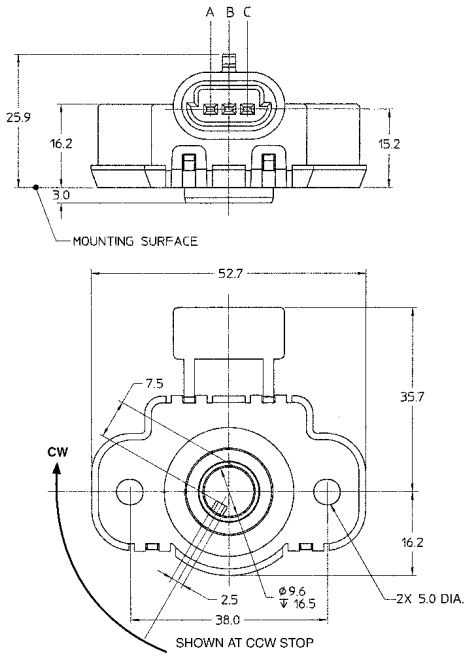

Fig.1

Models 9851-9858 – Single Output (3-Pin)



Models 9861-9864 – Dual Output (6-Pin)

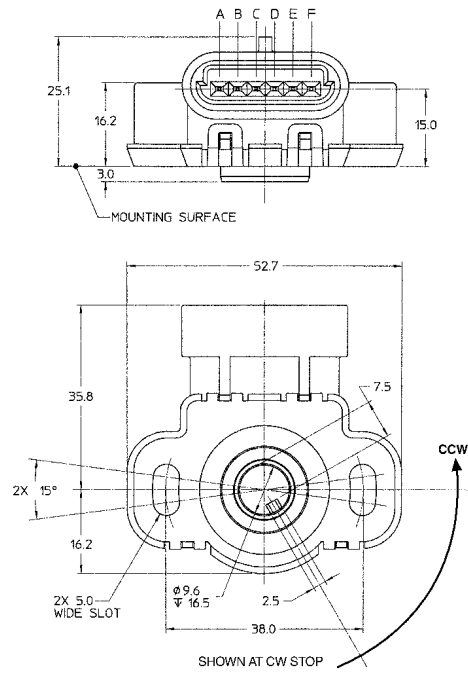
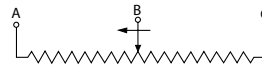

Table A

Model	Mechanical Rotation	Active Electrical Rotation	Rotation* Direction	Mounting ¹ Hole
9851	120°	85°	CW	S
9852	120°	85°	CCW	S
9853	120°	85°	CW	R
9854	120°	85°	CCW	R
9855	180°	130°	CW	S
9856	180°	130°	CCW	S
9857	180°	130°	CW	R
9858	180°	130°	CCW	R

Model	Mechanical Rotation	Active Electrical Rotation	Rotation* Direction	Mounting ¹ Hole
9861	120°	85°	CW	S
9862	120°	85°	CCW	S
9863	120°	85°	CW	R
9864	120°	85°	CCW	R

Single Output (3-pin)



Dual Output (6-pin)

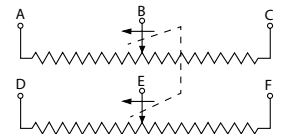
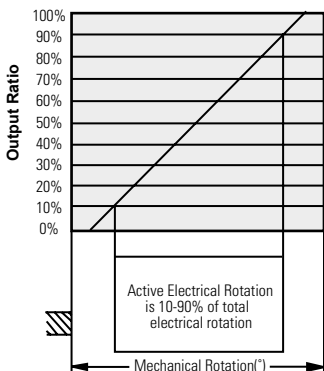

Fig.2



Note: For rotation outside active electrical rotation, linearity may exceed specified tolerances.

Mating Connector/Interface Information:

Sensor mates with Packard Electric METRI-Pack™ Series 150 Connectors

ORDERING OPTIONS

Example : 9855 R5K L2.0

Specifies a model 9855 (180° mechanical rotation, CW rotation direction) single output, 3-Pin Sensor Module with slotted mounting holes, standard resistance 5K ohms $\pm 20\%$, Linearity $\pm 2\%$.

Family

98XX:9851	9858
9852	9861
9853	9862
9854	9863
9855	9864
9856	

Standard Resistance

R5K

Standard Linearity (%)

L2.0

WARNINGS



RISK OF MATERIAL DAMAGE AND HOT ENCLOSURE

- The product's side panels may be hot, allow the product to cool before touching
- Follow proper mounting instructions including torque values
- Do not allow liquids or foreign objects to enter this product

Failure to follow these instructions can result in serious injury, or equipment damage.



HAZARD OF ELECTRIC SHOCK, EXPLOSION OR ARC FLASH

- Disconnect all power before installing or working with this equipment
- Verify all connections and replace all covers before turning on power

Failure to follow these instructions will result in death or serious injury.

Sensata Technologies, Inc. ("Sensata") data sheets are solely intended to assist designers ("Buyers") who are developing systems that incorporate Sensata products (also referred to herein as "components"). Buyer understands and agrees that Buyer remains responsible for using its independent analysis, evaluation and judgment in designing Buyer's systems and products. Sensata data sheets have been created using standard laboratory conditions and engineering practices. Sensata has not conducted any testing other than that specifically described in the published documentation for a particular data sheet. Sensata may make corrections, enhancements, improvements and other changes to its data sheets or components without notice.

Buyers are authorized to use Sensata data sheets with the Sensata component(s) identified in each particular data sheet. HOWEVER, NO OTHER LICENSE, EXPRESS OR IMPLIED, BY ESTOPPEL OR OTHERWISE TO ANY OTHER SENSATA INTELLECTUAL PROPERTY RIGHT, AND NO LICENSE TO ANY THIRD PARTY TECHNOLOGY OR INTELLECTUAL PROPERTY RIGHT, IS GRANTED HEREIN. SENSATA DATA SHEETS ARE PROVIDED "AS IS". SENSATA MAKES NO WARRANTIES OR REPRESENTATIONS WITH REGARD TO THE DATA SHEETS OR USE OF THE DATA SHEETS, EXPRESS, IMPLIED OR STATUTORY, INCLUDING ACCURACY OR COMPLETENESS. SENSATA DISCLAIMS ANY WARRANTY OF TITLE AND ANY IMPLIED WARRANTIES OF MERCHANTABILITY, FITNESS FOR A PARTICULAR PURPOSE, QUIET ENJOYMENT, QUIET POSSESSION, AND NON-INFRINGEMENT OF ANY THIRD PARTY INTELLECTUAL PROPERTY RIGHTS WITH REGARD TO SENSATA DATA SHEETS OR USE THEREOF.

All products are sold subject to Sensata's terms and conditions of sale supplied at www.sensata.com SENSATA ASSUMES NO LIABILITY FOR APPLICATIONS ASSISTANCE OR THE DESIGN OF BUYERS' PRODUCTS. BUYER ACKNOWLEDGES AND AGREES THAT IT IS SOLELY RESPONSIBLE FOR COMPLIANCE WITH ALL LEGAL, REGULATORY AND SAFETY-RELATED REQUIREMENTS CONCERNING ITS PRODUCTS, AND ANY USE OF SENSATA COMPONENTS IN ITS APPLICATIONS, NOTWITHSTANDING ANY APPLICATIONS-RELATED INFORMATION OR SUPPORT THAT MAY BE PROVIDED BY SENSATA.

Mailing Address: Sensata Technologies, Inc., 529 Pleasant Street, Attleboro, MA 02703, USA.

CONTACT US

Americas

+1 (800) 350 2727
sensors@sensata.com

Europe, Middle East & Africa

+33 (3) 88 20 8080
position-info.eu@sensata.com

Asia Pacific

sales.isasia@list.sensata.com
 China +86 (21) 2306 1500
 Japan +81 (45) 277 7117
 Korea +82 (31) 601 2004
 India +91 (80) 67920890
 Rest of Asia +886 (2) 27602006
 ext 2808