

Introduction

The STM320518-EVAL evaluation board is designed as a complete demonstration and development platform for STMicroelectronic's ARM cortex-M0 core-based STM32F051R8T6 microcontroller. It features two I2Cs, two SPIs, two USARTs, a 12-bit ADC, a 12-bit DAC, two GP comparators, internal 8 KB SRAM and 64 KB Flash, touch sensing, CEC and SWD debugging support.

The full range of hardware features on the board is able to help you evaluate all peripherals (motor control connector, RS-232, RS-485, audio DAC, linear sensor, microphone ADC, TFT LCD, IrDA, IR LED, IR receiver, LDR, MicroSD card, CEC on two HDMI connectors, RF E2PROM, temperature sensor and so on) and develop your own applications. Extension headers make it possible to easily connect a daughterboard or wrapping board for your specific application.

An ST-LINK/V2 is integrated on the board as an embedded in-circuit debugger and programmer for the STM32 MCU.

Figure 1. STM320518-EVAL evaluation board



Table 1. Applicable tools

Type	Part number
Evaluation tools	STM320518-EVAL

Contents

- 1 Overview 6**
 - 1.1 Features 6
 - 1.2 Demonstration software 6
 - 1.3 Order code 6
 - 1.4 Delivery recommendations 7

- 2 Hardware layout and configuration 8**
 - 2.1 Development and debug support 10
 - 2.2 Power supply 11
 - 2.3 Clock source 13
 - 2.4 Reset source 13
 - 2.5 Boot option 14
 - 2.6 Audio 14
 - 2.7 RS-232, RS-485 and IrDA 15
 - 2.8 Linear sensor 16
 - 2.9 MicroSD card 16
 - 2.10 Analog input 16
 - 2.11 LDR (light dependent resistor) 16
 - 2.12 Temperature sensor 17
 - 2.13 Display and input devices 17
 - 2.14 RF E2PROM 18
 - 2.15 HDMI CEC 18
 - 2.16 IR LED and IR receiver 19
 - 2.17 Motor control 19

- 3 Connector 22**
 - 3.1 Motor control connector CN1 22
 - 3.2 RF E2PROM connector CN2 23
 - 3.3 HDMI sink connector CN3 23
 - 3.4 HDMI source connector CN4 24
 - 3.5 Daughterboard extension connector CN5 and CN6 24

3.6	RS-232 and RS-485 connector CN7	27
3.7	Analog input connector CN8	28
3.8	High density SWD connector CN9	28
3.9	Standard SWD connector CN10	29
3.10	Audio jack CN11	29
3.11	ST-LINK/V2 programming connector CN12	29
3.12	ST-LINK/V2 USB type B connector CN13	29
3.13	MicroSD connector CN14	30
3.14	Power connector CN15	31
4	Board schematics	32
Appendix A	STM320518-EVAL I/O assignments	47
Appendix B	Mechanical dimensions.	50
Revision history		51

List of tables

Table 1.	Applicable tools	1
Table 2.	Third-party toolchain support	10
Table 3.	Power source related jumpers	11
Table 4.	Power mode related jumpers	12
Table 5.	8 MHz crystal X1 related solder bridges	13
Table 6.	32 kHz crystal X2 related solder bridges	13
Table 7.	Boot related switch	14
Table 8.	Boot0 related jumpers	14
Table 9.	Audio related jumpers	14
Table 10.	RS-232 and IrDA related jumpers	15
Table 11.	RS-485 related solder bridges	16
Table 12.	LCD modules	17
Table 13.	Motor control related jumpers	21
Table 14.	Motor control connector CN1	22
Table 15.	RF E2PROM connector CN2	23
Table 16.	HDMI sink connector CN3	24
Table 17.	HDMI source connector CN4	24
Table 18.	Daughterboard extension connector CN5	25
Table 19.	Daughterboard extension connector CN6	26
Table 20.	RS-232 and RS-485 connector CN7	27
Table 21.	Analog input-output connector CN8	28
Table 22.	High density SWD debugging connector CN9	28
Table 23.	Standard SWD debugging connector CN10	29
Table 24.	USB type B connector CN13	30
Table 25.	MicroSD connector CN14	30
Table 26.	STM32F051R8T6 MCU pin assignments	47
Table 27.	Mechanical dimensions	50
Table 28.	Document revision history	51

List of figures

Figure 1.	STM320518-EVAL evaluation board	1
Figure 2.	Hardware block diagram	8
Figure 3.	STM320518-EVAL evaluation board layout	9
Figure 4.	STM320518-EVAL evaluation board	17
Figure 5.	STM320518-EVAL evaluation board motor control PCB reworks	20
Figure 6.	Motor control connector CN1	22
Figure 7.	RF EEPROM daughterboard connector CN2	23
Figure 8.	HDMI sink connector CN3	23
Figure 9.	HDMI source connector CN4	24
Figure 10.	RS-232 and RS-485 connector	27
Figure 11.	Analog input-output connector CN8	28
Figure 12.	High density SWD debugging connector CN9	28
Figure 13.	Standard SWD debugging connector CN10	29
Figure 14.	USB type B connector CN13	30
Figure 15.	MicroSD connector CN14	30
Figure 16.	Power supply connector CN15	31
Figure 17.	STM320518-EVAL	33
Figure 18.	MCU	34
Figure 19.	Audio	35
Figure 20.	HDMI_CEC	36
Figure 21.	LCD and micro SD card	37
Figure 22.	Peripherals	38
Figure 23.	RS-232, RS-485 and IrDA	39
Figure 24.	Temperature sensor and RF EEPROM	40
Figure 25.	Linear sensor	41
Figure 26.	ST-LINK/V2 (SWD only)	42
Figure 27.	SWD	43
Figure 28.	Motor control	44
Figure 29.	Power	45
Figure 30.	2.4 inch LCD module	46
Figure 31.	Mechanical dimensions	50

1 Overview

1.1 Features

- Three 5 V power supply options: power jack, ST-LINK/V2 USB connector or daughterboard
- Audio speaker and microphone connected to DAC and ADC of STM32F051R8T6
- 2 Gbyte or more SPI interface MicroSD card
- I2C compatible serial interface temperature sensor
- RF E2PROM
- RS-232 and RS-485 communication
- IrDA transceiver
- IR LED and IR receiver
- SWD debug support, ST-LINK/V2 embedded
- 240 x 320 TFT color LCD connected to SPI interface of STM32F051R8T6
- Joystick with 4-direction control and selector
- Reset, tamper and user buttons
- 4 color LEDs
- Extension connector for daughterboard or wrapping board
- MCU voltage choice fixed at 3.3 V or adjustable from 2 to 3.6 V
- Linear sensor
- Light dependent resistor (LDR)
- Potentiometer
- Two HDMI connectors with DDC and CEC
- Motor control connector
- Boards RoHS compliant (lead free)

1.2 Demonstration software

Demonstration software is preloaded in the board's Flash memory for easy demonstration of the device peripherals in stand-alone mode. For more information and to download the latest version available, refer to the STM320518-EVAL demonstration software available at www.st.com.

1.3 Order code

To order the STM32F051R8T6 evaluation board, use the order code STM320518-EVAL.

1.4 Delivery recommendations

Some verifications are needed before using the board for the first time to make sure that nothing has been damaged during shipment and that no components are unplugged or lost.

When the board is extracted from its plastic bag, please check that no component remains in the bag.

The main components to verify are:

1. The 8 MHz crystal (X1) which may have been removed from its socket by a shock.
2. The MicroSD card which may have been ejected from the connector CN14 (left side of the board).
3. The dual interface EEPROM board (ANT7-M24LR-A) which may have been unplugged from the connector CN2 (top right corner of the board).

2 Hardware layout and configuration

The STM320518-EVAL evaluation board is designed around the STM32F051R8T6 (64-pin LQFP package). The hardware block diagram shown in *Figure 2* illustrates the connection between the STM32F051R8T6 and peripherals (motor control connector, RS-232, RS-485, audio DAC, linear sensor, microphone ADC, TFT LCD, IrDA, IR LED, IR receiver, LDR, MicroSD card, CEC and DDC on two HDMI connectors, RF E2PROM and temperature sensor and so on). *Figure 3* shows where you can locate these features on the evaluation board.

Figure 2. Hardware block diagram

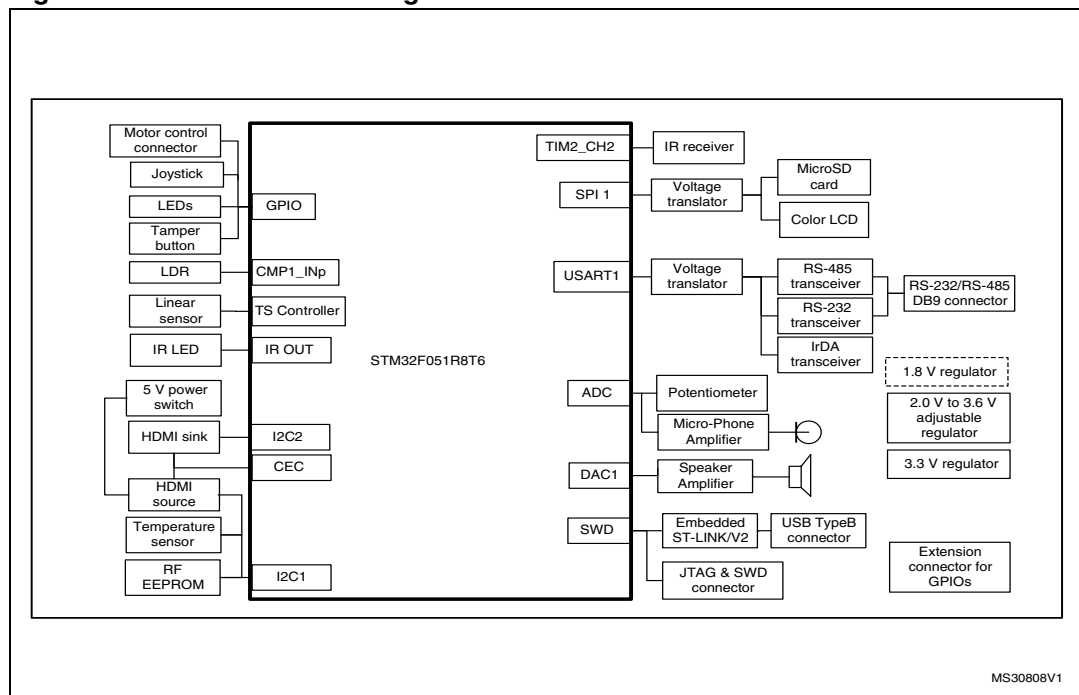
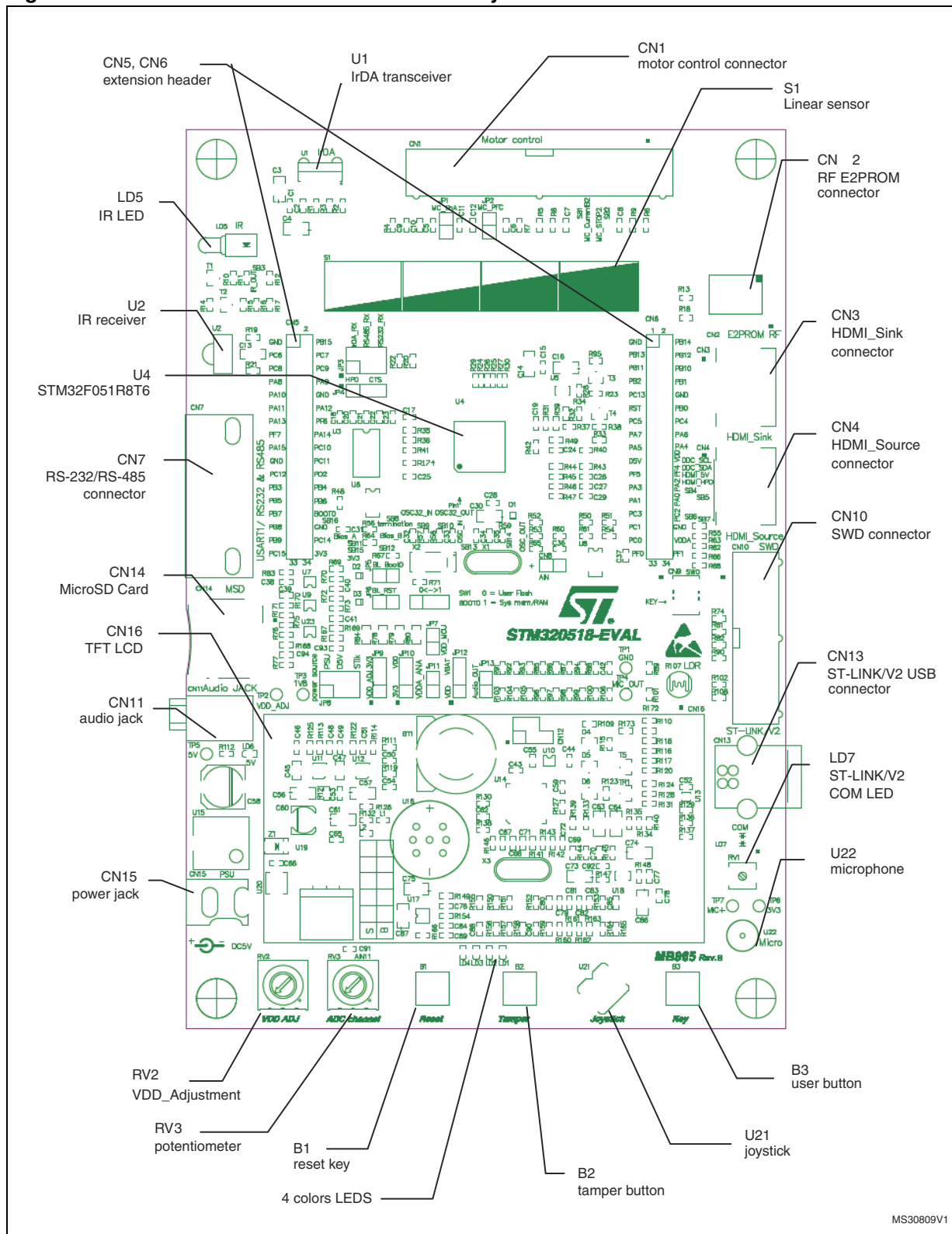

Figure 3. STM320518-EVAL evaluation board layout



2.1 Development and debug support

Version 2 of the ST-LINK (ST-LINK/V2) is embedded on the board. This tool allows onboard program loading and debugging of the STM32F051R8T6 using the SWD interface. The third-party debug tools are also supported by the SWD connector CN10.

A specific driver must be installed on your PC for communication with the embedded ST-LINK/V2. This driver, called *ST-LINK_V2_USBdriver.exe* is available on the web. To download and install this driver, refer to the software and development tools page for the STM32F0 family on www.st.com.

Third-party toolchains, such as Atollic TrueSTUDIO, Keil MDK-ARM, IAR EWARM and TASKING VX-toolset for ARM Cortex-M, support ST-LINK/V2 according to [Table 2](#).

Table 2. Third-party toolchain support

Manufacturer	Toolchain	From version...
Atollic	TrueSTUDIO	2.1
IAR	EWARM	6.20.4
Keil	MDK-ARM	4.20
TASKING	VX-toolset for ARM Cortex-M	4.0.1

The embedded ST-LINK/V2 is connected to the PC via a standard USB cable from connector CN13. The bicolor LED LD7 (COM) indicates the status of the communication as follows.

- Slow blinking Red/Off: at power-on before USB initialization.
- Fast blinking Red/Off: after the first correct communication between the PC and ST-Link/V2 (enumeration).
- Constant Red On: when initialization between the PC and ST-LINK/V2 is successfully finished.
- Constant Green On: after successful target communication initialization.
- Blinking Red/Green: during communication with the target.
- Red On: communication is finished and OK.
- Orange On: communication failure.

Note: The board can be powered via CN13 (embedded ST/LINK/V2 USB connector) even if an external tool is connected to CN9 (high density SWD connector) or CN10 (SWD connector).

2.2 Power supply

The STM320518-EVAL evaluation board is designed to be powered by a 5V DC power supply and to be protected by PolyZen from incorrect power plug-in events.

It is possible to configure the evaluation board to use any of the following three sources for the power supply.

- 5V DC power adapter connected to CN15, the power jack on the board (power supply unit (PSU) on the silk screen). External power supply is not provided with the board.
- 5V DC power with 500 mA limitation from CN13, the USB type B connector of ST-LINK/V2 (USB 5 V power source (STIk) on silkscreen).
- 5V DC power from CN6, the extension connector for daughterboard (daughterboard power source (D5V) on silkscreen).

The power source is selected by setting the related jumpers JP8 as described in [Table 3](#).

Table 3. Power source related jumpers





Jumper	Description
JP8	<p>JP8 selects one of the three possible power supply resources. For the power supply jack (CN15) to STM320518-EVAL only, JP8 is set as shown:</p> 
	<p>For power supply from the daughterboard connectors (CN6) to STM320518-EVAL only, JP8 is set as shown:</p> 
	<p>For power supply from USB (CN13) of ST-LINK/V2 to STM320518-EVAL only, JP8 is set as shown (default setting):</p> 
	<p>For power supply from the power supply jack (CN15) to both STM320518-EVAL and daughterboard connected on CN5 and CN6, JP8 is set as shown (the daughterboard must not have its own power supply connected):</p> 







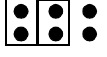

Table 3. Power source related jumpers (continued)

Jumper	Description
JP12	The Vbat pin of STM32F051R8T6 is connected to VDD when JP12 is set as shown (default setting): 
	The Vbat pin of STM32F051R8T6 is connected to a 3 V battery when JP12 is set as shown: 

A total of three power modes are supported on the board and can be configured by setting the related jumpers **JP7, JP9, JP10 and JP11** as described in [Table 4](#) and its related notes.

- Mode1: the VDD and VDDA are connected together and powered by a fixed 3.3 V.
- Mode2: the VDD and VDDA are connected together and powered by an adjustable voltage ranging from 2.0 V to 3.6 V.
- Mode3: the VDD is powered by an adjustable voltage ranging from 2.0 V to 3.6 V while VDDA is powered by a fixed 3.3 V.

Table 4. Power mode related jumpers

Power mode	Power mode configuration		MCU IDD measurement
	JP9	JP10	
Mode1			OK
			Not allowed
Mode2			OK
Mode3			Not allowed

Note: MCU IDD measurement can be done with a current meter mounted on JP7 when it is open.

Note: Jumper JP11 must be open (to disconnect VDDA from all analog power VDD_ANA which is connected to the analog circuits on the board) for MCU Idd measurement.

The LED LD6 is lit when the STM320518-EVAL evaluation board is correctly powered by 5 V.

2.3 Clock source

Two clock sources are available on the STM320518-EVAL evaluation board for STM32F051R8T6 and RTC embedded.

- X1, 8 MHz crystal with a socket for the STM32F051R8T6 microcontroller. It can be removed from the socket when the internal RC clock is used.
- X2, 32 kHz crystal for embedded RTC.

Table 5. 8 MHz crystal X1 related solder bridges

Jumper	Description
SB13	PF0 is connected to an 8 MHz crystal when SB13 is open (default setting).
	PF0 is connected to an extension connector CN6 when SB13 is closed. In such a case, C34 and X1 must be removed.
SB14	PF1 is connected to an 8 MHz crystal when SB14 is open (default setting).
	PF1 is connected to an extension connector CN6 when SB14 is closed. In such a case, R59 must be removed to avoid disturbance due to the 8 MHz quartz.

Table 6. 32 kHz crystal X2 related solder bridges

Jumper	Description
SB9	PC14 is connected to a 32 kHz crystal when SB9 is open (default setting).
	PC14 is connected to an extension connector CN5 when SB9 is closed. In such a case, R57 must be removed to avoid disturbance due to the 32 kHz quartz.
SB10	PC15 is connected to a 32 kHz crystal when SB10 is open (default setting).
	PC15 is connected to an extension connector CN5 when SB10 is closed. In such a case, R58 must be removed to avoid disturbance due to the 32 kHz quartz.

2.4 Reset source

The reset signal of the STM320518-EVAL evaluation board is low active and the reset sources include the following.

- Reset button B1
- Debugging tools from SWD connector CN10 and CN9
- Daughterboard from CN6
- Embedded ST-LINK/V2
- RS232 connector CN7 for ISP.

Note: The jumper JP6 is to be closed for RESET handled by pin8 of the RS-232 connector CN7 (CTS signal). Refer to [Section 2.7](#) information.

2.5 Boot option

The STM320518-EVAL evaluation board can boot from:

- Embedded User Flash
- System memory with boot loader for ISP
- Embedded SRAM for debugging

The boot option is configured by setting switch SW1 (BOOT0) and one Option bit in the Small Information block (SIF). The BOOT0 can also be configured via the RS-232 connector CN7.

Table 7. Boot related switch



Switch configuration	Bit12 in USER OPTION BYTES	Boot source
0 <-> 1 	X	STM320518-EVAL boot from User Flash when SW1 and Bit12 in User OPTION bytes set as shown to the left (default setting).
0 <-> 1 	0	STM320518-EVAL boot from Embedded SRAM when SW1 and Bit12 in User OPTION bytes set as shown to the left.
0 <-> 1 	1	STM320518-EVAL boot from System Memory when SW1 and Bit12 in User OPTION bytes set as shown to the left.

Table 8. Boot0 related jumpers

Jumper	Description
JP5	The Bootloader_BOOT0 is managed by pin 6 of connector CN7 (RS-232 DSR signal) when JP5 is closed. This configuration is used for the boot loader application only. Default Setting: Not fitted

2.6 Audio

The STM320518-EVAL evaluation board supports a speaker that is connected to the DAC output of the STM32F051R8T6 through an audio amplifier and microphone, which is in turn connected to the ADC input of the STM32F051R8T6 through a microphone amplifier. The speaker can be enabled or disabled by setting JP13 ([Table 9](#)).





Table 9. Audio related jumpers

Jumper	Description
JP13	Speaker amplifier U17 is enabled when JP13 is open (default setting).
	Speaker amplifier U17 is disabled when JP13 is closed.

2.7 RS-232, RS-485 and IrDA

The RS-232 (with hardware flow control CTS and RTS), RS-485 and IrDA communication is supported by D-type 9-pin RS-232/RS-485 connectors CN7, and IrDA transceiver U1 which is connected to USART1 of the STM32F051R8T6 on the STM320518-EVAL evaluation board. The signal Bootloader_RESET (shared with the CTS signal) and Bootloader_BOOT0 (shared with the DSR signal) are added to the RS-232 connector CN7 for ISP support.

Table 10. RS-232 and IrDA related jumpers

Jumper	Description
JP3	RS232_RX is connected to the RS-232 transceiver and RS-232 communication is enabled when JP3 is set as shown (default setting): <div style="text-align: right; margin-top: 10px;"> RS232_RX RS485_RX IrDA_RX  </div>
	RS485_RX is connected to the RS-485 transceiver and RS-485 communication is enabled when JP3 is set as shown: <div style="text-align: right; margin-top: 10px;"> RS232_RX RS485_RX IrDA_RX  </div>
	IrDA_RX is connected to the IrDA transceiver and IrDA communication is enabled when JP3 is set as shown: <div style="text-align: right; margin-top: 10px;"> RS232_RX RS485_RX IrDA_RX  </div>
JP4	PA11 is connected to the RS-232 transceiver as RS232_CTS when JP4 is set as shown (default setting): <div style="text-align: right; margin-top: 10px;"> 1 2 3  </div>
	PA11 is connected to the HDMI_Sink connector as HPD when JP4 is set as shown: <div style="text-align: right; margin-top: 10px;"> 1 2 3  </div>

The RS-485 communication is supported by the RS-485 transceiver ST485ABDR, which is connected to pin4 and pin9 of the D-type 9-pin connectors CN7 (that share the same connector as USART1).

Table 11. RS-485 related solder bridges

Jumper	Description
SB11,SB12	The external failsafe biasing are enabled when solder bridges SB11 and SB12 are closed. Default setting: not fitted
SB8	The bus termination is enabled when solder bridge SB8 is closed. Default setting: not fitted
SB16	The AC termination is disabled when solder bridge SB16 is closed for high baud rate communication. Default setting: not fitted

2.8 Linear sensor

The linear sensor is supported on the STM320518-EVAL evaluation board and connected to four capacitive sensing channels (PB[11:14]) in group6 with an active shield connected to two capacitive sensing channels (PC5 and PB0) in group3.

Note: The linear sensor is only fully functional when the STM320518-EVAL is powered on power mode 1 (both VDD and VDDA are connected to a fixed 3.3 V). It is potentially necessary to adjust the capacitor value of C14 and C15 and the firmware to adapt them to the voltage range from 2 V to 3.6 V of VDD on power modes 2 and 3.

2.9 MicroSD card

The 2 GB (or more) MicroSD card connected to the SPI1 port of the STM32F051R8T6 is available on the board. MicroSD card detection is managed by the standard IO port PB15.

2.10 Analog input

The two-pin header CN8 and 10 kohm potentiometer RV3 are connected to PC1 of the STM32F051R8T6 as an analog input. A low-pass filter can be implemented by replacing R60 and C36 with the correct resistor and capacitor values as required by the end-user application.

2.11 LDR (light dependent resistor)

The VDDA is divided by the resistor bridge of the LDR VT9ON1 and 8.2 K resistor. It is connected to PA1 (COM1_IN+/ADC IN1) as shown in [Figure 4](#).

Figure 4. STM320518-EVAL evaluation board

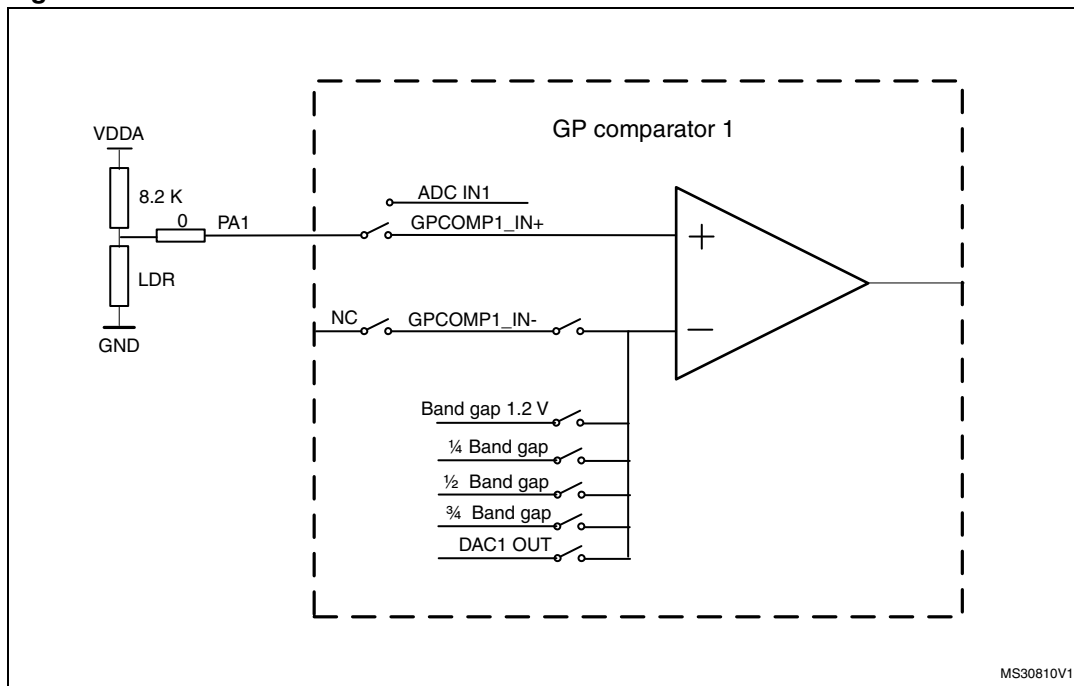

It is possible to compare the LDR output with 1/4 band gap, 1/2 band gap, 3/4 band gap, band gap and DAC1 OUT, and to connect the LDR output to ADC IN1 for AD conversion.

2.12 Temperature sensor

A temperature sensor STLM75M2E is connected to the I2C1 bus of the STM32F051R8T6. It shares the same I2C1 bus as the RF E2PROM and DDC on the HDMI_Source connector CN4.

2.13 Display and input devices

The 2.4 inch color TFT LCD connected to the SPI1 port of the STM32F051R8T6 and four general-purpose color LEDs (LD 1, 2, 3 and 4) are available as display devices. The 4-direction joystick (U21) with selection key connected to PA0 and support wakeup feature and tamper button (B2) are available as input devices.

Table 12. LCD modules

2.4-inch TFT LCD connector CN16					
Pin	Description	Pin connection	Pin	Description	Pin connection
1	CS	PF4	9	VDD	3.3 V
2	SCL	PA5	10	VCI	3.3 V
3	SDI	PA7	11	GND	GND
4	RS	-	12	GND	GND
5	WR	-	13	BL_VDD	5 V

Table 12. LCD modules (continued)

2.4-inch TFT LCD connector CN16					
Pin	Description	Pin connection	Pin	Description	Pin connection
6	RD	-	14	BL_Control	5 V
7	SDO	PB4	15	BL_GND	GND
8	RESET	RESET#	16	BL_GND	GND

Note: The bi-directional voltage translator is implemented on the SPI MOSI signal between the STM32F051R8T6 and the LCD to support the 3-wire serial interface of the AM240320LGTNqw-01H LCD panel. The direction of this voltage translator is controlled by IO PB2 (the IO PA7 acts as MOSI when PB2 is high or as MISO when PB2 is LOW).

2.14 RF E2PROM

An RF E2PROM module ANT7-M24LR-A is mounted on connector CN2 and is connected to the I2C1 bus of the STM32F051R8T6. It shares the same I2C1 bus as the temperature sensor U8 and DDC on the HDMI_Source connector CN4.

2.15 HDMI CEC

Two HDMI connectors CN3 and CN4 are available on the STM320518EVAL board.

- Connector CN3 is an HDMI sink connector with:
 - DDC connected to I2C2 of the STM32F051R8T6
 - HPD controlled by I/O PA11 through transistor T3
 - CEC connected to PB10 through transistor T4
- Connector CN4 is an HDMI source connector with:
 - DDC connected to I2C1 of the STM32F051R8T6 and shared with the temperature sensor and RF E2PROM
 - HPD controlled by I/O PA8
 - CEC connected to PB10 through transistor T4
 - 5V HDMI powered by power switch U5

Signals TDMS D+[0,1,2], TDMS_CLK+, TDMS D-[0,1,2] and TDMS_CLK are connected together on these two HDMI connectors.

CEC injector mode can be enabled by reworking the PCB (for debugging purposes only):

- Remove resistors R63, R66, R23, R62, R68, R51 and R13.
- Close solder bridges SB4, SB5, SB6 and SB7.

Note: The I/O PA11 must be set in open-drain output mode by firmware for HPD signal control on the HDMI sink connector CN3.

2.16 IR LED and IR receiver

The IR receiver TSOP34836 is connected to PB3 of the STM32F051R8T6 and a current around 100 mA on the IR LED is driven by PB9 through transistors T1 and T2 on the board.

Note: The IR LED may be driven by PB9 directly with a 20 mA current when SB3 is closed and R11 is removed.

2.17 Motor control

The STM320518-EVAL evaluation board supports both asynchronous and synchronous three-phase brushless motor control via a 34-pin connector CN1. This connector provides all required control and feedback signals to and from the motor power-driving board. Available signals on this connector include emergency stop, motor speed, 3-phase motor current, bus voltage, heatsink temperature coming from the motor driving board and six channels of the PWM control signal going to the motor driving circuit.

Some PCB reworks are required for the motor control application to disconnect peripherals that share IOs with the motor control connector. These IOs need to be connected to the motor control connector.

- Remove resistors R89, R52, R19, R55, R32, R38, R42, R88, R83, R20, R36, R18 and R50.
- Mount R25, R29, R30, R39, R4, R35, R37, R44, R22 and R41 with a 0 ohm resistor.

All resistors to be removed are marked in red while resistors to be soldered are marked in green in [Figure 5](#).

Figure 5. STM320518-EVAL evaluation board motor control PCB reworks

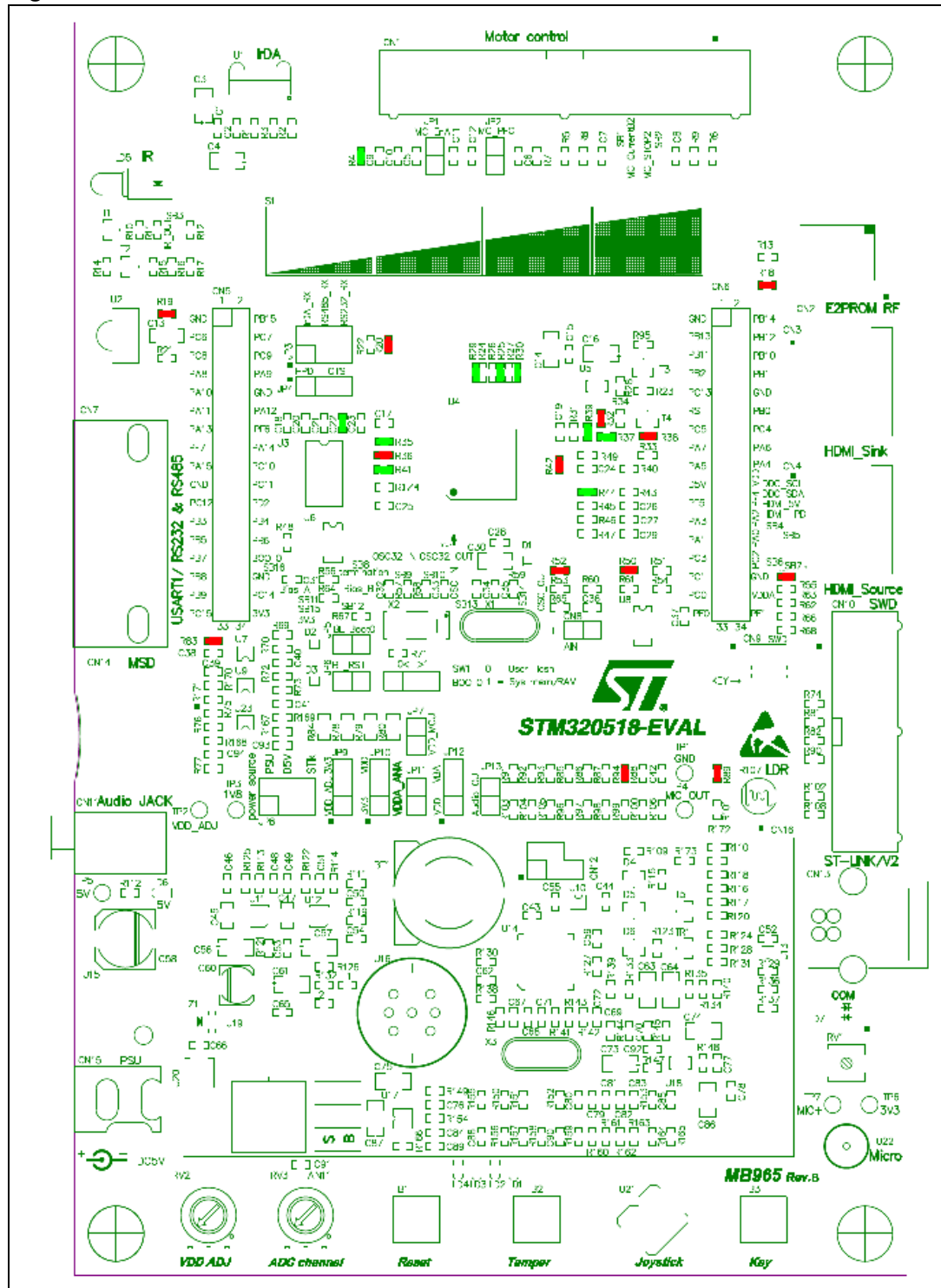

The RS-232 connector CN7 is re-connected to USART1 on the IOs PB6 and PB7 instead of PA9 and PA10 for the motor control application.

Table 13. Motor control related jumpers

Jumper	Description
JP2	<p>The special motor current sampling operation is enabled when JP2 is fitted (PB0 connected to PA12). The IO pins PB0 and PA12 are disconnected and can be used by the daughterboard when JP2 is not fitted.</p> <p>Default setting: not fitted</p>
JP1	<p>JP1 should be kept open when the encoder signal is from pin31 of the motor control connector CN1, while it should be kept closed when the analog signal is from pin31 of CN1 for special motors.</p> <p>Default setting: not fitted</p>
SB1	<p>Pin17 of the motor connector CN1 is connected to PA3 as MC_currentB2 when SB1 is closed.</p> <p>Default setting: open</p>
SB2	<p>Pin1 of the motor connector CN1 is connected to PA3 as MC_EmergencySTOP2 when SB2 is closed.</p> <p>Default setting: open</p>

Note: The solder bridges SB1 and SB2 cannot be closed at the same time.

3 Connector

3.1 Motor control connector CN1

Figure 6. Motor control connector CN1

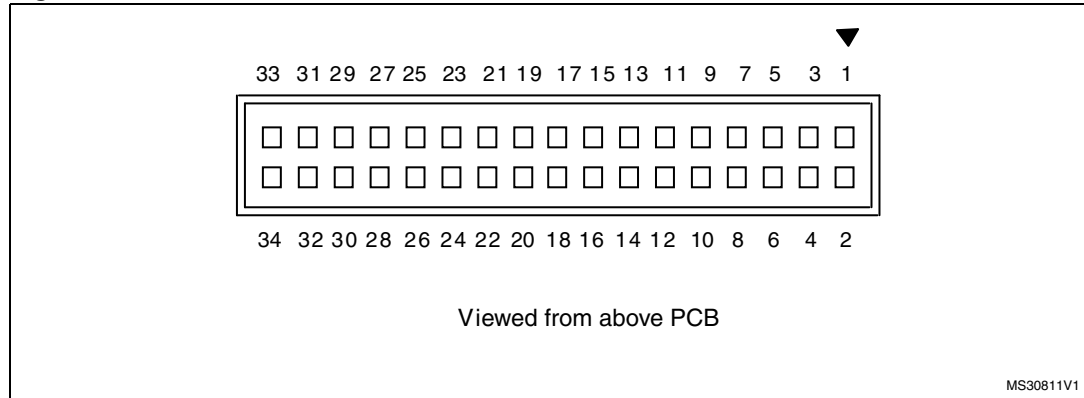

Table 14. Motor control connector CN1

Description	Pin of STM32F051R8T6	Pin no. of CN1	Pin no. of CN1	Pin of STM32F051R8T6	Description
Emergency STOP	PB12	1	2		GND
Emergency STOP2	PA3				
PWM-UH	PA8	3	4		GND
PWM-UL	PB13	5	6		GND
PWM-VH	PA9	7	8		GND
PWM-VL	PB14	9	10		GND
PWM-WH	PA10	11	12		GND
PWM-WL	PB15	13	14	PA1	Bus voltage
PHASE A CURRENT	PA2	15	16		GND
PHASE B CURRENT	PC5	17	18		GND
PHASE B CURRENT2	PA3				
PHASE C CURRENT	PC4	19	20		GND
NTC BYPASS RELAY	PA6	21	22		GND
DISSIPATIVE BRAKE PWM	PB11	23	24		GND
+5 V power		25	26	PC2	Heatsink temperature
PFC SYNC	PB0/PA12	27	28		3.3 V power (VDD MCU)
PFC PWM	PB1	29	30		GND
Encoder A	PA15	31	32		GND
MC_BEMF_A	PC0				

Table 14. Motor control connector CN1

Description	Pin of STM32F051R8T6	Pin no. of CN1	Pin no. of CN1	Pin of STM32F051R8T6	Description
Encoder B	PB3	33	34	PB10	Encoder index
MC_BEMF_B	PC1			PC3	MC_BEMF_C

3.2 RF E2PROM connector CN2

Figure 7. RF EEPROM daughterboard connector CN2

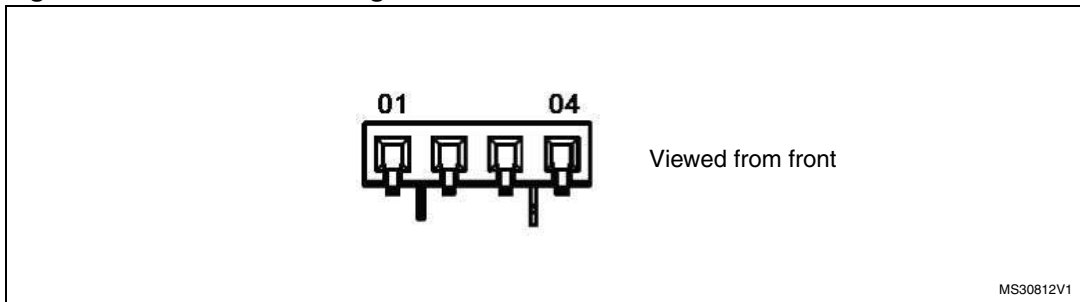

Table 15. RF E2PROM connector CN2

Pin number	Description	Pin number	Description
1	SDA (PB7)	3	+5 V
2	SCL (PB6)	4	GND

3.3 HDMI sink connector CN3

Figure 8. HDMI sink connector CN3

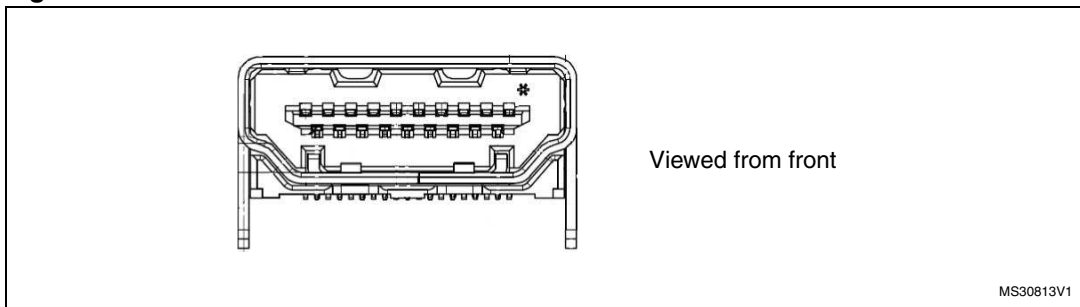
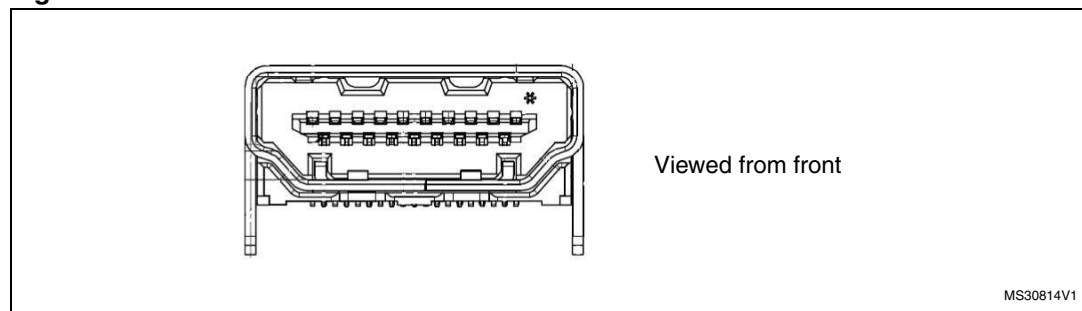

Table 16. HDMI sink connector CN3

Pin number	Description	Pin number	Description
1,3,4,6,7,9,10,12	TMDS differential signal pair connected to CN4	16	SDA (PF7)
13	CEC (PB10)	2,5,8,11,17	GND
14	NC	18	HDMI_5V_Sink
15	SCL (PF6)	19	HPD (PA11 through transistor)

3.4 HDMI source connector CN4

Figure 9. HDMI source connector CN4**Table 17. HDMI source connector CN4**

Pin number	Description	Pin number	Description
1,3,4,6,7,9,10,12	TMDS differential signal pair connected to CN3	16	SDA (PB7)
13	CEC (PB10)	2,5,8,11,17	GND
14	NC	18	HDMI_5V_Source from power switch U5
15	SCL (PB6)	19	HPD (PA8)

3.5 Daughterboard extension connector CN5 and CN6

Two 34-pin male headers CN5 and CN6 can be used to connect with the daughterboard or standard wrapping board to the STM320518-EVAL evaluation board. All GPIOs are available on it. The space between these two connectors and the position of the power, GND and RESET pins is defined as a standard that allows to develop common daughterboards for several evaluation boards.

The standard width between CN5 pin1 and CN6 pin1 is 2700 mils (68.58 mm). This standard has been implemented on the majority of evaluation boards.

Each pin on CN5 and CN6 can be used by a daughterboard after disconnecting it from the corresponding function block on the STM320518-EVAL evaluation board. Details are provided in [Table 18](#) and [Table 19](#).

Table 18. Daughterboard extension connector CN5

Pin	Description	Alternative function	How to disconnect from the function block on STM320518-EVAL board
1	GND	-	-
3	PC6	JOY_Up	Remove R87
5	PC8	JOY_Right	Remove R98
7	PA8	HDMI_HPD_Source / MC_TIM1_CH1 (UH)	Remove R55 Disconnect MC power board from CN1
9	PA10	USART_RX/ MC_TIM1_CH3 (WH)	Keep JP3 open Disconnect MC power board from CN1
11	PA11	USART_CTS/HDMI_HPD_Sink	Keep JP4 open
13	PA13	SWDAT	-
15	PF7	I2C2_SDA_HDMI_Sink	-
17	PA15	MC_TIM2_CH1 (Encoder A)	Disconnect MC power board from CN1
19	GND	-	-
21	PC12	LED3	Remove R92
23	PB3	IR_IN/ MC_TIM2_CH2 (encoder B)	Remove R19 Disconnect MC power board from CN1
25	PB5	TempSensor_INT	Remove R61
27	PB7	TempSensor/HDMI/RF_SDA / MC_USART1_RX	Remove R50
29	PB8	User_KEY	Remove R99
31	PB9	IR_OUT	Remove R17
33	PC15	OSC32_OUT	Close SB10 Remove R58
2	PB15	SD_Detection	Remove R83
4	PC7	JOY_DOWN	Remove R86
6	PC9	JOY_LEFT	Remove R85
8	PA9	RS232/RS485 / irDA_TX/MC TIM1_CH2 (VH)	Disconnect MC power board from CN1
10	GND	-	-
12	PA12	RS485_DIR / RS232_RTS/ MC_IO (PFC_sync1)	-
14	PF6	I2C2_SCL_HDMI_Sink	-
16	PA14	SWCLK	-
18	PC10	LED1	Remove R93
20	PC11	LED2	Remove R105
22	PD2	LED4	Remove R104
24	PB4	LCD/SD_MISO	Remove R174

Table 18. Daughterboard extension connector CN5 (continued)

Pin	Description	Alternative function	How to disconnect from the function block on STM320518-EVAL board
26	PB6	TempSensor / HDMI/RF_SCL / MC_USART1_TX	Remove R18
28	BOOT0	BOOT0	Keep JP5 open
30	GND	-	-
32	PC14	OSC32_IN	Remove R57 Close SB9
34	+3V3	+3V3	Close SB15

Table 19. Daughterboard extension connector CN6

Pin	Description	Alternative function	How to disconnect from the function block on STM320518-EVAL board
1	GND	-	-
3	PB13	TS_CH2/ MC_TIM1_CH1N(UL)	-
5	PB11	TS_CAP/ MC_IO (dissipative brake)	Remove R31
7	PB2	1.8 V POR	-
9	PC13	TAMPER_KEY	Remove R96
11	RESET#	-	-
13	PC5	TS_Shield / MC_AIN15(Current B)	Mount a 0 ohm resistor on R33
15	PA7	LCD/SD_MOSI	-
17	PA5	LCD/SD_SCK	-
19	D5V	-	-
21	PF5	SD_CS	Remove R75
23	PA3	MC_AIN3_COMP2_IN+ (Current B2) / (EmergencySTOP2)	Disconnect MC power board from CN1
25	PA1	LDR_IN+ / MC_AIN1_COMP1_INI+ (bus voltage)	Remove R89 Disconnect MC power board from CN1
27	PC3	MC_Ain13 (BEMF_C)	-
29	PC1	Potentiometer / MC_AIN11 (BEMF_B)	Remove R52
31	PC0	Audio_IN / MC_AIN10 (BEMF_A)	Remove R88
33	PF0	OSC_IN	Close SB13 Remove C34 and X1
2	PB14	TS_CH3/ MC_TIM1_CH2N (VL)	Disconnect MC power board from CN1
4	PB12	TS_CH1/ MC_TIM1_BKIN (emergency STOP)	Remove R9
6	PB10	HDMI_CEC/ MC_TIM2_CH3 (encoder index)	Remove R32 Disconnect MC power board from CN1

Table 19. Daughterboard extension connector CN6 (continued)

Pin	Description	Alternative function	How to disconnect from the function block on STM320518-EVAL board
8	PB1	MC_TIM3_CH4 (PFC PWM)	Disconnect MC power board from CN1
10	GND	-	-
12	PB0	TS_Shield_CAP/ MC_TIM3_CH3 (PFC_sync2)	Mount a 0 ohm resistor on R49
14	PC4	MC_AIN14 (current C)	Disconnect MC power board from CN1
16	PA6	MC_IO (NTC_bypass)	Disconnect MC power board from CN1
18	PA4	Audio_OUT	Remove R103
20	VDD	-	-
22	PF4	LCD_CS	Remove R94
24	PA2	MC_ADC_IN2 (Current A)	Disconnect MC power board from CN1
26	PA0	JOY_SEL	Remove R97
28	PC2	MC_ADC_IN12 (heatsink temperature)	Disconnect MC power board from CN1
30	GND	-	-
32	VDDA	-	-
34	PF1	OSC_OUT	Remove R59 Close SB14

3.6 RS-232 and RS-485 connector CN7

Figure 10. RS-232 and RS-485 connector

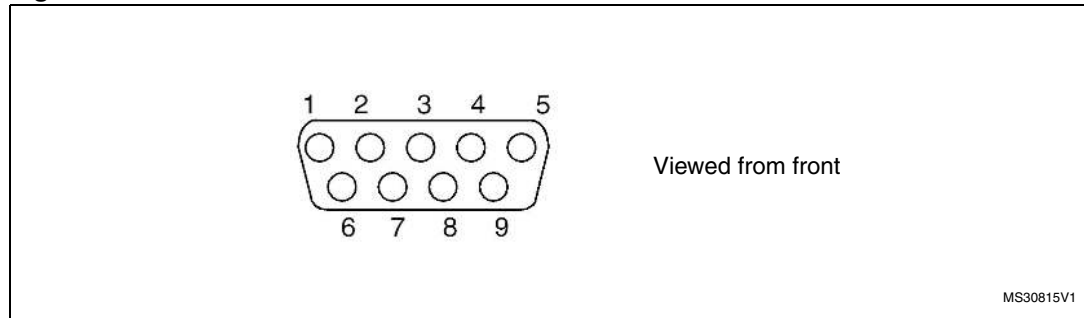

Table 20. RS-232 and RS-485 connector CN7

Pin number	Description	Pin number	Description
1		6	Bootloader_BOOT0
2	RS232_RX (PA10)	7	RS232_RTS(PA12)
3	RS232_TX (PA9)	8	RS232_CTS(PA11) / Bootloader_RESET
4	RS485_A	9	RS485_B
5	GND		

3.7 Analog input connector CN8

Figure 11. Analog input-output connector CN8

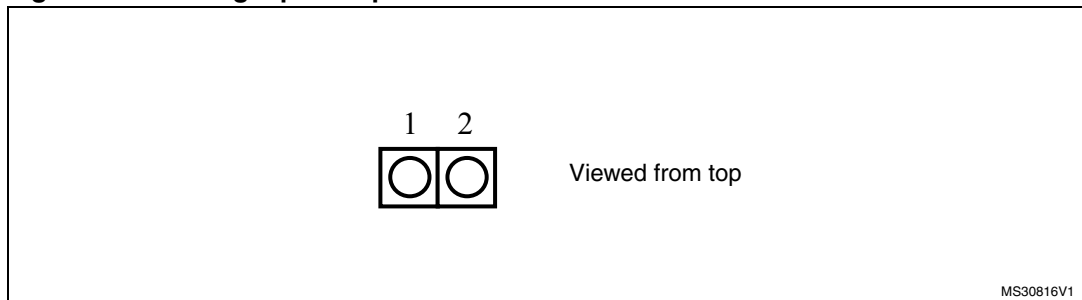

Table 21. Analog input-output connector CN8

Pin number	Description	Pin number	Description
1	Analog input-output PC1	2	GND

3.8 High density SWD connector CN9

Figure 12. High density SWD debugging connector CN9

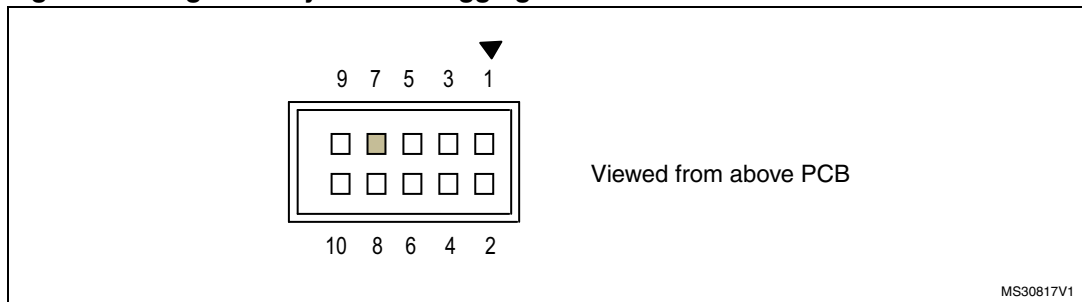

Table 22. High density SWD debugging connector CN9

Pin number	Description	Pin number	Description
1	VDD	2	SWDAT
3	GND	4	SWCLK
5	GND	6	-
7	KEY	8	-
9	GND	10	RESET#

3.9 Standard SWD connector CN10

Figure 13. Standard SWD debugging connector CN10

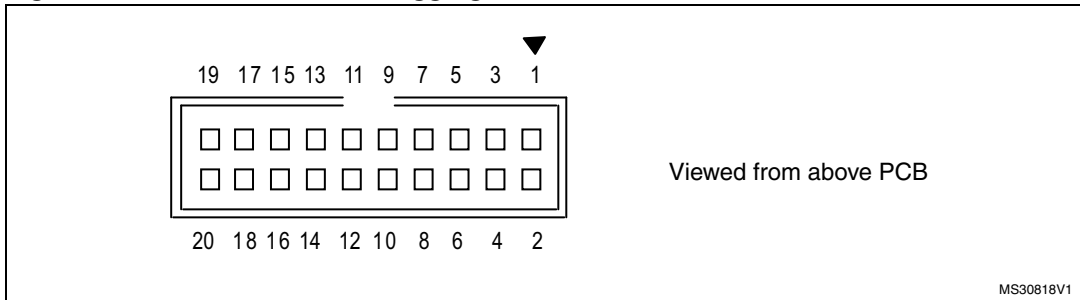

Table 23. Standard SWD debugging connector CN10

Pin number	Description	Pin number	Description
1	VDD	2	VDD
3	-	4	GND
5	-	6	GND
7	SWDAT	8	GND
9	SWCLK	10	GND
11	10 K pull-down	12	GND
13	-	14	GND
15	RESET#	16	GND
17	10 K pull-down	18	GND
19	10 K pull-down	20	GND

3.10 Audio jack CN11

A 3.5 mm stereo audio jack CN11 connected to the audio DAC is available on the STM320518-EVAL board.

3.11 ST-LINK/V2 programming connector CN12

The connector CN12 is used only for embedded ST-LINK/V2 programming during board manufacture. It is not populated by default and is not intended for the end user.

3.12 ST-LINK/V2 USB type B connector CN13

The USB connector CN13 is used to connect the embedded ST-LINK/V2 to a PC for debugging purposes.

Figure 14. USB type B connector CN13

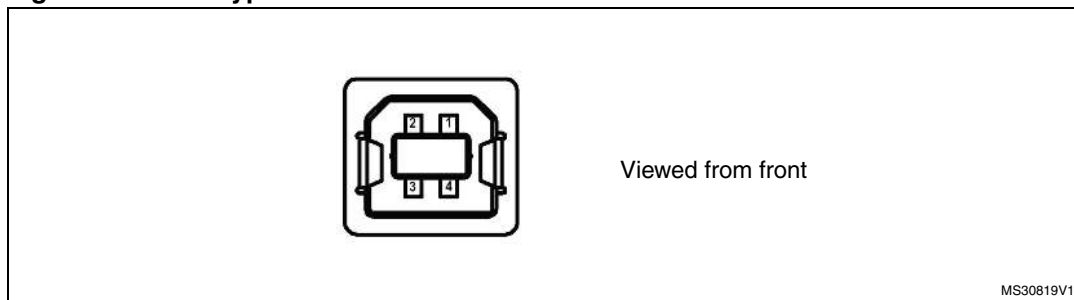

Table 24. USB type B connector CN13

Pin number	Description	Pin number	Description
1	VBUS (power)	4	GND
2	DM	5,6	Shield
3	DP		

3.13 MicroSD connector CN14

Figure 15. MicroSD connector CN14

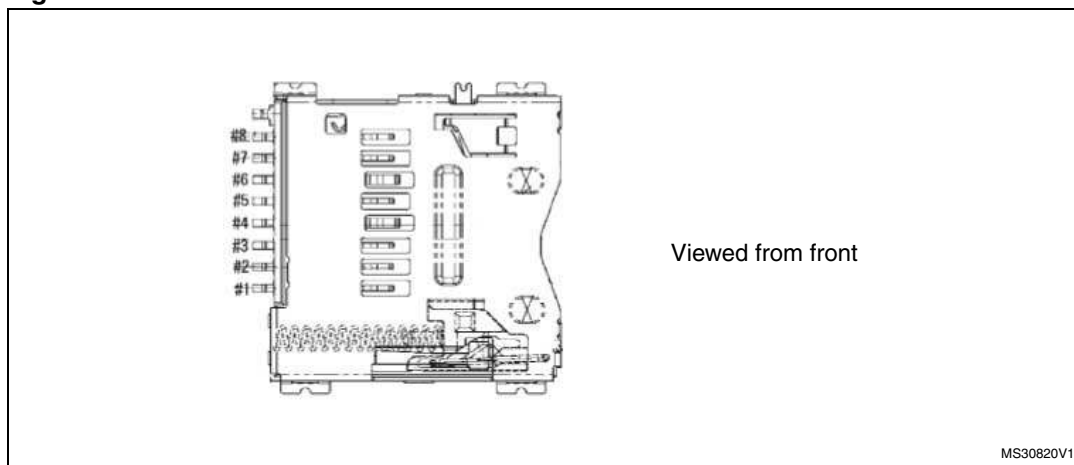

Table 25. MicroSD connector CN14

Pin number	Description	Pin number	Description
1		5	MicroSDcard_CLK (PA5)
2	MicroSDcard_CS (PF5)	6	Vss/GND
3	MicroSDcard_DIN (PA7)	7	MicroSDcard_DOUT (PB4)
4	+3.3 V	8	
		10	MicroSDcard_detect (PB15)

3.14 Power connector CN15

The STM320518-EVAL evaluation board can be powered from a 5 V DC power supply via the external power supply jack (CN15) shown in [Figure 16](#). The central pin of CN15 must be positive.

Figure 16. Power supply connector CN15

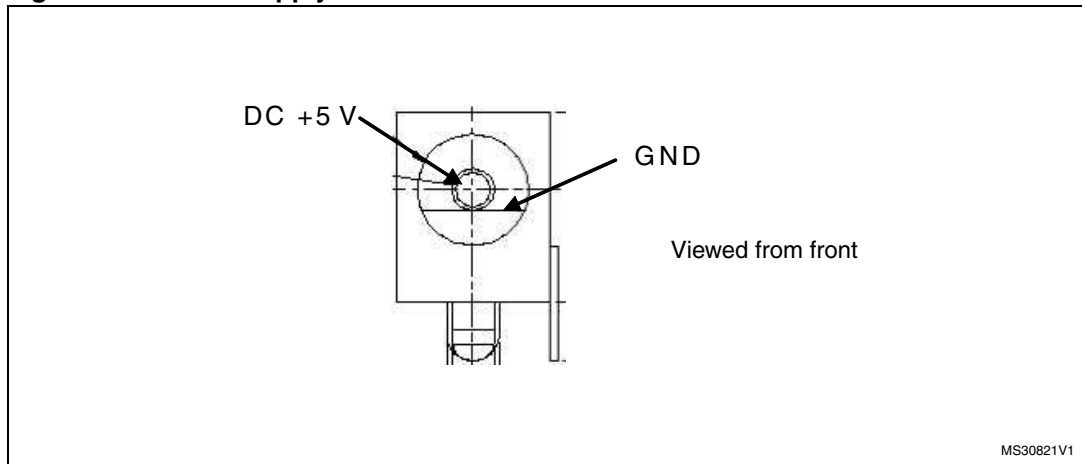

4 Board schematics

The following schematic diagrams are listed.

- [Figure 17: STM320518-EVAL on page 33](#)
- [Figure 18: MCU on page 34](#)
- [Figure 19: Audio on page 35](#)
- [Figure 20: HDMI_CEC on page 36](#)
- [Figure 21: LCD and micro SD card on page 37](#)
- [Figure 22: Peripherals on page 38](#)
- [Figure 23: RS-232, RS-485 and IrDA on page 39](#)
- [Figure 24: Temperature sensor and RF EEPROM on page 40](#)
- [Figure 25: Linear sensor on page 41](#)
- [Figure 26: ST-LINK/V2 \(SWD only\) on page 42](#)
- [Figure 27: SWD on page 43](#)
- [Figure 28: Motor control on page 44](#)
- [Figure 29: Power on page 45](#)
- [Figure 30: 2.4 inch LCD module on page 46](#)

Figure 17. STM320518-EVAL

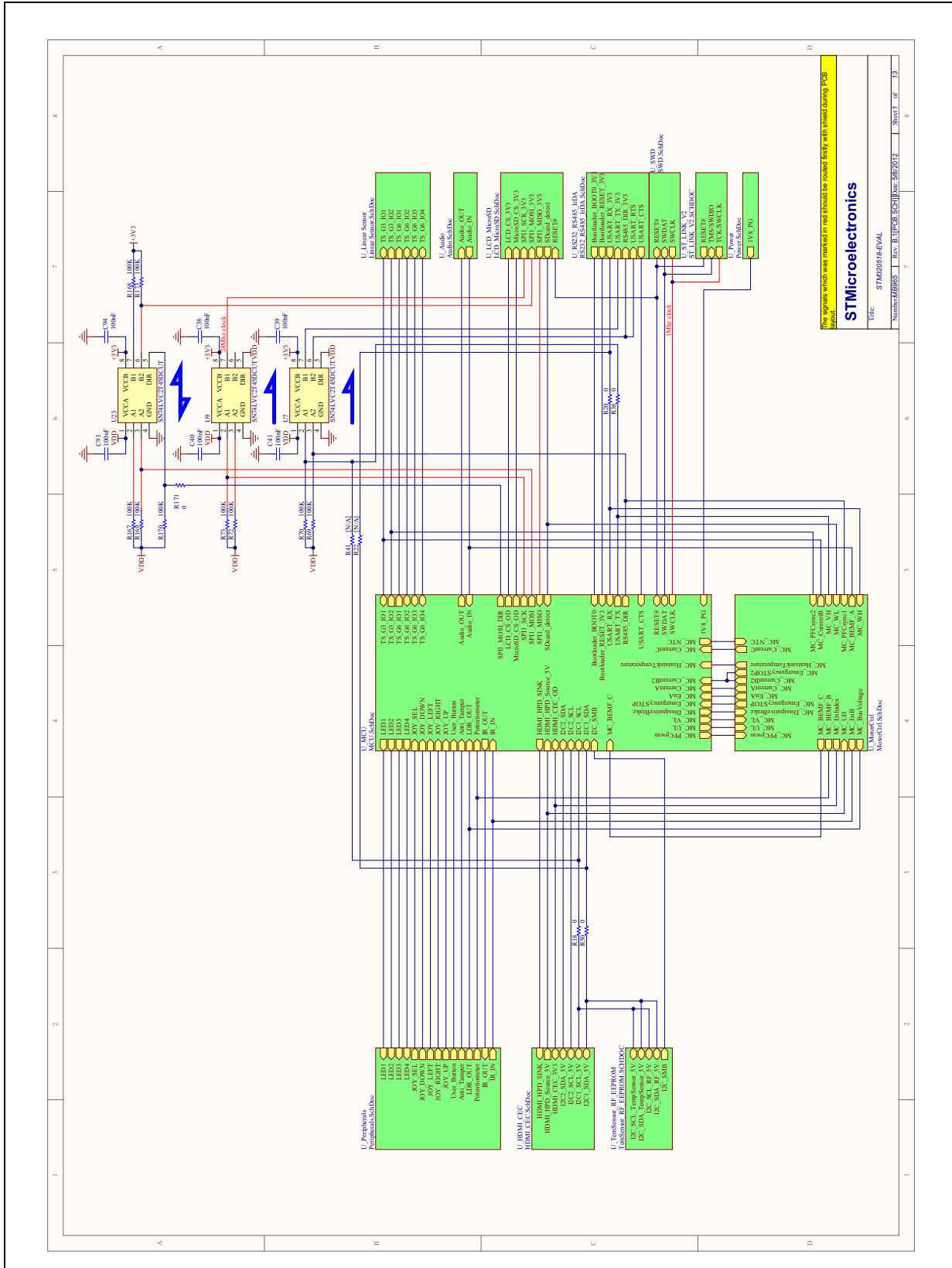

Figure 18. MCU

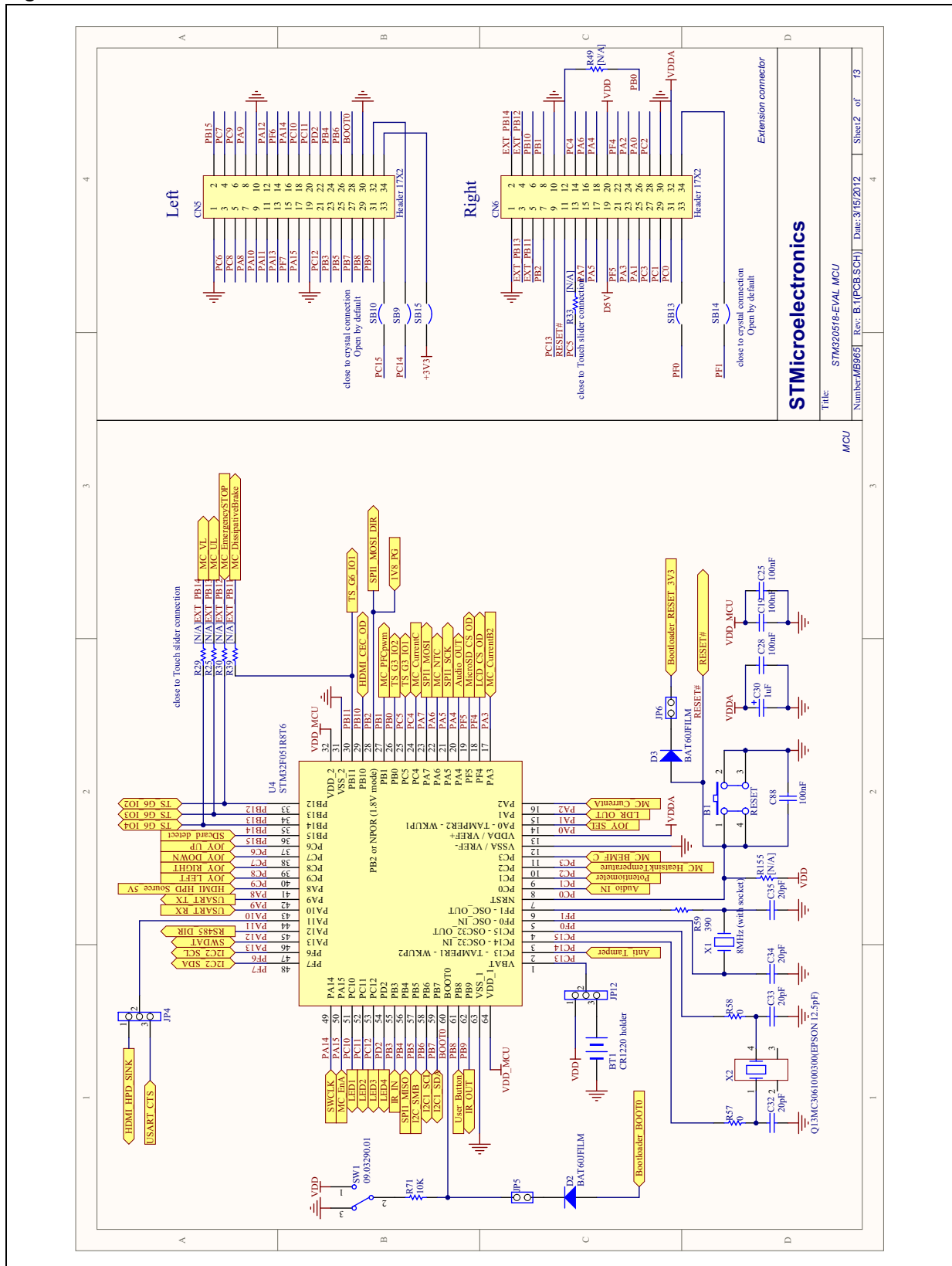
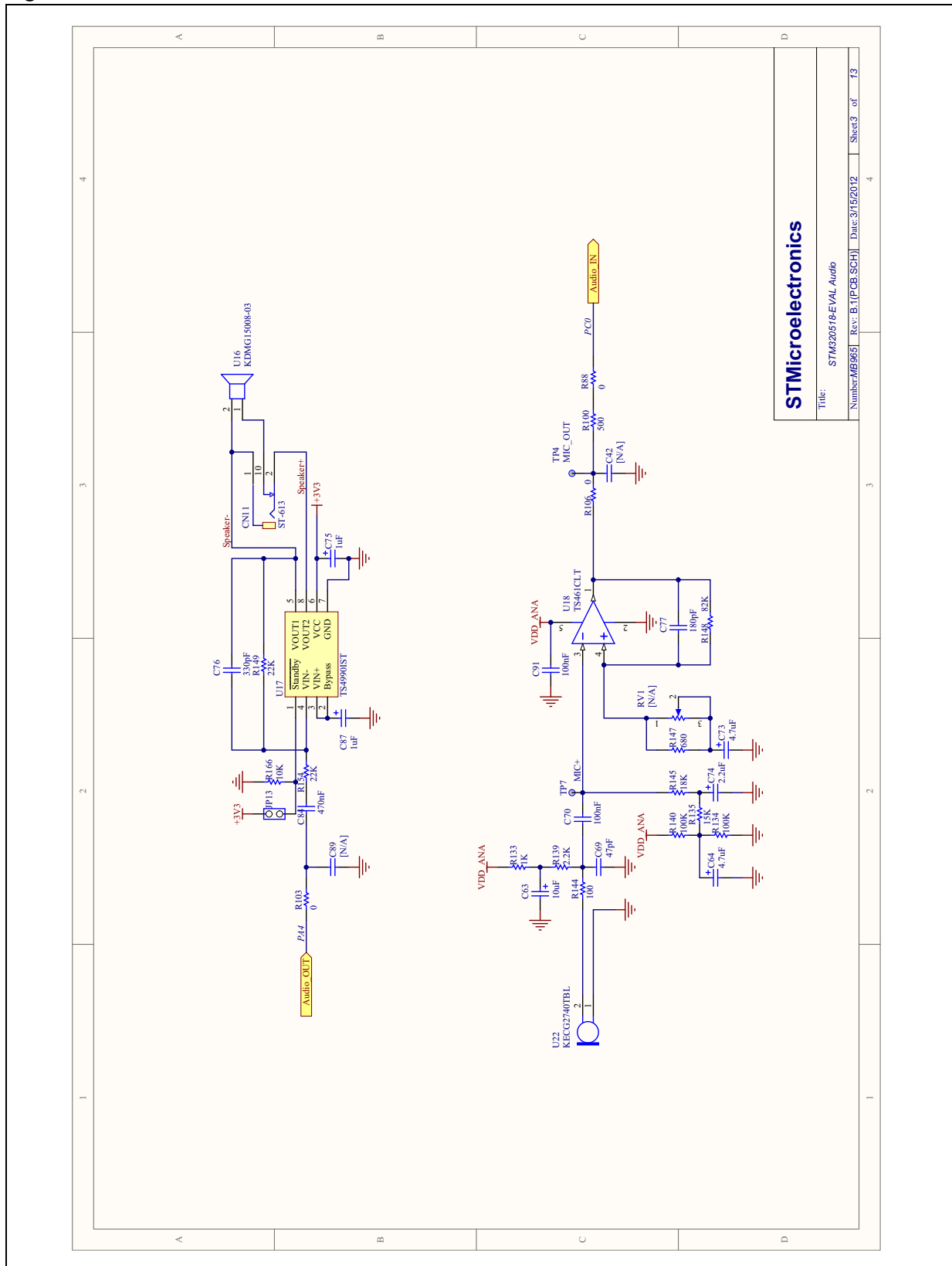

Figure 19. Audio



STMicroelectronics
 Title: STM320518-EVAL-Audio
 Number/MB965 Rev: B.1(PCB:SCH) Date: 9/15/2012 Sheet 3 of 13

Figure 20. HDMI_CEC

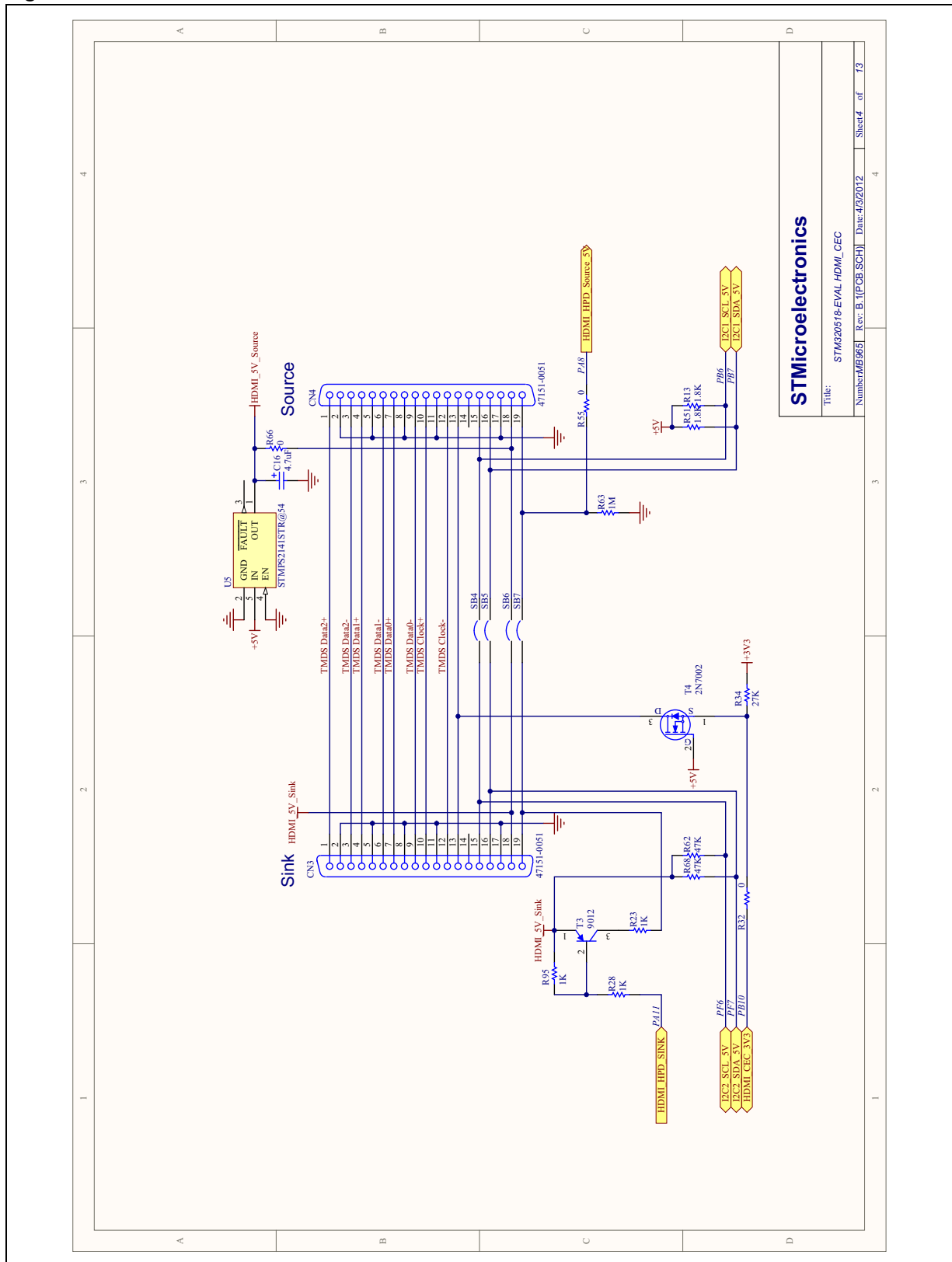
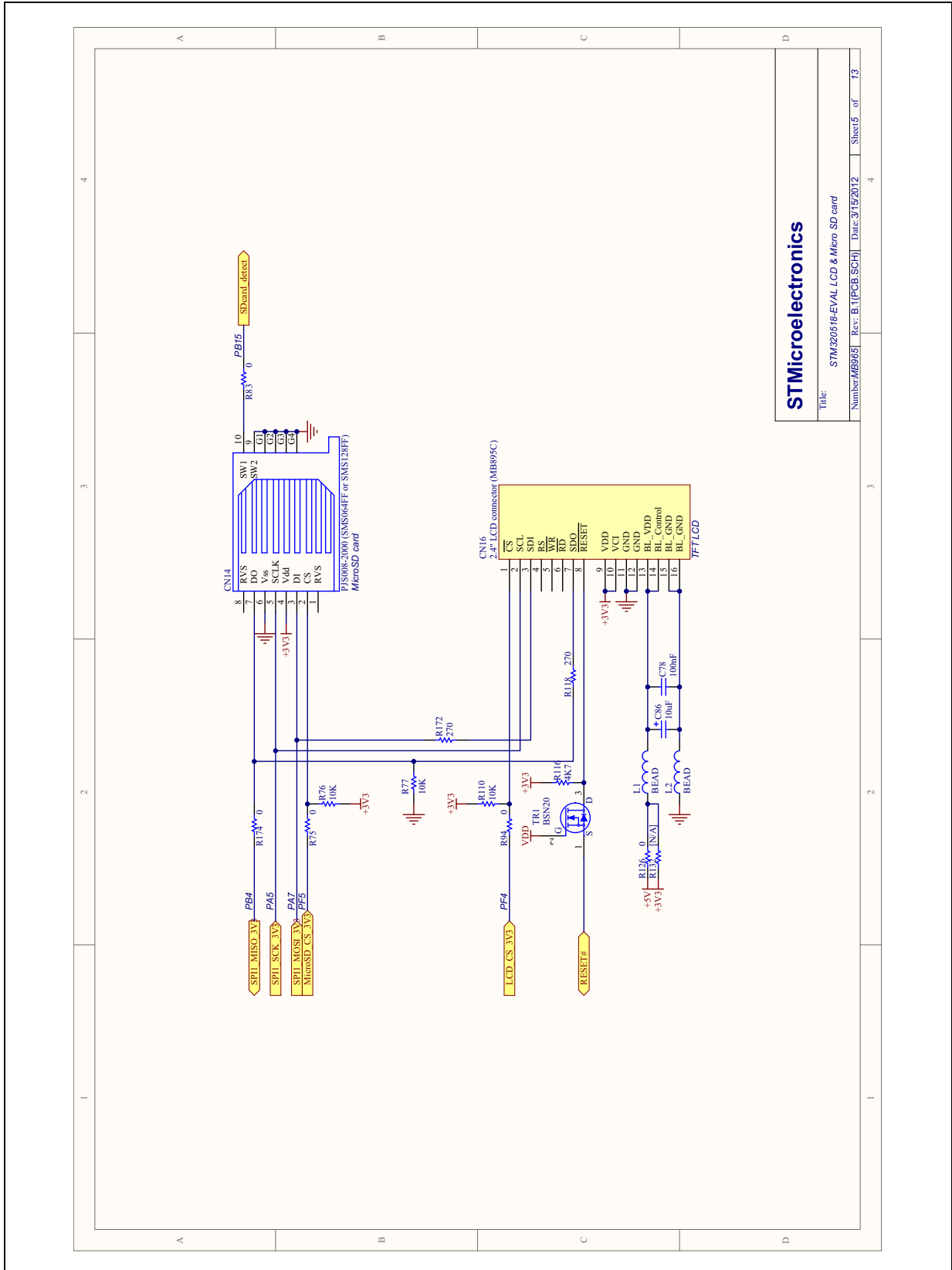

Figure 21. LCD and micro SD card



STMicroelectronics

Title: STM320518 EVAL LCD & Micro SD card
Number/MB965 Rev: B.1(PCB SCH) Date: 3/15/2012 Sheet 5 of 73

Figure 22. Peripherals

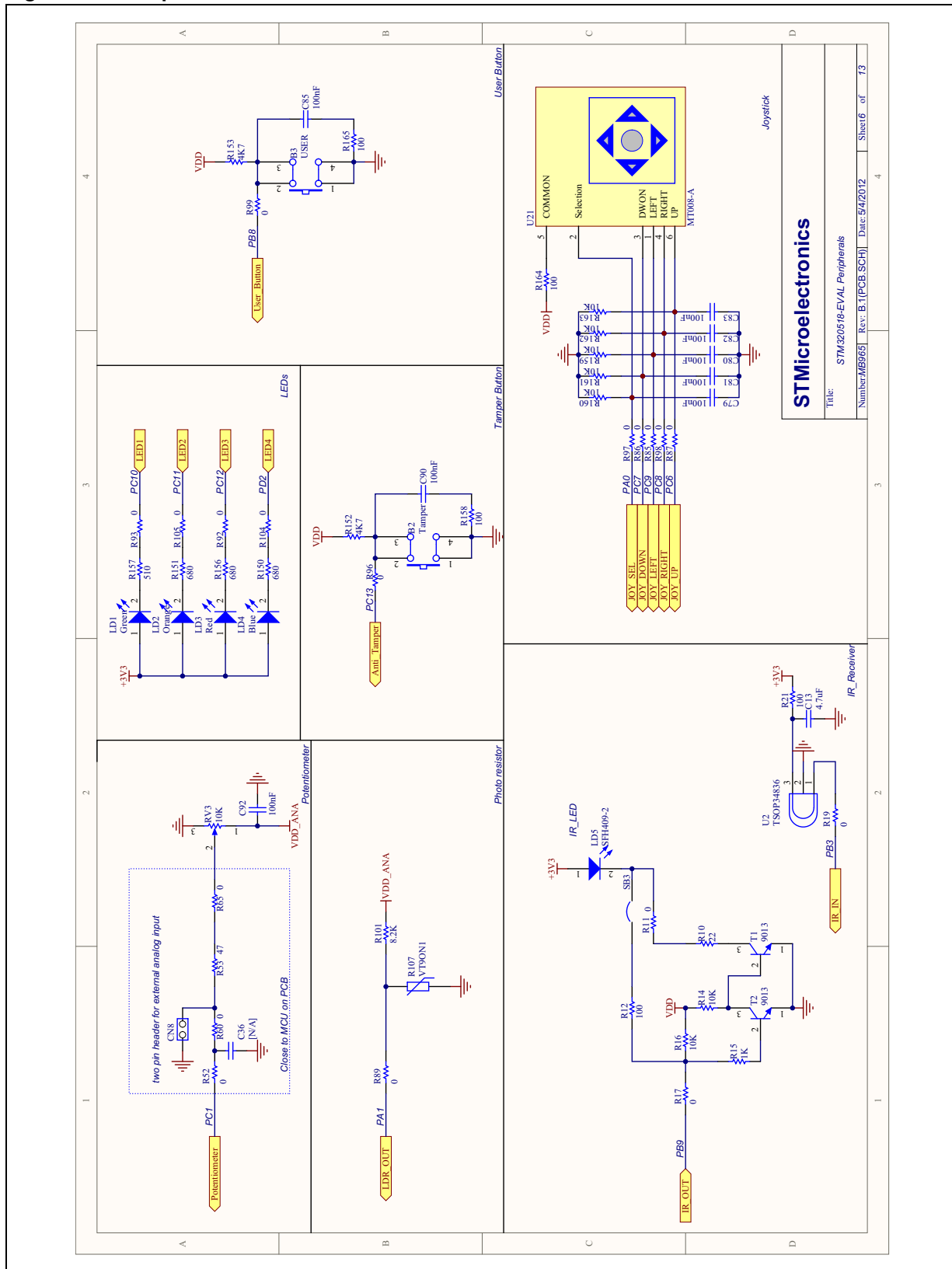

Figure 23. RS-232, RS-485 and IrDA

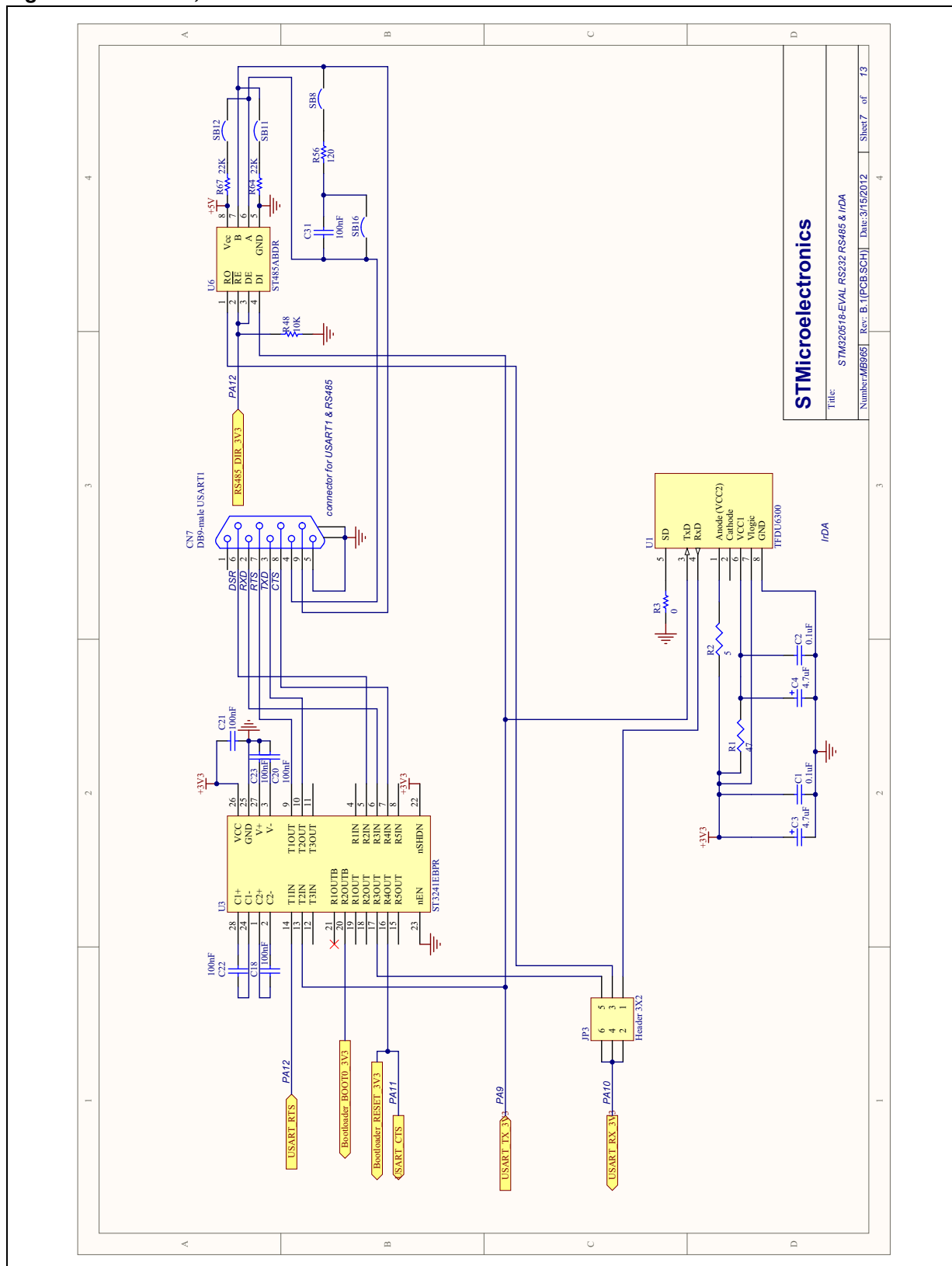

Figure 24. Temperature sensor and RF EEPROM

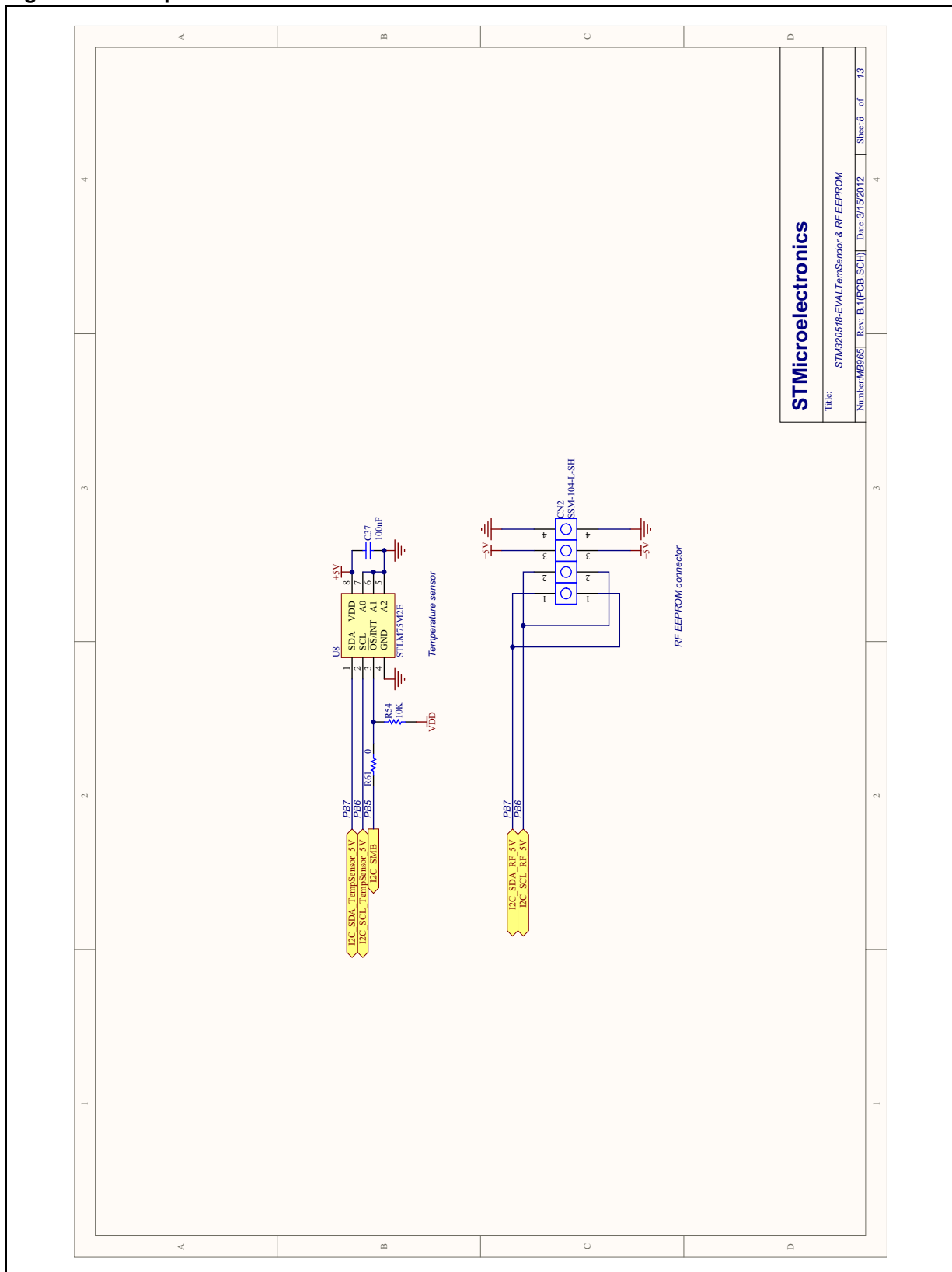

Figure 25. Linear sensor

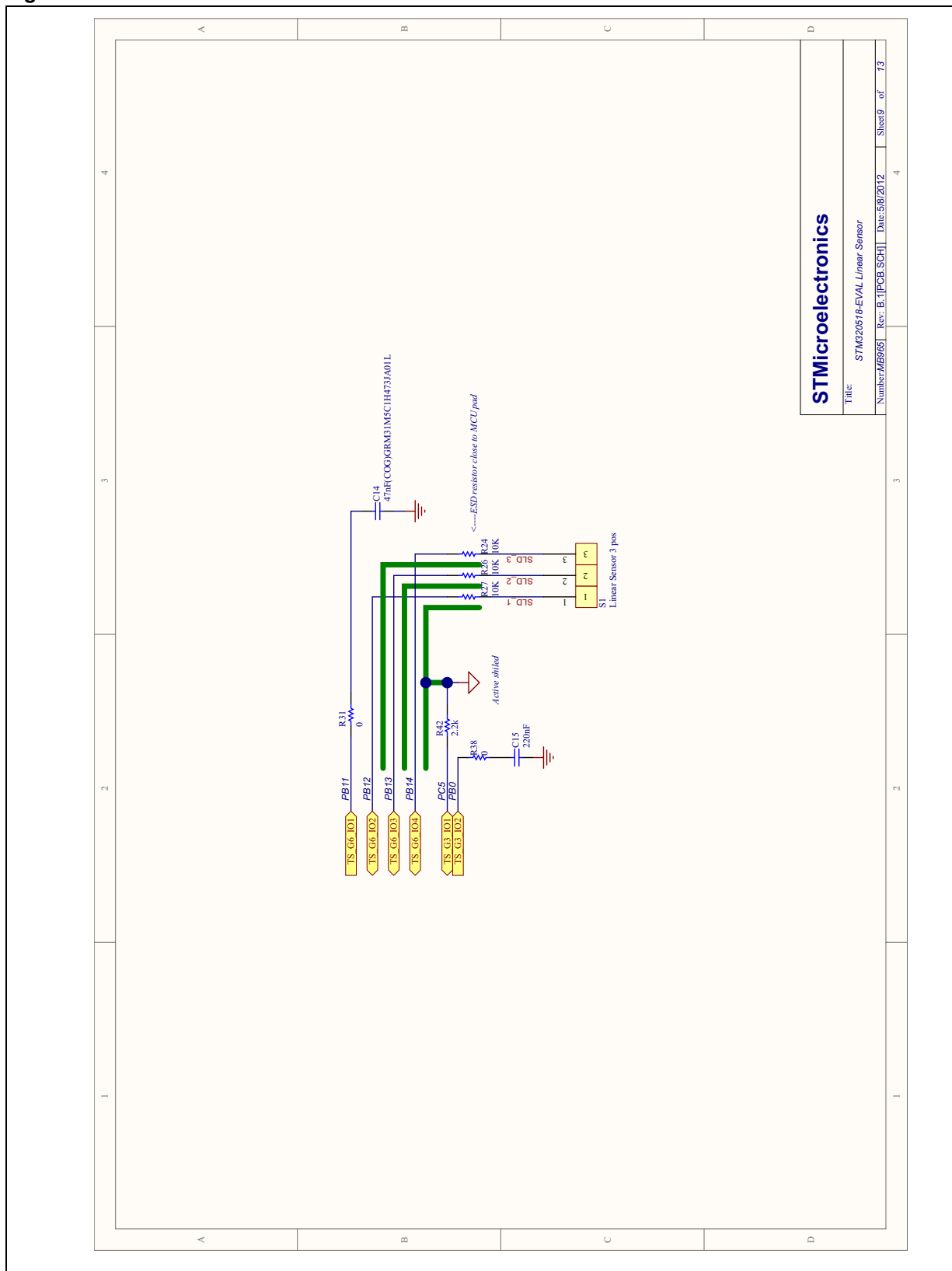

Figure 26. ST-LINK/V2 (SWD only)

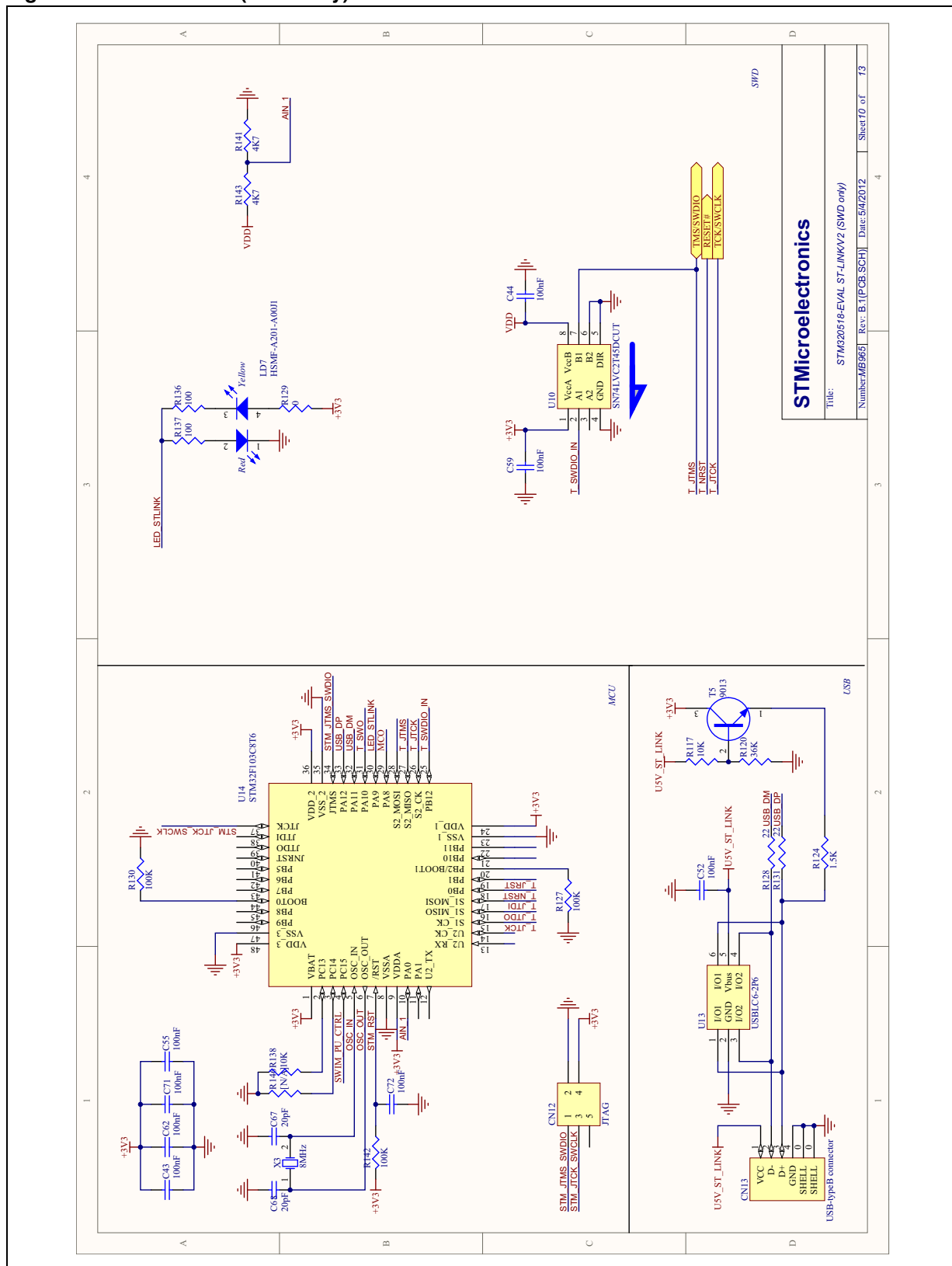
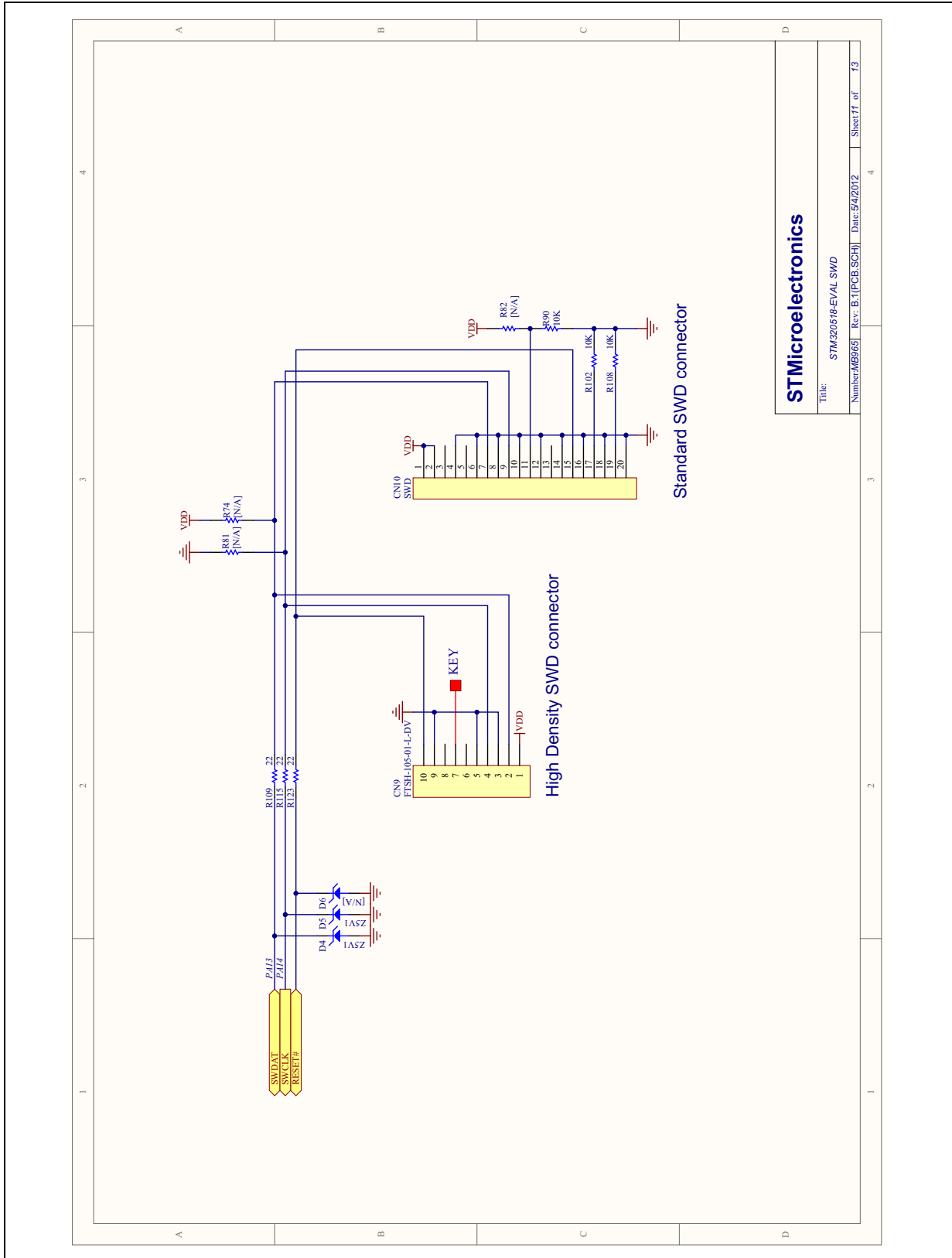
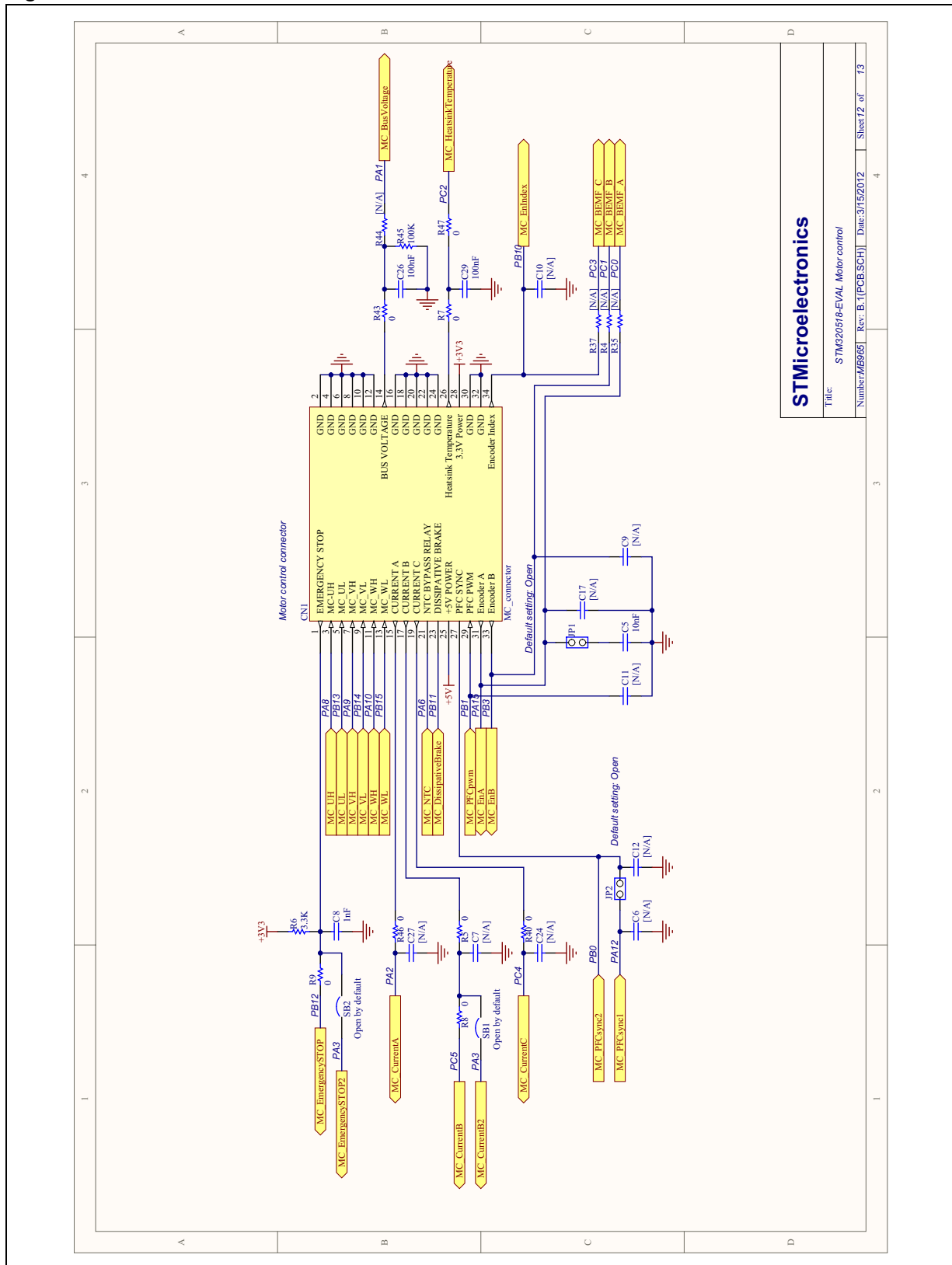

Figure 27. SWD



STMicroelectronics
 Title: STM320516-EVAL SWD
 Number: MB965 Rev. B1[PCB.SCH] Date: 5/4/2012 Sheet 11 of 13

Figure 28. Motor control



STMicroelectronics
 Title: STM320568-EVAL Motor control
 Number:MB965 Rev: B.1[PCB.SCH] Date:3/15/2012 Sheet 12 of 13



Figure 29. Power

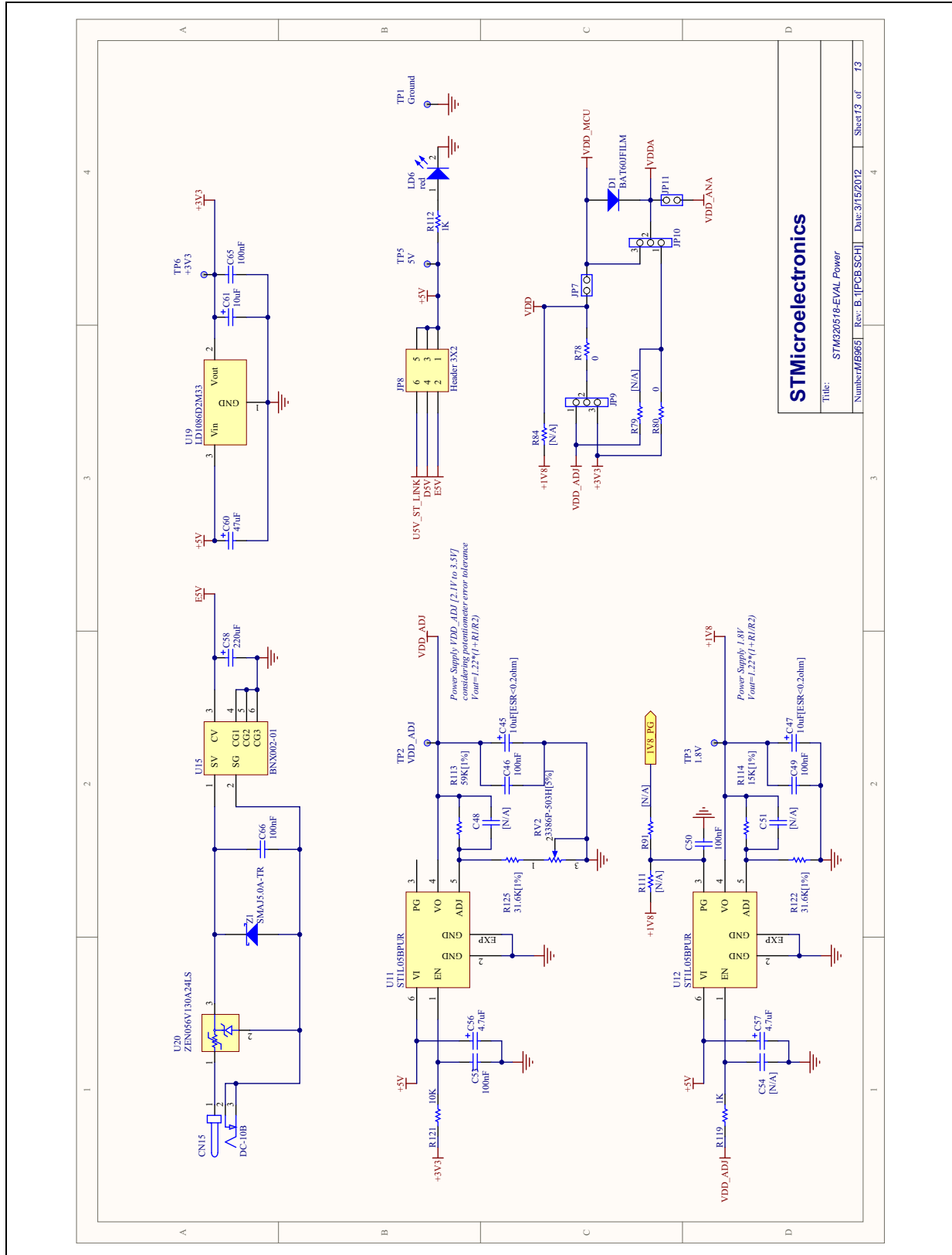
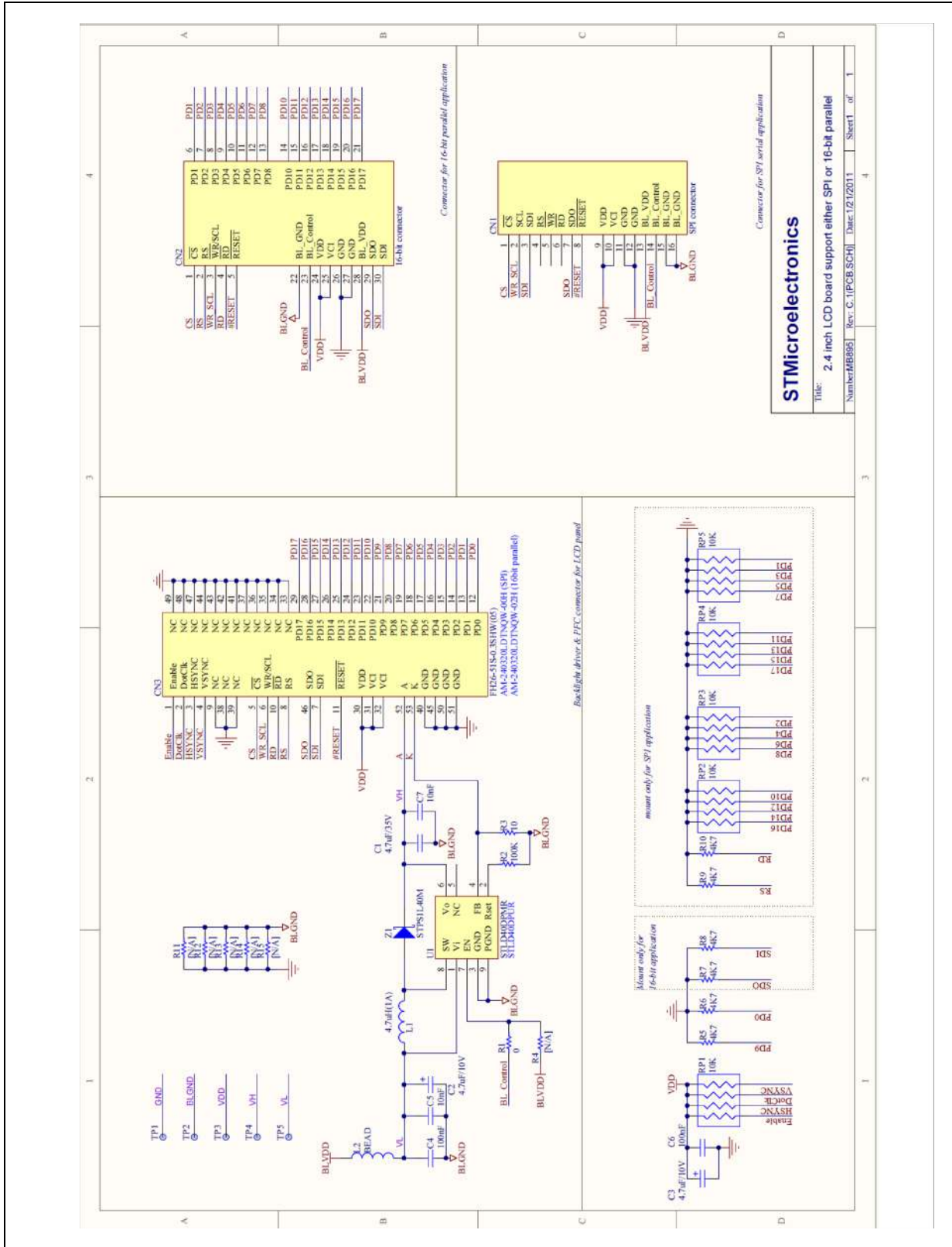

Figure 30. 2.4 inch LCD module



Appendix A STM320518-EVAL I/O assignments

Table 26. STM32F051R8T6 MCU pin assignments

Pin number	Pin name	STM320518-EVAL general I/O assignment	STM320518-EVAL motor control I/O assignment
1	VBAT	VBAT	
2	PC13 - TAMPER1 - WKUP2	TAMPER_KEY	
3	PC14 - OSC32_IN	OSC32_IN	
4	PC15 - OSC32_OUT	OSC32_OUT	
5	PF0 - OSC_IN	OSC_IN	
6	PF1 - OSC_OUT	OSC_OUT	
7	NRST	NRST	
8	PC0	Audio_IN	MC_AIN10 (BEMF_A)
9	PC1	Potentiometer	MC_AIN11 (BEMF_B)
10	PC2		MC_ADC_IN12(headsink temperature)
11	PC3		MC_Ain13 (BEMF_C)
12	VSSA / VREF-	VSSA	
13	VDDA / VREF+	VDDA	
14	PA0 - TAMPER2 - WKUP1	JOY_SEL	
15	PA1	LDR_IN+	MC_AIN1_COMP1_INI+ (bus voltage)
16	PA2		MC_ADC_IN2 (current A)
17	PA3		MC_AIN3_COMP2_IN+ (current B2) / (emergencySTOP2)
18	PF4	LCD_CS	
19	PF5	SD_CS	
20	PA4	Audio_OUT	
21	PA5	LCD/SD_SCK	
22	PA6		MC_IO (NTC_bypass)
23	PA7	LCD/SD_MOSI	
24	PC4		MC_AIN14 (current C)
25	PC5	TS_Shield	MC_AIN15 (current B)
26	PB0	TS_Shield_CAP	MC_TIM3_CH3 (PFC_sync2)

Table 26. STM32F051R8T6 MCU pin assignments (continued)

Pin number	Pin name	STM320518-EVAL general I/O assignment	STM320518-EVAL motor control I/O assignment
27	PB1		MC_TIM3_CH4 (PFC PWM)
28	PB2 or NPOR (1.8V mode)	1.8 V POR	
29	PB10	HDMI_CEC	MC_TIM2_CH3 (encoder index)
30	PB11	TS_CAP	MC_IO (dissipative brake)
31	VSS_2	VSS	
32	VDD_2	VDD	
33	PB12	TS_CH1	MC_TIM1_BKIN (emergency STOP)
34	PB13	TS_CH2	MC_TIM1_CH1N(UL)
35	PB14	TS_CH3	MC_TIM1_CH2N (VL)
36	PB15	SD_Detection	MC_TIM1_CH3N (WL)
37	PC6	JOY_UP	
38	PC7	JOY_DOWN	
39	PC8	JOY_RIGHT	
40	PC9	JOY_LEFT	
41	PA8	HDMI_HPD_Source	MC_TIM1_CH1 (UH)
42	PA9	RS232/RS485/irDA_TX	MC TIM1_CH2 (VH)
43	PA10	RS232/RS485/irDA_RX	MC_TIM1_CH3 (WH)
44	PA11	HDMI_HPD_Sink / RS232_CTS	
45	PA12	RS485_DIR / RS232_RTS	MC_IO (PFC_sync1)
46	PA13	SWDAT	
47	PF6	I2C2_SCL_HDMI_Sink	
48	PF7	I2C2_SDA_HDMI_Sink	
49	PA14	SWCLK	
50	PA15		MC_TIM2_CH1 (encoder A)
51	PC10	LED1	
52	PC11	LED2	
53	PC12	LED3	
54	PD2	LED4	
55	PB3	IR_IN	MC_TIM2_CH2 (encoder B)
56	PB4	LCD/SD_MISO	
57	PB5	TempSensor_INT	

Table 26. STM32F051R8T6 MCU pin assignments (continued)

Pin number	Pin name	STM320518-EVAL general I/O assignment	STM320518-EVAL motor control I/O assignment
58	PB6	TempSensor/HDMI/RF_SCL / MC_USART1_TX	
59	PB7	TempSensor/HDMI/RF_SDA / MC_USART1_RX	
60	BOOT0	BOOT0	
61	PB8	User_KEY	
62	PB9	IR_OUT	
63	VSS_1	VSS	
64	VDD_1	VDD	

Appendix B Mechanical dimensions

Figure 31. Mechanical dimensions

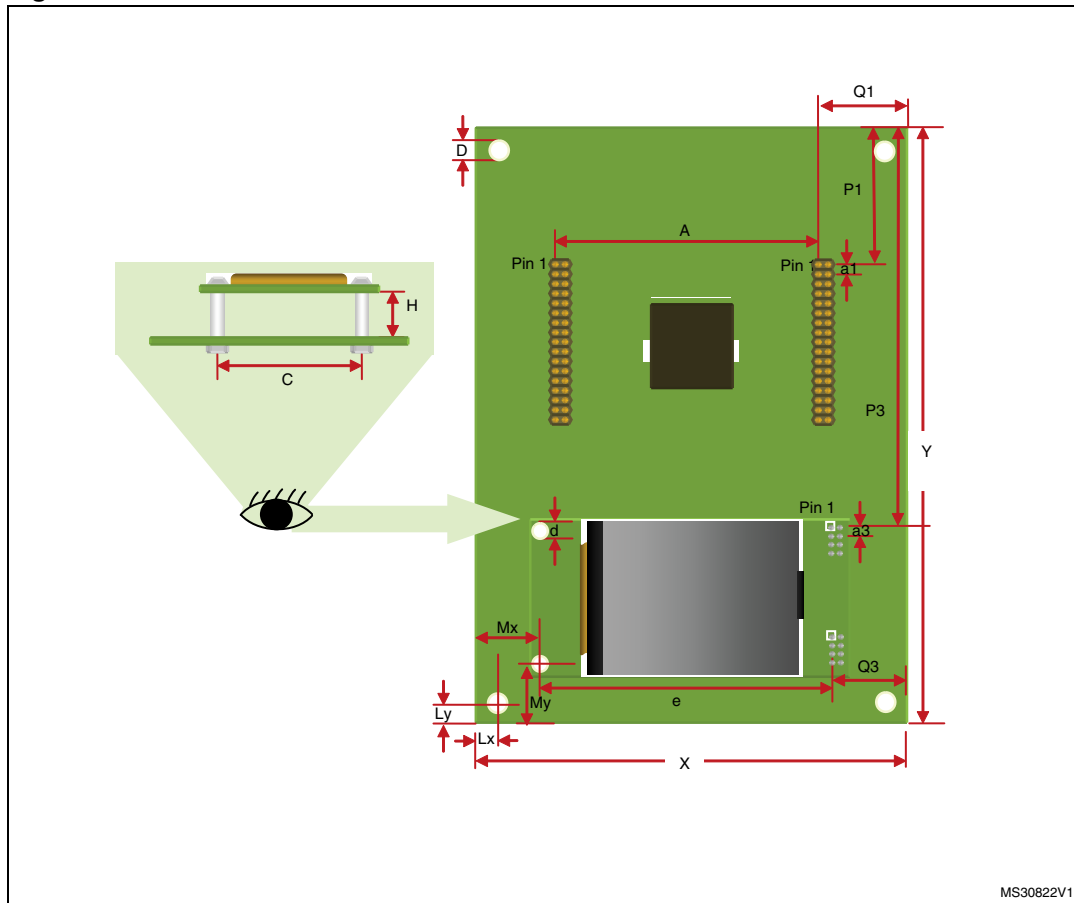

MS30822V1

Table 27. Mechanical dimensions

Symbol	Dimensions (mm)	Symbol	Dimensions (mm)	Symbol	Dimensions (mm)
A	68.58	e	77.443	P1	40.64
a1	2.54	H	11	P3	115.247
a3	2.54	Lx	5.715	Q1	25.4
C	36	Ly	5.715	Q3	19.837
D	3.5	Mx	17.02	X	114.3
d	3.2	My	20.32	Y	172.72

Revision history

Table 28. Document revision history

Date	Revision	Changes
21-May-2012	1	Initial release.

Please Read Carefully:

Information in this document is provided solely in connection with ST products. STMicroelectronics NV and its subsidiaries ("ST") reserve the right to make changes, corrections, modifications or improvements, to this document, and the products and services described herein at any time, without notice.

All ST products are sold pursuant to ST's terms and conditions of sale.

Purchasers are solely responsible for the choice, selection and use of the ST products and services described herein, and ST assumes no liability whatsoever relating to the choice, selection or use of the ST products and services described herein.

No license, express or implied, by estoppel or otherwise, to any intellectual property rights is granted under this document. If any part of this document refers to any third party products or services it shall not be deemed a license grant by ST for the use of such third party products or services, or any intellectual property contained therein or considered as a warranty covering the use in any manner whatsoever of such third party products or services or any intellectual property contained therein.

UNLESS OTHERWISE SET FORTH IN ST'S TERMS AND CONDITIONS OF SALE ST DISCLAIMS ANY EXPRESS OR IMPLIED WARRANTY WITH RESPECT TO THE USE AND/OR SALE OF ST PRODUCTS INCLUDING WITHOUT LIMITATION IMPLIED WARRANTIES OF MERCHANTABILITY, FITNESS FOR A PARTICULAR PURPOSE (AND THEIR EQUIVALENTS UNDER THE LAWS OF ANY JURISDICTION), OR INFRINGEMENT OF ANY PATENT, COPYRIGHT OR OTHER INTELLECTUAL PROPERTY RIGHT.

UNLESS EXPRESSLY APPROVED IN WRITING BY TWO AUTHORIZED ST REPRESENTATIVES, ST PRODUCTS ARE NOT RECOMMENDED, AUTHORIZED OR WARRANTED FOR USE IN MILITARY, AIR CRAFT, SPACE, LIFE SAVING, OR LIFE SUSTAINING APPLICATIONS, NOR IN PRODUCTS OR SYSTEMS WHERE FAILURE OR MALFUNCTION MAY RESULT IN PERSONAL INJURY, DEATH, OR SEVERE PROPERTY OR ENVIRONMENTAL DAMAGE. ST PRODUCTS WHICH ARE NOT SPECIFIED AS "AUTOMOTIVE GRADE" MAY ONLY BE USED IN AUTOMOTIVE APPLICATIONS AT USER'S OWN RISK.

Resale of ST products with provisions different from the statements and/or technical features set forth in this document shall immediately void any warranty granted by ST for the ST product or service described herein and shall not create or extend in any manner whatsoever, any liability of ST.

ST and the ST logo are trademarks or registered trademarks of ST in various countries.

Information in this document supersedes and replaces all information previously supplied.

The ST logo is a registered trademark of STMicroelectronics. All other names are the property of their respective owners.

© 2012 STMicroelectronics - All rights reserved

STMicroelectronics group of companies

Australia - Belgium - Brazil - Canada - China - Czech Republic - Finland - France - Germany - Hong Kong - India - Israel - Italy - Japan - Malaysia - Malta - Morocco - Philippines - Singapore - Spain - Sweden - Switzerland - United Kingdom - United States of America

www.st.com