

MATERIALS AND FINISHES

BODY, CRIMP TUBE, C'NUT, CAP: BRASS  
PLATED NICKEL

CONTACT: BRASS  
PLATED GOLD

INSULATOR: TEFLON

GASKET: SILICONE RUBBER

SNAP RING: BERYLLIUM COPPER

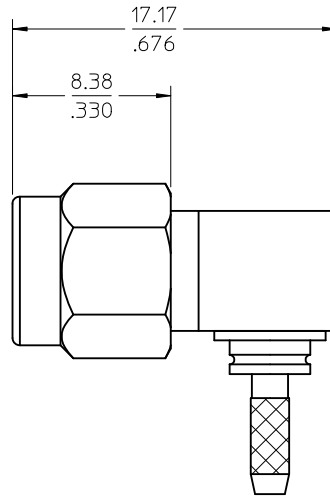
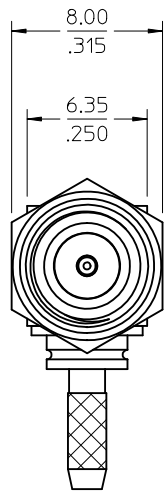
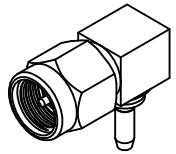

DOME CAP

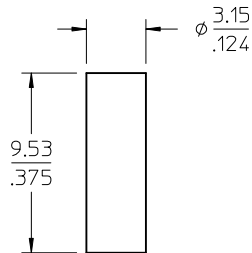
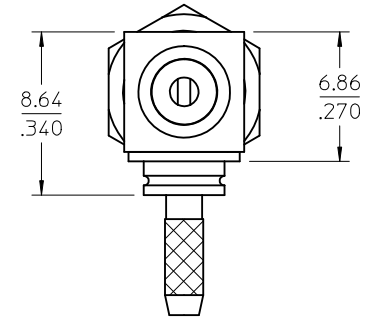

CRIMP TUBE

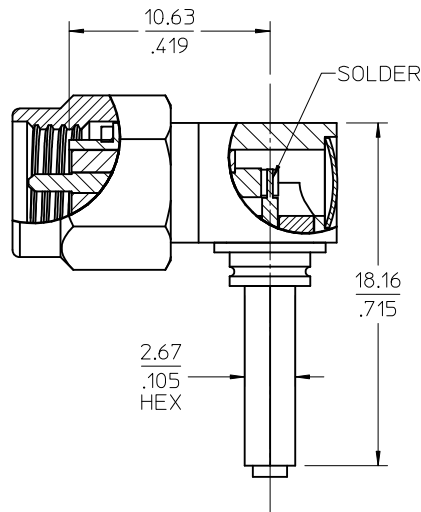

SOLDER

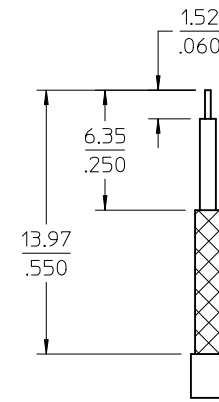

RG178

PART # 73251-0750

MIL-STD-348A, FIG. 310.1	INTERFACE
SPECIFICATION	DESCRIPTION

CHG: RELEASE DRAWING.	EC NO: URF2012-0507	QUALITY SYMBOLS	GENERAL TOLERANCES (UNLESS SPECIFIED)	DIMENSION STYLE	SCALE	DESIGN UNITS	THIRD ANGLE PROJECTION
DRWN: AROBERTSON 2012/01/27	CHKD: SSS 2012/01/27	▽=0	4 PLACES ± --- ± ---	MM/IN	INCH	INCH	☉
APPR: JWIENER 2012/02/24		▽=0	3 PLACES ± --- ± ---				
			2 PLACES ± --- ± ---				
			1 PLACE ± --- ± ---				
			ANGULAR ± 2 °				
			DRAFT WHERE APPLICABLE MUST REMAIN WITHIN DIMENSIONS				

DRAWN BY: AROBERTSON 2012/01/27		DATE: 2012/01/27		TITLE: SMA PLUG RA BRASS FOR RG178 SMA-PC/RA	
CHECKED BY: SSS		DATE: 2012/01/27		MOLEX INCORPORATED	
APPROVED BY: JWIENER		DATE: 2012/02/24			
MATERIAL NO. 732510750		DOCUMENT NO. SD-73251-075		SHEET NO. 1 OF 1	
THIS DRAWING CONTAINS INFORMATION THAT IS PROPRIETARY TO MOLEX INCORPORATED AND SHOULD NOT BE USED WITHOUT WRITTEN PERMISSION					