



# High Frequency, High Current Power Inductors



- Significantly high Q factor – twice as high as 2014VS
- High current handling
- Ideal for use as a low-loss choke on RF power amplifiers

**Environmental** RoHS compliant, halogen free

**Terminations** RoHS compliant tin-silver over copper

**Weight** 1.99 – 2.74 g

**Ambient temperature** –40°C~125°C with Irms current

**Maximum part temperature** +155°C (ambient + temp rise).

**Storage temperature** Component: –40°C to +155°C.

Tape and reel packaging: –40°C to +80°C

**Resistance to soldering heat** Max three 40 second reflows at +260°C, parts cooled to room temperature between cycles

**Temperature Coefficient of Inductance (TCL)** +5 to +70 ppm/°C

**Moisture Sensitivity Level (MSL)** 1 (unlimited floor life at <30°C / 85% relative humidity)

**Packaging ZA9423-33N** 500/13"reel; Plastic tape: 32 mm wide, 0.50 mm thick, 20 mm pocket spacing, 6.4 mm pocket depth;

**ZA9423-66N** 450/13"reel; Plastic tape: 32 mm wide, 0.50 mm thick, 20 mm pocket spacing, 6.8 mm pocket depth

**PCB washing** Tested to MIL-STD-202 Method 215 plus an additional aqueous wash. See [Doc787\\_PCB\\_Washing.pdf](#).

Part number <sup>1</sup>	Inductance <sup>2</sup> ±20% (nH)	Q <sup>3</sup> typ	Q test freq (MHz)	SRF typ <sup>4</sup> (MHz)	DCR (mOhm)		Irms (A) <sup>5</sup>	
					typ	max	20°C rise	40°C rise
ZA9423-33NMED	33	456	100	817	0.53	0.62	30.2	42.0
ZA9423-66NMED	66	404	100	436	0.75	0.90	27.0	38.5

- Packaging:** D = 13" machine-ready reel; EIA-481 embossed plastic tape (ZA9423-33N, 500 parts per full reel; ZA9423-66N, 450 parts per full reel). Quantities less than full reel available: in tape (not machine ready) or with leader and trailer (\$25 charge).
- Inductance measured at 1.0 MHz, 0.1 Vrms, 0 A using an Agilent/HP HP4291A impedance analyzer with an Agilent/HP 16193A test fixture or equivalents.
- Q measured at the specified frequency using an Agilent/HP 4291A impedance analyzer or equivalent.

- SRF measured using an Agilent/HP 8753 network analyzer or equivalent and a Coilcraft CCF1199 test fixture
- Current that causes the specified temperature rise from 25°C ambient. This information is for reference only and does not represent absolute maximum ratings.
- Electrical specifications at 25°C. Refer to Doc 362 "Soldering Surface Mount Components" before soldering.



# High Frequency, High Current Power Inductors – ZA9423

## L vs Frequency

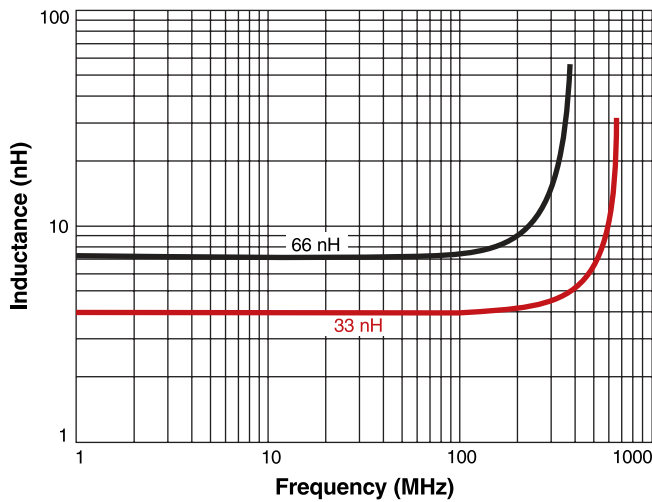

## Q vs Frequency

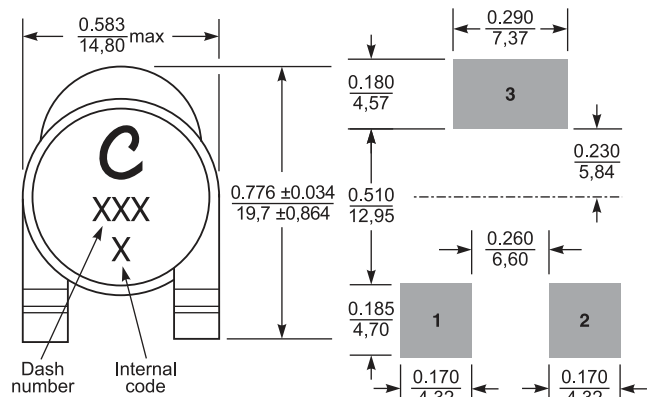
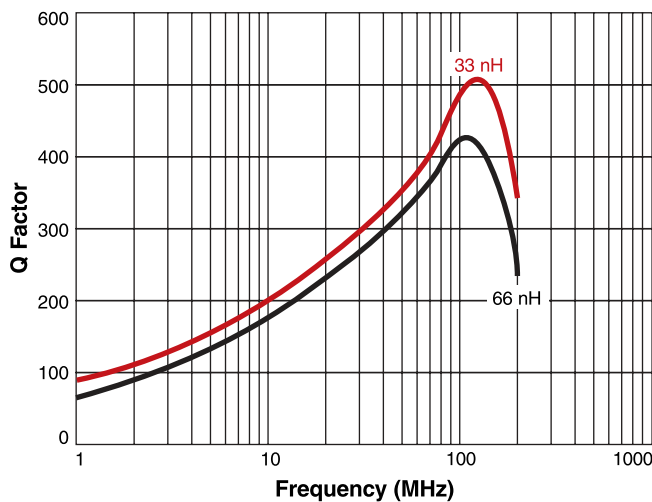

Part number	Height (max)		Weight (g)
	inches	mm	
ZA9423-33N	0.250	6,35	1.99
ZA9423-66N	0.279	7,09	2.74

## Recommended Land Pattern

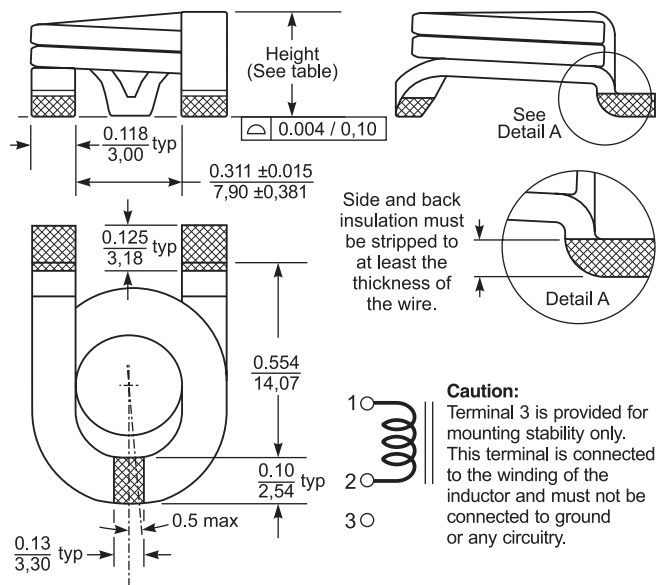

**Caution:**  
Terminal 3 is provided for mounting stability only. This terminal is connected to the winding of the inductor and must not be connected to ground or any circuitry.

All dimensions are in inches/mm.



**US** +1-847-639-6400 sales@coilcraft.com  
**UK** +44-1236-730595 sales@coilcraft-europe.com  
**Taiwan** +886-2-2264 3646 sales@coilcraft.com.tw  
**China** +86-21-6218 8074 sales@coilcraft.com.cn  
**Singapore** + 65-6484 8412 sales@coilcraft.com.sg

Document 1682-2 Revised 06/09/21  
 © Coilcraft Inc. 2023  
 This product may not be used in medical or high risk applications without prior Coilcraft approval. Specification subject to change without notice. Please check web site for latest information.