

Dual IGBT Isolated Driver (Non Inverting)

$$V_{Cmax} = 1200V$$

$$I_{OUTpeak} = 8A @ T_c = 25^{\circ}C$$

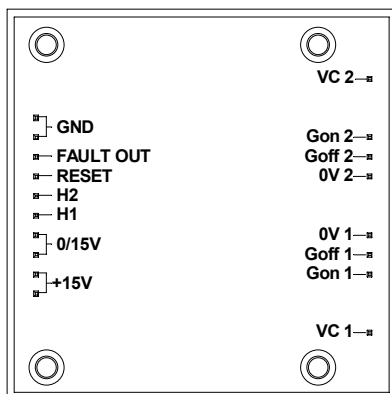
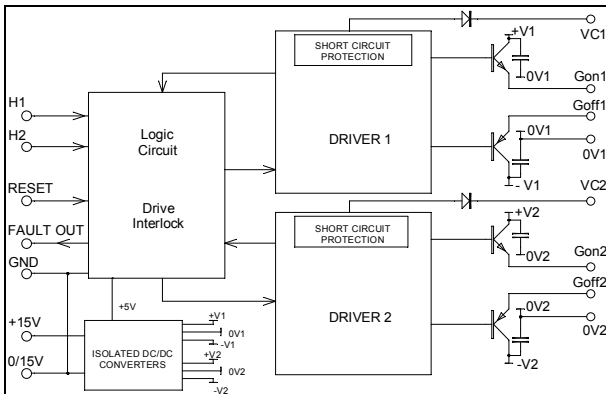

Application

- Driver dedicated to IGBT Power modules in :
 - Motor Control
 - Uninterruptible Power Supplies
 - Switched Mode Power Supplies
 - Welding converters
 - Automotive

Features

- Drive IGBTs up to $I_C=300A$, $V_{CE}=1200V$
- Short circuit protection by V_{CEsat} monitoring
- Low speed overcurrent cut off to limit over voltage
- Under voltage Lockout with hysteresis
- Top Bottom input signals Interlock
- Switching frequency up to 50 kHz
- Low stray inductance
- High level of integration
- Isolated driver

Benefits

- Outstanding performance at high frequency operation
- Rugged
- Stable temperature behavior
- Very high noise immunity (common mode rejection $> 10kV/\mu s$)
- 2500V Galvanic Isolation primary/secondary
- 5V logic level with Schmitt-trigger Input
- Single $V_{DD}=15V$ supply required
- Positive & Negative Secondary auxiliary power supplies internally generated
- Separate sink & Source output for easy Gate drive (optimized turn on & turn off operation)
- Mounting with screws for good vibration withstand
- Solderable pins
- RoHS Compliant

CAUTION: These Devices are sensitive to Electrostatic Discharge. Proper Handling Procedures Should Be Followed.

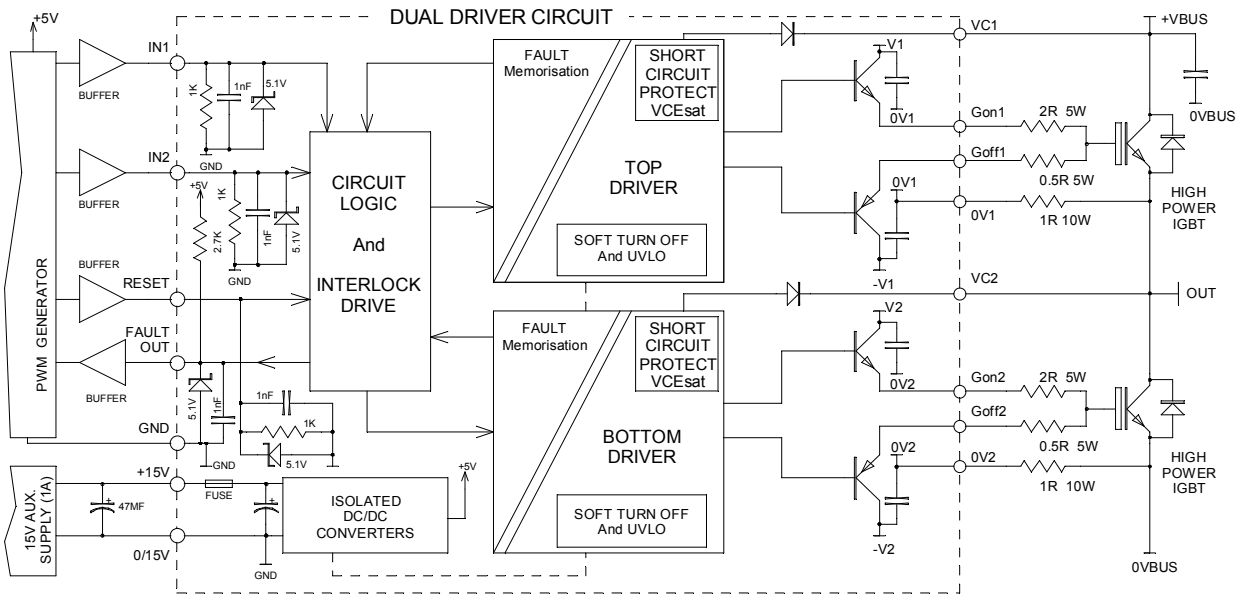

fig 1: Typical phase leg Operation Block Diagram

All ratings @ $T_j = 25^\circ\text{C}$ unless otherwise specified

Absolute maximum ratings

Symbol	Parameter	Max ratings	Unit
V_{DD}	Supply Voltage	16	V
V_{Hi}	Input signal voltage $i=1, 2$	5.5	V
I_{VDDmax}	Maximum Supply current	$V_{Hi} = 0V, i = 1, 2$	0.3
		$V_{DD} = 15V, F_{out} = 25 \text{ kHz}, C_{eff} = 150nF$	1
f_{max}	Maximum Switching Frequency @ $T_{amb} = 85^\circ\text{C}$	50	kHz
V_C	Collector Voltage short circuit protection pin	1200	V
$I_{outAVmax}$	Output Average Current	Per Output	270
R_{Gonmin}	Minimum resistance for R_{Gon}	2	Ω
$R_{Goffmin}$	Minimum resistance for R_{Goff}	1	Ω
P_{out}	Output Power DC/DC converter	Per Output	4
$I_{out peak}$	Sink and Source	8	A

Driver Electrical Characteristics

<i>Symbol</i>	<i>Characteristic</i>	<i>Test Conditions</i>	<i>Min</i>	<i>Typ</i>	<i>Max</i>	<i>Unit</i>	
V _{DD}	Operating Supply Voltage		14.5	15	15.5	V	
I _{VDD}	Operating Supply Current	F _{out} =25kHz, V _{DD} =15V, V _{Bus} =600V C _{eff} =150nF on Channel 1&2		0.75		A	
V _{UVLO}	Under Voltage lockout threshold		11.6	12.3	13.5	V	
V _{Hi(max)}	Maximum Input Voltage	i = 1, 2	-0.5	5	5.5	V	
V _{Hi(th+)}	Positive Going Threshold Voltage		2				
V _{Hi(th-)}	Negative Going Threshold Voltage				0.8		
C _{Hi}	Input Capacitance *			1			nF
R _{Hi}	Input Resistance *			1			kΩ
V _{G(on)}	Turn on Gate Voltage Output	No Load R _{Gon} =2Ω, F _{out} = 25kHz, C _{eff} =150nF	14	15	16	V	
V _{G(off)}	Turn off Gate Voltage Output	No Load R _{Goff} =1Ω, F _{out} = 25kHz, C _{eff} =150nF	-7	-6	-5		
T _{d(on)}	Turn On delay time	C _{eff} = 150nF ①	200	400	500	ns	
T _{d(off)}	Turn Off delay time	C _{eff} = 150nF ①	220	420	520		
PWD	Pulse Width Distortion		-0.3	0.02	0.3	μs	
PDD	Propagation Delay Difference between any two driver	T _{d(on)} - T _{d(off)}	-0.35		0.35		
I _{fault}	Output fault current	Fault condition			7	mA	
V _{faultH}	High Output Fault Voltage	No fault		5			
V _{faultL}	Low Output Fault Voltage	Fault condition			0.5	V	
T _{dfault}	Desat Fault Output Delay Time	V _{DD} =15V			5		
T _{SC}	Total Short Circuit Duration				6	μs	
I _{SC}	Short Circuit Current	T _{sc} =6μs, V _{Bus} =600V, V _{GE} =15V		950		A	
C _{PS}	Coupling Capacitance Primary Secondary			20		pF	
R _{PW}	Reset Pulse Width	Logic high for reset	20			μs	
R _R	Reset Input Resistance			1		kΩ	
F _R	Fault output pull-up resistance			2.7			

* Low impedance guarantees good noise immunity.

① Dead time between top and bottom inputs signals must be generated externally in case of phase leg operation

Thermal and package characteristics

<i>Symbol</i>	<i>Characteristic</i>		<i>Min</i>	<i>Typ</i>	<i>Max</i>	<i>Unit</i>
V _{ISOL}	Primary to Secondary Isolation		2500			V
T _{OP}	Operating Ambient Temperature		-40		85	°C
T _{STG}	Storage Temperature Range		-55		100	
Torque	Mounting torque	M3		0.5		N.m
Wt	Package Weight				120	g

Driver Package outline

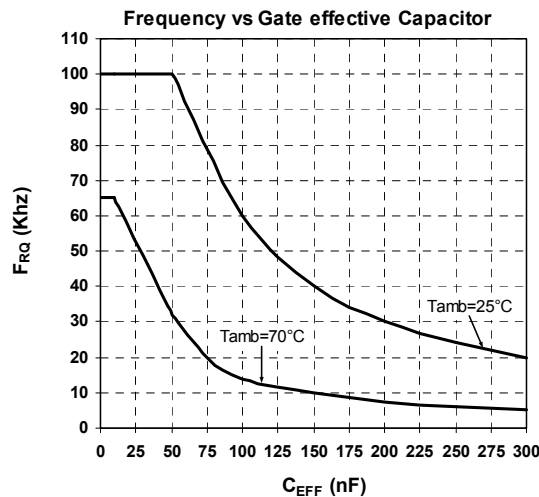
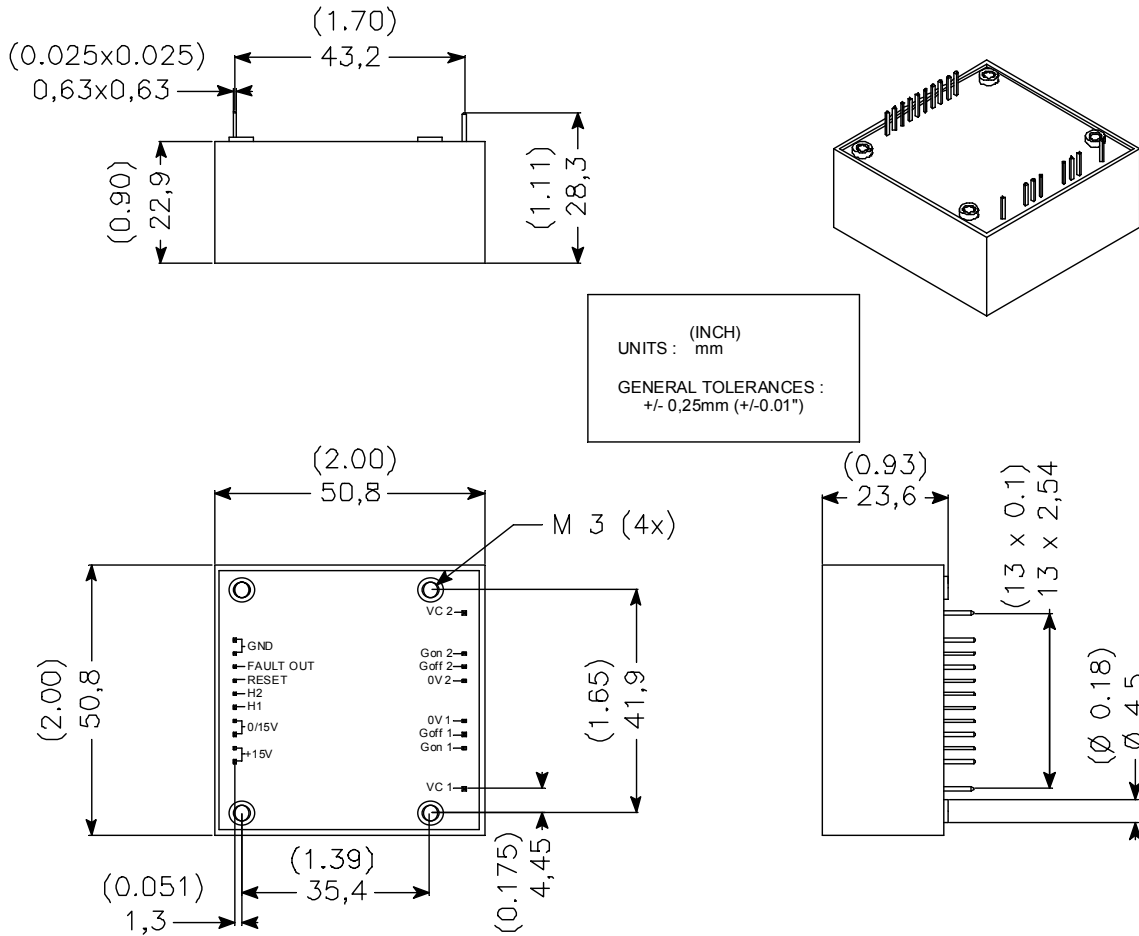

Microsemi reserves the right to change, without notice, the specifications and information contained herein

Microsemi's products are covered by one or more of U.S. patents 4,895,810 5,045,903 5,089,434 5,182,234 5,019,522 5,262,336 6,503,786 5,256,583 4,748,103 5,283,202 5,231,474 5,434,095 5,528,058 and foreign patents. U.S. and Foreign patents pending. All Rights Reserved.